



Operator's Manual

(SN25001-25999)

Model JH7110 & JH9110

Hillside Leveling System

For John Deere S7 600, S7 700, S7 800, & S7 900

	 WARNING
	<p>Read and understand operator's manual prior to operating this equipment.</p> <p>Failure to follow operation instructions could result in personal injury or damage to the equipment.</p>

Contents

Model and Serial Number	1
Maximum Header Weights	1
Introduction.....	2
Safety	3
Signal Words	3
Operation Safety.....	4
Hydraulic Safety.....	4
Service and Maintenance Safety.....	5
Highway Operation and Transport Safety.....	5
Safety Labels	6
Product Description	10
Controls and Components.....	11
Leveling Control Switches & Monitor.....	11
Hydraulic Gear Pump	12
JH9110 Hydraulic Flow	12
Leveling Control Manifold	12
Leveling Controller.....	13
Header Tilt Manifold.....	13
Overcarriage Position Indicator	14
Slope Sensing Clinometer	14
Rear Wheel Assist Clinometer	14
Transition	14
Header Position Sensor.....	15
Mechanical Leveling Cylinder Stops.....	16
Carriage.....	16
Hydraulic Leveling Cylinders and Counter-Balance Valves.....	16
Leveling Cylinder Safety Stops.....	17
Drop Axle	17
Header Tilt Control Switches	18
Header Tilt System	18
Header Tilt Controls and Components.....	18
Operation, Setup, and Maintenance.....	19
Leveling System Controls.....	20
Maximum Level.....	21
Header Trim Controls.....	21
Rear Wheel Assist Warning Alarm	22
Operator Adjustments.....	23
Manual Speed.....	24
Display Backlight	24
Smart Unload.....	25
Calibration	25
Joystick Calibration.....	26
Left/Right Clinometer Calibration (Level Zero Point)	28
Carriage Angle Left Limit	29
Carriage Angle Right Limit.....	30
Fore/Aft Clinometer.....	31
Carriage Sensor.....	32
Left PWM Calibration.....	33
Right PWM Calibration	34

Diagnostics	35
Clinometers.....	35
Carriage Sensor.....	36
Valve Coils	36
Joystick.....	36
Combine CAN.....	37
Active Alarms.....	37
Dealer Settings.....	39
Storage.....	40
Transporting Combine on a Trailer	40
Maintenance.....	41
Hydraulic Filter.....	44
Driveline Maintenance	44
Transition Drive Chain	45
Transition Slip Clutch.....	45
Paddle Beater	45
Feeder House Removal.....	45
100 Hour - Annual Maintenance	46
Critical Joint Inspection.....	47
Adjustments	49
Rear Axle Spacing	49
Rear Axle Position Chart.....	49
Over Rotation Stop	50
Transition Fore/Aft Adjustment Procedure.....	50
Lower Feeder Drum Stop Adjustment.....	50
Lateral Tilt Flow Control Adjustment	51
Mechanical Leveling Cylinder Stops.....	52
Header Tilt Setup.....	53
Tread Width	55
Tire Selection.....	55
Feeder Adjustment For Tire Size	55
Tire Inflation.....	55
Rear Axle Toe In	56
General Shielding	56
Drive Shaft and Couplers	56
Rear Axle Weighting	56
Hydraulic Settings.....	57
Hydraulic Hoses	57
Hydraulic Cylinder	57
Header Compatibility Chart	58
Leveling System Specifications	59
Electrical Schematics	61
Hydraulic Schematics	67
Notes	74



Statement of Limited Warranty

Class I Warranty

Attached / Integrated Equipment, Parts, & Labor

Hillco warrants its Class I products to be free from defects in material and workmanship for a period of twelve (12) consecutive months following the warranty start date.

The warranty start date for Hillco products invoiced by Hillco from October 1st through May 31st is the first day of June following the Hillco invoice date, or the first date of use, whichever is earliest. For Hillco products invoiced by Hillco from June 1st through September 30th the warranty start date is the date of invoice. Once the warranty period has begun, it cannot be stopped or interrupted.

Hillco warrants genuine Hillco replacement parts and components to be free from defects in material and workmanship for a period of ninety (90) consecutive days following the Hillco invoice date, or the remainder of the original equipment warranty period, whichever is longer.

Hillco's obligation under this product and parts warranty shall be limited to repairing or replacing, free of charge to the original purchaser, any part(s) that, in Hillco's judgment, shows evidence of such defect. Hillco additionally agrees to repair any physical damage to the product to which the Hillco product is directly attached provided that the damage is directly attributable to a defect in the design or manufacture of the Hillco product, as determined by Hillco, and that the damage occurs during the effective warranty period of the Hillco product.

Limitations to Warranty

This warranty does not cover:

- 1) Any product damaged by accident, abuse, misuse, negligence, or improper maintenance.
- 2) Any unauthorized product alteration or modification.
- 3) Any unauthorized repairs made with parts other than genuine Hillco parts unless specifically authorized by Hillco.
- 4) Any repairs performed by anyone other than Hillco or an authorized Hillco dealer unless specifically authorized by Hillco.
- 5) Any claims directly resulting from improper installation, except those installations performed by Hillco.

Warranty Procedure

No warranty claims will be accepted without a completed Dealer PDI on file at Hillco.

For warranty submission instructions please email warranty@hillcotechnologies.com and request a Warranty Claim Form. Complete the Warranty claim form and submit the claim, via email to warranty@hillcotechnologies.com.

All warranty work must be performed, and claims submitted, within thirty (30) days of the occurrence of the claim and within the warranty period.

All parts removed during warranty repair should be held for a period of sixty (60) days after the warranty claim has been submitted to Hillco.

Hillco reserves the right to either inspect the product at the original retail purchaser's location, or the authorized Hillco's dealer's location; or require it to be returned to Hillco, transportation charges prepaid, for inspection.

For additional details on Hillco's Warranty Program refer to Hillco's current "Warranty Policy Guide".

Limitation of Liability

Hillco makes no express warranties other than those, which are specifically described herein. Any description of the goods sold hereunder, including any reference to buyer's specifications and any descriptions in circulars and other media published by Hillco is for the sole purpose of identifying such goods and shall not create an express warranty that the goods shall conform to such description.

THIS WARRANTY IS EXPRESSLY IN LIEU OF ALL OTHER WARRANTIES EXPRESSED OR IMPLIED. There are no implied warranties of merchantability or fitness for a particular purpose. This warranty states Hillco's entire and exclusive liability and buyer's exclusive remedy for any claim for damages in connection with the sale or furnishing of Hillco products, their design, suitability for use, installation, operation, or for any claimed defects herein. HILLCO WILL IN NO EVENT BE LIABLE FOR ANY INCIDENTAL OR CONSEQUENTIAL DAMAGES WHATSOEVER, NOR FOR ANY SUM IN EXCESS OF THE PRICE RECEIVED FOR THE GOODS FOR WHICH LIABILITY IS CLAIMED.

Neither representative of Hillco nor any dealer associated with Hillco has the authority to change the items of this warranty in any manner whatsoever, and no assistance to purchaser by Hillco in the repair or operation of any Hillco product shall constitute a waiver of the conditions of this warranty, nor shall such assistance extend or revive it.

Hillco reserves the right to make improvements in design or changes in specifications at any time, without incurring any obligation to owners of units previously sold.

D-230314ADB01

Model and Serial Number



Write the serial number and the model number of the leveling system and combine on the lines provided. It is important to reference these numbers when ordering parts or requesting technical support. We suggest that you give the leveling system serial number to your John Deere dealer to be kept with their combine serial number records.

Leveling System Model Number	JH7110	JH9110
Leveling System Serial Number	-	
Combine Model Number		
Combine Serial Number		

(circle one)

Maximum Header Weights

JH9110	9,500 lbs
JH7110	9,500 lbs

Hillco does not guarantee any non-John Deere header applications and will not be responsible for any damage incurred from improper header configurations.

Please call Hillco Technologies if you have any questions regarding the JH7110 & JH9110 or any other header configuration.

Introduction

Thank you for choosing the Hillco Technologies' Hillside Leveling System to compliment your farming operation. This product has been designed and manufactured to meet the needs of farmers wanting to increase the performance of John Deere S Series combines.

Safe, efficient and trouble free use of your Hillside Leveling System requires that you, and anyone else who will be operating or maintaining the leveling system, read and understand the safety, operation, and maintenance information contained in the Operator's Manual.

If extra copies of the operator's manual are needed, contact Hillco at 1-800-937-2461 or download it from Hillco Technologies' website at www.hillcotechnologies.com



Keep this manual handy for frequent reference and to pass on to new operators or owners. Call your Hillco dealer or Hillco if you need assistance or information at 1-800-937-2461.

OPERATOR ORIENTATION – The directions left, right, front, and rear, as mentioned throughout this manual, are as seen from the combine operator's seat and facing in the direction of forward travel.

SAFETY ALERT SYMBOL







This Safety Alert symbol means
ATTENTION! BECOME ALERT! YOUR SAFETY IS INVOLVED!

The Safety Alert symbol identifies important safety messages on the Hillco Leveling System and in the manual. When you see this symbol, be alert to the possibility of personal injury or death. Follow the instructions in the safety message.

SIGNAL WORDS

Note the use of the signal words DANGER, WARNING, and CAUTION with the safety messages. The appropriate signal word for each message has been selected using the following guidelines:

	DANGER - An immediate and specific hazard, which WILL result in severe personal injury or death if the proper precautions are not taken.
	WARNING - A specific hazard or unsafe practice, which COULD result in severe personal injury or death if proper precautions are not taken.
	CAUTION - Unsafe practices which COULD result in personal injury if proper practices are not taken, or as a reminder of good safety practices.
	NOTICE - is used to address practices not related to physical injury.

Operation Safety

1. Read and understand the Operator's Manual and all safety labels before operating the leveling system.
2. Make sure that all controls are in the manual position before starting the combine.
3. Clear the area of all bystanders, especially children, before starting the leveling system and during operation.
4. Make sure all safety shields are in place before operating the combine. Never operate the machine with the shields removed.
5. Keep hands, feet, hair and clothing away from all moving and/or rotating parts.
6. Stay seated in the cab during operation.
7. Operate controls only when sitting in the seat of the combine.
8. To avoid engine damage, do not run the machine for extended periods of time when it is in the leveled over position.
9. Always travel at a safe speed. Use caution when making turns or traversing ditches.
10. The leveling system is equipped with a maximum level warning lamp. This lamp indicates when the machine has reached its maximum leveling capability. There are restrictions as to tread width and tire selection for combines used in harvesting slopes greater than the maximum leveling capability of the leveling system.
11. The use of after-market grain tank extensions is prohibited from use on combines equipped with Hillco Leveling Systems.
12. Level Limit Stops should be used on combines that rely on the limit switches to stop the leveling prematurely to prevent sheet metal damage.

Hydraulic Safety

1. Do not search for high-pressure hydraulic leaks without hand and face protection. A tiny, almost invisible leak can penetrate skin, thereby requiring immediate medical attention.
2. Use cardboard or wood to detect leaks – never your hands!
3. Before inspecting the hydraulic system of the leveling system, install the safety stops.
4. Before operating the leveling system, ensure that there are no obstructions between the chassis and the carriage.
5. Maintain proper hydraulic fluid levels.
6. Ensure all fittings and hoses are in good repair.
7. Do not make any repairs to the leveling system hydraulic system including: valves, hydraulic hoses, adapters, pumps, manifolds, or reservoirs without first contacting your authorized Hillco dealer.



Service and Maintenance Safety

1. Review the Operator's Manual and all safety items before servicing or maintaining the leveling system.
2. Place the Auto/Off/Manual leveling switch in the "Off" position, stop the combine engine, wait for any moving parts to stop, block the tires, the header, and the cylinder areas before servicing, repairing, adjusting, or maintaining the leveling system.
3. Hydraulic oil is under pressure. Use caution when dealing with the hydraulic system.
4. Keep hands, feet, clothing and hair away from all moving and/or rotating parts.
5. Clear the area of bystanders, especially children, when carrying out any maintenance, repairs or making any adjustments.

Highway Operation and Transport Safety

1. Check with local authorities regarding combine transport on public roads. Obey all applicable regulations and laws.
2. Check clearance, elevations and widths of combine for travel near power lines, bridges, trees, etc.
3. Make sure the Auto/Off/Manual leveling toggle switch is in the "Off" position for all transport and highway travel situations.
4. Always travel at a safe speed. Use caution when making corners or meeting traffic.

Safety Labels

Familiarize yourself with the location of all safety labels. Read them carefully to understand the safe operation of your machine.

READ OPERATOR'S MANUAL SYMBOL

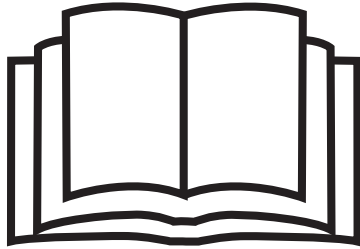

Decals, which display the Read Operator's Manual symbol, are intended to direct the operator to the Operator's Manual for further information regarding maintenance, adjustments and/or procedures for particular areas of the Leveling System. When a decal displays this symbol refer to the Operator's Manual for further instructions.

TO APPLY NEW OR REPLACEMENT LABELS

1. Make sure the label area is smooth by removing any debris such as dirt or old labels.
2. Wash the area with soap and water and then dry it thoroughly.
3. After the area has completely dried, peel the backing off the safety label and place it onto the cleaned area.
4. Make sure all areas of the label have adhered to the machine by pressing down on the entire face of the label, including the corners.

! DANGER



HYDRAULIC HAZARD

- Loss of hydraulic pressure may cause combine to tip.
- Read operator's manual before disconnecting any hydraulic components.

LL20-100788

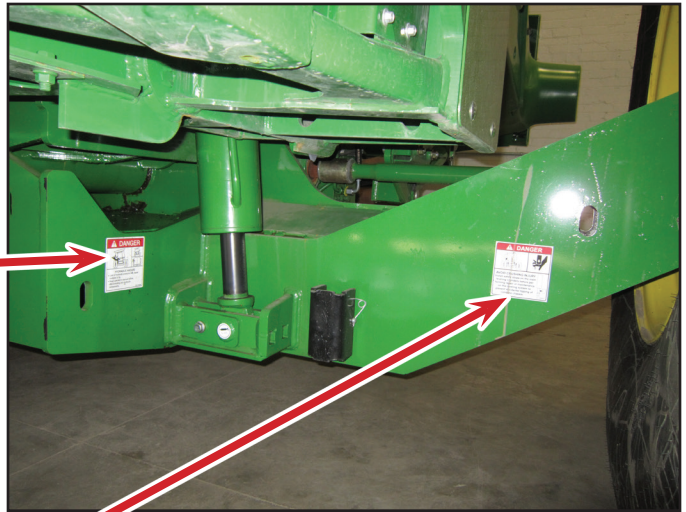

! DANGER



AVOID CRUSHING INJURY
Install safety stops on the main leveling cylinders before performing repair or maintenance on the leveling system to prevent accidental tipping of combine chassis.



LL-143621

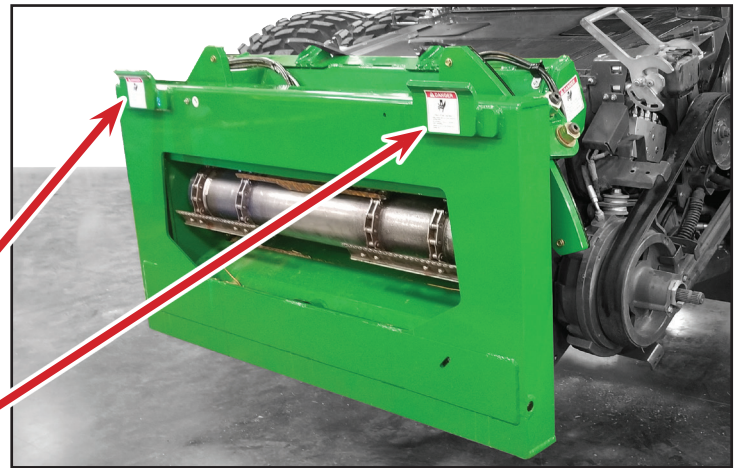

! DANGER



PINCH POINT HAZARD

- Keep hands, feet and body away from moving parts.
- Do not stand or climb on machine when operating.
- Hazard occurs during leveling and header trim.

LL20-100784

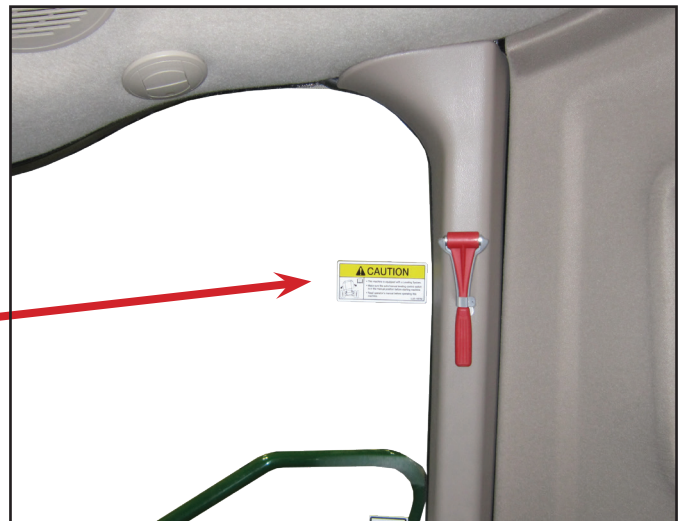

! CAUTION



- This machine is equipped with a Leveling System.
- Make sure the Auto/Manual leveling control switch is in the manual position before starting machine.
- Read operator's manual before operating this machine.

LL20-100782

! DANGER



CRUSHING HAZARD
To prevent serious injury or death:

- Keep all persons and objects clear while any part of this machine is in motion.

LL20-100783



! CAUTION



MOVING STEP HAZARD
Bottom step lowers and retracts upward.
Use caution when using ladder.

LL20-100785



! CAUTION



LEVELING SYSTEM HAZARD

- This machine is equipped with a leveling system.
- Combine chassis moves independent of carriage.
- Read operator's manual and be aware of hazardous areas at all times.

LL20-100787

! DANGER





HYDRAULIC HAZARD

- Loss of hydraulic pressure may cause combine to tip.
- Read operator's manual before disconnecting any hydraulic components.

LL20-100788



! DANGER

AVOID CRUSHING INJURY
Install safety stops on the main leveling cylinders before performing repair or maintenance on the leveling system to prevent accidental tipping of combine chassis.

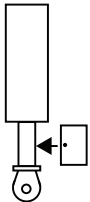

LL-143621

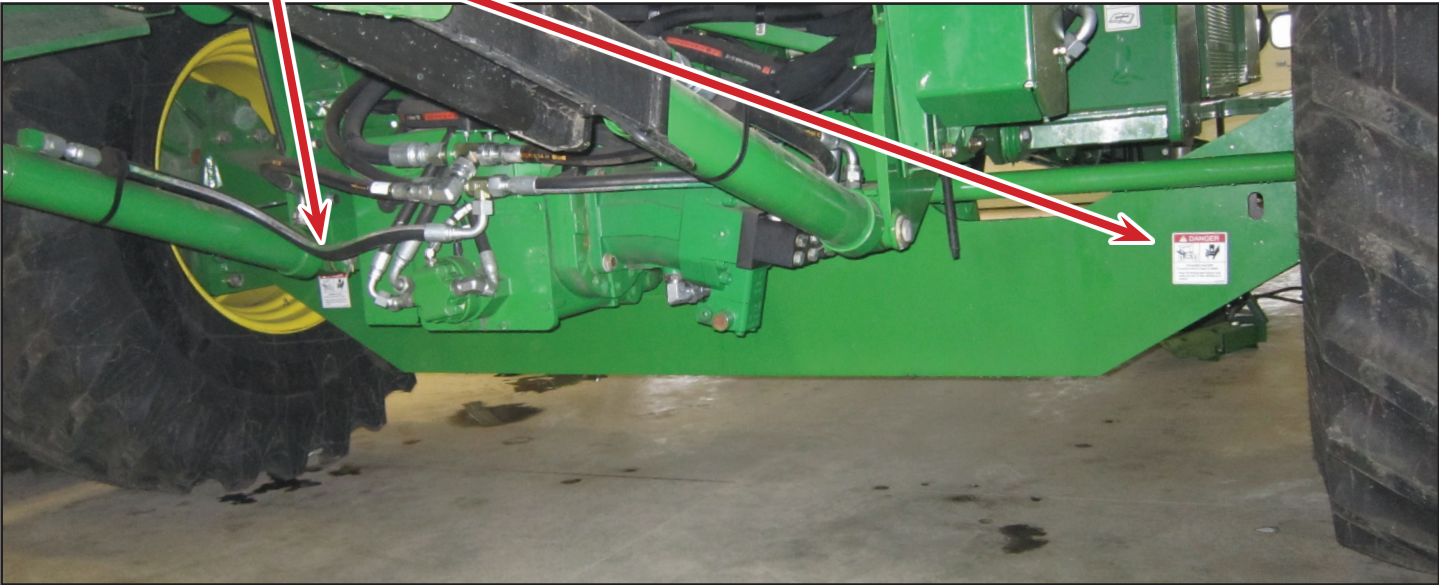

Product Description



The Hillco Hillside Leveling System is designed for John Deere S Series combines. Hillco designed the Hillside Leveling System to maintain the combine's threshing capacity and harvesting efficiency on contours of slopes up to 27%. This leveling system is designed to be installed with little modification to the combine.

The Hillside Leveling System tilts the combine's chassis laterally, automatically compensating for slopes up to 27% as it moves across sloping terrain. The threshing platform remains level and allows both the combine and the operator to perform at maximum efficiency.

The leveling system uses a clinometer to sense the combine's chassis position in relation to "level". As the combine moves onto a slope, the chassis leans out of level and the clinometer senses the deviation and sends a signal to the controller. The controller opens the appropriate leveling valve. The leveling valve allows hydraulic oil to flow into the leveling cylinder. The cylinders tilt the combine's chassis to correct for the tilt, bringing the chassis back to level.

As the combine's chassis levels, the master header tilt cylinder pushes hydraulic oil to the header tilt cylinder, which counter-rotates the header to keep it parallel to the ground. The operator can manually adjust the header's position or, alternately, may use the combine's original lateral tilt electronics and sensor-equipped header to automatically compensate for varying ground contours.

Controls and Components

Leveling Control Switches & Monitor

The leveling control switches (A) and Leveling System Monitor (B) are located on the far side of the John Deere Monitor.

Auto/Manual Leveling — The Auto/Manual leveling button is used to toggle between the Automatic and Manual Modes. In Manual Mode the chassis will not rotate until initiated by the operator. In Automatic Mode, rotation of the chassis is initiated by the controller as dictated by changes in the slope. The operator can momentarily override the controller using the Manual Left and Right Buttons. The combine will return to level once the button is released.

On the lower right corner of the monitor the leveling mode (Auto or Manual) is indicated.

Manual Tilt Left and Manual Tilt Right — These buttons allow the operator to rotate the chassis to the left or right as desired.

The monitor gives the operator feedback such as:

- Current Slope
- Current Modes
- Diagnostics
- Alarms

The operator can adjust settings such as:

- Left/Right Limits
- Level Zero point
- Manual Leveling Speed
- Joystick calibrations

Detail description of the monitor and adjustable settings are later in this manual.

For operation of the leveling system see the Operation section.



A - Leveling Control Switches
B - Leveling System Monitor



Hydraulic Gear Pump

The JH7110 has a Hydraulic Gear Pump (A) that is mounted directly to the output shaft of the combine's rear engine housing. It provides the necessary hydraulic flow to operate the leveling system's functions. The gear pump isolates the leveling system's hydraulic flow from the remaining combine's hydraulics.

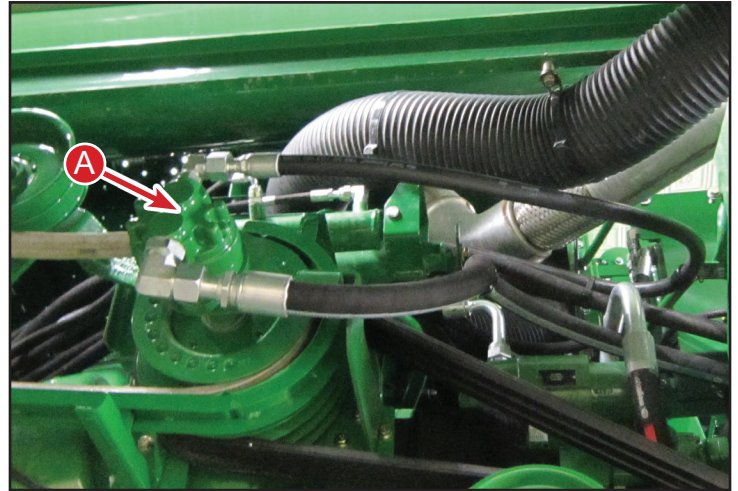

A - Gear Pump

JH9110 Hydraulic Flow

Hydraulic flow for the JH9110 leveling system is supplied from the Deere pressure supply line on the header height valve block (B). This valve is located on the left side of the combine below the cab. From this oil flows to the Hillco leveling valve located behind the inspection door on the operator's platform. Oil is returned from the leveling valve to header height valve block.

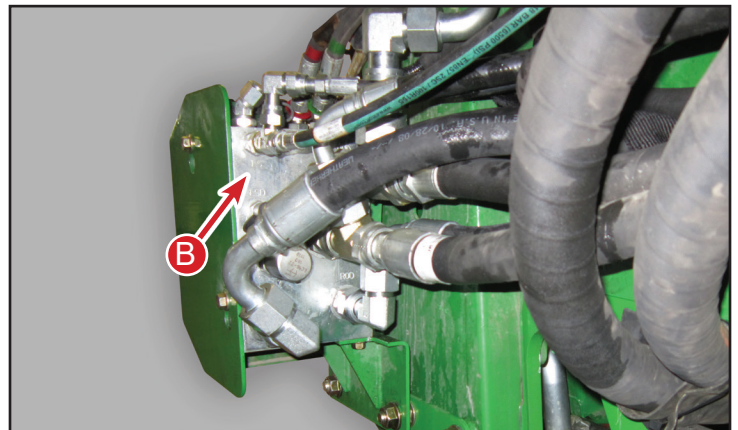

B - Header Height Valve Block

Leveling Control Manifold

The leveling control manifold (C) is located behind the inspection door on the operator's platform. The operator electronically activates the manifold by either pushing the manual leveling buttons or having it in automatic mode. The manifold diverts hydraulic flow to the corresponding leveling cylinder to rotate the chassis.

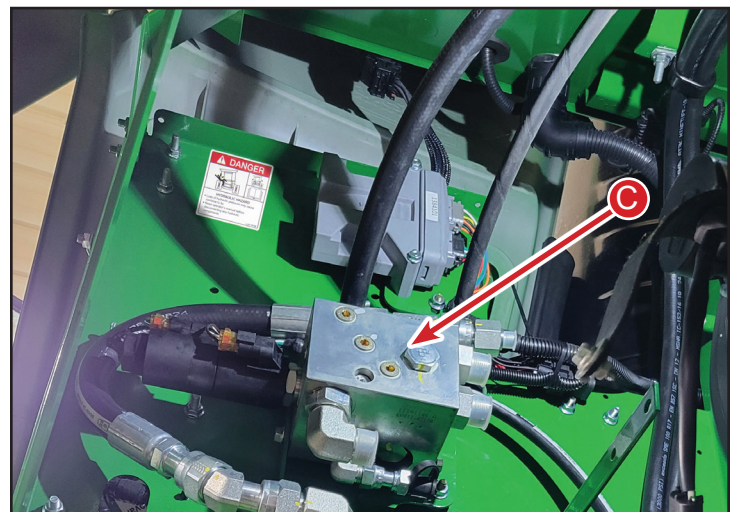

C - Leveling Manifold

Leveling Controller

The electronic leveling controller (A) is located behind the inspection door on the operator's platform above the leveling manifold. The controller processes slope information and outputs signals to the hydraulic leveling valve. When auto leveling is activated the leveling controller levels the chassis up to a maximum slope of 27%.

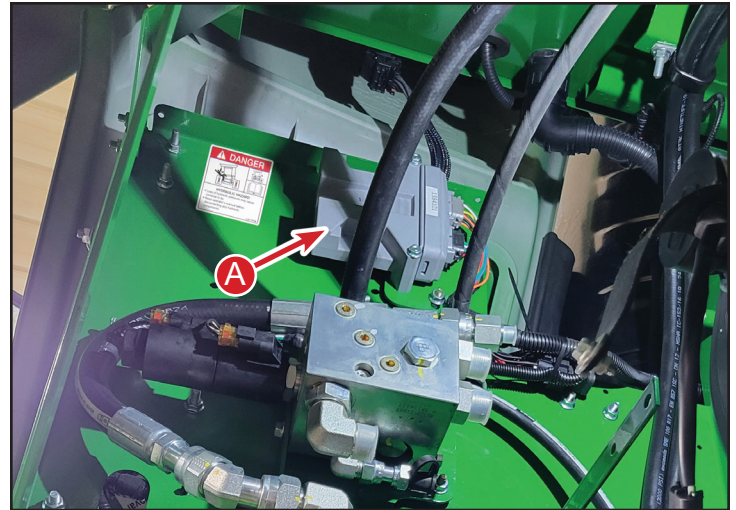

A - Leveling Controller

Header Tilt Manifold

Located on the left side of the feeder house is the header tilt manifold. This manifold diverts flow to the cylinder in the feeder house pivoting the header. The hydraulic valve fully integrates with the combine's electronics to provide auto lateral tilt. If the combine was originally equipped with Contour Master then the stock valve is used to control the header tilt.

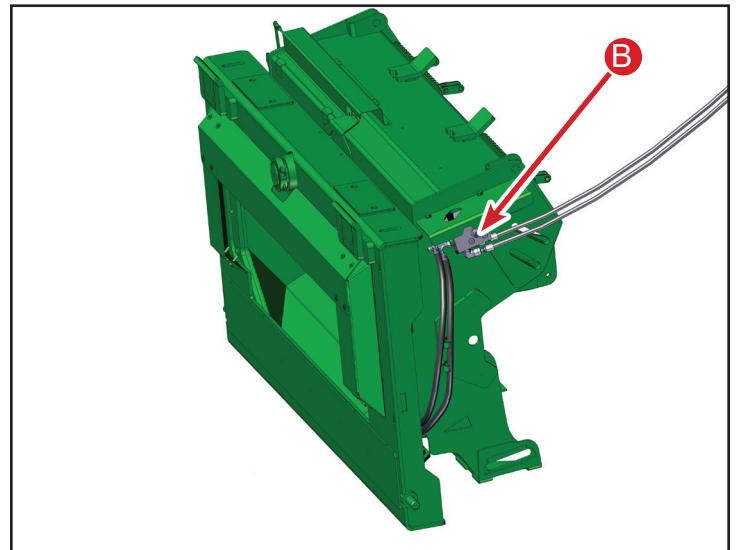

B - Header Trim Manifold

Overcarriage Position Indicator

Attached to the overcarriage and undercarriage is the position indicator (A). The position indicator outputs a signal to the controller of the overcarriage position relative to the undercarriage. This also acts as a maximum level indicator. When the combine is nearing maximum level the controller reduces the amps to the leveling valve decreasing the hydraulic flow. This provides for smooth leveling when achieving maximum level.



A - Overcarriage Position Sensor

Slope Sensing Clinometer

Located on the overcarriage near the Overcarriage Position Indicator is the Slope Sensing Clinometer (B). This clinometer outputs a signal to the controller. This output is a value that tells the controller the chassis' position relative to level.

This same clinometer also outputs a fore/aft slope reading. This signals an alarm that is displayed on the monitor when the combine is pointed down a hill that is greater than 20% and the rear wheel assist is engaged.

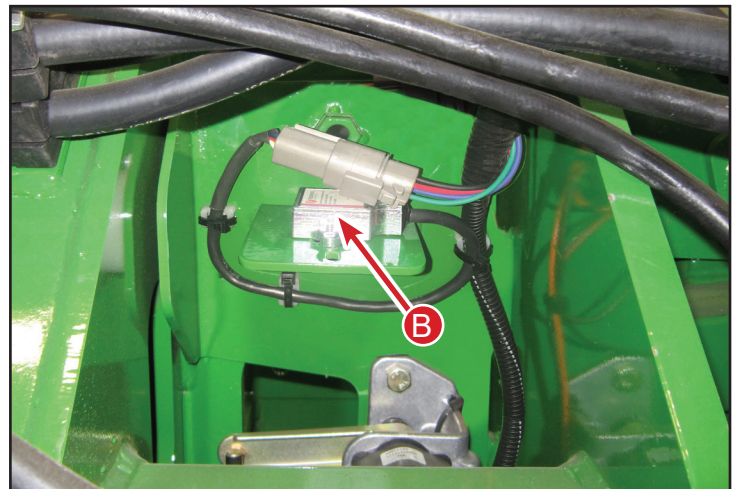

B - Clinometer

Transition

The transition is added to the front of the feeder house to pivot the header and allow it to follow the contour of the ground.

There are two transition options available. The paddle beater version and the beaterless which is pictured.

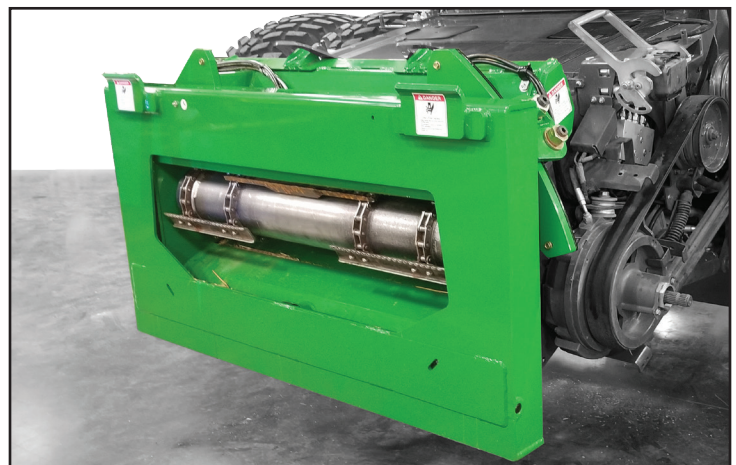

D - Beaterless Transition

Header Position Sensor

Located on the right side of the feeder house is the header position indicator. It utilizes a linkage between the face plate and the transition to indicate the header position relative to the combine. The position is then displayed in the corner post of the cab.

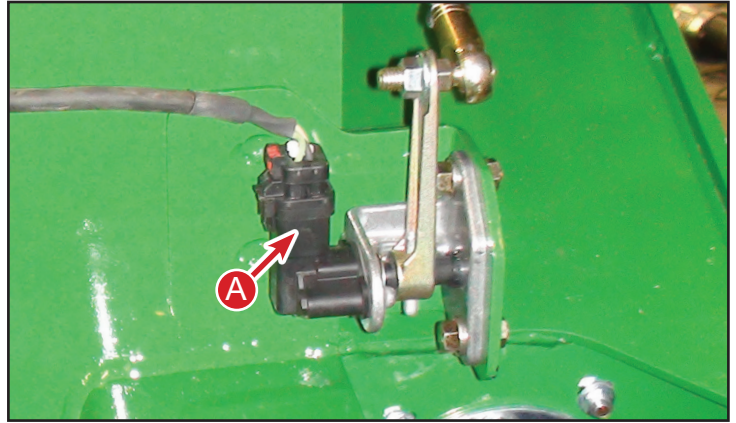

A - Transition Position Indicator

Mechanical Leveling Cylinder Stops

Some tire configurations may come into contact with the side panel when the combine is leveled over. Limit switches will prevent this contact, however, Hillco requires installing mechanical leveling cylinder stops. This will prevent damage in the event of hydraulic or electrical failure. After setting the carriage angle limits verify there is 1" between the tire and the closest contact point or 1/4" between the driveshafts and the leveling system chassis. Add cylinder stops to prevent the cylinder from over-leveling the combine. Contact Hillco for these cylinder stops.

Notice Set Carriage Angle Limits prior to installing Leveling Cylinder Stops.

Carriage

The carriage is designed to support the combine's chassis while allowing the combine to rotate through full range of motion. It consists of an undercarriage and an overcarriage. The drive wheels, final drives, and transmission are mounted to the undercarriage. The overcarriage bolts to the combine's axle and chassis. The leveling cylinders connect to the overcarriage and the undercarriage. The carriage raises the combine chassis eight inches to prevent the tires from coming into contact with the side panels.

Hydraulic Leveling Cylinders and Counter-Balance Valves

There are two leveling cylinders located on the rearward side of the leveling system's carriage. These cylinders are pressurized by the leveling hydraulic valve to tilt the combine chassis to correct for slope changes. Both leveling cylinders are equipped with built in hydraulic counter-balance valves that positively lock the oil into the cylinders until a pressure signal is sent from the hydraulic leveling valve. These counter-balance valves lock the chassis position in the event of hydraulic hose failure.

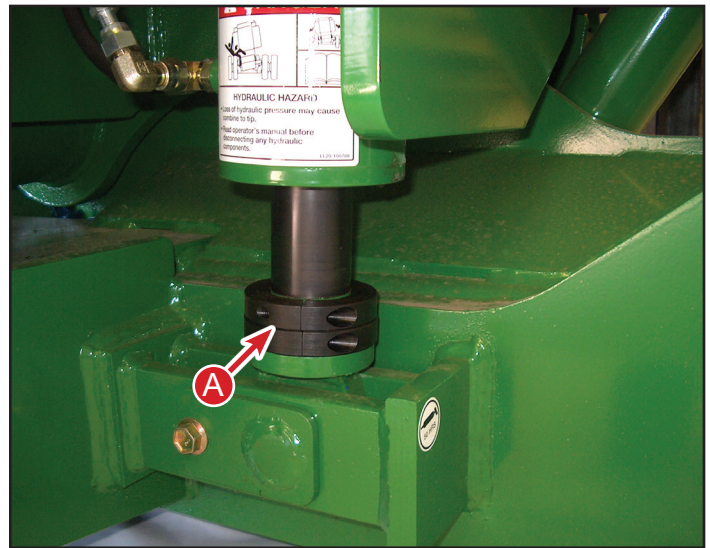

A - Mechanical Leveling Cylinder Stops
5/8 inch - Part # MC-137251
1/8 inch - Part # MC-137501

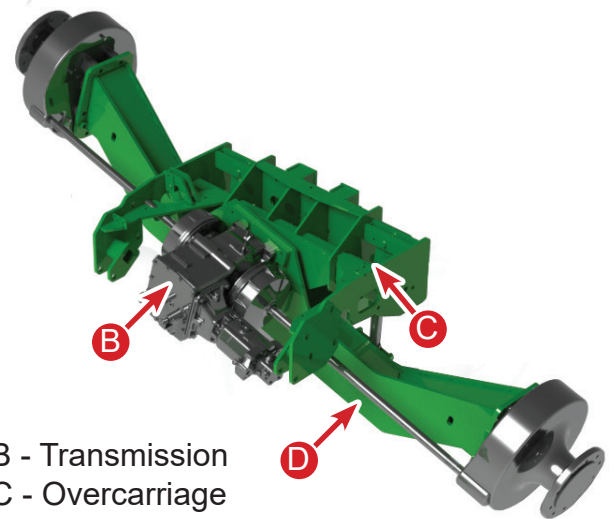

B - Transmission
C - Overcarriage
D - Undercarriage

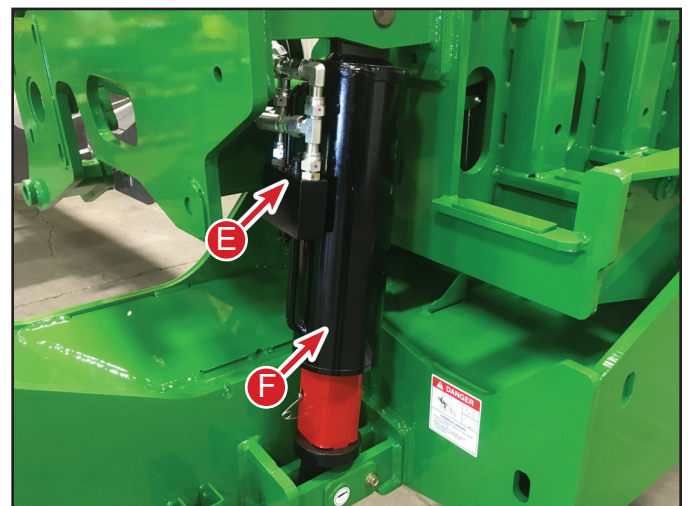

E - Counter-Balance Valve
F - Leveling Cylinders

Leveling Cylinder Safety Stops

When the leveling cylinder safety stops are installed on the leveling cylinders, the carriage cannot rotate. The stops must be installed before working on or around the leveling system and when hauling the combine. It is recommended that the stops be inserted during long-term storage. When the stops are not being used, they should be stored on the mount next to the leveling cylinder.

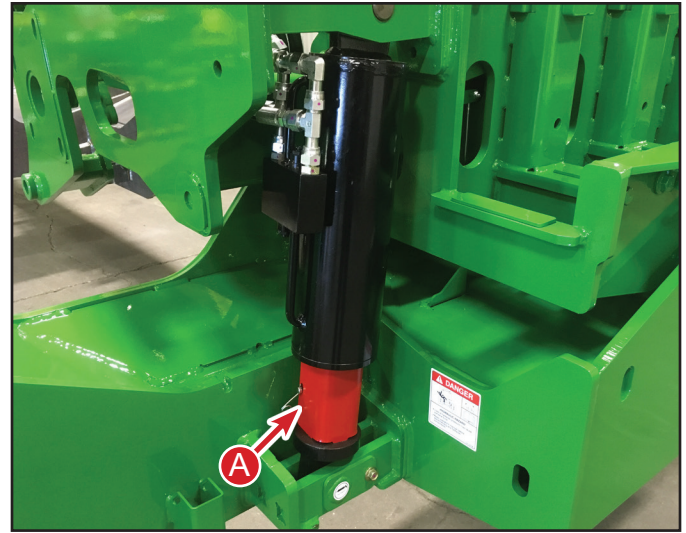

A - Cylinder Safety Stops
B - Cylinder Safety Stop Holder

WARNING

Install the cylinder stops before working on or around the leveling system. Failure to install the cylinder stops before working on or around the leveling system may result in sudden chassis rotation.

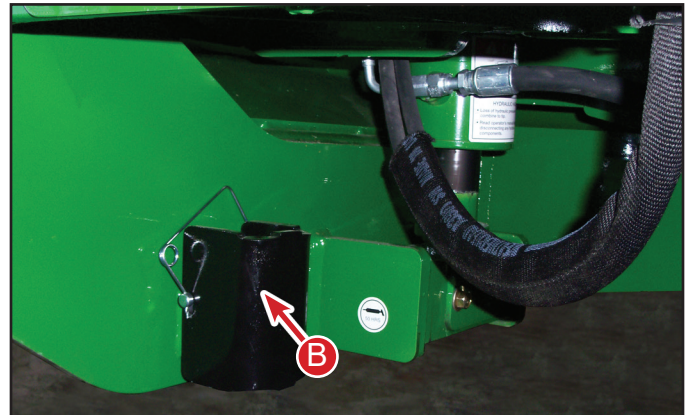

Drop Axle

The drop axle (C) raises the rear of chassis to match the height change due to the leveling carriage. The drop axle allows the rear axle to match the carriage's range of motion.

Drop axle wings (D) are installed for additional stability between the drop axle and the chassis.

Notice

Because of the increased rotation of the rear axle it is necessary to space the rear wheels out to avoid interference with shields. See the Rear Axle Spacing Chart for more information.

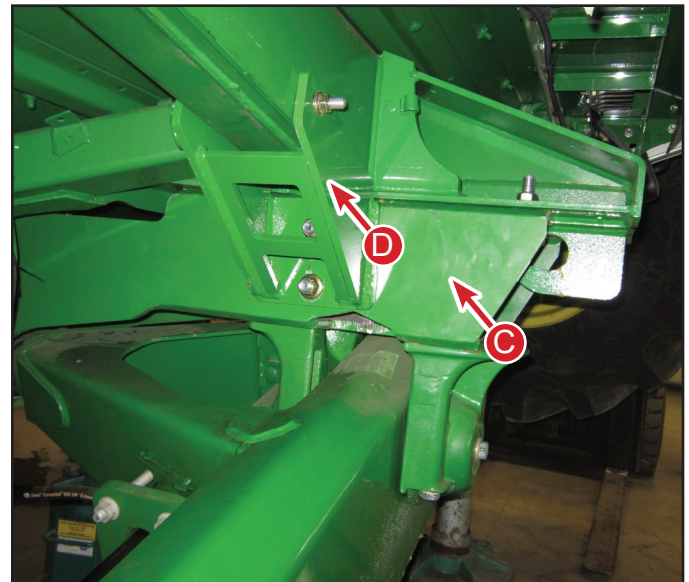

C - Drop Axle
D - Drop Axle Wing

Header Tilt Controls and Components

Header Tilt Control Switches

The manual header tilt switch is located in the hydro handle and is used to manually control the header tilt angle. Consult your John Deere Operator's Manual for explanation of the Contour Master operation.



A - Header Trim Switch
B - Master Cylinder

Header Tilt System

The header tilt hydraulic system consists of the header tilt control valve, master cylinder, slave cylinder, flow control, and relief valve. As the combine levels, the carriage extends or retracts the master cylinder, which sends oil to the slave cylinder. The slave cylinder counter-rotates the header. No electronic function is required for this action to occur.

The operator can manually trim the header angle with the header trim switch on the hydro control handle. In the Contour Master mode, the header angle is automatically trimmed by activating the lateral tilt valve, which is coupled to the master/slave circuit. In case the header contacts the ground, a relief valve prevents damage to the header and feeder house.

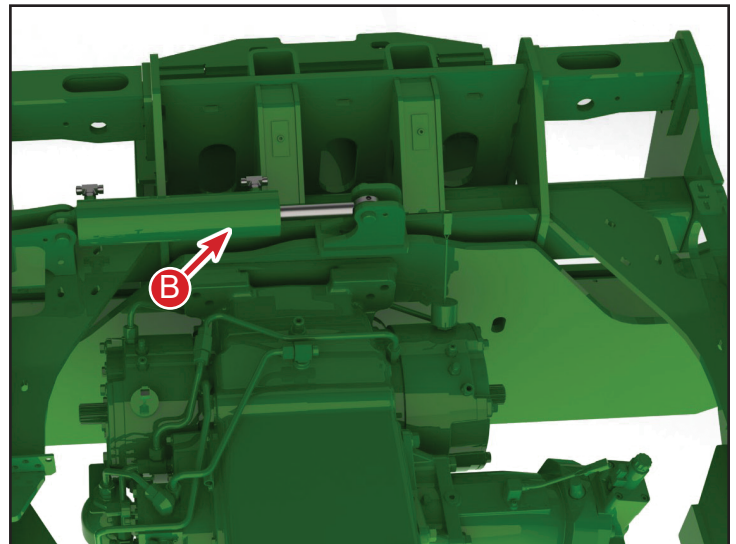

C - Slave Cylinder

Operation, Setup, and Maintenance



CAUTION

Before operating the leveling system, ensure that the leveling cylinder safety stops are not installed on the leveling cylinder. Operating the system with the safety stops installed may cause damage to the carriage, leveling cylinders, or stops.



CAUTION

Do not unload grain from the combine while operating the Leveling System in Automatic Mode. The chassis may tilt unexpectedly and cause damage to the unloading auger.

Operation, Setup, and Maintenance

Leveling System Controls

The leveling controls on the Home Screen are shown below. The monitor and controls are located to the right side of the Pro 700 monitor.

The Road/Field Mode (A) must be in the Field selection for leveling functions to work. If it is in the Road Mode then the leveling functions are disabled. Pushing combine's Road/Field button toggles the leveling system between Road and Field.

AUTO: Pushing the Auto/Manual Leveling Button (B) once will toggle between Auto & Manual. When Auto is showing on the display (C), this means automatic leveling operation is engaged. The automatic leveling controller monitors changes in slope and corrects chassis position to maintain a level chassis position. The Manual Left/Right Leveling Buttons (D, E) will override the automatic leveling controller while the switch is depressed. Upon release of the switch, the leveling system will return to automatic leveling mode.

MANUAL: Push the Auto/Manual Leveling Button (B) once to enter the Manual Leveling mode (Manual will be displayed). In Manual mode the Manual Left/Right leveling switches will level the combine left and right. When the switch is released the combine chassis will maintain its current position.



Notice
Monitor defaults to Manual each time system is powered up. This is done to prevent any accidental leveling.

Leveling Controls: Located on the right side of the JD monitor. These switches allow for Auto/Manual control (B) and Left/Right leveling (C, D).



- A - Auto/Manual Switch
- B - Auto/Manual Indicator
- C - Manual Left
- D - Manual Right

Maximum Level

The leveling system is equipped with a maximum level warning indicator on the monitor. On the Main Control Screen Max Level will be displayed. This indicates when the machine has reached its maximum leveling capability. Hillside Leveling Systems reach maximum level at 27%. Sidehills reach maximum level at 18%.



Header Trim Controls

The header trim switch is the four-position header control switch mounted in the combine's SR control lever. It is used to raise and lower the header as well as trim the header left and right.

TILT LEFT: Push the switch to the left to tilt the header counterclockwise.

TILT RIGHT: Push the switch to the right to tilt the header clockwise



Header Trim Switch

4WD Alarm

The 4WD Warning Alarm is located in the Leveling System Control Monitor. It will sound an alarm, a warning light will flash and 4WD Alarm will be displayed on the monitor if the combine is traversing down a slope that is greater than 20% and the 4WD is engaged. Disengage the 4WD and the warning will be cleared. On downhill slopes less than 20%, level ground or uphill slopes the warning will not come up if 4WD is engaged.

See your combine's Operator's Manual to understand how to operate the Rear Wheel Assist (RWA).



4WD Engage/Disengage

4WD Alarm will be displayed.



When the 4WD Alarm Sounds and Warning is displayed IMMEDIATELY DISENGAGE the Rear Wheel Assist or Control of the Combine COULD be lost.

Operator Adjustments

From the Home Screen, push the button (A) below Menu to enter the Main Menu.

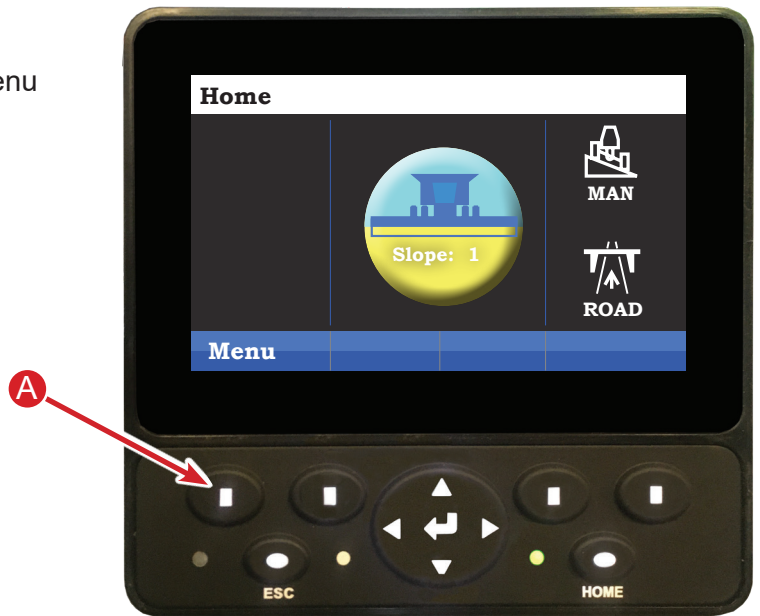

Push the up or down arrows (B) to move to the desired function. Once the desired function is highlighted press the Enter button (↵) (C) to go into that page. Press the Home button to go to the Home screen.



Operator Settings Menu

Select the desired Function in the Operator Settings Menu. Scroll up and down using the up and down arrows. When the desired function is highlighted select the enter button. To go back to the main menu select the Back button.



Manual Speed

The manual leveling speed can be sped up or slowed down (A). This setting only affects manual leveling and not auto leveling speed.

Adjust the green bar left and right using the left and right arrow buttons. To save your settings and return to the Operator Settings Page press the ESC button.

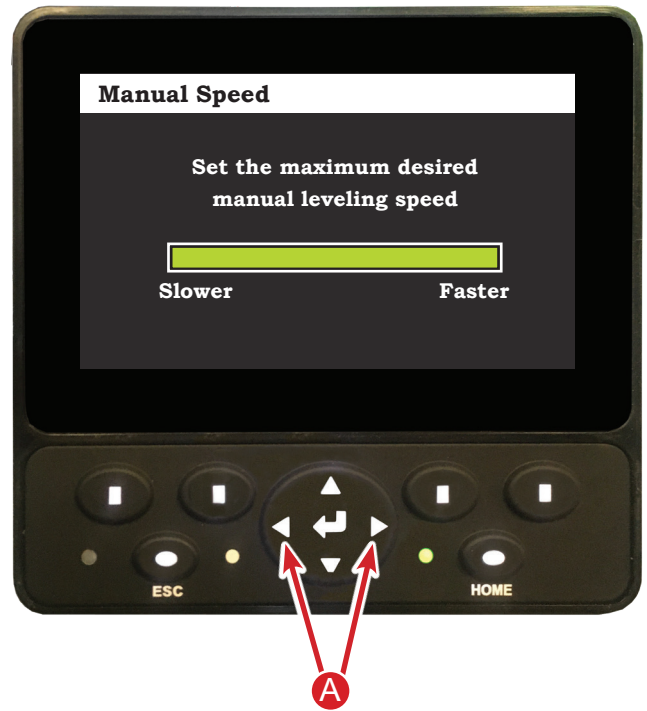

Display Backlight

The brightness can be adjusted up and down. Use the up and down arrows (B) to adjust the brightness and then hit Enter to save the setting.



Smart Unload

Smart Unload is an optional safety feature that puts the leveling system from auto leveling to manual leveling when unloading. This prevents the unloading auger from coming in contact with the grain cart while unloading on the go on changing terrain.

As soon as the unloading auger starts to swing out the system changes from Auto Leveling to Manual Leveling.

When the auger is in all the way the operator must cycle the auto manual switch to go back to auto leveling.

The setting is defaulted to OFF. If you wish to turn it on push the right arrow (A). The red OFF will turn white and the "On" will turn from white to green. To turn off, puch the left arrow. (B)

Press the ESC button to return to the previous screen.

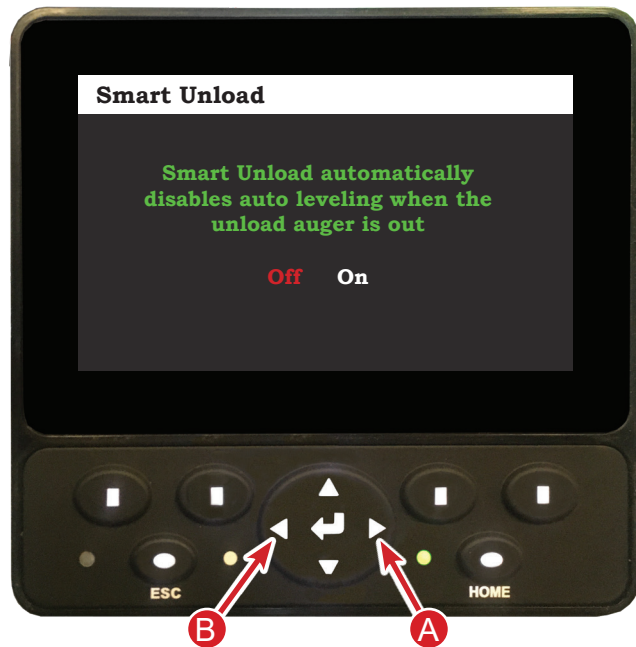

Calibration

From the main menu, using the up/down arrows (C), highlight calibration. Press enter (D).

Continued on next page.



After you select Calibration the message to the right appears.

Press Enter (A)

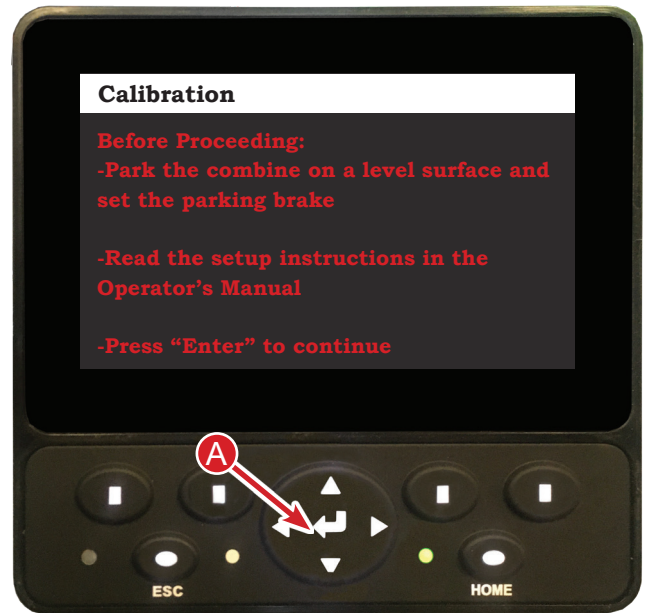

Joystick Calibration

Highlight Joystick and press Enter (B).

Notice When in the Calibration Menu screen all limits have been deactivated. The carriage can rotate until the cylinders bottom out.



With the Joystick in the center position press the Enter button (C).

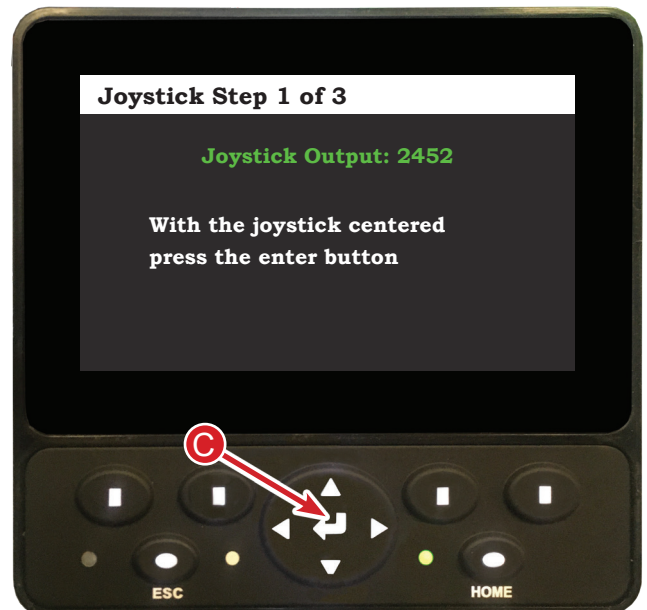

Push the Joystick lever all the way to the right and then press the Enter button (A).

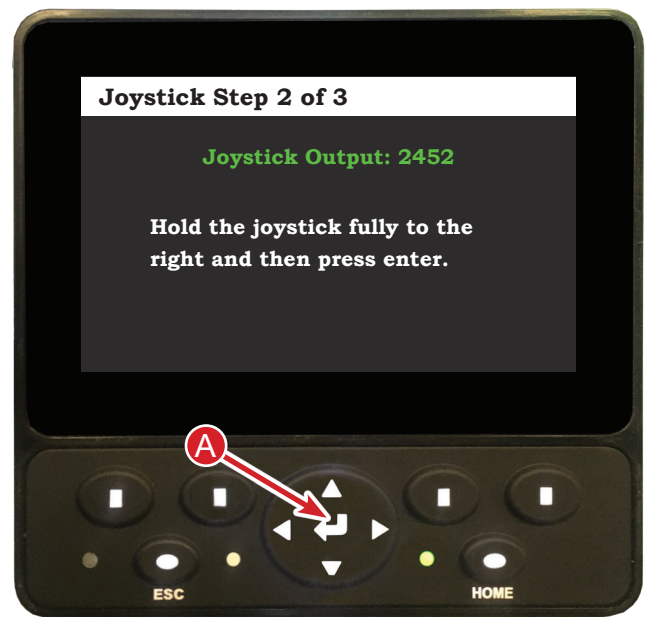

Push the Joystick lever all the way to the left and then press the Enter button (B).

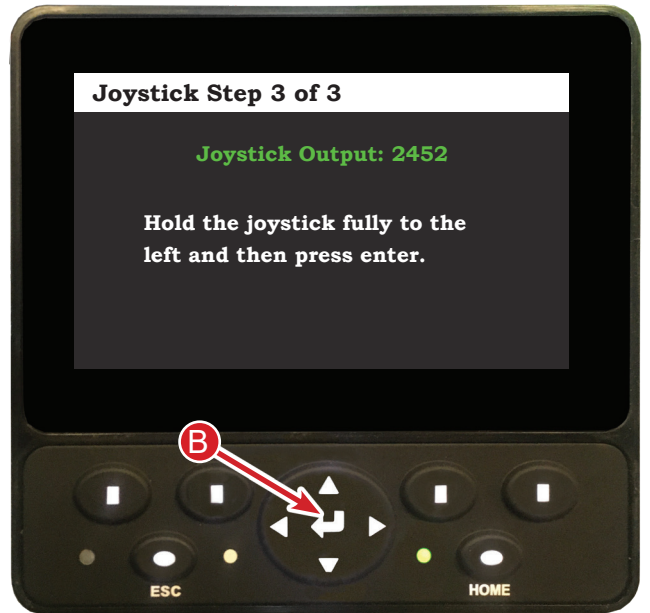

The screen will show the calibration is saved. Joystick Calibration is now complete. Press the ESC button (C) to return to the calibration menu.

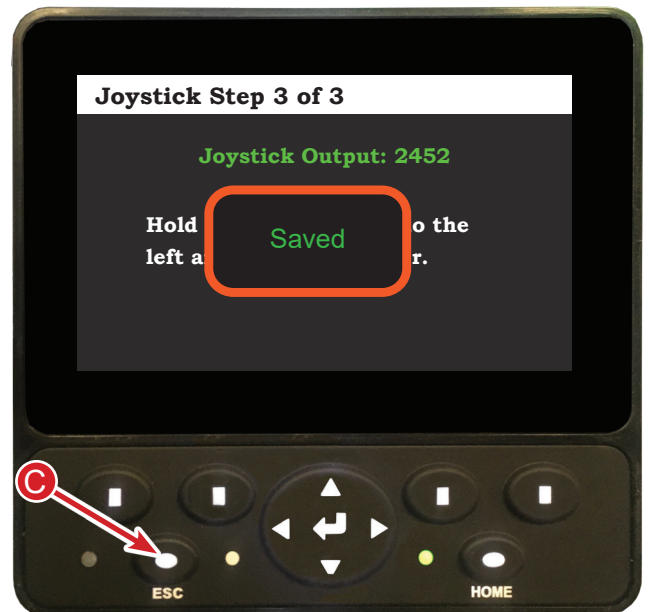

Left/Right Clinometer Calibration (Level Zero Point)

From the Home Screen select Main Menu. Then select Calibration Menu.

Using the up/down arrows, highlight Left/Right Clinometer and press Enter (A).



Follow the directions on the screen. When the combine is level side to side press Enter (B).

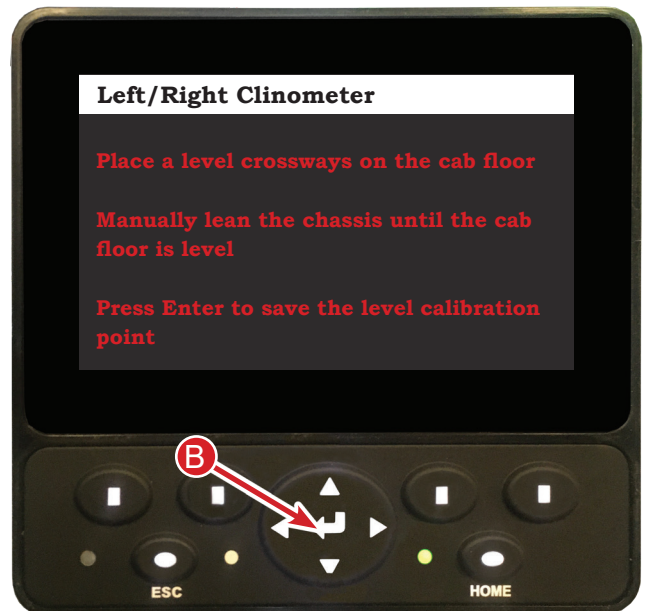

The screen will show the limit has saved. Press ESC (C) to return to the calibration menu.

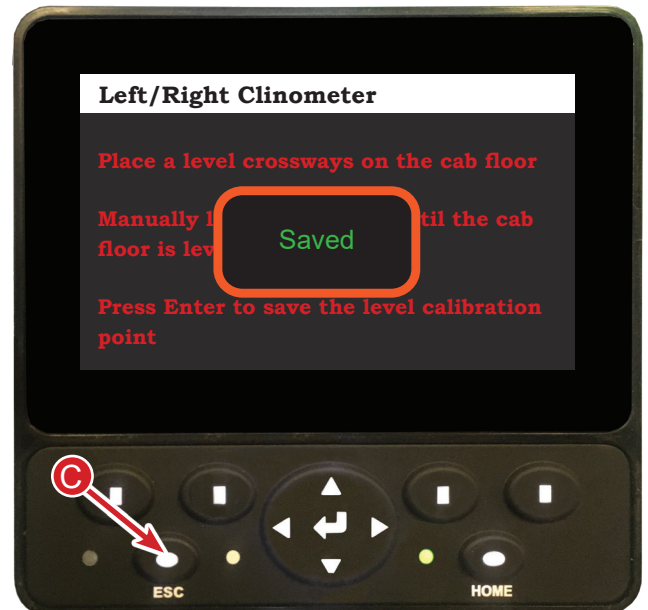

Carriage Angle Left Limit

This setting sets the maximum tilt to the left.

To set the carriage angle left limit, park the combine on level ground and set the parking brake. Then raise the feeder spout and drop the header lift cylinder safety stop.

Select the Carriage Angle Left Limit and press Enter (A) from the Calibration Menu.

Lean the combine to the left until either the maximum leveling capabilities of the leveling system are reached or contact is made between two points. The software will automatically set back approximately one inch.

When maximum level has been achieved press the Enter button (B). When saved is displayed, hit ESC (C) to return to calibration menu.

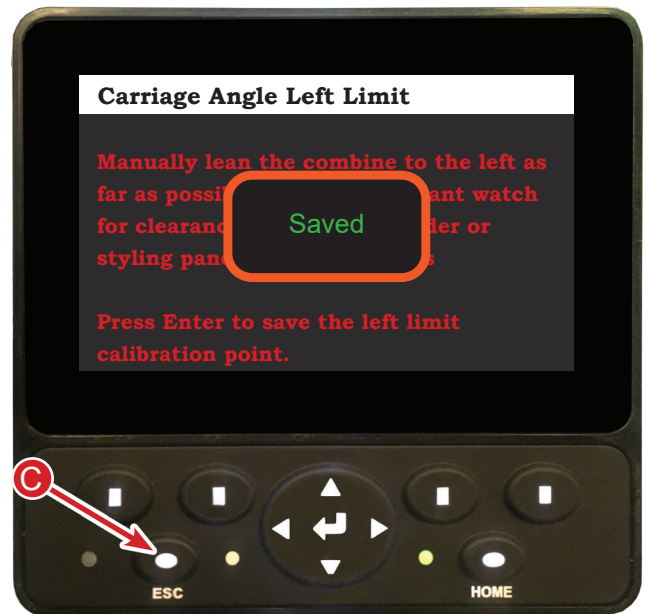
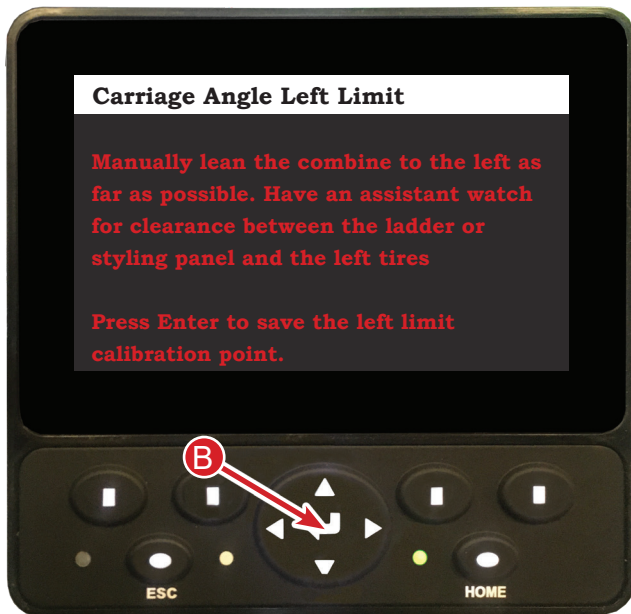

Notice

With certain tire selections the limit sensors can be used to prevent the need to modify the sheet metal on the left and right side panels of the combine. Installation of level limit stops is recommended to prevent sheet metal damage in the event of a limit switch failure. (See LEVEL LIMIT STOPS section)

Notice

If Level Limit Stops are used be sure that the left limit sensor has been calibrated with that stop in place. Damage to the cylinders or other leveling system components may occur if sensors aren't set properly.

Carriage Angle Right Limit

This setting sets the maximum tilt to the right.

To set the carriage angle left limit, park the combine on level ground and set the parking brake. Then raise the feeder spout and drop the header lift cylinder safety stop.

Select the Carriage Angle Right Limit and press Enter (A) from the Calibration Menu.

Lean the combine to the right until either the maximum leveling capabilities of the leveling system are reached or contact is made between two points. The software will automatically set back approximately one inch.

When maximum level has been achieved press the Enter button (B). When saved is displayed, hit ESC (C) to return to calibration menu.

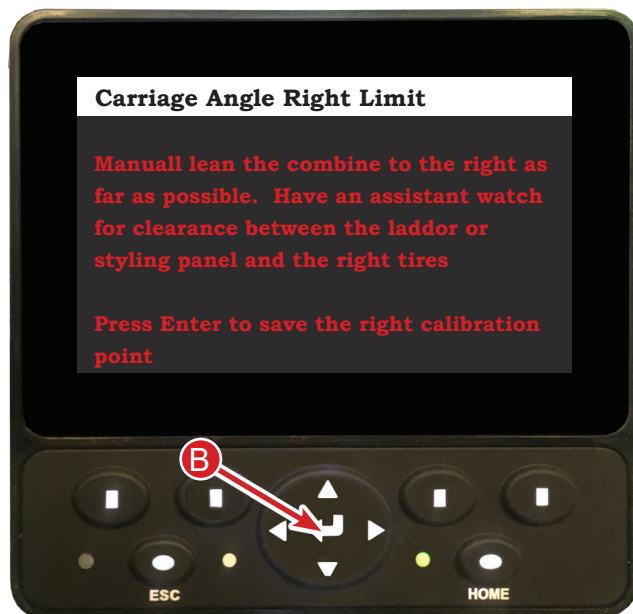
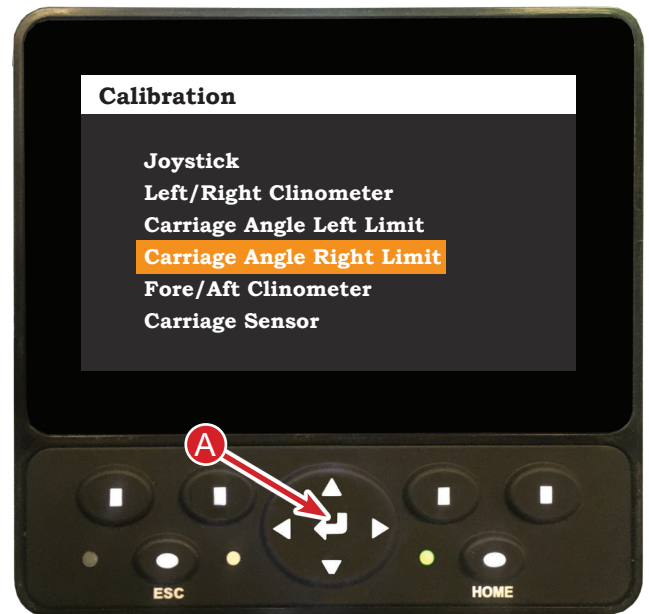

Notice

With certain tire selections the limit sensors can be used to prevent the need to modify the sheet metal on the left and right side panels of the combine. Installation of level limit stops is recommended to prevent sheet metal damage in the event of a limit switch failure. (See LEVEL LIMIT STOPS section)

Notice

If Level Limit Stops are used be sure that the left limit sensor has been calibrated with that stop in place. Damage to the cylinders or other leveling system components may occur if sensors aren't set properly.

Fore/Aft Clinometer

Using the up/down arrows highlight Fore/Aft Clinometer and press Enter (A).



When the combine is level front to back press Enter (B).

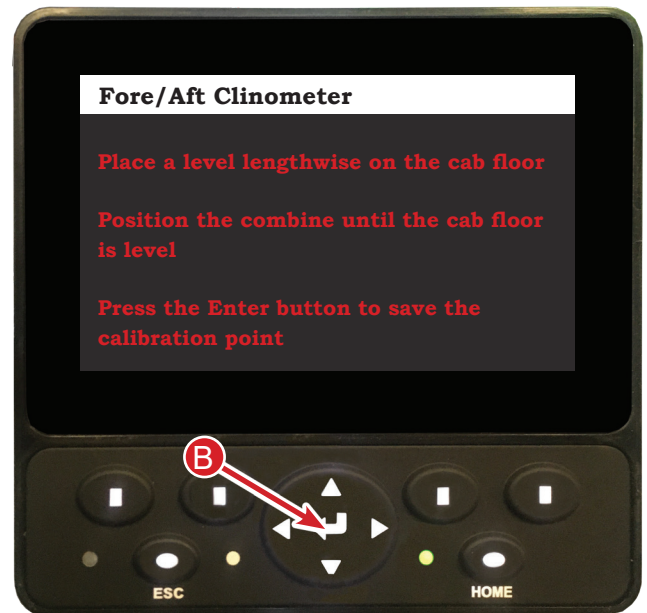

The screen will show saved. Press ESC (C) twice to return to the Main Menu.

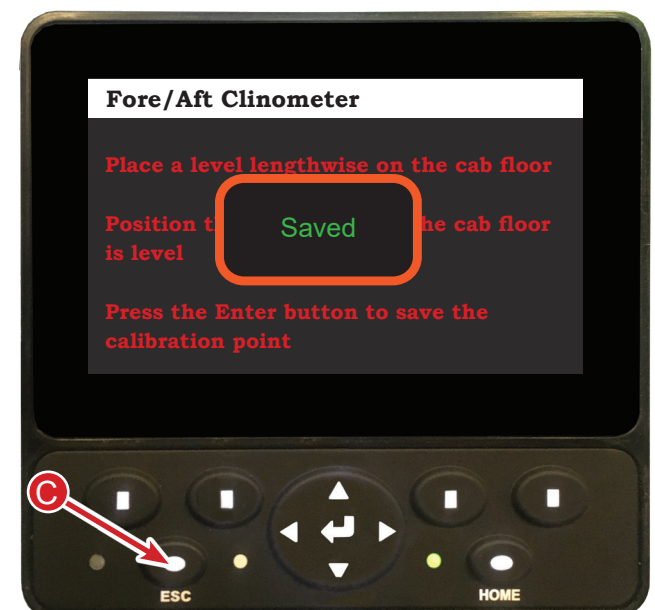

Carriage Sensor

Using the up/down arrows highlight Carriage Sensor and press Enter (A).



When the combine is on a level surface and the cab is level, Press Enter to Save. (B).



The screen will show saved. Press ESC (C) to return to the calibration menu.

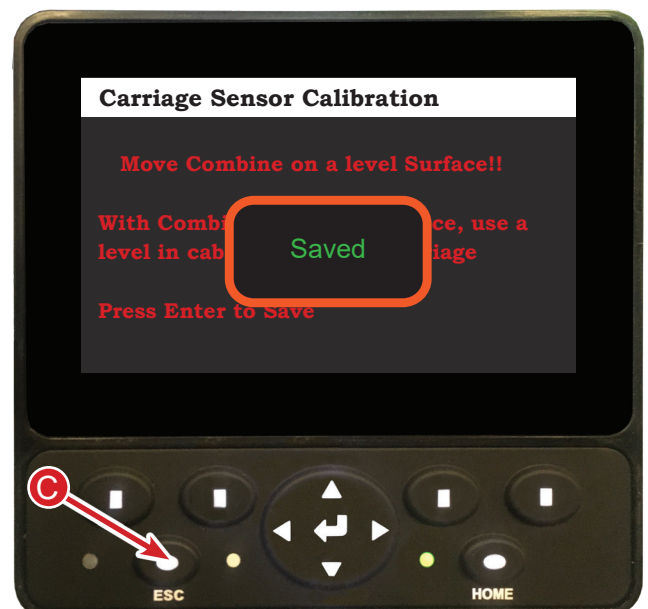

Left PWM Calibration

Using the up/down arrows highlight Left PWM Calibration and press Enter (A).



Make sure the machine is level. Press enter (B) to start the calibration process. The number on the last line in green will begin counting. The machine will dip slightly to the left once cracking has been achieved.

Always be ready to press ESC in case of failure.

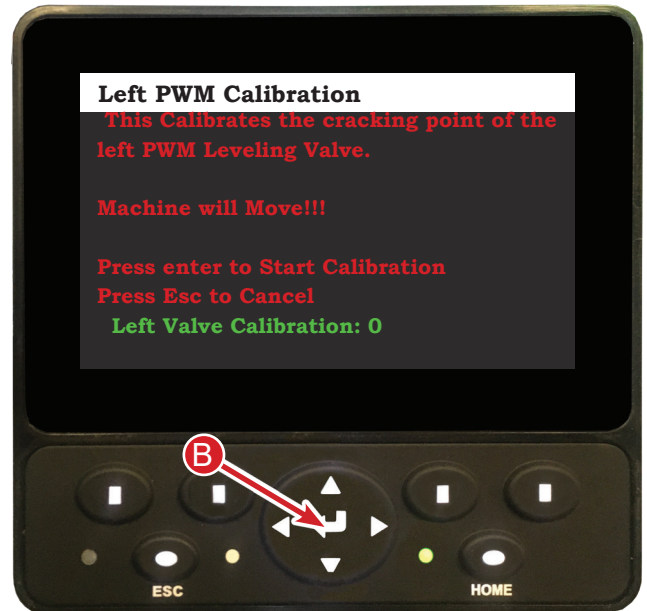

The machine will move slightly to the left and the Calibration value will stop counting. At this point, calibration is done. Press ESC (C) to return to the calibration menu.

* Value shown is an example

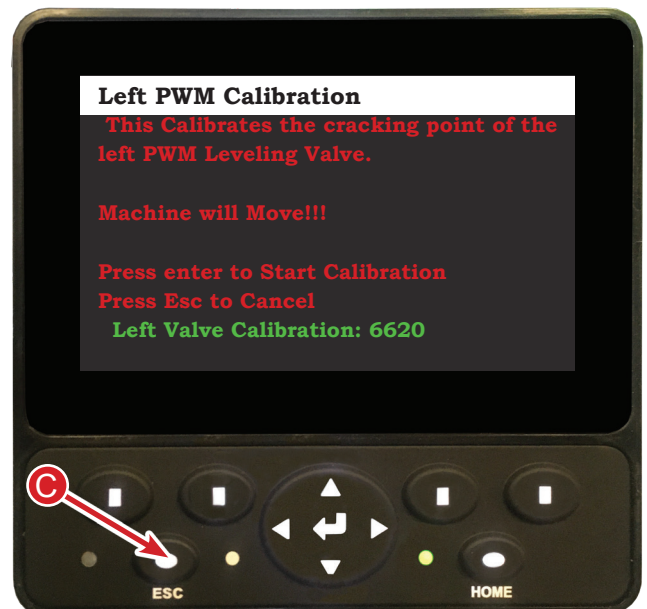

Right PWM Calibration

Using the up/down arrows highlight Right PWM Calibration and press Enter (A).



Make sure the machine is level. Press enter (B) to start the calibration process. The number on the last line in green will begin counting. The machine will dip slightly to the left once cracking has been achieved.

Always be ready to press ESC in case of failure.

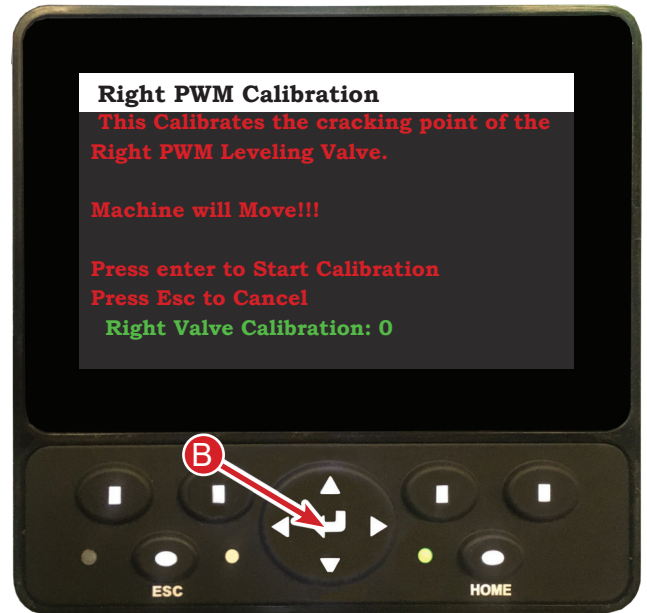

The machine will move slightly to the right and the Calibration value will stop counting. At this point, calibration is done.

This completes Calibration. Press ESC (C) twice to return to the main menu.

** Value shown is an example*

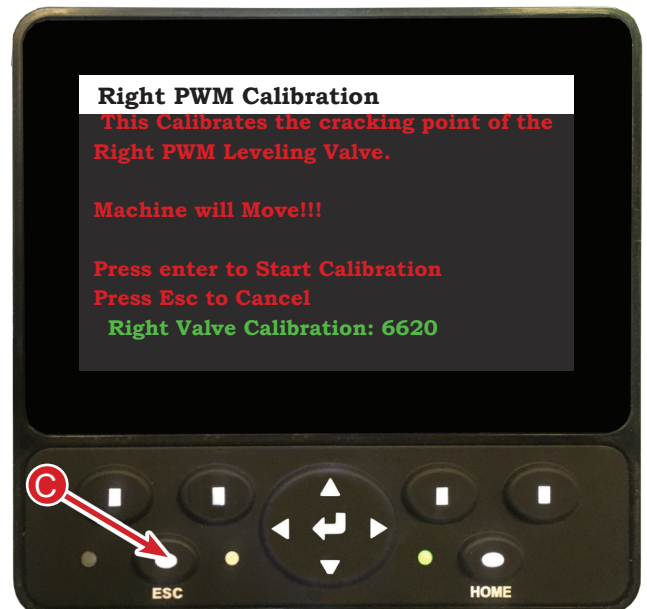

Diagnostics

From the Main Menu highlight Diagnostics using the up/down arrows. Press Enter (A) to enter the diagnostics menu.

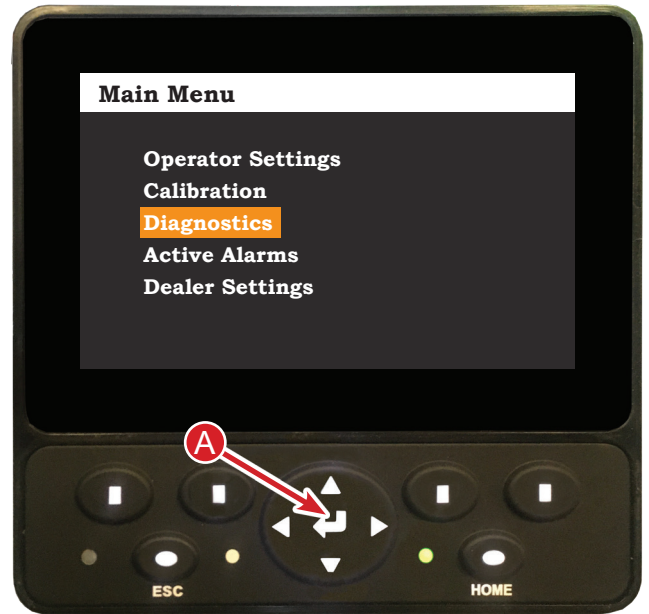

The Diagnostics menu allows the operator to view output information from the electrical system on the leveling system.

Using the up/down arrows, highlight Clinometers and press Enter (A) to view the output of the clinometers.

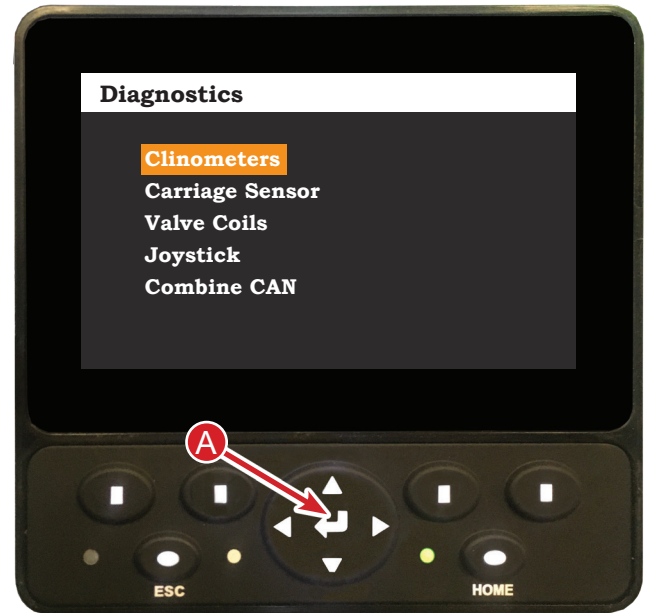

Clinometers

Fore/Aft (B) shows the current clinometer output. By driving up or down a hill this value will change.

Left/Right (C) shows the current clinometer output. By leveling the combine back and forth the values will change.

The value for Level Zero Setpoint and 4WD Zero Setpoint (D) are the current calibration values. These values are set in the Calibration screen under Left/Right Clinometer and Fore/Aft Clinometer.



Carriage Sensor

The Carriage Sensor Output is the current voltage output at a given carriage position.

Leveling the combine back and forth will change this value. Leveling to the right will increase the value.

The value for Left and Right Limit Setpoint (A) are the current calibration values for maximum level to both sides.



Valve Coils

Range is from 0-18000.

Only one coil will be activated at a time.

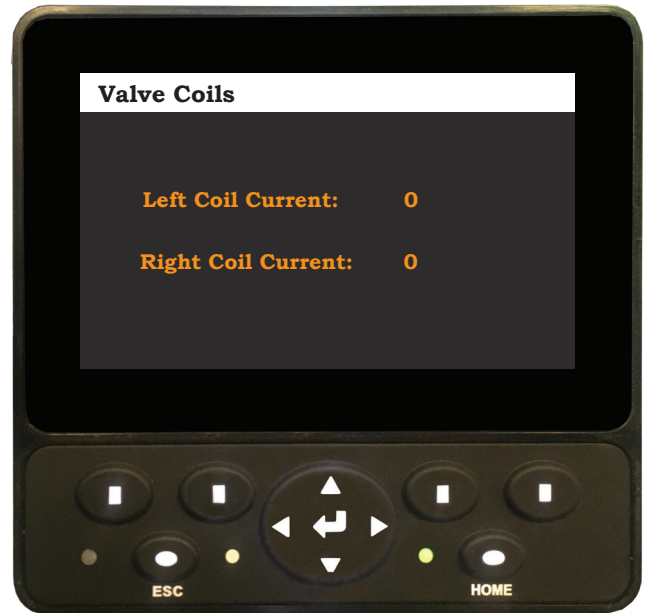

Joystick

Range is from 500-4500.



Combine CAN

The Signal can be OFF, ON, or “ - - - “.

“ - - - “ means the display is not receiving the CAN message. Off will be red and On will be green.



Active Alarms

From the Main Menu highlight Active Alarms using the up/down arrows and press ENTER (A).



If you have an Active Alarm the warning icon will appear on the home screen in the upper left corner.



The Active Alarms that will appear are:

- Clinometer Fault
- Carriage Sensor Fault
- Joystick Fault

If any of the sensors output fall outside of the expected range an alarm will trigger on the screen listing the fault and the current output of the sensor in question. While the alarm screen can be cleared the automatic function of the leveling system may be disabled until the fault is corrected. Once an alarm screen has been cleared the fault condition is denoted by an alert icon in the top left of the screen. If the icon is displayed then the active alarms screen in the system menu will show which sensors are in a fault condition.



Carriage sensor Fault



Clinometer Fault



Joystick Fault



Dealer Settings

Dealer Settings is a password protected screen that is for dealers to make adjustments to the leveling system.



Password protected page:





CAUTION

Before driving the combine into a building, ensure that the leveling system is in the road transport mode. This will ensure that the combine does not unexpectedly level. Unexpectedly leveling may cause damage to the building or the combine.

Storage

When storing the combine between seasons, Hillco strongly recommends that the leveling cylinder safety stops are installed on the leveling cylinders. This will ensure that the combine does not settle during storage.

Transporting Combine on a Trailer

Before loading the combine, switch the leveling system into manual mode and install the cylinder stops. This will ensure that there are not any unexpected weight shifts during the loading process. In addition to the Tie Down locations on the combine, Hillco provides T-hook slots (B) on the undercarriage for securing combine to the trailer.

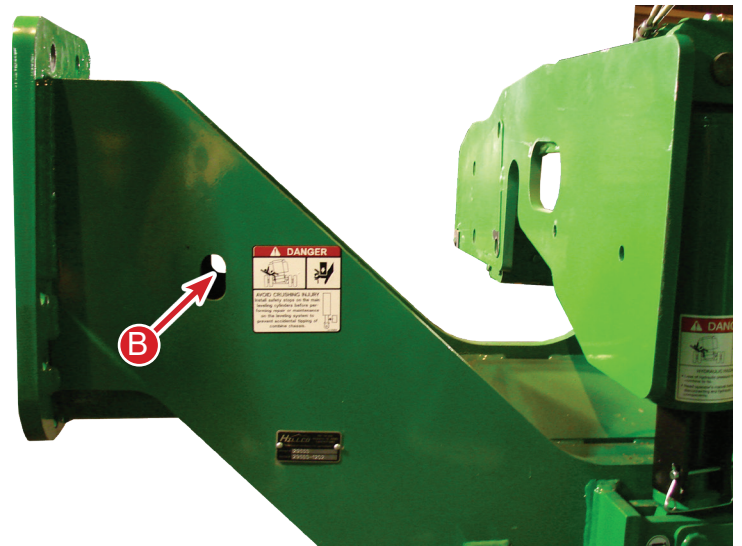

Maintenance

Carriage

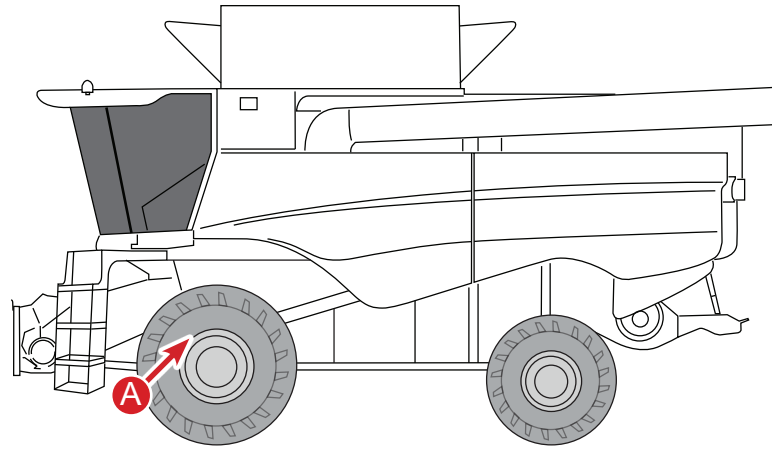

Recommended Grease: NLGI Multi Purpose Grease

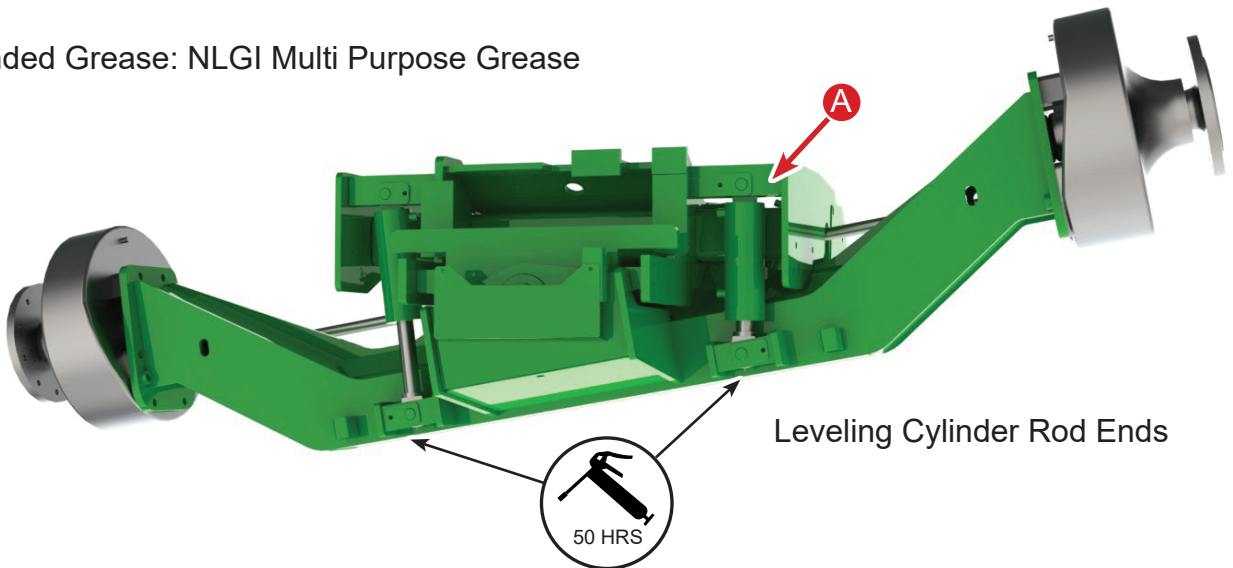

Leveling Cylinder Rod Ends

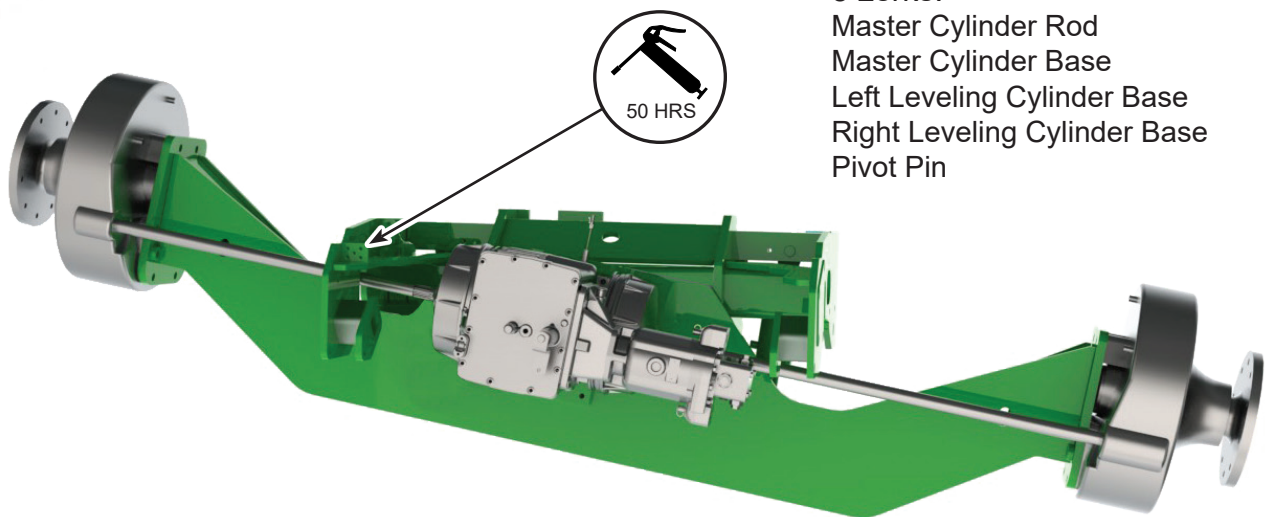

5 zerks:

- Master Cylinder Rod
- Master Cylinder Base
- Left Leveling Cylinder Base
- Right Leveling Cylinder Base
- Pivot Pin

Beaterless Transition

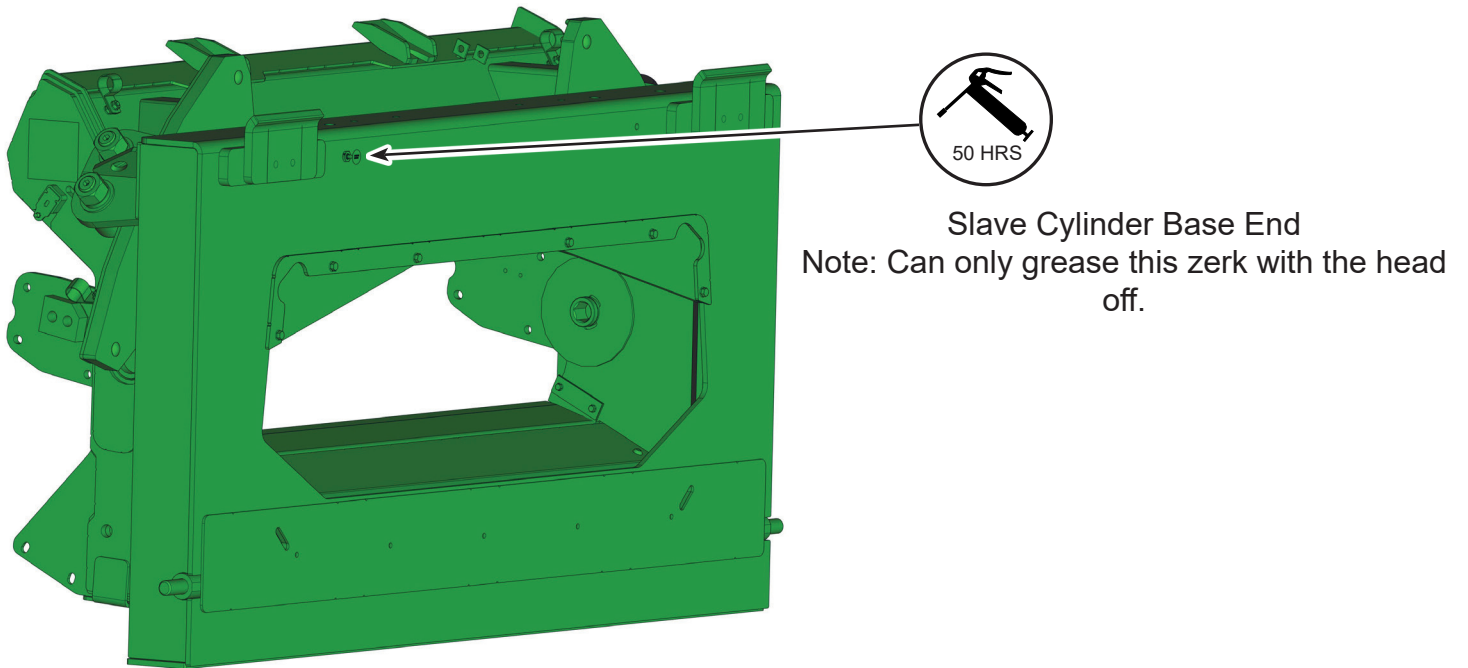
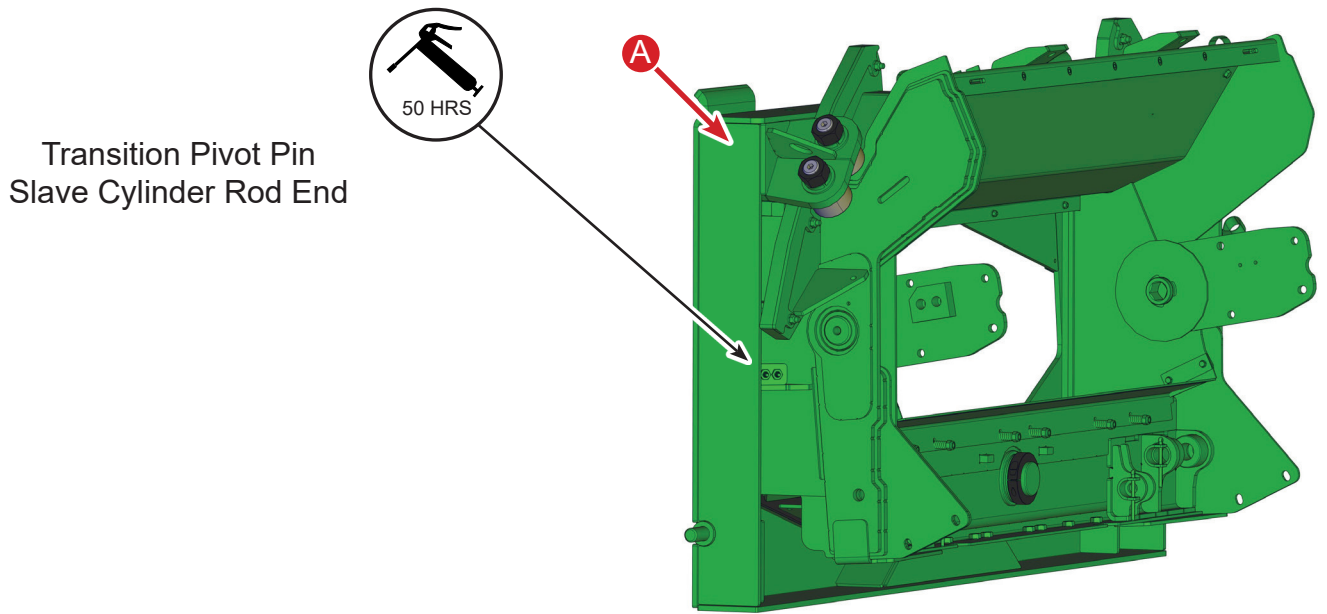
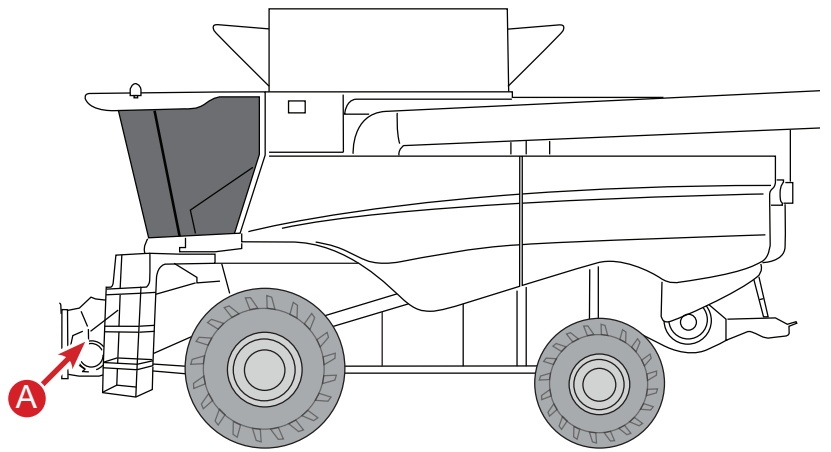

Paddle Beater Transition

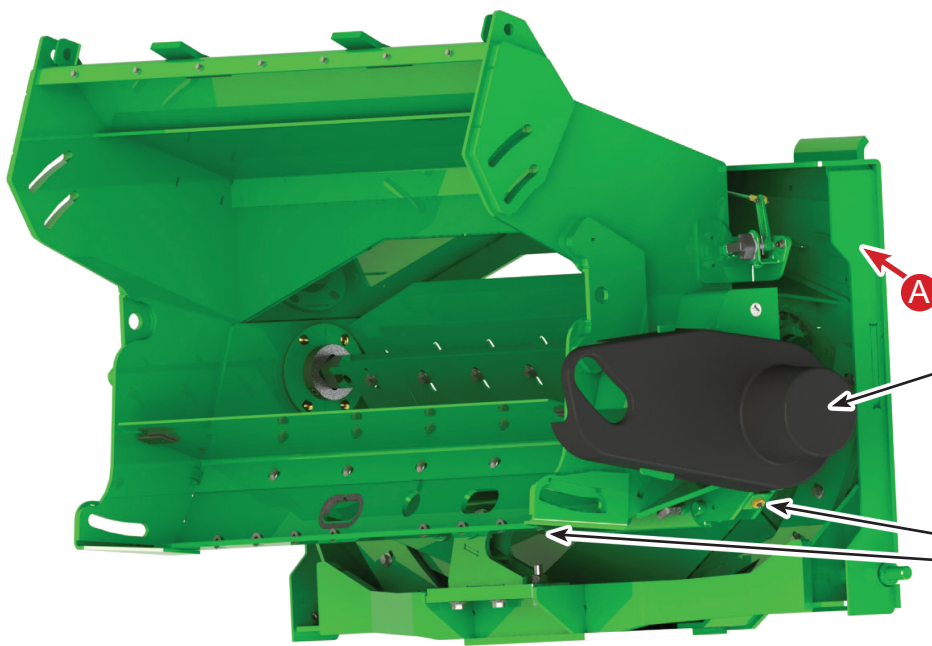
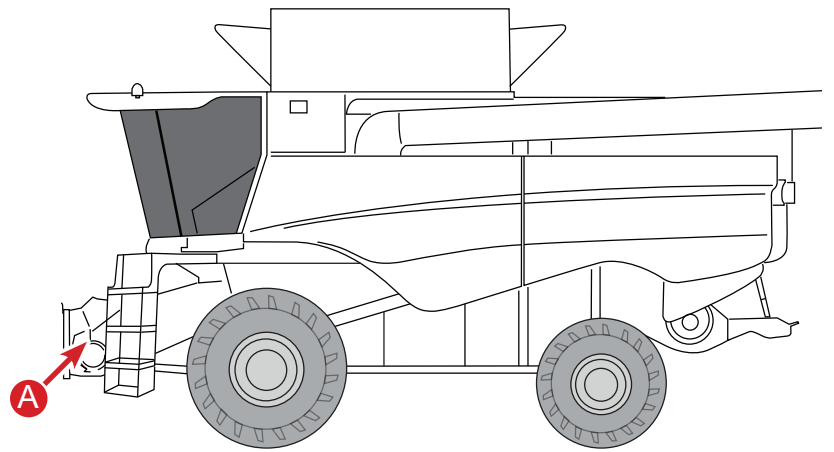

Paddle Beater Slip Clutch Grease on 50 hour interval with little to no slippage. Grease daily in adverse feeding conditions where slippage may occur more often. Pump until grease comes out.



Master and Slave Cylinder Spherical Bearings

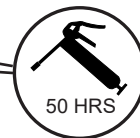

Right Paddle Beater Bearing

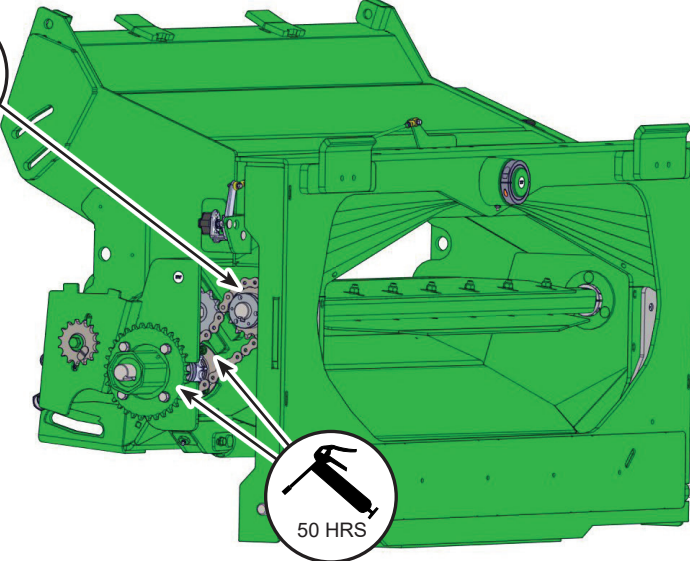

Paddle Beater Jack Shaft Bearings (2)



Pivot Pin

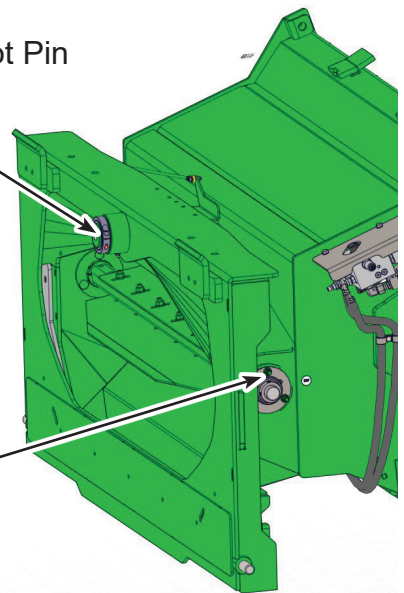

Left Paddle Beater Bearing

Hydraulic Filter

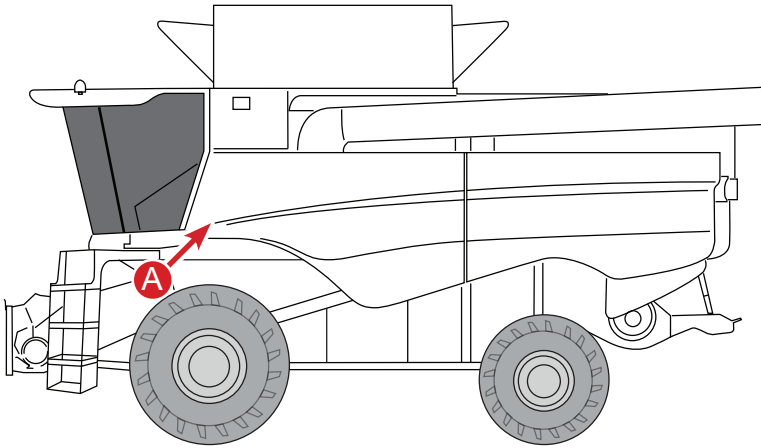

Replace the filter (A) after the first 100 hrs of service, then 400 hr intervals. Replace with John Deere Filter Part No AH128449.

Driveline Maintenance

Standard PTO Style Drive Shafts - These drive shafts utilize a single cross at each end of the drive shafts. Grease zerks on both crosses and the zerk on the outer profile tube (at the slip joint) should be greased on 50-hour intervals.

Constant Velocity Drive Shafts - See the Constant Velocity Driveline Maintenance Guide at the end of this manual. Greasing CV drivelines at the correct time intervals is very important.



Notice

It is important that headers equipped CV drivelines be greased at the appropriate intervals to prevent damage. Warranty will not cover drivelines not properly maintained.

Transition Drive Chain

Tension transition drive chain so there is 1/2 inch deflection at A and B locations. Chain tension is maintained on both the 60-pitch (A) and 80-pitch (B) chains with idler sprockets. Both are located on the right side of the transition.

Check that the sprockets are all in proper alignment. Misalignment of these sprockets will cause premature wear of the sprockets and chain.

Transition Slip Clutch

The transition slip clutch is preset at the factory so that damage will not occur to any of the transition drive components; it cannot be adjusted and will never require any adjustment.

Do not over tighten these sprockets or premature chain and sprocket wear will occur.

In tough conditions if slip clutch is slipping additional grease may be required.

Paddle Beater

The paddle beater has 3 adjustments to where it can be extended or retracted depending on crop conditions. To adjust move paddles to desired slot (C). Make sure both paddles are adjusted to the same slot. In light crop adjust the paddles so they extend all the way out. In heavy crop set them in either the middle or retracted all the way in.

Feeder House Removal

Refer to the John Deere S Series Technical Manual for steps on how to remove and re-install the feeder house.

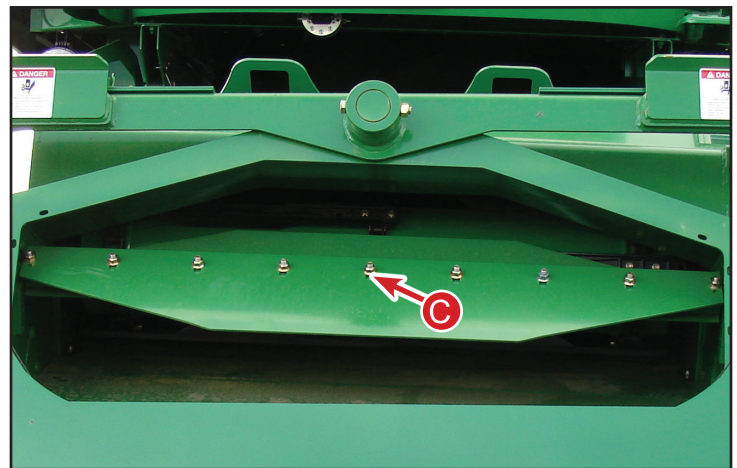
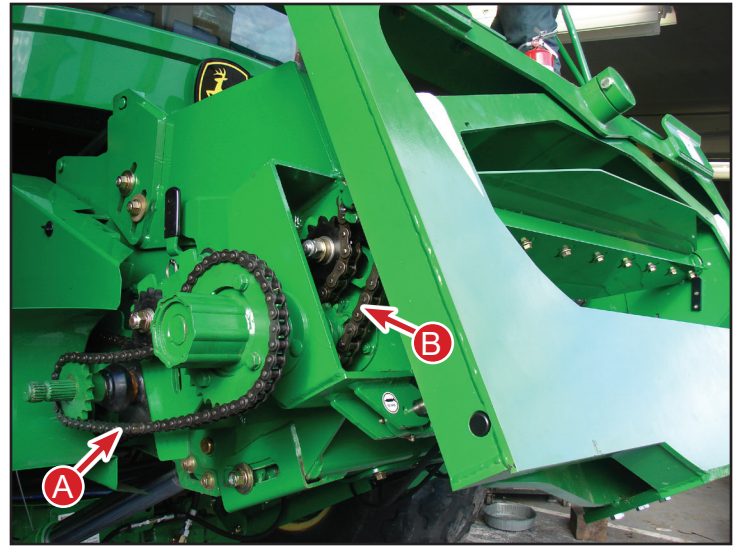

Notice

When removing the feeder house on S680 and S690 combines disconnect the hydraulic lines for the header tilt at the slave cylinder located below the feeder house. Make sure feeder house is properly locked in the up position when disconnecting the hoses. Connect these hoses together if the combine will be leveled without the feeder house. If this is not done and the lines are just capped oil from the master cylinder has no place to go when the combine is leveled and failure will occur.

100 Hour - Annual Maintenance

Inspect the following areas:

REAR AXLE - See pictures on next page for location reference

- All bolts are properly tightened (combine to spacer 235lb-ft and spacer to rear axle are 153 lb-ft)
- Torque rear wheel bolts (150lb-ft + ¼ turn w/RWA, 232lb-ft w/o RWA)
- Steering hoses are properly routed and allow for rear axle rotation

OVERCARRIAGE / UNDERCARRIAGE- See pictures on following pages for location reference

- Torque all mounting bolts properly
- Hydro hoses routed properly
- Brakes are adjusted properly and pedals should depress no more than ½ way
- Brake lines are routed properly, secured and free of pinch and abrasion points

Mounting Bolt Location	Torque
Carriage to Chassis	M16@235lb-ft; M20@450lb-ft
Axle Extensions	675 lb-ft
Final Drive Mounting Bolts	475 lb-ft (oiled)
Transmission Mounting Bolts	235 lb-ft

HYDRAULICS

- Hoses cleanly and securely routed with no pinch or abrasion points
- Hydraulic Reservoir & Main Engine Gear Case are filled to the proper level
- Hydrostatic Hose 4-bolt flange cap screws are tightened to proper torque
- No leaks in the hydraulic system
- Torque gear pump coupler to 130lb-ft
- Hoses by header lift manifold do not come in contact with drive shaft on JH9110

Hose Size	Cap Screws Torque
-16	68lb-ft
-20	111lb-ft

ELECTRICAL

- Harnesses are cleanly and properly routed and secured without pinch or abrasion points
- Mechanical Leveling Stops (bolt on lock collars) are installed so that there is no less than 3/4" clearance around the drive tires.
- Left and right limits are set so that there is no less than 1" clearance around the drive tires.

TRANSITION

- Transition drive chains are properly tightened and sprockets are aligned.
- Feeder chain is properly tension according to JD specification

FUNCTION CHECKS

- Combine responds properly to manual leveling switch (leveling direction matches button)
- Automatic Leveling System responds properly to changes in slope
- Clinometer has been zeroed and the combine returns to level in automatic mode
- Automatic Header Tilt system keeps the transition parallel to ground as the combine levels
- Manual Header Tilt system responds properly to switch and cycle time is set to 22 seconds
- Ladder pivots and locks into place
- Moving step retracts fully and operates smoothly
- Rear Wheels are properly spaced



CAUTION

Failure to conduct these inspections may result in serious damage to the combine, leveling system or could result in injury.

Critical Joint Inspection

The Hillco Leveling System depends on several critical joints integrating the Leveling System to the John Deere combine. These joints require specific torques for safe operation. Operational conditions can over time loosen these joints. Hillco strongly recommends checking these joints annually.

Failure to check these joints annually may result in critical damage to the combine and leveling system.

Please reference the following pages calling out the fasteners holding these critical joints.

Rear Axle

A - Hillco Spacer to John Deere Chassis (4 bolts on MY15-18, 6 bolts MY14 and older) 235 lb-ft

B - Hillco Pin (4 bolts) 235 lb-ft

C - Cast Standoff to Hillco Spacer (4 Bolts) S600 (-78500) 258 lb-ft, S600 (785001-) & S700 236 lb-ft.

D - Cross Bolt (1 Bolt) 152 lb-ft

Note: If any bolts are loose, remove bolt and apply Loctite 242 to threads, install and torque.

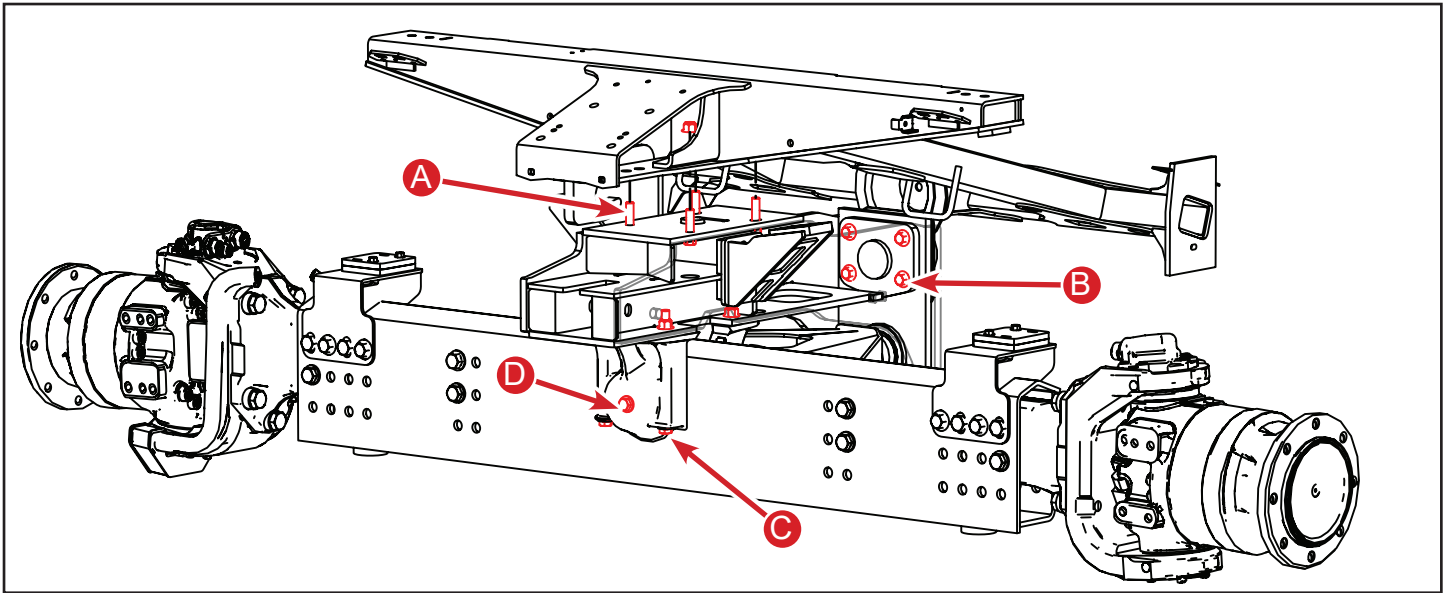

Carriage

A - Final Drives to Hillco Carriage (6 bolts on each side of the combine. Consult Combine's Operators Manual)

B - Carriage to corner post (4 bolts on each side of combine) 235 lb-ft

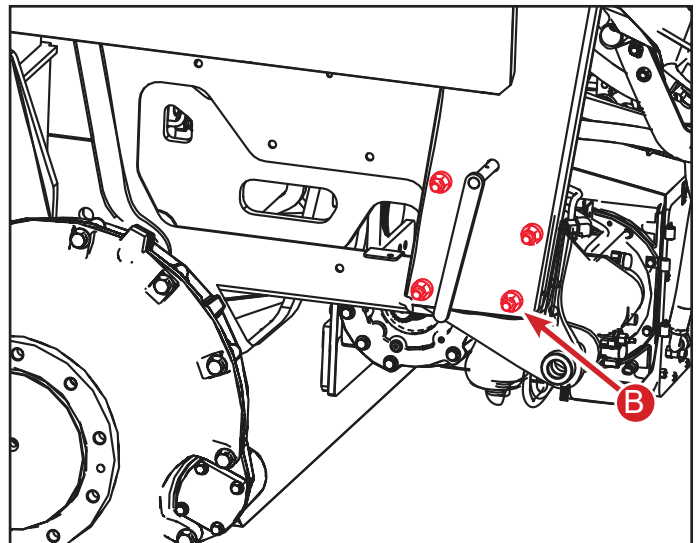
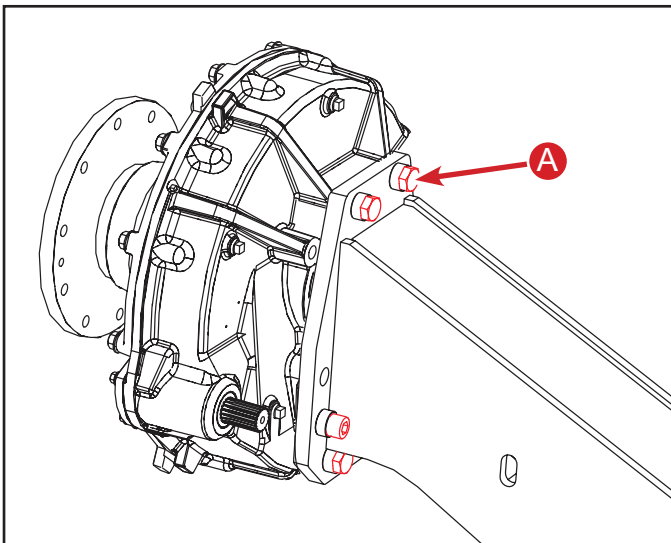

Carriage

A - Axle Straps (2 bolts) 375 lb-ft

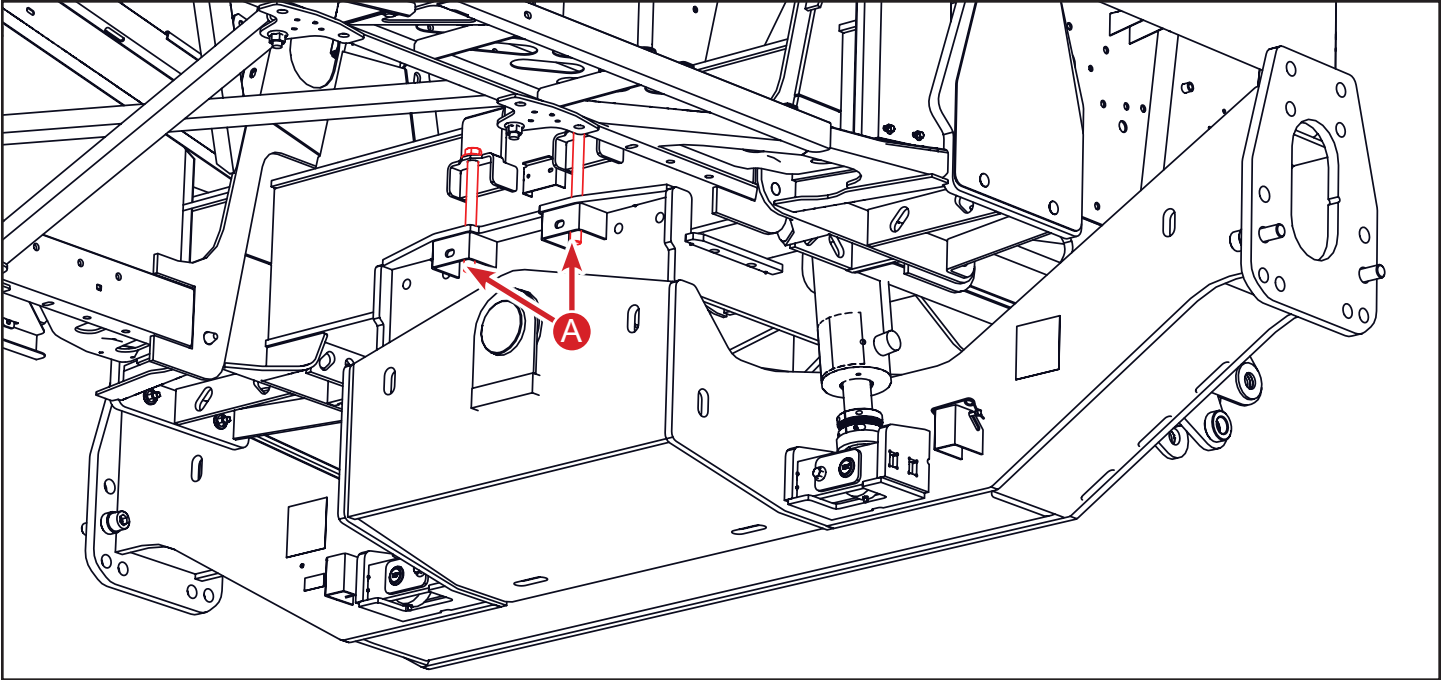

Transition

A - Mounting Bolts (4 bolts) 235 lb-ft

B - Pivot Bolts (2 bolts) 235 lb-ft

C - Bottom Lock Bolts (2 bolts) 460 lb-ft

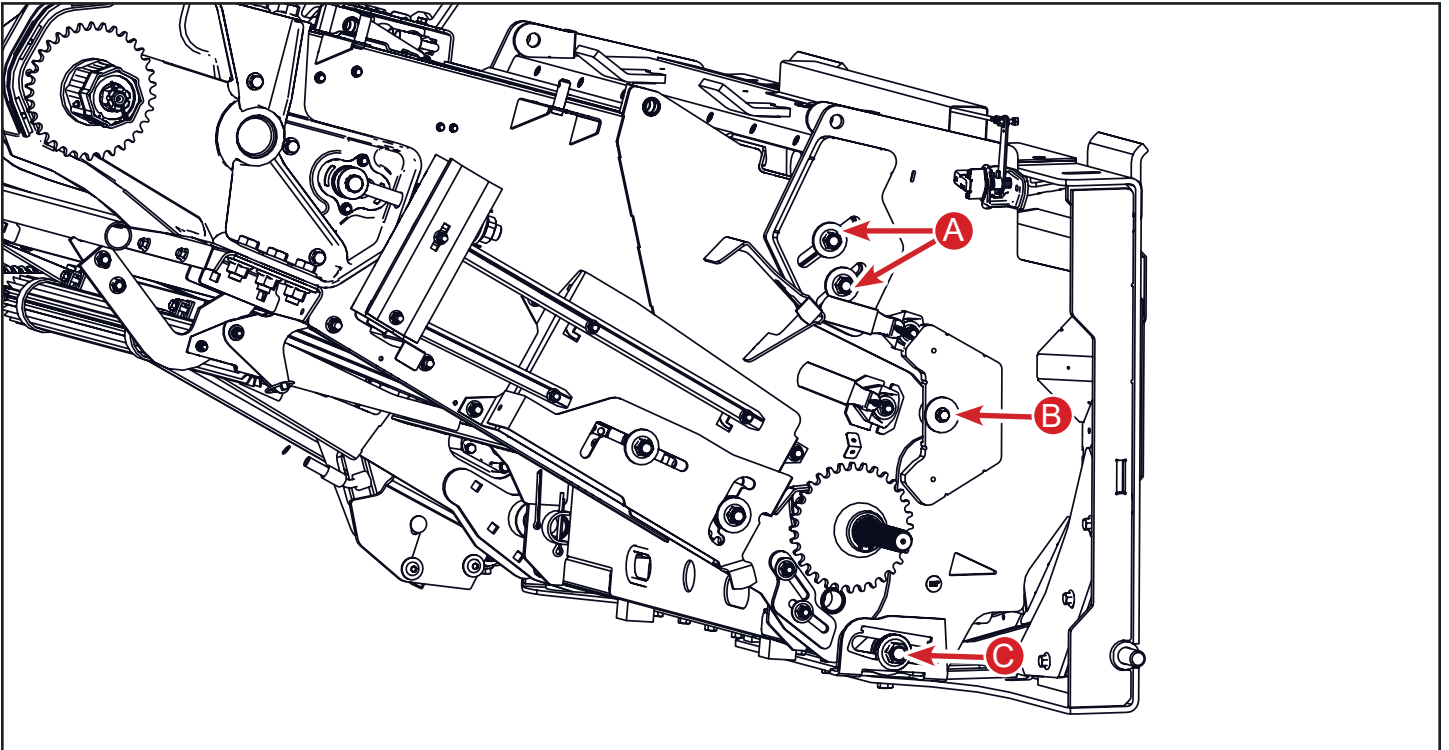

Adjustments

Rear Axle Spacing

On a combine equipped with a Hillco Leveler the rear axle has a greater rotation range. As a result the rear axle spacing must be changed to prevent shield interference. Refer to the diagram below and the following charts for Hillco’s rear axle spacing recommendations. Hillco recommends operating the rear axle in the High Clearance Position on combines equipped with a hillside leveling system.

Rear Axle Position Chart

High Clearance Rear Axle Position

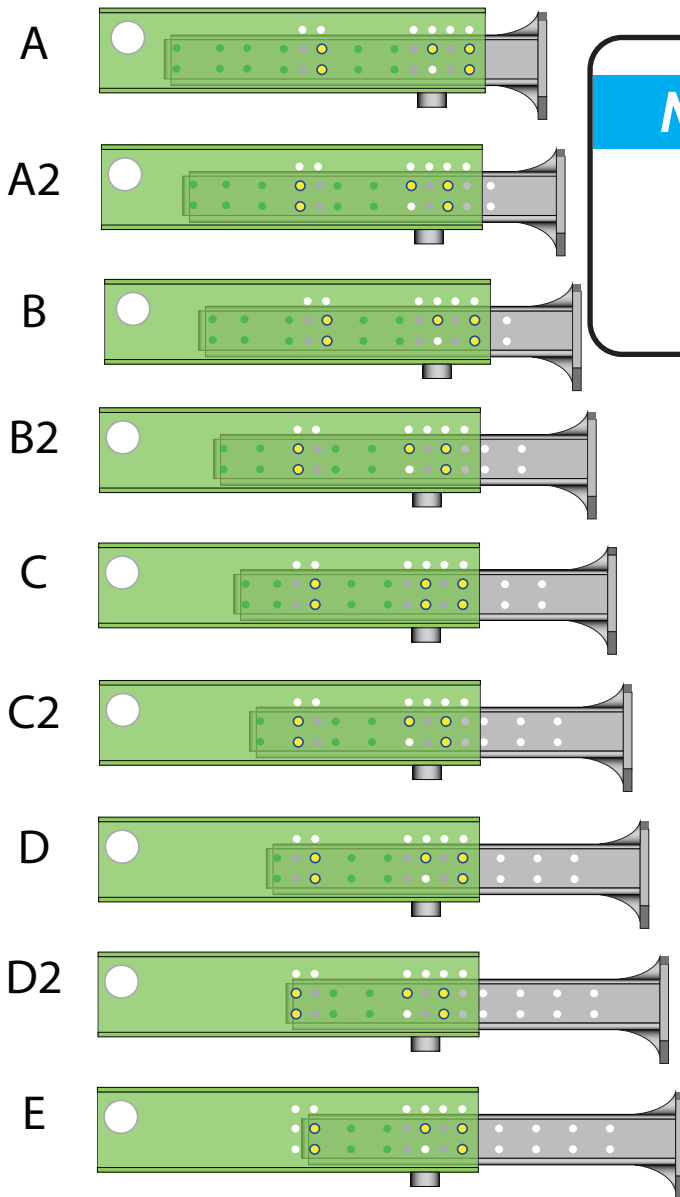

Notice Hillco recommends operating the rear axle in the High Clearance Position on combines equipped with a hillside leveling system. Operating in the Standard Position may cause damage to the gull wing doors.

Extra Heavy Duty Rear Axle Spacing				
Rear Axle Tire	Rear Axle Position	Center to Center (in)	Outside to Outside (in)	Inside to Inside (in)
28L-26 (158A8) R1 or R3	A		Not allowed due to rear shielding interference	
	A2		Not allowed due to rear shielding interference	
	B		Not allowed due to rear shielding interference	
	B2	143.7	174.3	113.2
	C	147.7	178.3	117.2
	C2	151.7	182.3	121.2
	D	155.7	186.3	125.2
	D2	159.7	190.3	129.2
	E	163.7	194.3	133.2

Over Rotation Stop

Hillsides are recommended to run in the High Clearance Position. Depending on axle spacing no rotation stop may be required.

If the rear axle is in the Standard Rear Axle Position an additional stop (A) must be added to the over rotation stop to prevent the tire from coming in contact with the gull wing doors. The additional stop is bolted in place. Hillsides are recommended to run in the High Clearance Position.

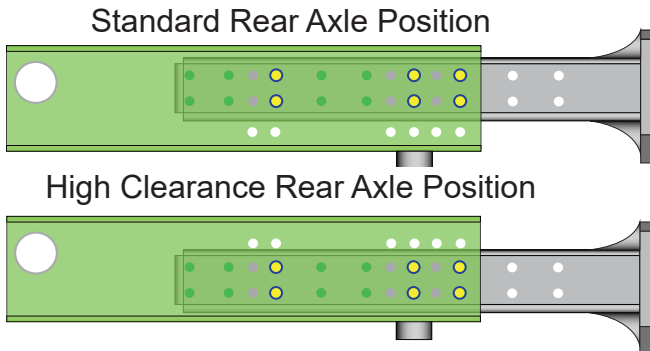

Notice

Make sure the rear tires cannot come in contact with the gull wing doors. Also verify that when the leveling system is maxed out there is still rotation left for the rear axle.

Transition Fore/Aft Adjustment Procedure

1. Loosen the clamping bolts and the pivot bolt on each side of the feeder house.
2. Loosen the jam nuts on the turnbuckles.
3. Loosen the chain tightener on the transition drive chain.
4. Adjust the turnbuckles until the desired header angle is achieved.
5. Tighten the jam nuts.
6. Tighten the clamping and pivot bolts to 153 lb-ft of torque.

Notice

IMPORTANT—Do not adjust the tilt frame with the header on the combine. Shut the engine off, set parking brake and remove key.

Notice

IMPORTANT—Failure to tighten the clamping bolts and pivot bolts to proper torque may cause damage to the turnbuckle mounts.

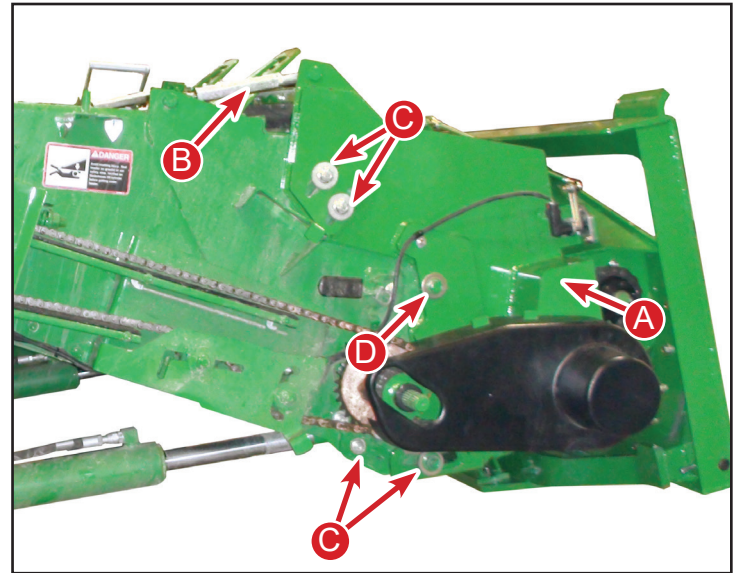

- A - Transition
- B - Turnbuckle
- C - Clamping Bolts
- D - Pivot Bolts

Notice

When adjusting the Fore/Aft tilt be sure to release the tension on the transition drive chain. Failure to release the tension may cause damage to the sprockets or chain.

Lower Feeder Drum Stop Adjustment

The Hillco leveling system does not change the feeder drum stop adjustment. Refer to the John Deere Operator's Manual for your combine for the feeder drum stop adjustment.

Lateral Tilt Flow Control Adjustment

For JH7110 & JH9110 Leveling Systems the lateral tilt flow control valve adjusts the speed at which the header rotates. The header should rotate at the chassis' rotation rate. The tilt speed is a compromise between manual tilt mode and automatic tilt mode. The rotation rate is set at the factory; however with larger header configurations it may be necessary to adjust the header's rotational rate.

To test the header rotation rate, push the tilt button to the left until the tilt frame is rotated to the left limit. Push the tilt button to the right until the tilt frame reaches its right limit. The cycle time should meet the specification of 22 seconds.

Specification

Left-to-Right Cycle Time-22 seconds

If the cycle time is shorter than the specification, turn the flow control set screw (A) clockwise a quarter turn at a time until the cycle time meets the specification. If the cycle time is longer than the specification, turn the flow control screw counterclockwise a quarter turn at a time until the cycle time meets the specification. This specification ensures that tilt speed is adequate for manual operation. With some header configurations this tilt speed may cause the automatic mode to be unstable. Hillco recommends adjusting the Contour Master's sensitivity until it becomes stable. Refer to the combine's operators manual for Contour Master adjustments.

For changing the header tilt speed on a JH9110 Leveling System with factory Contour Master consult the John Deere Operator's Manual.

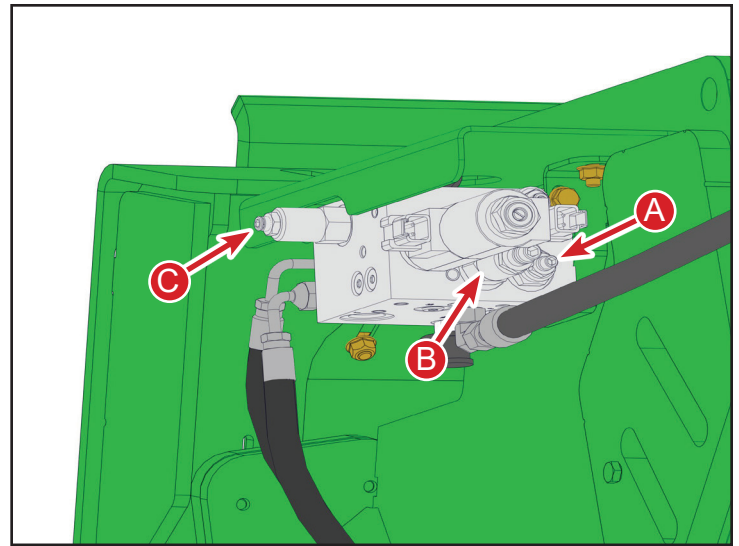

Located on left side of feeder house

A - Flow Control Adjustment

B - Relief Port

C - Counter Balance Valve

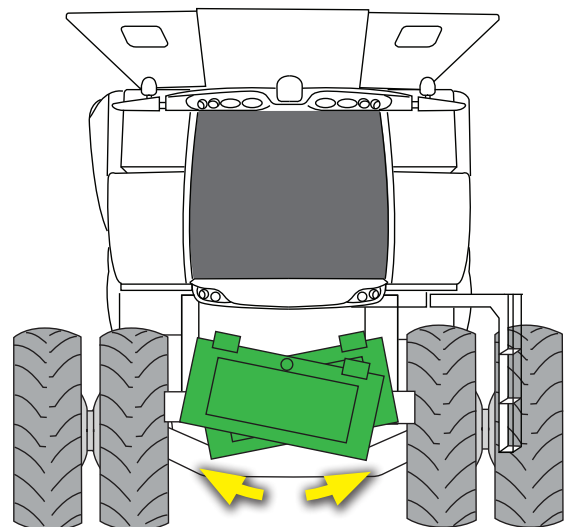

22 second rotation time from one side to other

Notice

The pressure relief valve is pre-set at the factory. Changing the setting may cause damage to the tilt frame or hydraulic system. However, in very large header configurations, it may be necessary to change the setting. Contact your dealer to reset the relief valve.

Mechanical Leveling Cylinder Stops

In the event of electrical controller or hydraulic failure Hillco requires installation of mechanical Leveling Cylinder Stops on combines equipped with oversized drive tires that limit leveling. With certain oversized tires leveling must be limited. The Leveling Cylinder Stops will prevent side panel or tire damage. Contact Hillco for further details.

Stops are available in two thicknesses, 5/8" and 1/8" for adequate adjustment. If additional stops are needed contact Hillco.

See the "Max Level Calibration" section for instructions on how to place the leveling cylinder stops.

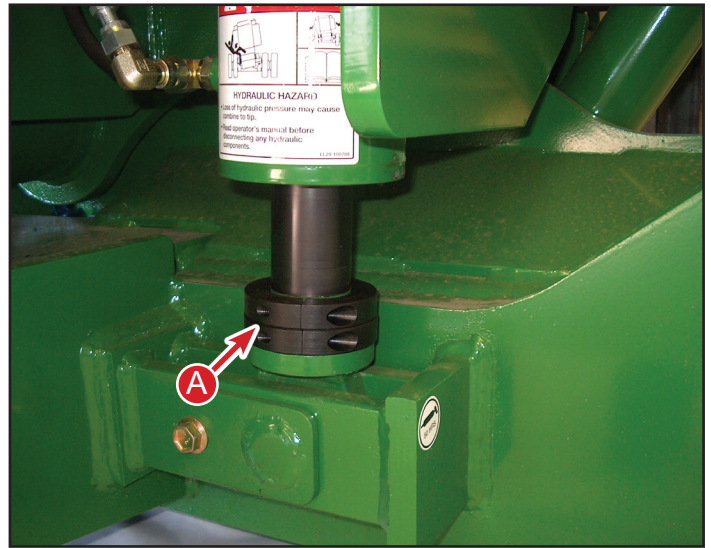

A - Mechanical Leveling Cylinder Stops
(5/8" thick Cylinder Stops Shown)

Notice

In some tire configurations, the tire can contact the gull wing doors or the ladder. In this case, the maximum level must be adjusted to prevent tire contact with the combine chassis. However, to prevent chassis and tire damage in the event of a hydraulic or electrical failure, Hillco strongly recommends that cylinder stops be installed on the leveling cylinders. Hillco is not responsible for chassis damage that occurs due to the lack of appropriate cylinder stops.

Header Tilt Setup

Contour Master functionality should have been turned on during the installation process. If it is not functional follow the below instructions to activate the Contour Master function in the combine's Command Center.

1. Key switch on.

2. Select the Main Menu Icon  in the lower right corner of the "Harvesting" screen.

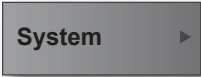
3. Select System Icon 

4. Select Diagnostics Center Icon 

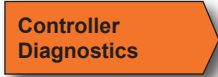
5. Select Controller Diagnostics Icon 

6. Scroll down and select Cab Controller

Cab Controller
CAB.001 | 0x33 | Vehicle

7. Scroll down and select address 111

111 Input 10001000

8. This popup screen will appear. Select the Value (A).

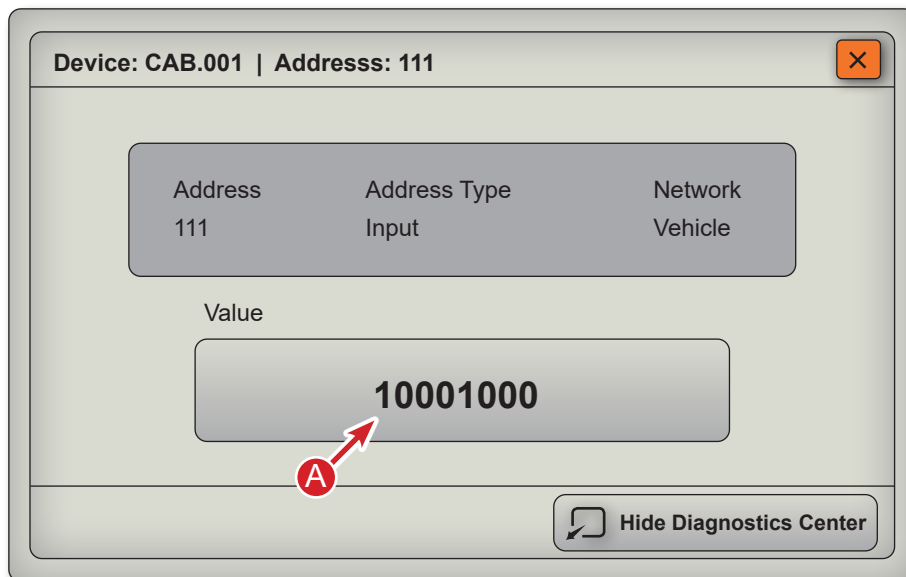

9. Enter the value 10001000 and select OK (A).

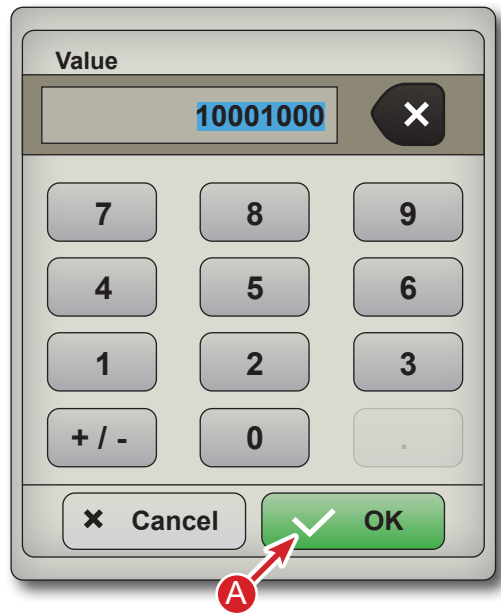

10. You will get a popup that says "Calibration Procedures Problem". Select OK as this will be resolved when calibrated.

Tread Width

The Model JH7110 & JH9110 Leveling Systems are designed around a main undercarriage length of 122.5". With the final drives mounted directly to the 122.5" undercarriage, the tread spacing is 128"-188" which allows for the maximum leveling capability of the combine or 27%.

Tire Selection

Model JH7110 & JH9110 Drive & Steer Tire Assemblies – Combines equipped with the Model JH7110 or JH9110 Leveling System are required to use tires and wheels that meet or exceed Tire & Rim Association standards for Hillside Combine applications. Contact Hillco for more information.

Feeder Adjustment For Tire Size

Adjust the feeder adapter to obtain the proper header angle and cutter bar height as shown in the John Deere® STS Operator's Manual. The chart shown in those manuals will no longer be a correct guide to adjust the feeder adapter due to the height increase created by the leveling system.

Tire Inflation

Tire	Load Index	PSI
Drive (650/75R32) R1 & R3 Tread	175A8	46
Drive (650/65R38) 550 Tread	175A8	46
Steer (28LR-26) R1 & R3 Tread	173A8	36
Steer (28LR-26) 390 Tread	178A8	36
For all other steer tires see the combine's operator's manual for correct pressure		

The Calibration number for the 550 tires is 8450777

All Hillside combines are required to follow the Wheel and Tire Association Standards which states that the tire pressure must be such that the tire has adequate load carrying capability for the maximum possible weight (counting head weight and full grain tank). Both under-inflation and over-inflation are detrimental to tire life. Don't reinflate a tire that has been run flat or when there is obvious or suspected damage to the tire or wheel components. Check the tire pressure weekly or after 50 hours of operation.



WARNING

When inflating tires, use a clip on air chuck and extension hose long enough to allow you to stand to one side and NOT in front or over the tire assembly. Use a safety cage if available.



WARNING

A tire can explode during inflation and cause serious injury or death. Never increase air pressure beyond 35 PSI to seat the bead on the rim. Replace a tire if it has a defect. Replace a wheel rim, which has cracks, wear or severe rust. Make sure that all the air is removed from a tire before removing the tire from the rim. Never use force on an inflated or partially inflated tire. Make sure the tire is correctly seated before inflating.

When first operating the Model JH7110 or JH9110 Leveling System in hillside conditions, begin operation on gradual slopes and work up to more severe slopes only after you have determined that rear axle weighting is appropriate for downhill maneuvers. The first indication of insufficient rear axle weighting is sluggish or unresponsive steering while traveling down hill. This effect will worsen if the operator decelerates. Make sure rear axle weighting is sufficient for safe down hill maneuvers, under normal deceleration, in your most severe down hill conditions.

Notice

Use of grain tank extensions other than those provided by the combine manufacturer is strictly forbidden. Use of such extensions voids both the Hillco and John Deere NEW Equipment Warranties.

Rear Axle Toe In

If the rear tire and wheel size changed after the proper sized rear tires were installed the toe in should be checked. Consult your John Deere combine operator's manual on the correct toe in for your tire and wheel size.

General Shielding

Before operating the combine all shields must be in place and be in working condition. Shield to tire clearance needs to be checked once the correct tires are installed on the combine. Check to see if the clearance is correct by having someone watch the tire and shields as the operator leans the combine to the far right and far left. Some tire selections require limit switches to be set slightly early to allow enough tire clearance between the left and right front side panels.

Drive Shaft and Couplers



DANGER

Worn drive shafts and couplers may fail suddenly leaving the operator without brakes or drive. Check drive shafts and couplers annually for wear.

Rear Axle Weighting

Operator is responsible in determining if combine has proper ballast. If the operator determines that additional weight is needed on the rear axle to ensure optimal down hill performance it can be accomplished by adding:

1. Calcium Chloride in Rear Tires
2. John Deere® Rear Wheel Weights

Use caution when using individual turning brakes. Installation of a Hillco Leveling System transfers additional weight to the rear axle of the combine. Excessive braking to turn can damage your combine chassis.



DANGER

The responsibility for making the final determination of appropriate rear axle weighting lies with the operator.

Hydraulic Settings

Refer to the Hydraulic Safety section for precautions regarding the hydraulic system. The Model JH7110 Leveling System uses an auxiliary gear pump and single-station manifold for its leveling and a separate header trim manifold. The Model JH9110 Leveling System uses hydraulic flow from the closed center hydraulics of the combine. If the combine was not originally equipped with Contour Master then a dual station manifold is installed controlling leveling and header trim. If the combine is equipped with Contour Master then a single station manifold controls the leveling and the John Deere Contour Master manifold controls header tilt. Consult your combine's operator's manual or contact your John Deere dealer for diagnostic and maintenance support regarding the hydraulic system.

Notice

All adjustments on the hydraulic system are preset at the factory for optimal leveling and header trim performance. Do not make any adjustments to these settings without first contacting your authorized Hillco Dealer.

Hydraulic Hoses

Inspect the hydraulic system for leaks, damaged hoses, improper routing, and loose fittings. Hydraulic hoses that are not routed correctly could become worn from working against abrasive edges or moving parts. If abrasions or holes do occur, the hydraulic hoses can only be replaced, not repaired. Do not attempt repairs with tape or cements. High pressure will burst such repairs and cause system failure and possible injury.

Hydraulic Hose Connections – When tightening loose hoses on the cylinders, pump, etc., always use one wrench to keep the hose from twisting and another wrench to tighten the union. Excessive twisting will shorten hose life and allow the fitting to loosen during operation. Do not over-tighten fittings or adapters.

Refer to the John Deere® Combine's Operators Manual for information regarding hydraulic oil, check intervals, and reservoir fluid levels. High speed leveling, low speed leveling and header trim speeds are preset at the factory. If different speeds are desired please contact your Hillco dealer.

Hydraulic Cylinder

Notice

Each leveling cylinder is equipped with a safety valve (counterbalance valve) that is in place to prevent unintentional leak down of the cylinder. These safety valves are preset at the factory, and should not be adjusted.



WARNING

Do not make any repairs to the cylinders, disconnect valves, or disconnect any hoses connected to the cylinders, counterbalance valves, bulkhead mount or manifold without first contacting your authorized Hillco dealer. These hydraulic components stabilize the chassis of the combine. Improper repair or replacement of these components could lead to uncontrolled leveling of the combine's chassis. The leveling cylinder safety stops can be used to prevent accidental tipping of the combine during repair.

Header Compatibility Chart

To determine if a header kit is required or available for a specific leveling system model match the appropriate header with the corresponding leveling system model to determine availability. Contact Hillco for pricing as well as header kit availability for any John Deere header not listed below. Operator is responsible for ensuring that combine has proper ballast.		Hillco Leveling System Model			
		2975H Hillside	JH7110 Hillside	JH9110 Hillside	2965H Hillside
Max Header Weight		9,400 lbs.	9,500 lbs	9,500 lbs	6,500 lbs
PICKUP HEADS	615	Yes	Yes	Yes	N/A
	914	Yes	Yes	Yes	N/A
Platforms Rigid / Flex	618	N/A	N/A	N/A	N/A
	620	N/A	N/A	N/A	N/A
	622	Yes	Yes	Yes	N/A
	630	Yes	Yes	Yes	N/A
	635	Yes	Yes	Yes	N/A
	920 Early S/N	N/A	N/A	N/A	N/A
	920 Late S/N	N/A	N/A	N/A	N/A
	922 Early S/N	N/A	N/A	N/A	N/A
	922 Late S/N	N/A	N/A	N/A	N/A
	925 Early S/N	Yes	Yes	Yes	Yes
	925 Late S/N	Yes	Yes	Yes	Yes
	930 Early S/N	Yes	Yes	Yes	Yes
930 Late S/N	Yes	Yes	Yes	Yes	
Draper Heads	625D	Yes	Yes	Yes	N/A
	630D	N/A	N/A	N/A	N/A
	635D	Yes	Yes	Yes	N/A
	925D	Yes	Yes	Yes	N/A
	930D	Yes	Yes	Yes	N/A
	936D	Yes	Yes	Yes	N/A
Flex Draper Heads	630FD w/o top auger	N/A	Yes	Yes	N/A
	630FD w/ top auger	N/A	Yes	Yes	N/A
	635FD w/o top auger	N/A	Yes	Yes	N/A
	635FD w/ top auger	N/A	Yes	Yes	N/A
	640FD w/o top auger	N/A	Yes	Yes	N/A
	640FD w/ top auger	N/A	Yes	Yes	N/A
	645FD w/o top auger	N/A	Call Hillco	Call Hillco	N/A
	645FD w/ top auger	N/A	Call Hillco	Call Hillco	N/A
	MacDon D60/FD70 (30', 35', 40')	Yes	Yes	Yes	N/A
	MacDon D65/FD75 (30', 35', 40', 45')	Yes	Yes	Yes	N/A
	MacDon D1/FD1 (30', 35', 40', 45')	Yes	Yes	Yes	N/A
	MacDon D2/FD2 (30', 35', 40', 45')	Yes	Yes	Yes	N/A
	700 Series FD	Call Hillco	Call Hillco	Call Hillco	N/A
John Deere HDR/HDF	N/A	Yes	Yes	N/A	

Leveling System Specifications

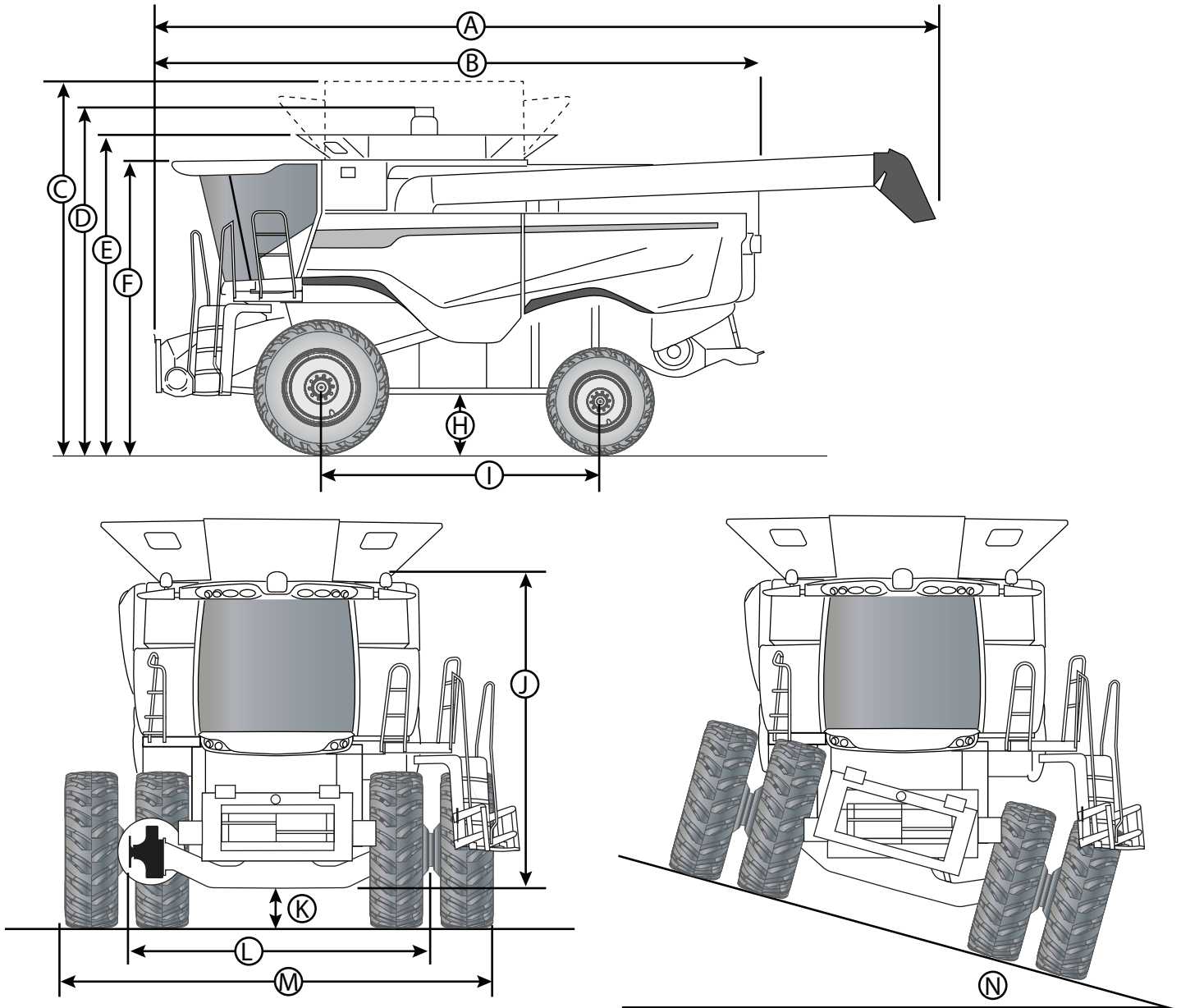

NOTE: Dimensions are approximate and subject to change without notice.

Dimension Reference Points are on the previous page.

Dimension	JH9110	JH7110
	650/65R38 Front Tires 28LR26 Rear Tires 26' unloading auger	650/65R38 Front Tires 28LR26 Rear Tires 26' unloading auger
John Deere Models	S7 800 & S7 900	S7 600 & S7 700
A	Beaterless 39 ft - Paddle Beater 39 ft 9 in	Beaterless 39 ft - Paddle Beater 39 ft 9 in
B	Beaterless 29 ft; Paddle Beater 29 ft 9 in	Beaterless 29 ft; Paddle Beater 29 ft 9 in
C	16 ft 7in 300 bu/tank - 17 ft 400 bu/tank	16 ft 7in 300 bu/tank - 17 ft 400 bu/tank
D	16 ft 300 bu/tank - 16 ft 6 in 400 bu/tank	16 ft 300 bu/tank - 16 ft 6 in 400 bu/tank
E	15 ft 300 bu/tank - 15 ft 11 in 400 bu/tank	15 ft 300 bu/tank - 15 ft 11 in 400 bu/tank
F	13 ft 8 in	13 ft 8 in
G	12 ft 10 in	12 ft 10 in
H	1 ft 11 in	1 ft 11 in
I	12 ft 9 in	12 ft 9 in
J	11 ft 8.5 in	11 ft 8.5 in
K	12 in	12 in
L	158 in	158 in
M	212.5 in (17' 7 in)	212.5 in (17' 7 in)
N	27% (15.4°)	27% (15.4°)
Leveling Controller	Clinometer (Accuracy +/- 3/4°)	
Leveling Speed	Proportional Control with Auto / Manual	
Leveling Hydraulic System	Integrated into Combine's Closed Center Hydraulics	Gear Pump
Header Lateral Tilt Control	Hydraulic Master / Slave Cylinder w/ Auto/Manual Override	
Feeder Transition	Paddle Beater/Beaterless	
Weight added to combine	4,100 lbs	4,100 lbs

JS7020, JS9020, JH7020 & JH9020 Electrical Leveling Schematic
SN (22001-22999)

X006 - Sensor Package			To	
Pin	Wire Color	Description	Connector	Pin
1	Red	Carriage Sensor Power	X048	3
2	Black	Carriage Sensor Ground	X048	1
3	Orange	Carriage Sensor Signal	X048	2
4	Red	Clinometer Power	X046	1
5	Black	Clinometer Ground	X046	2
6	Green	Clinometer F/A Signal	X046	4
7	Blue	Clinometer L/R Signal	X046	3
8	-	-	-	-
9	-	-	-	-
10	-	-	-	-
11	-	-	-	-
12	-	-	-	-

X046 - Clinometer MPC			To	
Pin	Wire Color	Description	Connector	Pin
1	Red	Clinometer Power	X006	4
2	Black	Clinometer Ground	X006	5
3	Blue	Clinometer L/R Signal	X006	7
4	Green	Clinometer F/A Signal	X006	6

X046 - OC Position Sensor			To	
Pin	Wire Color	Description	Connector	Pin
1	Black	Carriage Sensor Ground	X006	2
2	Orange	Carriage Sensor Signal	X006	3
3	Red	Carriage Sensor Power	X006	1
4	-	-	-	-
5	-	-	-	-
6	-	-	-	-

X101 - Sensor Power/Ground Bus			To	
Pin	Wire Color	Description	Connector	Pin
1	Red	Sensor Power Supply	X106	8
2	Red	Joystick Power	X203	3
3	Black	Sensor Ground Supply	X106	9
4	Black	Joystick Ground	X203	4
5	Black	UC Sensor Ground	X200	2
6	-	-	-	-
7	-	-	-	-
8	Red	UC Sensor Power	X200	1

X104 - Ground Bus			To	
Pin	Wire Color	Description	Connector	Pin
1	Black	Ground Bus	X203	2
2	Black	Controller Ground	X106	1
3	Black	Clinometer Ground	X200	4
4	Black	Left Valve Ground	X202	2
5	Black	Right Valve Ground	X201	2
6	Black	Auto Switch Ground	X203	6
7	-	-	-	-
8	-	-	-	-

X105 - Controller B Black Connector			To	
Pin	Wire Color	Description	Connector	Pin
1	Green	Joystick Signal	X203	5
2	-	-	-	-
3	White	Left Valve Power	X202	1
4	Green	Right Valve Power	X201	1
5	-	-	-	-
6	-	-	-	-
7	-	-	-	-
8	-	-	-	-
9	-	-	-	-
10	-	-	-	-
11	-	-	-	-
12	Red	Clinometer Power	X200	4

X106 - Controller A Grey Connector			To	
Pin	Wire Color	Description	Connector	Pin
1	Black	Clinometer Ground	X104	2
2	Orange	Controller Power	X203	1
3	Yellow	CAN High	X203	8
4	Green	CAN Low	X203	9
5	-	-	-	-
6	White	Auto Switch Signal	X203	7
7	-	-	-	-
8	Red	Sensor Power Supply	X101	1
9	Black	Sensor Ground Supply	X101	3
10	Blue	Clinometer Left/Right Signal	X200	7
11	Green	Clinometer Fore/Aft Signal	X200	6
12	Orange	UC Sensor Signal	X200	3

JS7020, JS9020, JH7020 & JH9020 Electrical Leveling Schematic
SN (22001-22999)

X200 - Sensor Package			To	
Pin	Wire Color	Description	Connector	Pin
1	Red	UC Sensor Power	X101	8
2	Black	UC Sensor Ground	X101	5
3	Orange	UC Sensor Signal	X106	12
4	Red	Clinometer Power	X105	12
5	Black	Clinometer Ground	X104	3
6	Green	Clinometer F/A Signal	X106	11
7	Blue	Clinometer L/R Signal	X106	10

X201 - Right Valve			To	
Pin	Wire Color	Description	Connector	Pin
1	Green	Right Valve Power	X105	4
2	Black	Right Valve Ground	X104	5

X202 - Left Valve			To	
Pin	Wire Color	Description	Connector	Pin
1	White	Left Valve Power	X105	3
2	Black	Left Valve Ground	X104	4

X203 - Cab Bulkhead			To	
Pin	Wire Color	Description	Connector	Pin
A	Orange	Controller Power	X106	2
B	Black	Controller Ground	X104	1
C	Red	Joystick Power	X101	2
D	Black	Joystick Ground	X101	4
E	Green	Joystick Signal	X105	1
F	Black	Auto Switch Ground	X104	6
G	White	Auto Switch Signal	X106	6
H	Yellow	CAN High	X106	3
J	Green	CAN Low	X106	4

X300 - Cab Bulkhead			To	
Pin	Wire Color	Description	Connector	Pin
A	Orange	Key Power	X310	C
B	Black	Controller Ground	X311	3
C	Red	Joystick Power	X302	1
D	Black	Joystick Ground	X302	2
E	Green	Joystick Signal	X302	3
F	Black	Auto Switch Ground	X302	5
G	White	Auto Switch Signal	X302	4
H	Yellow	CAN High	X304	7
J	Green	CAN Low	X304	8

X301 Diagnostic MPC				To	
Pin	Wire Color	Description	Connector	Pin	Pin
A	-	-	-	-	-
B	-	-	-	-	-
C	Yellow	CAN1 High	X303	7	7
D	Green	CAN1 Low	X303	8	8
E	-	-	-	-	-
F	-	-	-	-	-
G	-	-	-	-	-
H	-	-	-	-	-
J	-	-	-	-	-

X302 - Switch Box				To	
Pin	Wire Color	Description	Connector	Pin	Pin
1	Red	Joystick Power	X300	C	C
2	Black	Joystick Ground	X300	D	D
3	Green	Joystick Signal	X300	E	E
4	White	Auto Switch Signal	X300	G	G
5	Black	Auto Switch Ground	X300	F	F
6	Black	Alarm Ground	X304	12	12

JS7020, JS9020, JH7020 & JH9020 Electrical Leveling Schematic
SN (22001-22999)

X304 - Display A			To	
Pin	Wire Color	Description	Connector	Pin
1	Black	Display Ground	X310	H
2	Orange	Display Ground	J2	
3	Yellow	Can0 High	X310	F
			RE67013	C
4	Green	Can0 Low	X300	H
5	-	-	-	-
6	-	-	-	-
7				
8	Yellow	Can1 High	X301	C
9	Green	Can1 Low	X301	D
10				
11				
12	Black	Alarm Ground	X302	6

X309 - CAN Tee			To	
Pin	Wire Color	Description	Connector	Pin
1	Yellow	CAN O High Tee	X300	H
			X304	7
2	Green	CAN O Low Tee	X300	J
			X304	8

Yellow wire tees with legs going to X300 pin H and X304 Pin 7. Green wire tees with legs going to X300 pin J and X304 Pin 8.

X310 - Power Distribution Tee			To	
Pin	Wire Color	Description	Connector	Pin
A	Black	Relay Ground	X311	4
B	-	-	-	-
C	Orange	Controller Power	X300	A
D	-	-	-	-
E	-	-	-	-
F	Orange	Keyed Power	RE67013	C
G	-	-	-	-
H	Red	Battery Power	RE67013	A

X311 - Cab Ground Bus				To	
Pin	Wire Color	Description	Connector	Pin	
1	Black	Ground	RE37013	B	
2	Black	Display Ground	X304	2	
3	Black	Controller Ground	X300	B	
4	Black	Relay Ground	X310	A	

RE67013 - John Deere Powerstrip Connector				To	
Pin	Wire Color	Description	Connector	Pin	
A	Red	Power	X310	H	
B	Black	Ground	311	1	
C	Orange	Key Power	X310	F	
			X304	3	

X400 - Auto Switch Signal			To	
Pin	Wire Color	Description	Connector	Pin
1	White	Auto Switch Signal	X401	4

X401 - Switch Box			To	
Pin	Wire Color	Description	Connector	Pin
1	Yellow	Joystick Power	Joystick Pigtail	
2	Blue	Joystick Ground		
3	Green	Joystick Signal		
4	White	Auto Switch Signal	400	1
5	Black	Auto Switch Ground	402	1
6	-	-	-	-

X402 - Auto Switch Ground			To	
Pin	Wire Color	Description	Connector	Pin
1	Black	Auto Switch Ground	X401	5

JS9110 & JH9110 Header Trim Electrical Schematic
 SN 25001-25999
 For Combines Equipped with Hillco Header Tilt Valve

WIRING HARNESS 1320731

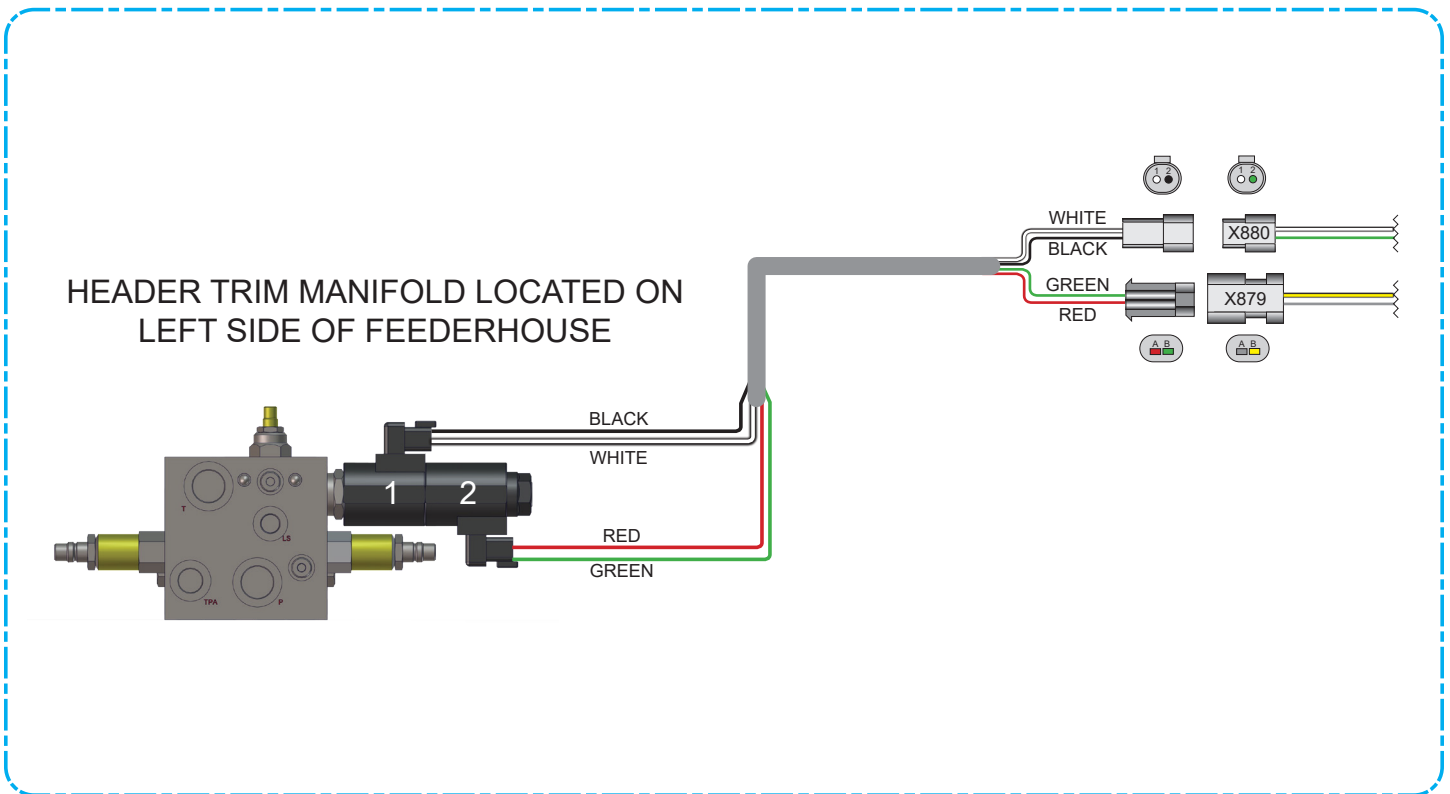

JOHN DEERE PLUG X879
 LOCATION: Left side of Feederhouse

PIN	COLOR	FUNCTION	To
1	WHITE	Trim Left Power	Coil #1 Pin 1
2	BLACK	Trim Left Ground	Coil #1 Pin 2

JOHN DEERE PLUG X880
 LOCATION: Left side of Feederhouse

PIN	COLOR	FUNCTION	To
A	RED	Trim Right Ground	Coil #2 Pin 1
B	GREEN	Trim Right Power	Coil #2 Pin 2

JS9110 & JH9110 Hydraulic Circuit Schematic

For John Deere S7 800 & S7 900 Combines with Contour Master

HILLCO Serial Number 25001 thru 25999

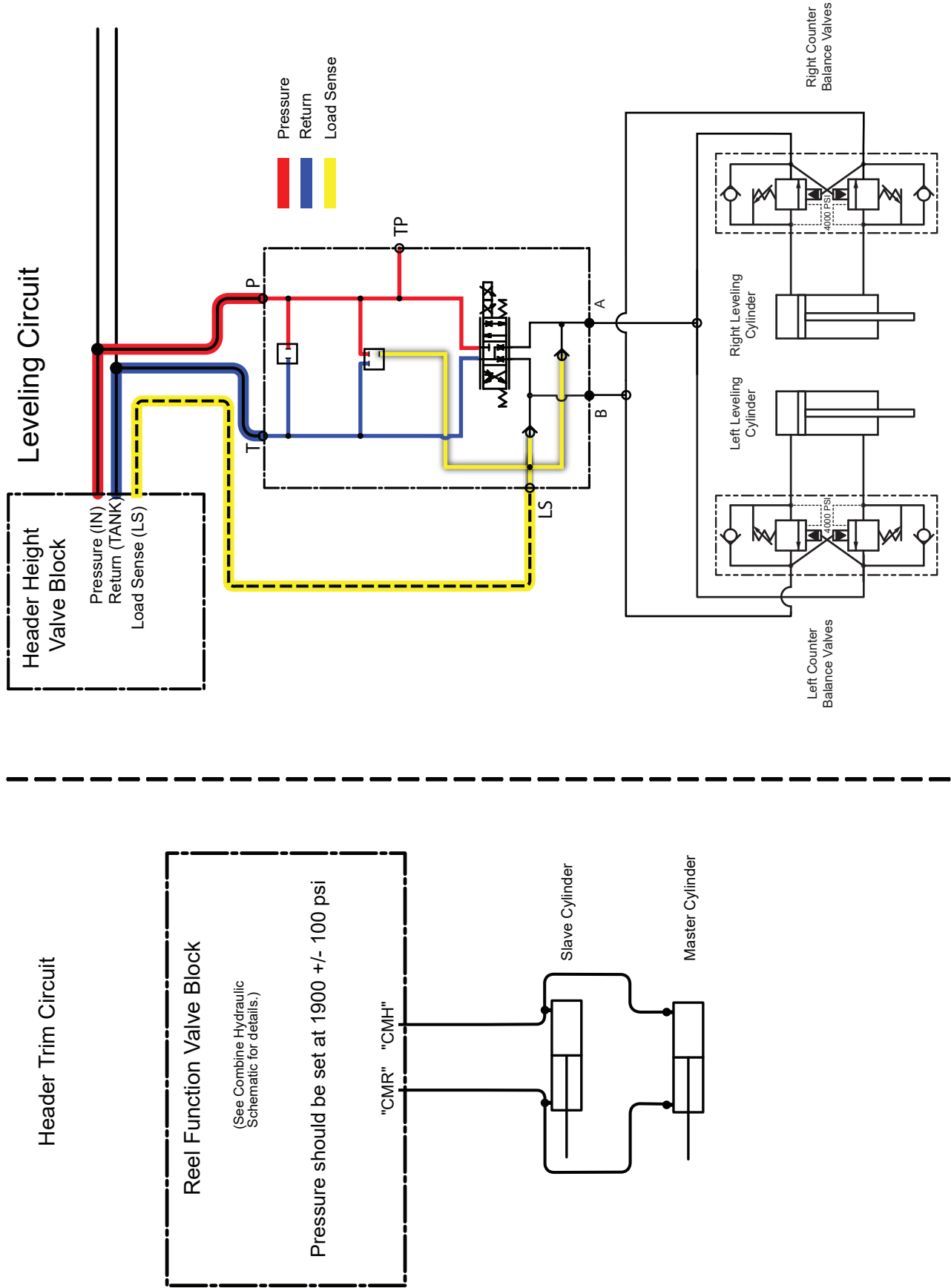

JS9110 & JH9110 Hydraulic Circuit Schematic

For John Deere S7 800 & S7 900 Combines with Hillco Lateral Tilt Valve
 HILLCO Serial Number 25001 thru 25999

Leveling Circuit

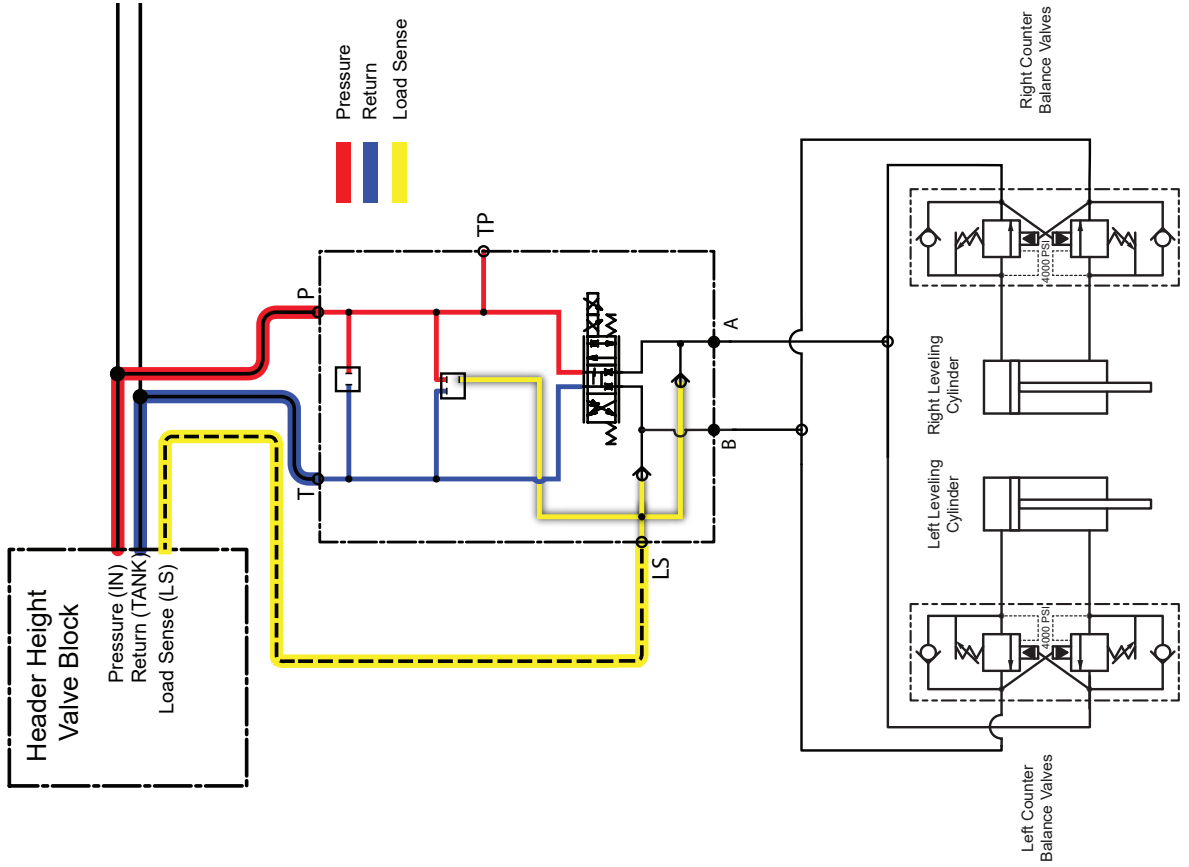

Header Trim Circuit

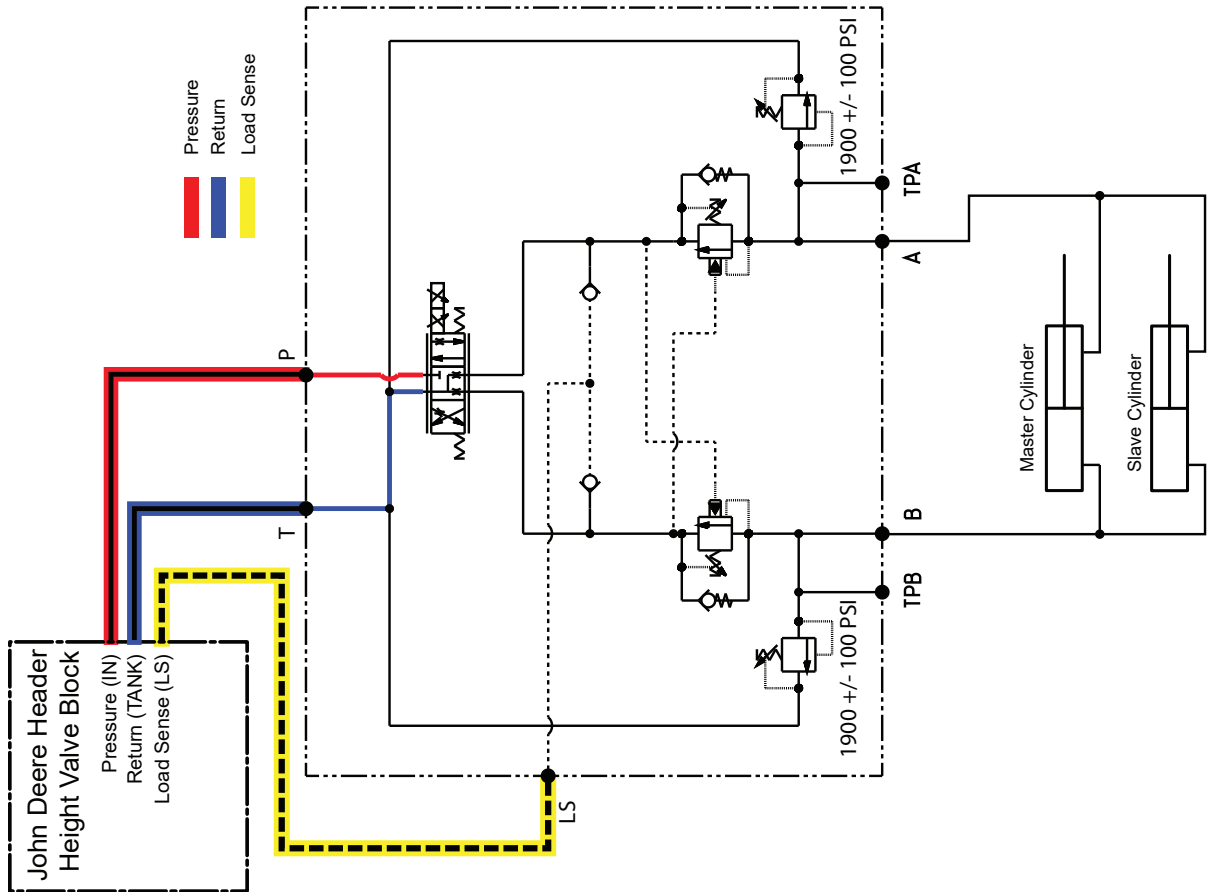

JS7110 & JH7110 Standard (Gear Pump) Hydraulic Circuit Schematic

For John Deere S7 600 & S7 700 Combines
Hillco Serial Number 25001-25999

Header Trim Circuit

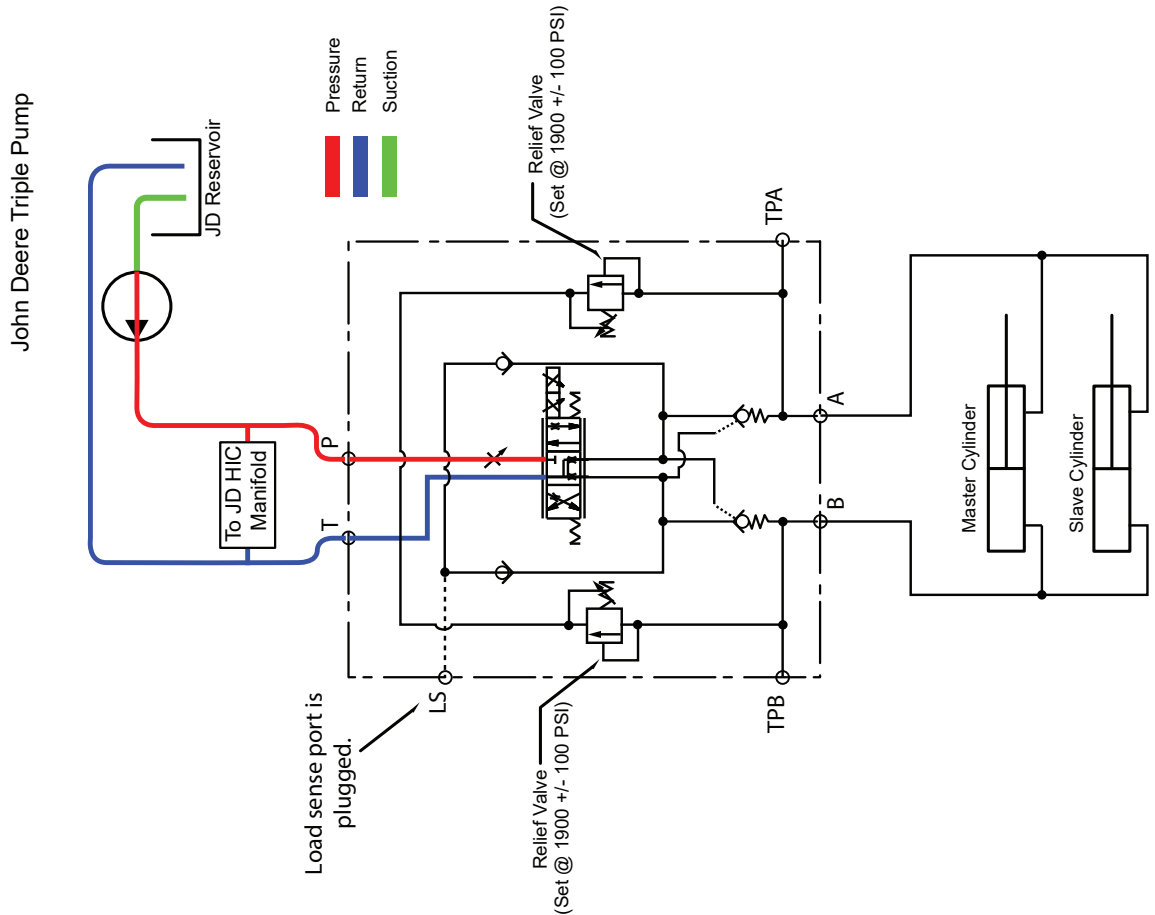

Leveling Circuit

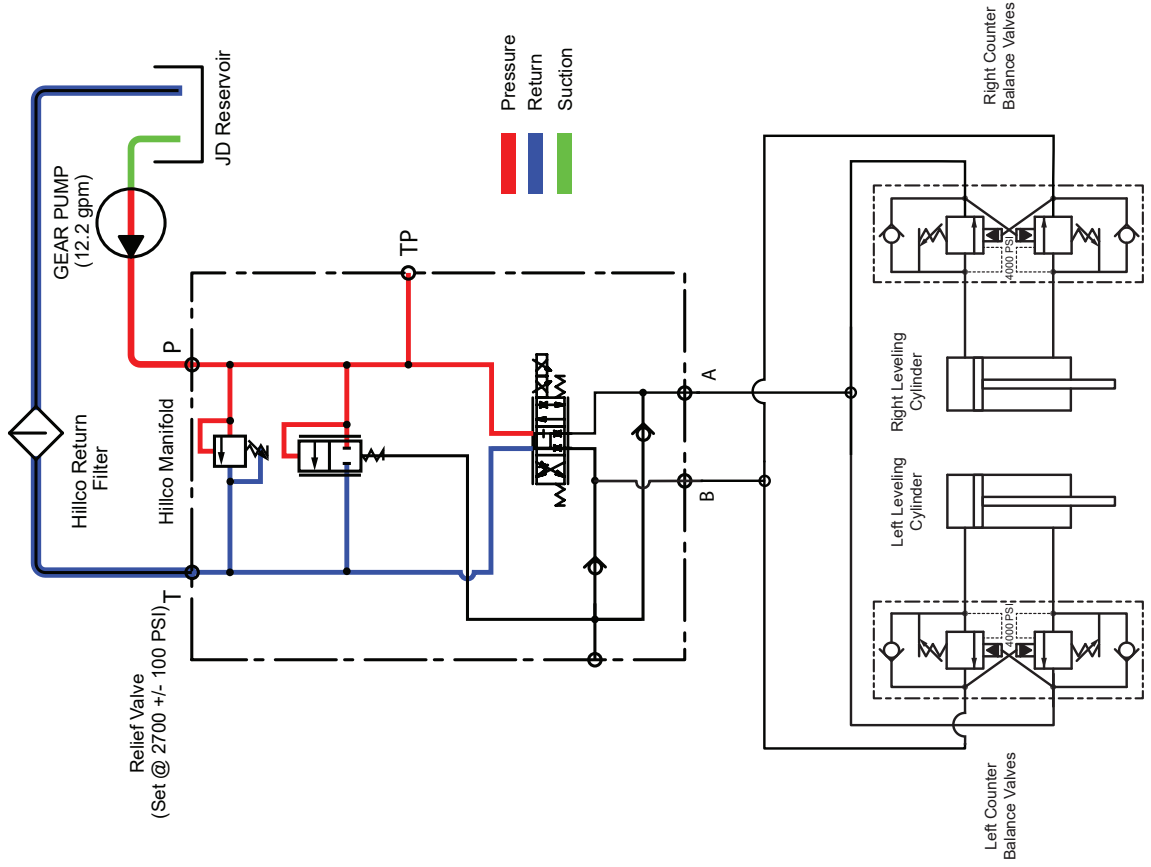

IMPORTANT!

PWE LUBE REQUIREMENTS

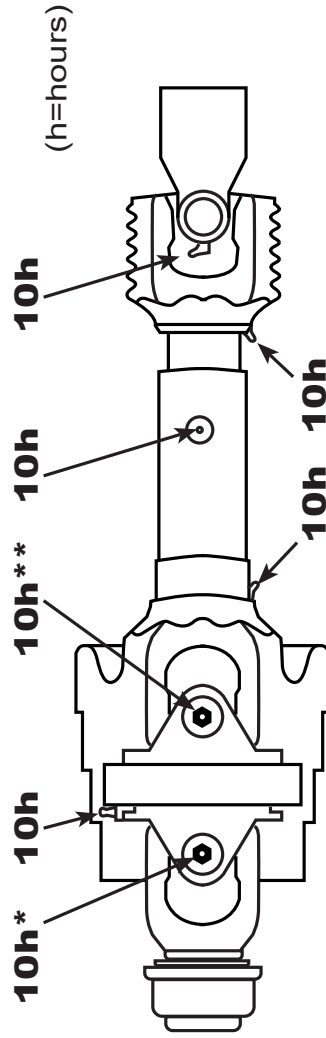

* lubricate outer cross kit with about 5 pumps of grease (about 15 grams).

** Inner cross kit also lubricates the double yoke. Lubricate with about 15 pumps of grease (about 45 grams). Consult operator's manual for additional information.

Leave this manual attached to the driveline so the end user can see the Driveline Maintenance Guide.

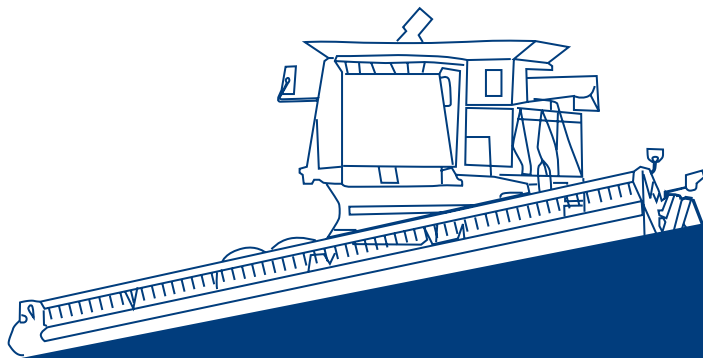

80 Degree Walterscheid Driveline Maintenance Guide

D-160831CMA01
August, 2016

Background

We are often asked about the frequency and type of grease to use when servicing drivelines. We believe a frequent and thorough greasing is more important than the type of grease you use. Dirt and grease make an excellent grinding compound; a proper greasing cleans out any contaminants. While greasing, pump grease until you see clean grease come out past all of the seals, this insures that debris is flushed out. Unlike most bearing seals, drivelines cannot be over greased as the seals are designed to let grease flow through. The initial greasing will take more grease pumps to purge the assemblies; after that, regular maintenance scheduling is required. Lack of proper lubrication is the most common cause of universal joint, center housings, and slip joint problems. Hillco works closely with driveline manufacturers to develop drivelines rated for the thrust load and angle demands of each different header. Properly sized center housings, universal joints, and slip joints, maintained at recommended intervals, will meet or exceed operation requirements. Inadequate lubrication is the leading cause of driveline failure. Failure to follow lubrication instructions for one interval may lead to total failure of the driveline. Inspecting and servicing your driveline on a scheduled, twice daily basis the first few days of service will help you develop a feel for your maintenance needs.

Lubricate all grease zerks with a high quality, lithium soap compatible, EP grease meeting the N.L.G.I. #2 specifications and containing no more than 1% molybdenum disulfide.

Zerk Location	Service Interval	Grease Gun Lever Action Pumps
Inner Cross, CV Balls & Sockets	10 hrs.	15
Telescoping Members	10 hrs.	2-3
Outer Crosses	10 hrs.	5
Shielding Bushings	10 hrs.	5

Notice

New drivelines and replacement parts are not lubricated. New drivelines and replacement parts must be lubricated at the time of assembly and during use per recommendations

Notice

Drivelines not properly maintained will not be covered by warranty.

Zerk Locations

1. Outer Cross (2 zerks) - Zerk is on caps it is necessary to only grease one cap.
2. Inner Cross, CV Ball and Socket (2 zerks) - Zerk is on caps it is necessary to only grease one cap.
3. Telescoping Members (1 zerk)
4. Stationary Shield Bushing (2 zerks)

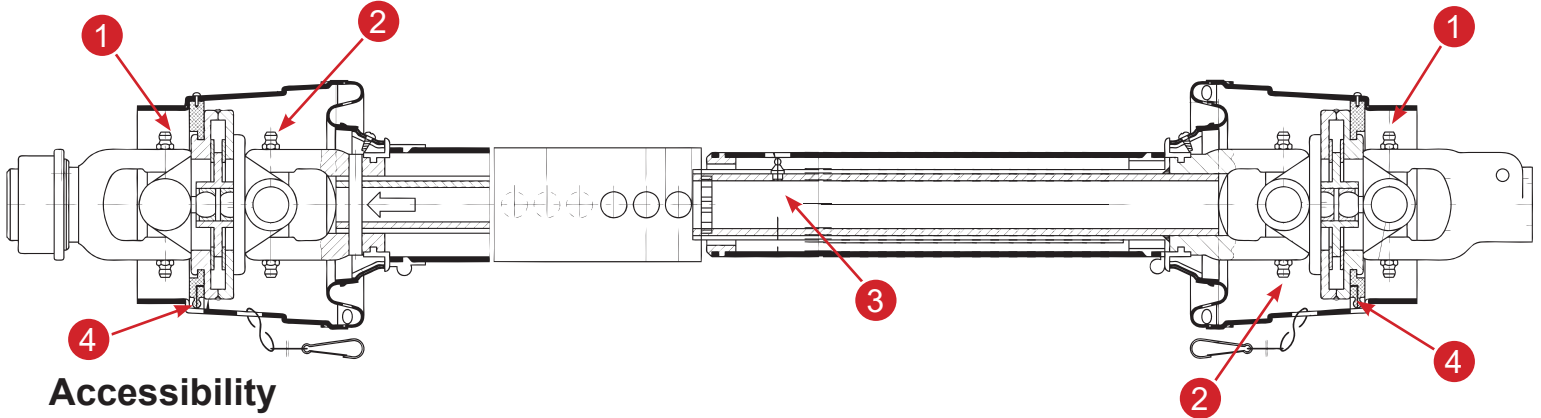

Accessibility

Each constant velocity driveline has at least 5 grease zerks (drivelines that have a stationary shield have at least 7 zerks). Due to various header/combine combinations some zerks may be inaccessible. Cutting a new hole in the profile shield is mandatory to access these zerks. Locate all zerks in your C.V. driveline and make sure there is access to properly grease each one. If the access hole is covered up due to the position of the driveline a new hole will need to be cut.

Driveline Removal - Only for Driveline Part No 155310

If the driveline is to be removed from the gear case input shaft, follow these steps:

Loosen the nut approximately ½ turn (A)

Insert a punch into the hole on the opposite side and tap with a hammer to loosen

Finish removing the retaining bolt.

If this procedure is not followed, the retaining bolt may break while removing.

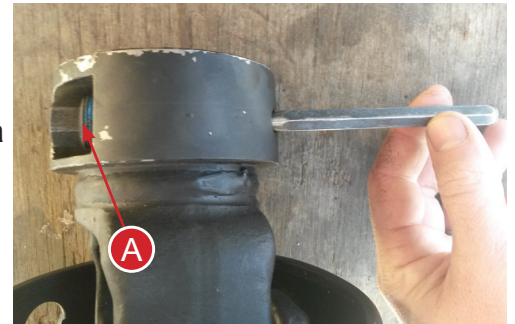

Decal Placement

