

# Operators Manual & Parts Book



## Model WTR410

## Model WTR510

### Wrap Twine Remover

Patent Pending

D-250113DMC01A

	 <b>WARNING</b>
	<p>Read and understand the operator's manual prior to operating this equipment.</p> <p>Failure to follow operation instructions could result in personal injury or damage to the equipment.</p>

Hillco Technologies, Inc. 1010 1st Ave. Nezperce, Idaho  
Phone: 800.937.2461  
[www.hillcotechnologies.com](http://www.hillcotechnologies.com)

# Table of Contents

<b>General Information</b>	<b>3</b>
Serial Number Location	3
Text and Illustrations	3
Abbreviations	3
Right and left Identification	3
Part Orders	3
<b>Warranty</b>	<b>4</b>
<b>Safety</b>	<b>5</b>
<b>Operation</b>	<b>11</b>
<b>Best Practices</b>	<b>12</b>
<b>Adjustments</b>	
<b>Hook Adjustment</b>	<b>13</b>
<b>Arm Position</b>	<b>14</b>
<b>Knife Replacement</b>	<b>15</b>
<b>Hook Replacement</b>	<b>18</b>
<b>Spear Installation</b>	<b>20</b>
<b>Maintenance</b>	<b>21</b>
<b>Setup</b>	<b>22</b>
<b>Startup</b>	<b>32</b>
<b>Specifications</b>	<b>33</b>
<b>Parts Book</b>	<b>35</b>
Upper Frame	36
Lower Frame	37
Left Clamp Tube	38
Right Clamp Tube	39
Hook Arm	40
Hook Cartridge	41
Knife Arm	42
Knife Cartridge	43
Manifold	45
Hydraulic Junction	46
Cylinders	47
Decals	48
Electrical	31
<b>Hydraulic &amp; Electrical Schematics</b>	<b>51</b>
<b>Troubleshooting</b>	<b>56</b>

## Contact Information

Hillco Technologies, Inc.  
1010 1st Avenue  
Nezperce, Idaho 83543

Phone 800-937-2461  
[www.hillcotechnologies.com](http://www.hillcotechnologies.com)  
email: [support@hillcotechnologies.com](mailto:support@hillcotechnologies.com)

# General Information

## **SERIAL NUMBER LOCATION**

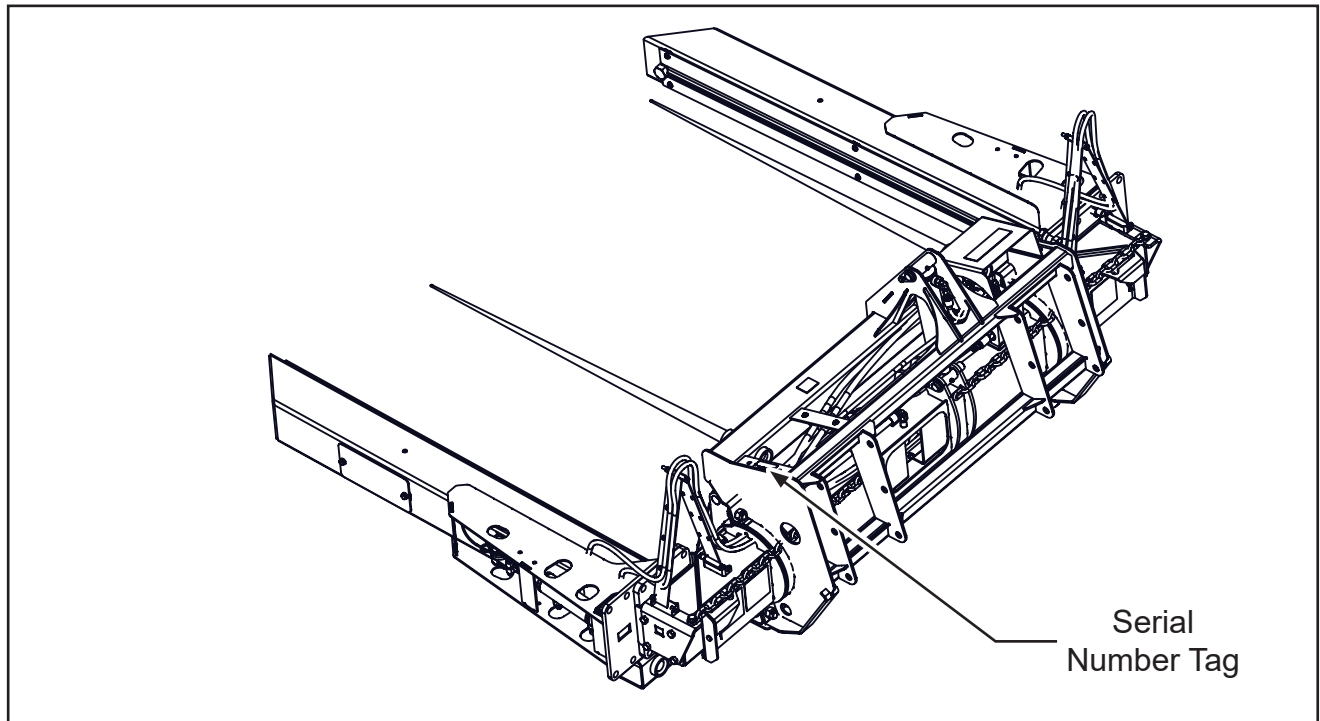

## **TEXT AND ILLUSTRATIONS**

The arrangement of this parts catalog is for easy identification of parts. All parts are illustrated in exploded views in proper relation to each other. Some diagrams refer to other pages for further information. Reference numbers used in the illustrations refer to line numbers in the part lists. The part lists appear to the right or below all diagrams and correspond with those diagrams. Included in the part lists, along with the reference numbers are part numbers, part descriptions and the quantity of the part required per Wrap Twine Remover System.

## **ABBREVIATIONS**

**SN** “Serial Number” refers to the serial number given to each WTR410/WTR510 by Hillco Technologies. See above for the Wrap Twine Remover System’s serial number location. This abbreviation is used interchangeably in both instances. Each Model WTR410/WTR510 uses the following serial number format:  
xxxx (sequential numbers).

**ASM** “Assembly” refers to a whole grouping of parts (shown in the diagram corresponding with the page where “ASM” is shown unless otherwise noted). Some assemblies have parts that are sold separately, however some must be purchased as a single unit. Hillco Product Specialists will be able to assist you with any questions.

**NS** “Not Shown” refers to a part that is not depicted in the illustration.

## **RIGHT AND LEFT IDENTIFICATION**

The reference to right-hand and left-hand in this catalog is identified by the operator sitting in the operator’s seat, looking toward the front of the machine (in normal forward travel).

## **PART ORDERS**

Orders must specify product model, serial number, correct part number, complete description, quantity required, method of shipment, shipping address, and billing address.



# Statement of Limited Warranty

## Class II Warranty

### Parts & Labor

Hillco warrants its Class II products to be free from defects in material and workmanship for a period of twelve (12) consecutive months following the warranty start date.

The warranty start date for Hillco Class II products is the date of the invoice, or the first date of use, whichever is earliest. Once the warranty period has begun, it cannot be stopped.

Hillco warrants genuine Hillco replacement parts and components to be free from defects in material and workmanship for a period of ninety (90) consecutive days following the Hillco invoice date, or the remainder of the original equipment warranty period, whichever is longer.

Hillco's obligation under this product and parts warranty shall be limited to repairing or replacing, free of charge to the original purchaser, any part(s) that, in Hillco's judgment, shows evidence of such defect.

### Limitations to Warranty

This warranty does not cover:

- 1) Any product damaged by accident, abuse, misuse, negligence, or improper maintenance.
- 2) Any unauthorized product alteration or modification.
- 3) Any unauthorized repairs made with parts other than genuine Hillco parts unless specifically authorized by Hillco.
- 4) Any repairs performed by anyone other than Hillco or an authorized Hillco dealer unless specifically authorized by Hillco.
- 5) Any claims directly resulting from improper installation, except those installations performed by Hillco.

### Warranty Procedure

No warranty claims will be accepted without a completed Dealer PDI on file at Hillco.

For warranty submission instructions please email [warranty@hillcotechnologies.com](mailto:warranty@hillcotechnologies.com) and request a Warranty Claim Form. Complete the Warranty claim form and submit the claim, via email to [warranty@hillcotechnologies.com](mailto:warranty@hillcotechnologies.com) within thirty (30) days of the occurrence of the failure and within the warranty period.

All warranty work must be performed, and claims submitted, within thirty (30) days of the occurrence of the claim and within the warranty period.

All parts removed during warranty repair should be held for a period of one hundred twenty (120) days after the warranty claim has been submitted to Hillco.

Hillco reserves the right to either inspect the product at the original retail purchaser's location, or the authorized Hillco's dealer's location; or require it to be returned to Hillco, transportation charges prepaid, for inspection.

For additional details on Hillco's Warranty Program refer to Hillco's current "Warranty Policy Guide".

### Limitation of Liability

Hillco makes no express warranties other than those, which are specifically described herein. Any description of the goods sold hereunder, including any reference to buyer's specifications and any descriptions in circulars and other media published by Hillco is for the sole purpose of identifying such goods and shall not create an express warranty that the goods shall conform to such description.

THIS WARRANTY IS EXPRESSLY IN LIEU OF ALL OTHER WARRANTIES EXPRESSED OR IMPLIED. There are no implied warranties of merchantability or fitness for a particular purpose. This warranty states Hillco's entire and exclusive liability and buyer's exclusive remedy for any claim for damages in connection with the sale or furnishing of Hillco products, their design, suitability for use, installation, operation, or for any claimed defects herein. HILLCO WILL IN NO EVENT BE LIABLE FOR ANY INCIDENTAL OR CONSEQUENTIAL DAMAGES WHATSOEVER, NOR FOR ANY SUM IN EXCESS OF THE PRICE RECEIVED FOR THE GOODS FOR WHICH LIABILITY IS CLAIMED.

Neither representative of Hillco nor any dealer associated with Hillco has the authority to change the items of this warranty in any manner whatsoever, and no assistance to purchaser by Hillco in the repair or operation of any Hillco product shall constitute a waiver of the conditions of this warranty, nor shall such assistance extend or revive it.

Hillco reserves the right to make improvements in design or changes in specifications at any time, without incurring any obligation to owners of units previously sold.

D-220525ADB03

## SAFETY ALERT SYMBOL



This Safety Alert symbol means  
ATTENTION! BECOME ALERT! YOUR SAFETY IS INVOLVED!

The Safety Alert symbol identifies important safety messages on the Hillco Wrap Twine Remover and in the manual. When you see this symbol, be alert to the possibility of personal injury or death. Follow the instructions in the safety message.

## SIGNAL WORDS

Note the use of the signal words DANGER, WARNING, and CAUTION with the safety messages. The appropriate signal word for each message has been selected using the following guidelines:



**DANGER**

**DANGER** - An immediate and specific hazard, which WILL result in severe personal injury or death if the proper precautions are not taken.



**WARNING**

**WARNING** - A specific hazard or unsafe practice, which COULD result in severe personal injury or death if proper precautions are not taken.



**CAUTION**

**CAUTION** - Unsafe practices which COULD result in personal injury if proper practices are not taken, or as a reminder of good safety practices.

**NOTICE**

**NOTICE** - is used to address practices not related to physical injury.

## OPERATION SAFETY

1. Read and understand the Operator's Manual and all safety labels before operating the Wrap Twine Removal system.
2. Make sure that all controls are in the neutral position before starting the tractor.
3. Clear the area of all bystanders, especially children, before starting the system and during operation.
4. Make sure all safety shields are in place before operating the Wrap Twine Remover. Never operate the machine with the shields removed.
5. Keep hands, feet, hair and clothing away from all moving and/or rotating parts.
6. Stay seated in the cab during operation.
7. Operate controls only when sitting in the seat of the tractor.
8. Always travel at a safe speed. Use caution when making turns or traversing ditches.

## HYDRAULIC SAFETY

1. Do not search for high-pressure hydraulic leaks without hand and face protection. A tiny, almost invisible leak can penetrate the skin, thereby requiring immediate medical attention.
2. Use cardboard or wood to detect leaks – never your hands!
3. Before inspecting the hydraulic system of the Wrap Twine Remover system, install the safety stops where applicable.
4. Before operating the WTR, ensure that there are no obstructions between or around the arms.
5. Maintain proper hydraulic fluid levels.
6. Ensure all fittings and hoses are in good repair.



## SERVICING AND MAINTENANCE SAFETY

1. Review the Operator's Manual and all safety items before servicing or maintaining the Wrap Twine Remover.
2. Stop the engine, wait for any moving parts to stop, block the tires, and the cylinder areas before servicing, repairing, adjusting, or maintaining the Wrap Twine Remover system.
3. Place Selector switch to middle position and set hydraulics to float (if possible) to relieve system pressure.
4. Hydraulic oil is under pressure. Use caution when dealing with the hydraulic system.
5. Keep hands, feet clothing and hair away from all moving and/or rotating parts.
6. Clear the area of bystanders, especially children, when carrying out any maintenance, repairs or making any adjustments.

## HIGHWAY OPERATION AND TRANSPORT SAFETY

1. Check with local authorities regarding transport on public roads. Obey all applicable regulations and laws.
2. Check clearance elevations and widths of implement for travel near power lines, bridges, trees, etc.
3. Always travel at a safe speed. Use caution when making corners or meeting traffic.
4. WTR is not designed to transport bales long distances on public roads.

## READ OPERATOR'S MANUAL SYMBOL

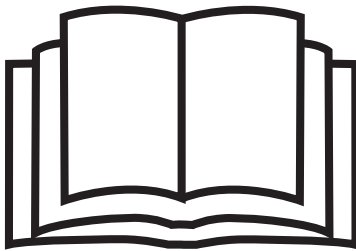

Decals, which display the —Read Operator's Manual symbol, are intended to direct the operator to the Operator's Manual for further information regarding maintenance, adjustments and/or procedures for particular areas of the Wrap Twine Remover. When a decal displays this symbol, refer to the Operator's Manual for further instructions.

## **Safety Labels**

Familiarize yourself with the location of all safety labels. Read them carefully to understand the safe operation of your machine.

### **TO APPLY NEW OR REPLACEMENT LABELS**

1. Make sure the label area is smooth by removing any debris such as dirt or old labels.
2. Wash the area with soap and water and then dry it thoroughly.
3. After the area has completely dried, peel the backing off the safety label and place it onto the cleaned area.
4. Make sure all areas of the label have adhered to the machine by pressing down on the entire face of the label, including the corners.

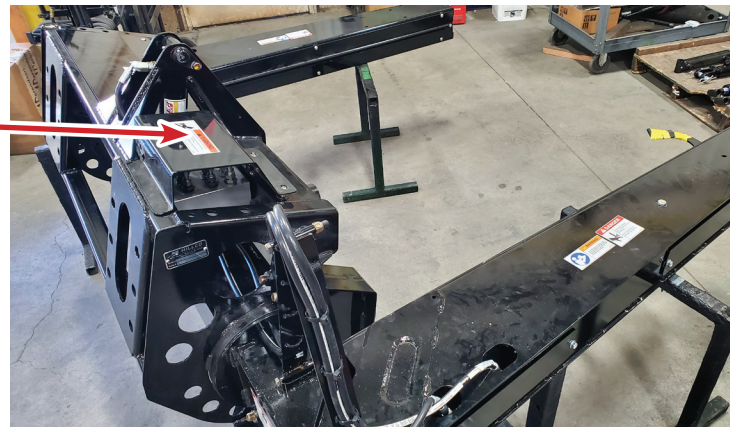
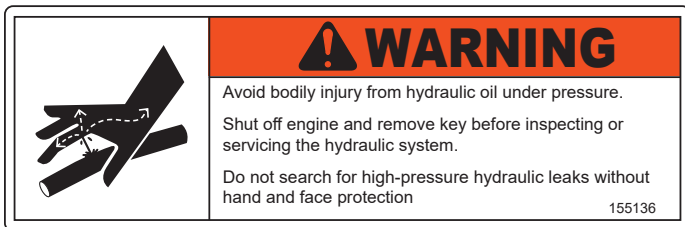
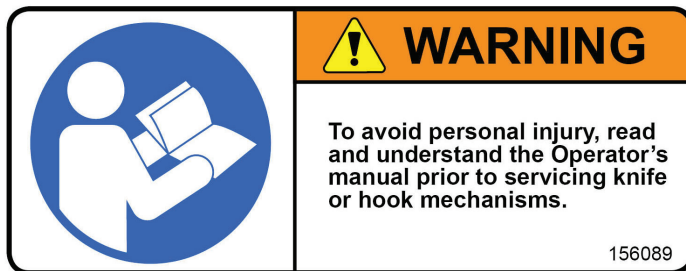

**! DANGER**



**PINCH POINT HAZARD**

- Keep hands, feet and body away from moving parts.
- Do not stand or climb on machine when operating.

155139

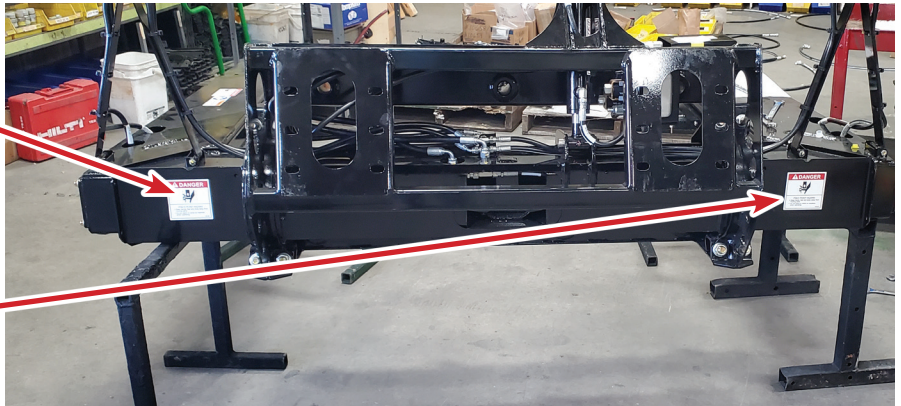

**NOTICE**

**Maximum Lifting Capacity:**

**3000 lbs  
(1360 kg)**

156088

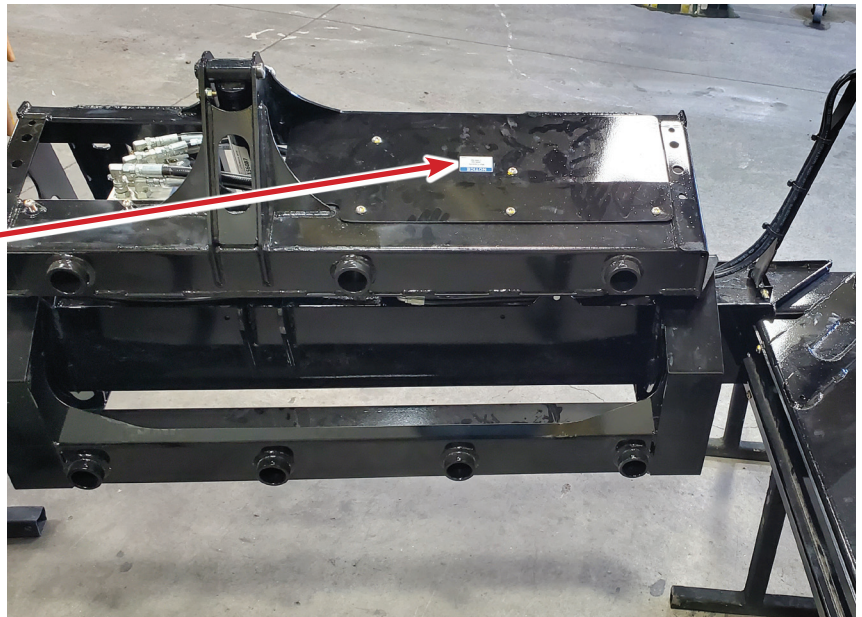

**! WARNING** *Do not cycle the knife or hooks when someone is near the WTR.*

**Hydraulics, Electrical, and Implement connections.**

Attach the Wrap Twine Remover to your loader as per the instructions in your loader's Operator's Manual. Connect the two hydraulic hoses to the service ports on the loader tractor. (If your tractor is not equipped with service ports at the front of the loader you can route hoses from the rear of the tractor, these hoses are not included in the kit.) Connect the electrical plug near the manifold and the system will be ready for use.

## Operation:

The WTR has three functions controlled by a switch box in the cab.

**Bale Squeeze** – Used to squeeze the bale and position the hooks and knife into position to grab and cut the bale twine/wrap.

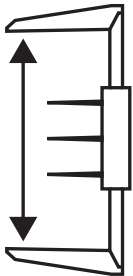

**Rotate** – Used to rotate the squeeze arms out of the way when handling bales that are tightly stacked.

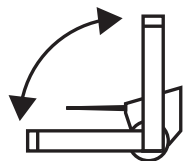

**Cut** – Cycles a series of hooks on the left arm and a knife on the right arm. The hooks grab into the bale and capture the twine/wrap while the knife simultaneously cuts the twine/wrap.

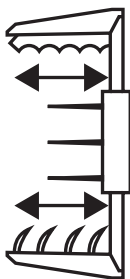

### NOTICE

*If WTR power is connected to permanent power, leave the switch in the center (rotate) position to avoid draining the battery.*

## Best Practices

Spears the bale so that the arms are located at the widest point on the bale.

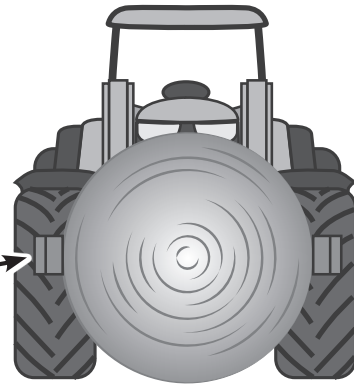

Make sure the bale is against the WTR frame.

Position the bale squeeze arms so that they are level with the bale.

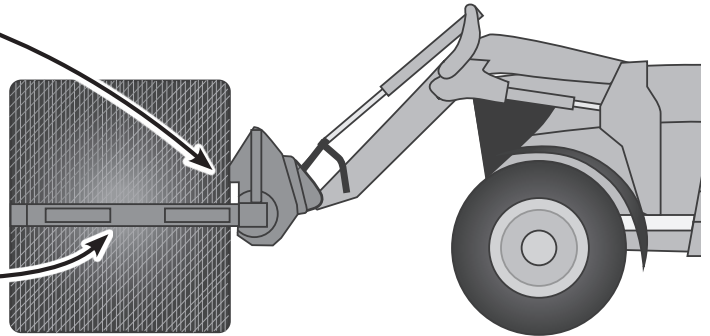

Engage the knife and hooks and leave engaged holding the wrap/twine. Select Bale Squeeze on switch and open the arms to put some tension onto the wrap/twine. Select Rotate and rotate the arms upward to pull the wrap free from the bale. Then tip the bale downward and allow it to slide forward off the spears. Discard wrap/twine in garbage.

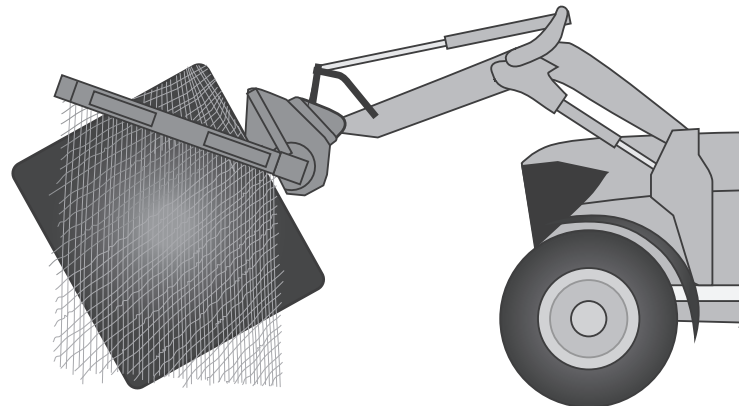

# Adjustments

## Hook Adjustment

The hook bank can be moved in/out of the hook arm to adjust how deep the hooks are reaching into the bale. For twine wrapped bales it is best to have the hooks reach further into the bale to ensure they get each string. For round bales with net wrap the hooks can be adjusted outwards to reduce the amount of hay that is trapped by the hooks.

Located hook adjustment bolts A & B. Use a 9/16 socket to adjust.

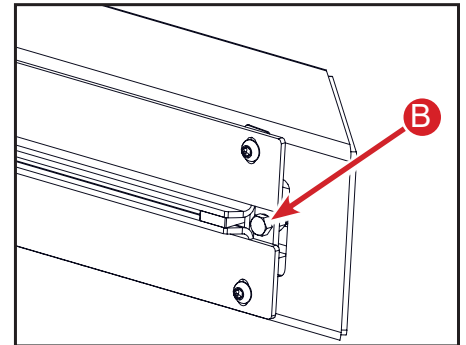
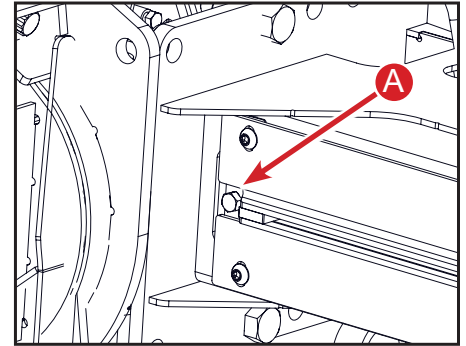
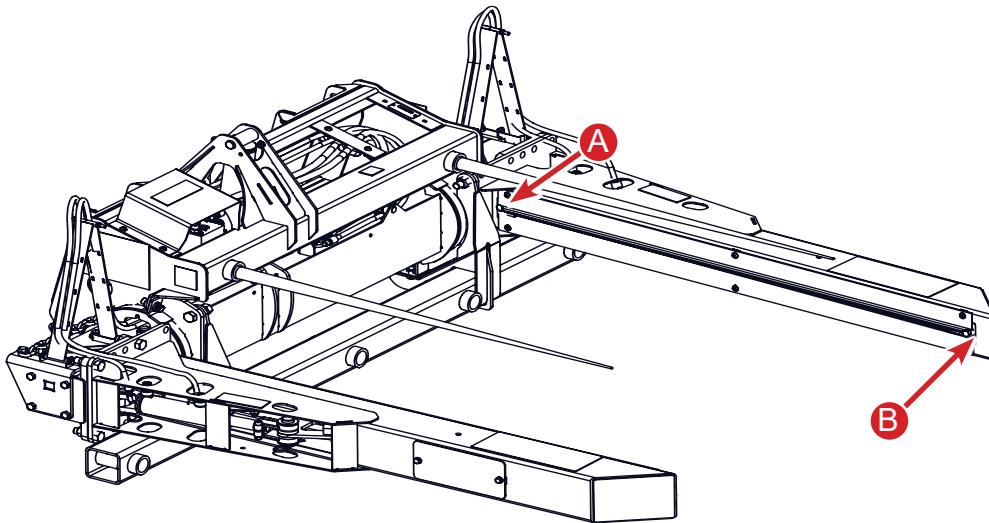

Important Notes when adjusting the hooks:

Turning the below bolts clockwise will adjust the hooks further into the bale.

Turning the below bolts counter clockwise will adjust the hooks further away from the bale.

When adjusting adjust in small increments and also adjust each side evenly. It is recommended to adjust bolt A two revolutions and then adjust bolt B two revolutions so the hook cartridge does not bind up.

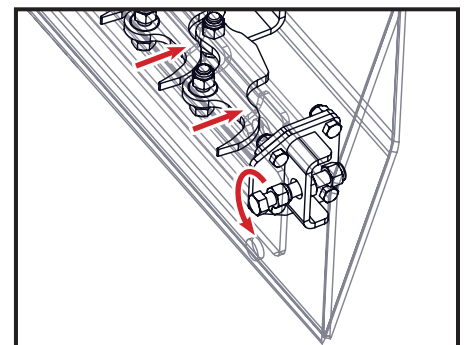
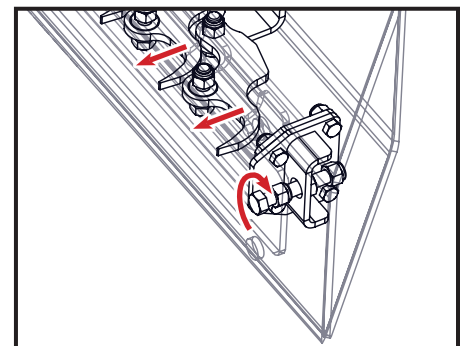

### **Important**

***Do not use an electric or air impact gun to adjust hooks. This will cause the hooks to bind. Use hand ratchet only.***

## Arm Position

There are two settings for arm mounting location.

If only handling round bales we recommend placing the arms in the narrow position.

The maximum bales size in the narrow position is 101.5"

If handling large square bales that are 8' in length we recommend the wide position.

The maximum bales size in the wide position is 111.5".

To adjust the arms to the alternate position remove the (4) M12 bolts (A) and nuts on each side and move the arm to the other position.

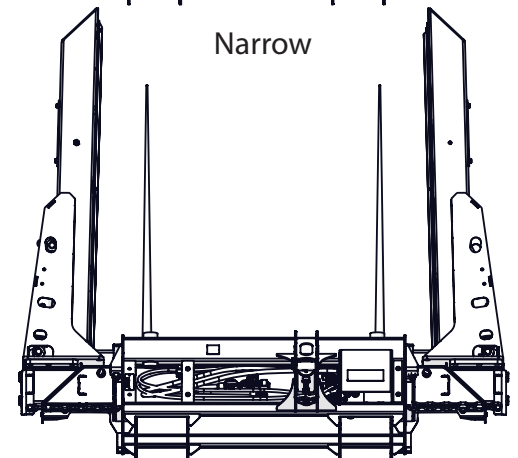
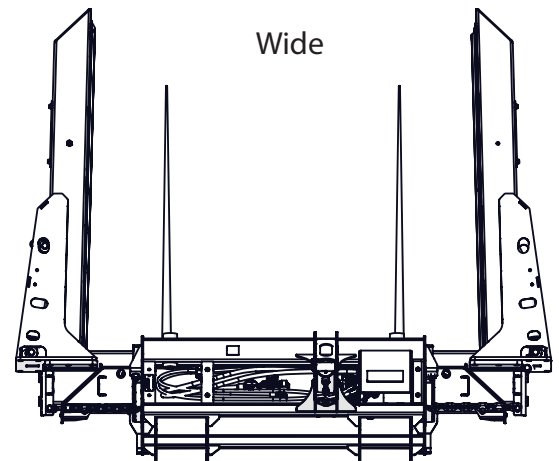
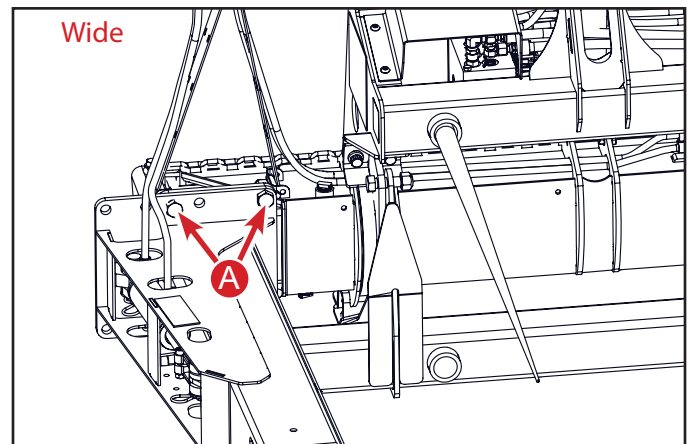
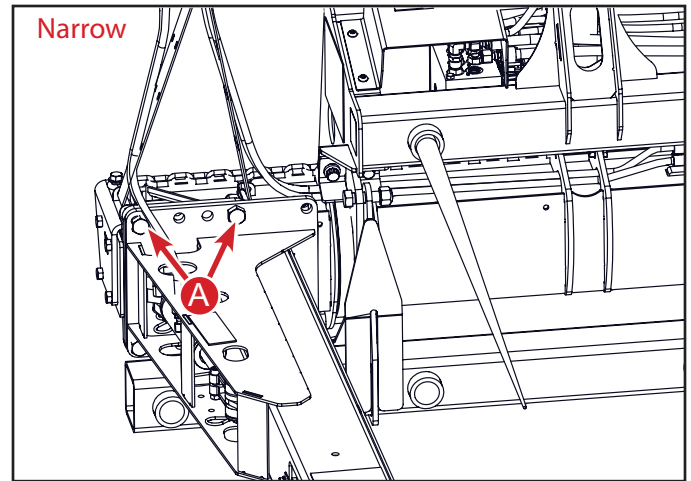

# Knife blade replacement

Use the following procedure to safely remove the knife cartridge for blade replacement

Open the arms at least 1 foot from their fully closed position then shut off the vehicle engine and remove the key.

**! WARNING** The knife blade is very sharp! Wear proper protective equipment while handling the knife.

Cycle the knife and stop the knife when it is sticking out of the arm. Use duct tape and apply tape to the sharp edge of the knife to prevent injury. Do not touch the knife blade as it is sharp.

After taping cycle blade so the rod holes for the cylinder line up with the cutouts on the arm so the pin can be removed.

Disconnect the rod end of the cylinder (A) from the knife cartridge.

Careful to not move the knife cartridge as the blade can then protrude past the arm.

If equipped with the net wrap hook, open the front access cover (C) and disconnect the struts from the rocker assembly. The struts will be removed with the knife cartridge.

**NOTICE** If the blade is cycled while the safety pin is in place, irreparable damage will occur.

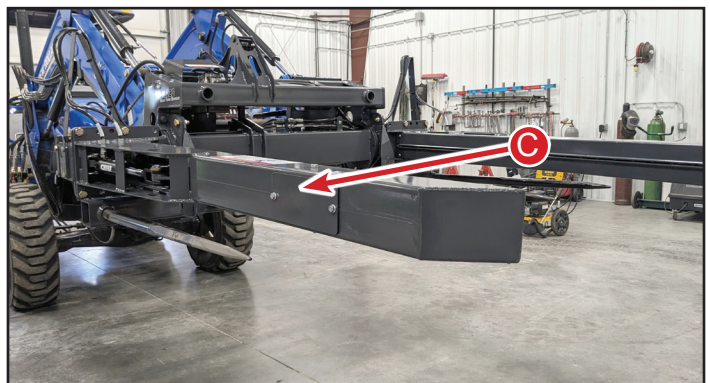
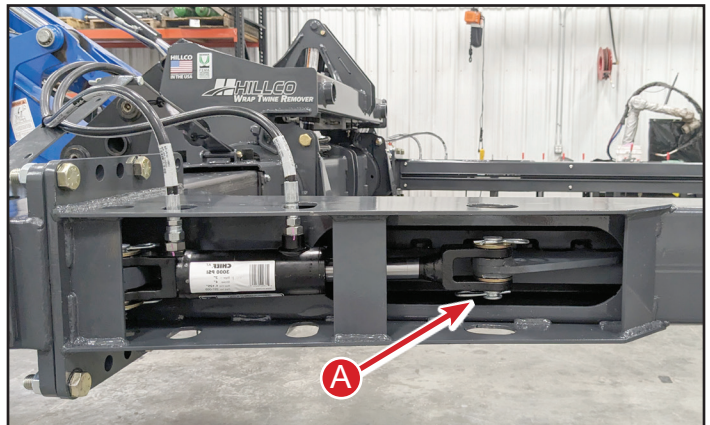
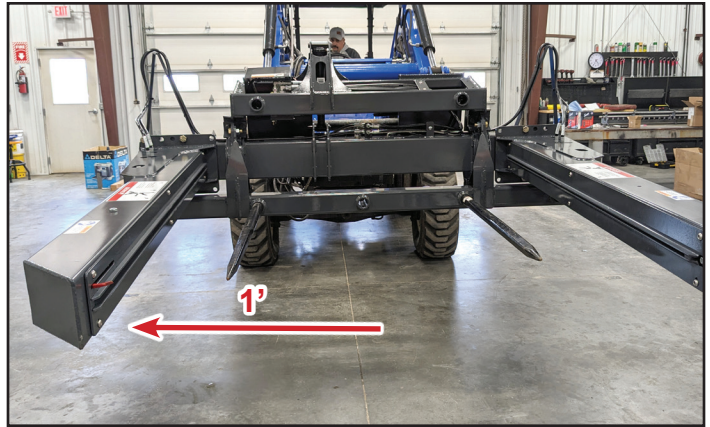

Remove the six bolts (A) from the inside face of the cartridge then remove the cartridge (B) taking extra care to ensure that the knife blade remains inside the cartridge. You will have to tip the cartridge downward to clear the arm frame.

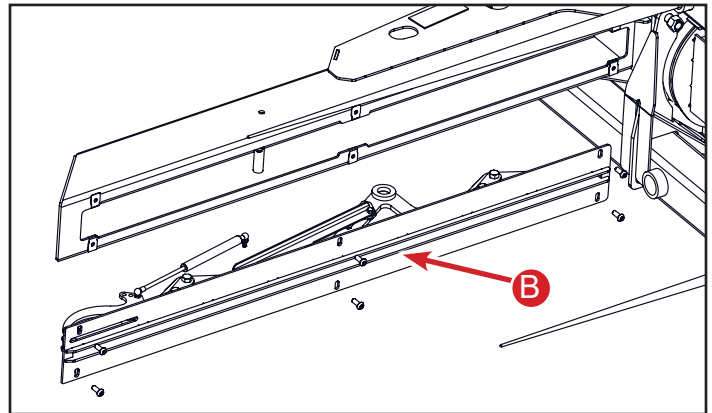
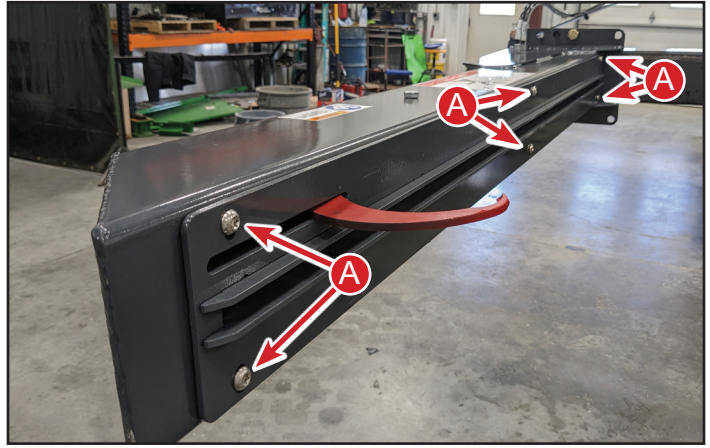

Set the cartridge on a sturdy work surface and remove the linkages (C) that connect the knife holder to the cartridge.

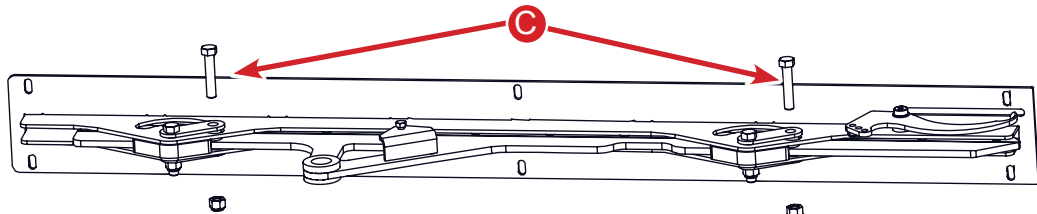

Slide the knife holder forward then rotate to remove the knife holder from the cartridge frame as shown.



Using a T30 wrench remove the screws (A) holding the blade to the knife holder. When re-installing the blade make sure to match the angle of the blade to the angle of the knife holder at the front and rear. Use locktite on all bolts and tighten them to 75 in-lbs.

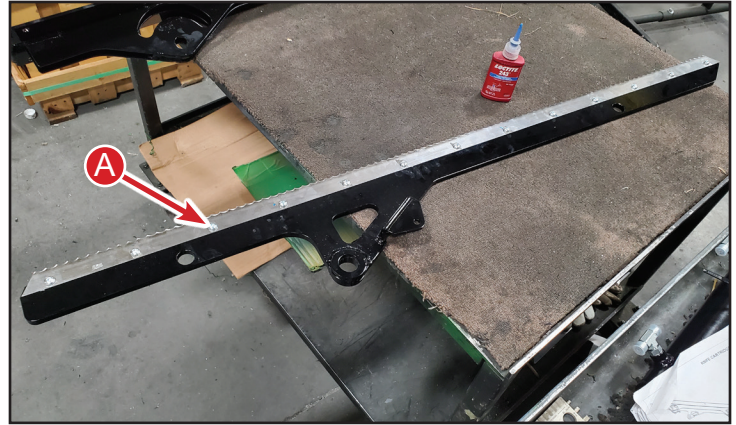

Assembly is the reverse of the process above.

## Hook replacement

Use the following procedure to safely remove the hook cartridge for hook replacement.



### CAUTION

Be aware of pinching hazards while handling the hook cartridge.

Open the arms at least 1 foot from their fully closed position. Ensure that the hooks are fully retracted. Shut off the vehicle engine and remove the key.

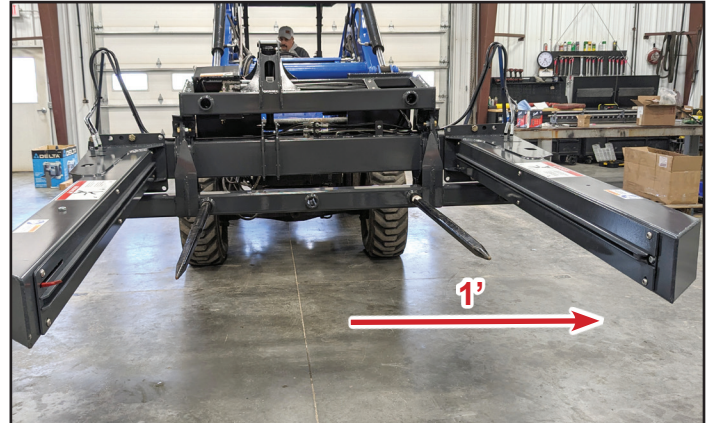

Disconnect the rod end of the cylinder from the hook cartridge.

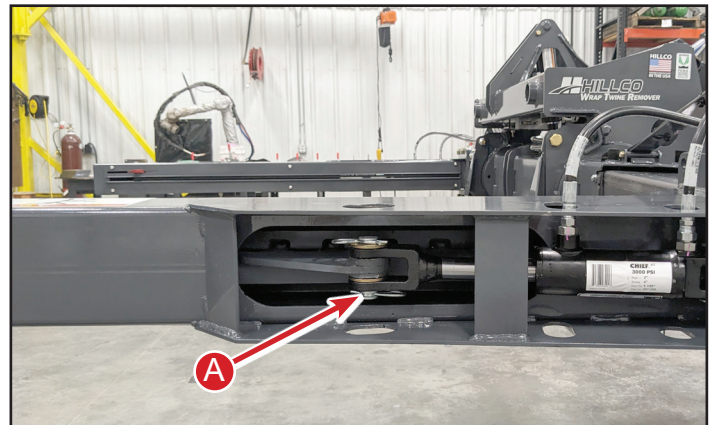

Remove the six bolts (B) from the inside face of the cartridge then remove the cartridge.

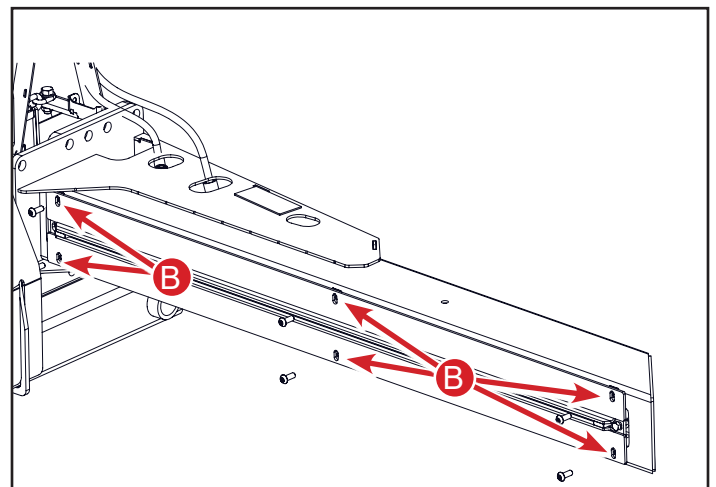

Set the cartridge on a sturdy work surface. The hooks can be removed one at a time by removing the two bolts (A) that attach them to the pivot frame and actuator arm. It is recommended that you replace the bushing when replacing the hook.

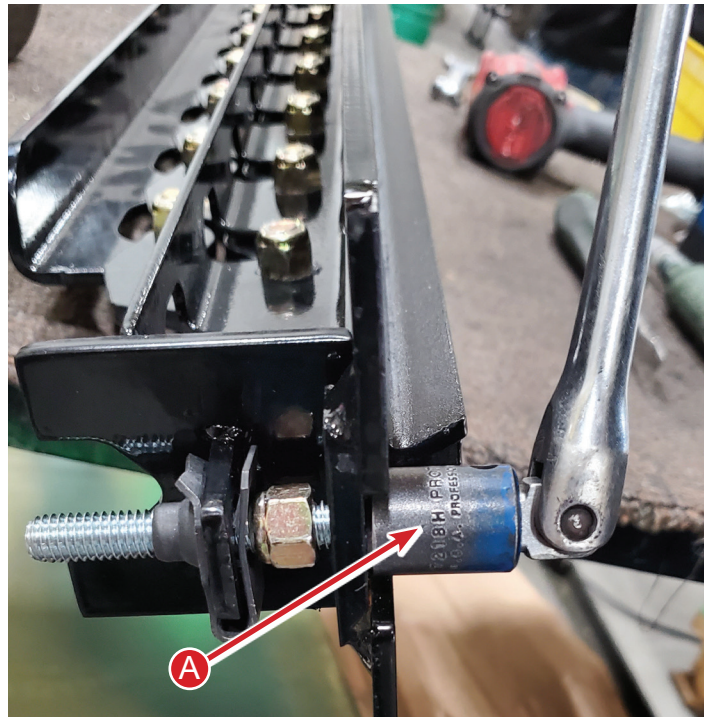

Remove the bolt (B) that connects to the linkage and the bolt (C) that the hook rotates around. Remove and replace bushing along with new hook.

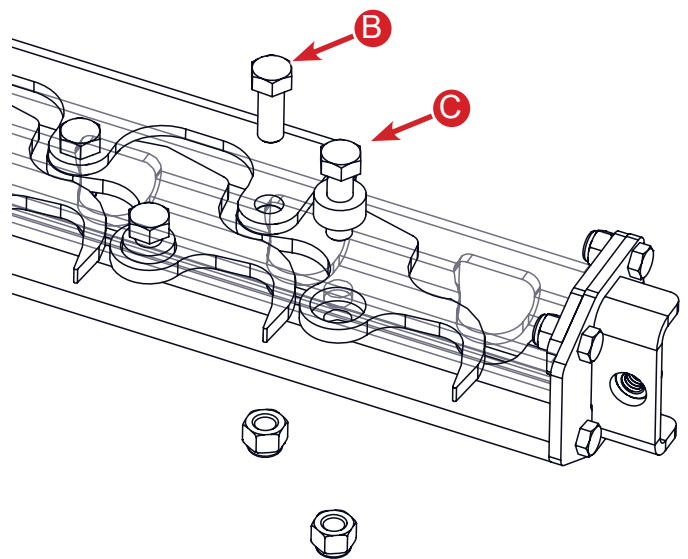

When re-installing the hooks, tighten the bolt (C) that passes through the pivot bushing snugly but only tighten the bolt (B) on the actuation arm tight enough that the bolt can still be turned freely by hand. If the bolts to the actuation arm are too tight the mechanism can bind.

Assembly is the reverse of the process above.

## Spear Installation

The WTR comes with two upper (A) and an optional five lower (B) spear locations. Up to seven spears in any combination can be installed. Three spears are included. An additional fourth spear is included with the optional lower mount.

To remove the spears use a wrench to hold the square part of the spear and a socket to remove the nut.

When reinstalling the spears it is recommended to put anti seize on tapered part of spear to prevent it from rusting into the housing.

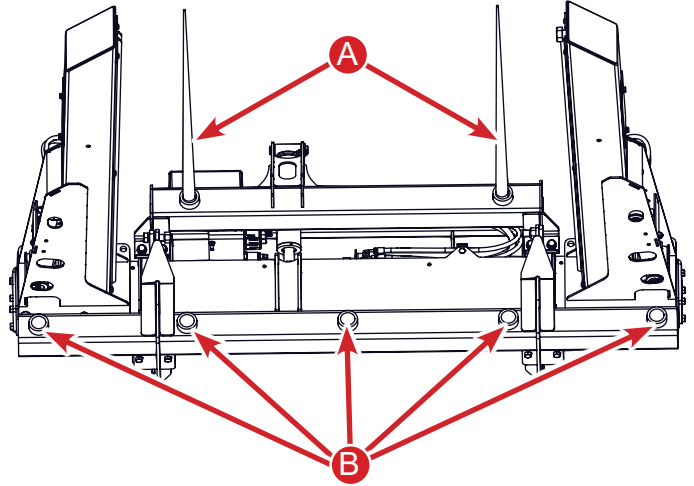

# Maintenance

## Every 200 HRS

Lubricate all 4 sides of both arms (A) with a dry graphite where they slide in and out. Do this prior to the initial use and every 200 bales or as needed.

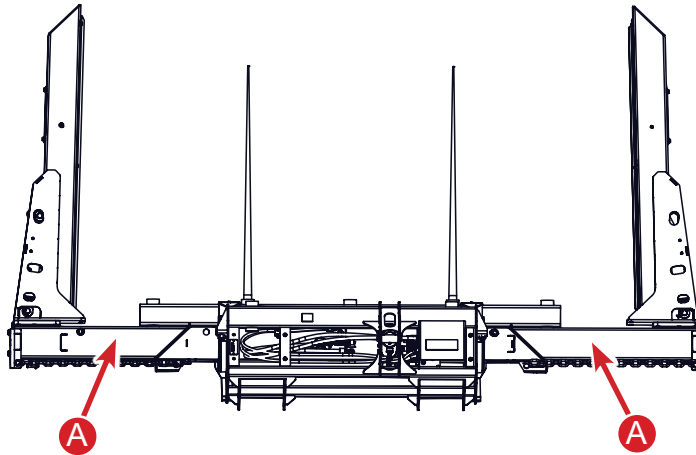

Adjust poly wear pads (B) to reduce slop over time as WTR is used. With arms fully extended tighten so there is no slack between poly pad and arm (two on each side).

Lubricate pivot bushings (C) on each side with dry graphite every 200 bales.

Grease pivot cylinder ends (D) every 200 bales.

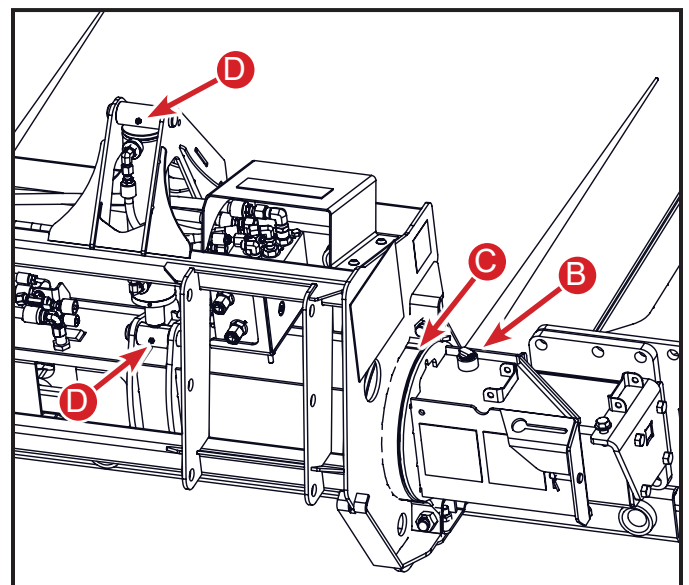

## Annual Maintenance

Inspect blade for damage/wear. Replace if damaged.

Inspect hooks for damage.

If bent straighten or replace hook.

If broken replace hook.

# Setup

## Read this prior to beginning the setup procedure:

Due to the variety of different loader options on the market, the WTR is shipped without service hoses from the manifold to the loader hydraulics. Secondly, if your tractor does not have auxiliary hydraulics at the loader then hoses from the rear remotes will need to be routed to the WTR. It is advisable to have these hoses made prior to beginning the system setup.

Hillco recommends a 3/8 inch service hose with 90° -8 (1/2") SAE Oring Face seal fittings on one end and the quick coupler option of your choice on the other end.

### Step 1:

#### Unpackaging and Inventory:

Unpack the WTR system, including the boxed items, and compare the items to the inventory list below. If there are any damaged or missing items contact Hillco Technologies, Inc. at 1-800-937-2461 for assistance.

Item Description	Quantity	Weight (Pounds)
Center Assembly	1	640
Hook Arm Assembly	1	200 (WTR510), 175 (WTR410)
Knife Arm Assembly	1	200 (WTR510), 175 (WTR410)
Bale Spears	2*	30
--Boxed Items --		9
Hose Support	4	
Operators Manual	1	
3/4-10 x 2-1/2" Bolt, Grade 8	8	
3/4-10 Stover Nut, Grade 8	8	
Switch Box Assembly	1	
Harness, Switch box to Valve	1	
Ram-Mount U-bolt kit	1	
Ram-Mount Double Swivel Arm	1	
5/16-18 x 3-1/2" Bolt, Grade 5	6	
5/16 Ny-lock Nut, Grade 8	6	

\* Additional spears are available at the time of order.

Step 2:

Rotating the center assembly:

Using one of the spears as a lever, rotate the center assembly upwards to provide access to the rear of the frame.



The spear can rest against the ground to help stabilize the center assembly.



Step 3:

Installing service hoses:

Locate and remove the two caps from the fittings on the rear of the manifold. (It may be easier to remove the manifold cover using a T45 torx bit).

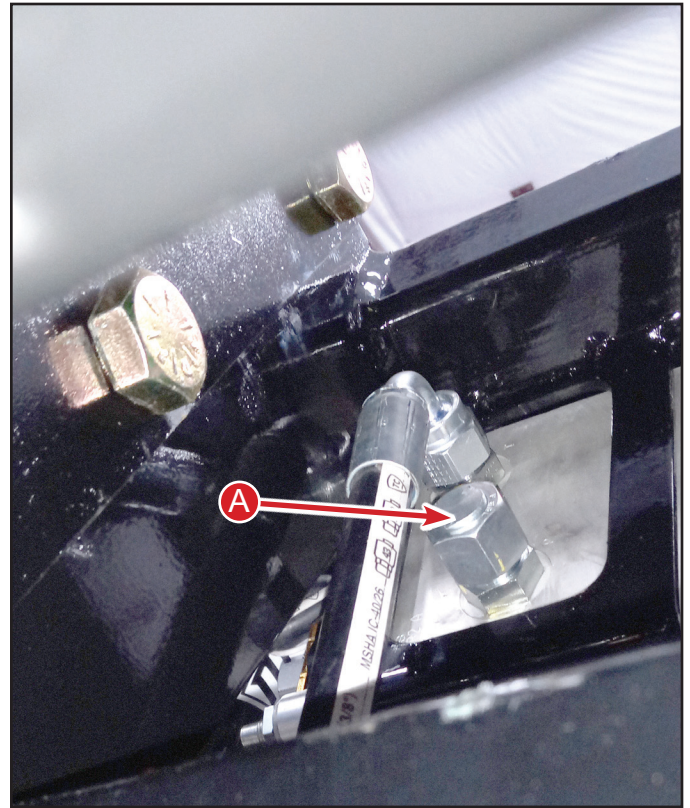

Connect the hoses to the fittings at the rear of the manifold, then route the service hoses towards the right side of the center frame. The hoses should exit under the right side of the manifold cover. (B)

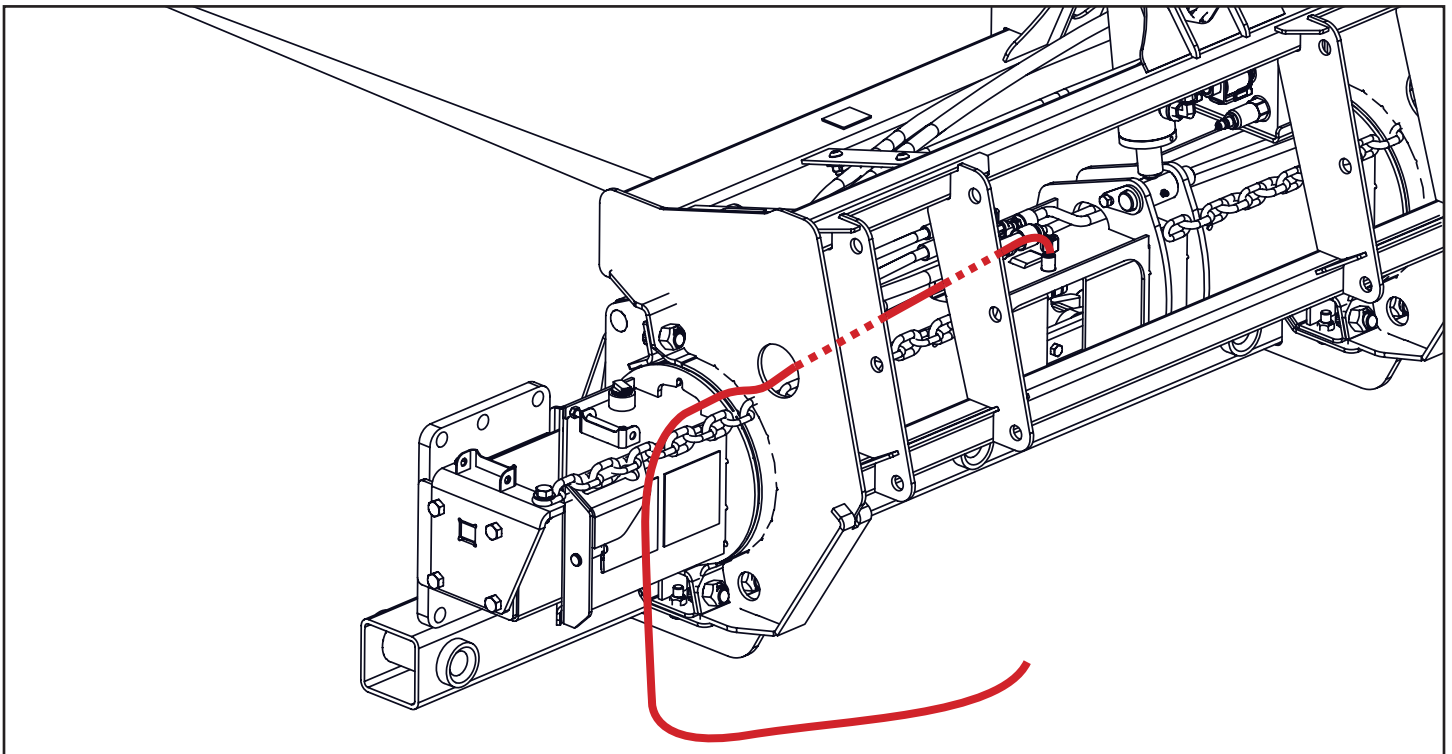

#### Step 4:

##### Installing loader adapter

Locate the loader adapter kit. It should include a left and right adapter plate of your choice along with 12ea.  $\frac{3}{4}$ -10 x 1-3/4 bolts and nylock nuts. (A) Position the left plate between the mounting ears at the rear of the frame and install the 6 bolts from the inside and start the lock nuts. Tighten all nuts using an impact wrench and repeat this process for the right plate.

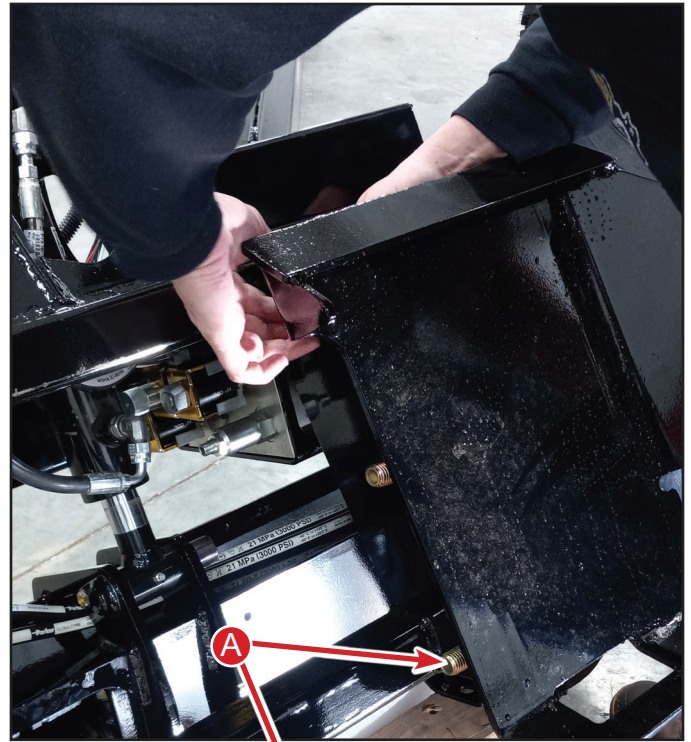

Note: The skidsteer mount is shown, your kit may vary.

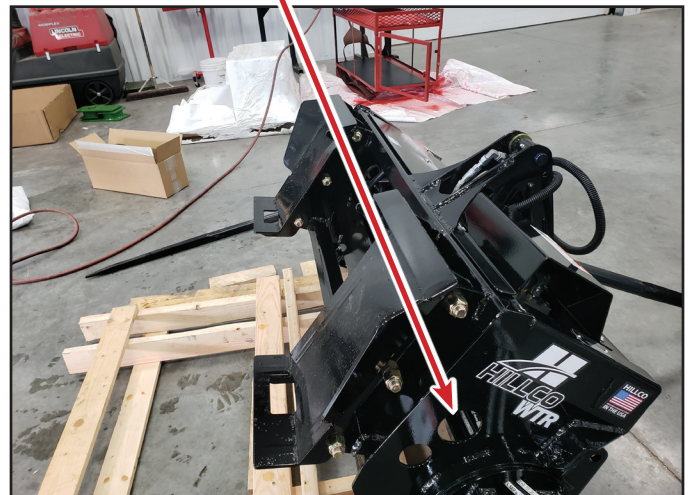

#### Step 5:

Pick up the center frame and secure it to your loader tractor.



The knife arm is installed on the right side of the machine and the hooks arm is on the left as you sit in the machine.

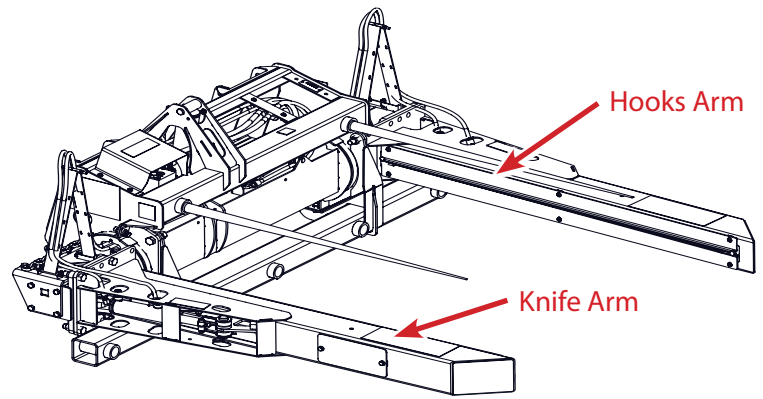

Step 6:

Installing Knife Arm.

Cut the zip tie (B) holding the arm hoses in place and set the hoses out of the way for now.



Lower the center frame with your loader tractor and position the arm near the right side mount plate so that it can be bolted in place.

There are two positions to install the arms. The narrow position (shown) is optimal for round bales, while the wide position is intended for large square bales that are 8 feet long or longer.

See Arm Adjustment Section for more details on arm width.

Locate the (4) 3/4 x 2.5" bolts (B) and 3/4" stover nuts.

Install arm to center frame using the 3/4" bolts and nuts.

Torque to 380 ft-lbs

D-250113DMC01A

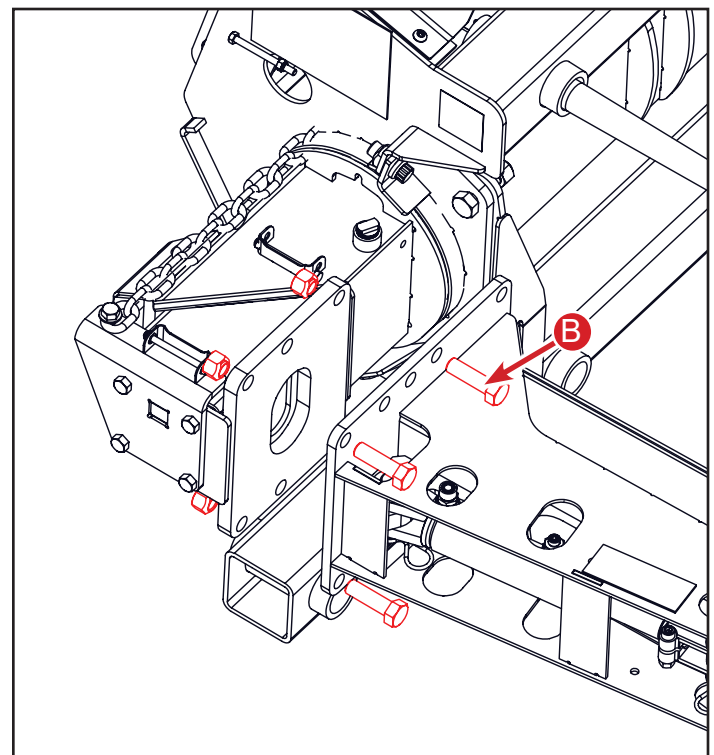

## Step 7: Hook Arm Installation

Install the hook arm position so it matches the position the knife arm.

Locate the (4) 3/4 x 2.5" bolts (A) and 3/4" stover nuts.

Install arm to center frame using the 3/4" bolts and nuts.

Torque to 380 ft-lbs

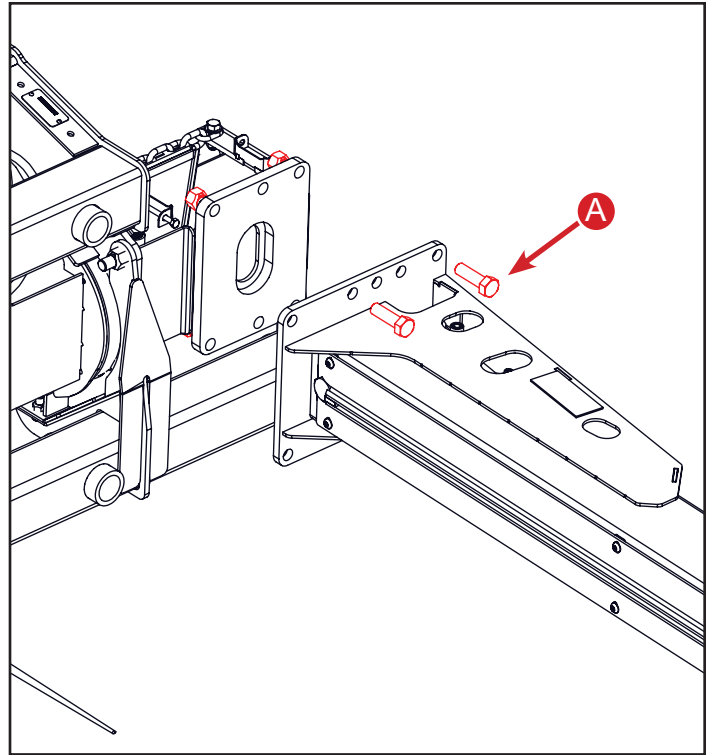

Step 8:

Installing hose guides:

Locate the 4 hose guides (A) from the box as well as (6) 5/16 x 3.5" bolts (B) and 5/16 nylock nuts.

Install the hose guides as shown and tighten. Note that the bolts must be left loose enough to allow the guides to move freely as the arm extends and retracts.

Repeat this process on the opposite side.

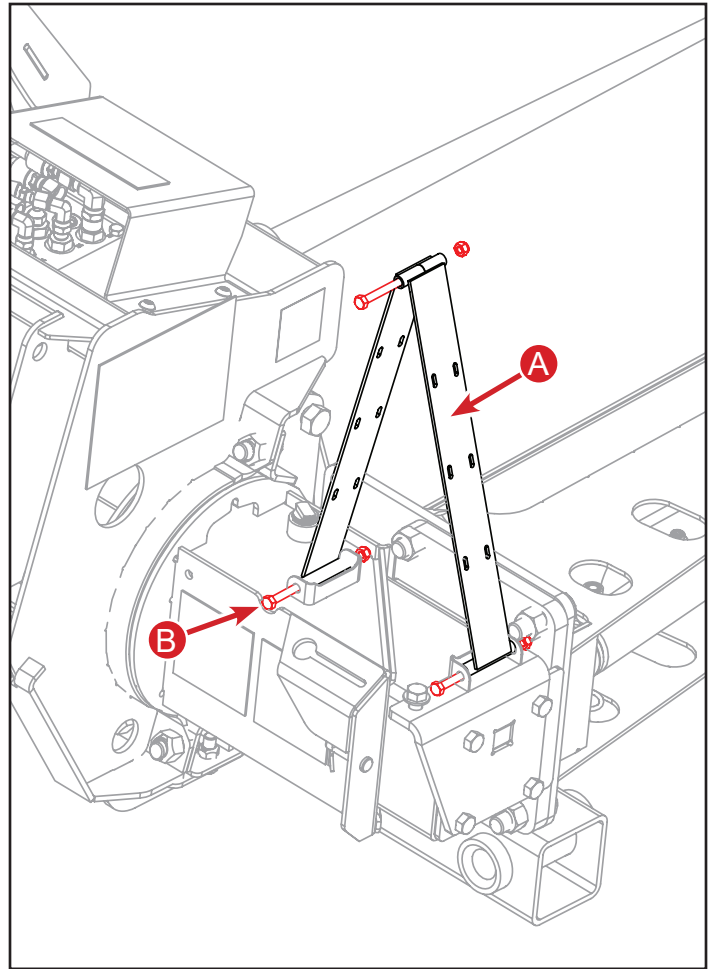

## Step 9:

### Connecting arm cylinder hoses.

Route the hoses from the center frame, over the top of the guides, and through the two holes in the top of the arm. Connect them to their corresponding ports on the arm cylinder. The ends of the hoses are different to prevent connecting them incorrectly. Note: You may need to loosen the opposite ends of these hoses to get any twists out.

Zip tie the hoses to the guides then tighten all connections near the arm cylinder.



## Installing electrical.

Find a convenient location inside the cab to mount the switch box and secure it using the provided Ram mounts. You will need to provide 12 volts – 5 amps to the orange wire and ground to the black wire. Hillco recommends connecting the switch box to a keyed power source to avoid accidentally draining your tractor's battery if the switches are left on.

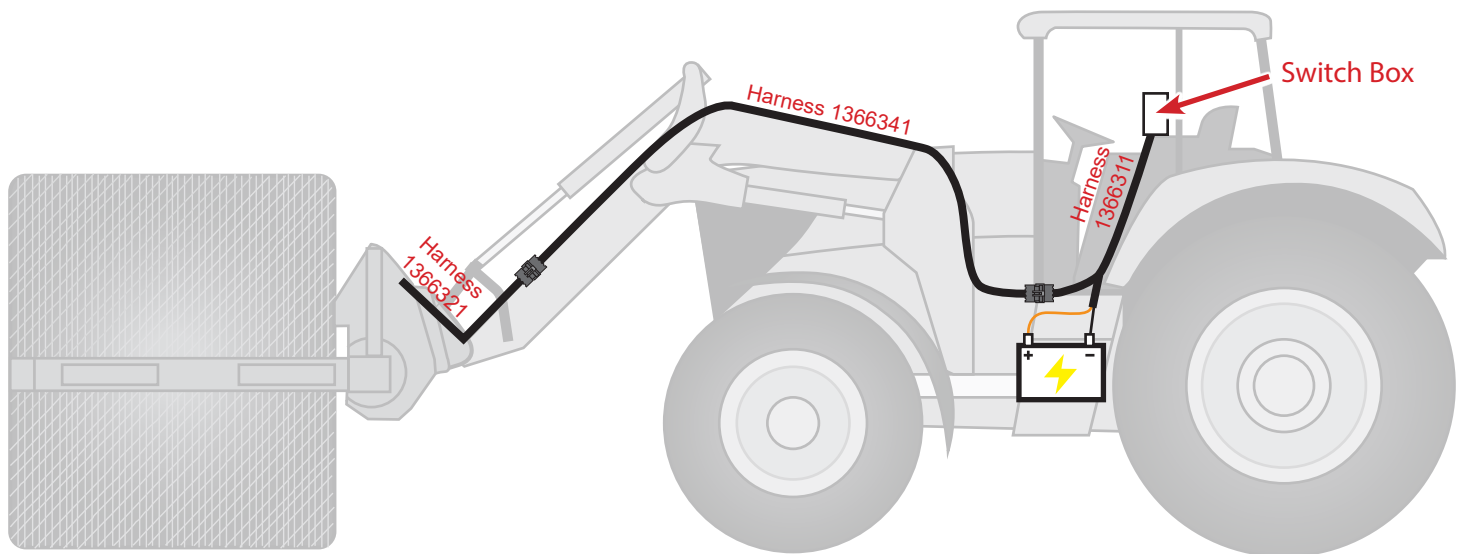

Route harnesses on the inside of the loader frames to protect the harnesses.

Connect the extension harness to the manifold harness (already installed) then route the free end down the side of your loader to the switch box in the cab and connect the two together. Be sure to secure the harness with zip ties so it won't rub or pinch as the loader is used.



## Startup

Please read through the following procedure fully prior to attempting the first startup of your WTR.

**NOTE:** if your tractor is rated for more than 12 GPM of Hydraulic Flow we recommend reducing the hydraulic flow. Refer to your tractor's operator's manual to reduce flow.

Rotate: 

Make sure there are no people standing near the unit. Start the tractor, verify the switch box is in the center position, then slowly provide oil to the WTR. If nothing happens, try reversing the hydraulics. The arms should slowly rotate upwards as you apply oil. Once the arms have rotated fully upwards, slowly reverse the hydraulic flow to lower them. Repeat 3 or 4 times to remove all air from the cylinder. It is important to do this step slowly until all air is removed from the system to prevent the arms from rotating too fast and damaging the cylinder.

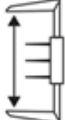
Squeeze: 

Change the switch to the bale squeeze position (A red light should illuminate on the switch). Provide oil to the WTR. If nothing happens slowly reverse the flow. The arms will start to extend, most likely one at a time. It is normal for the arms to chatter as the air is bled from the system. Once the arms are fully extended, Hillco recommends that a dry lubricant, such as graphite, be sprayed liberally onto the arm tubes. Cycle the arms fully 3 or 4 times to purge all air from the system.

Cut: 

Change the switch to the cut position. (A red light should illuminate on the switch). Double check no one is standing near the WTR, then slowly provide oil. As before, if nothing happens try reversing the flow. If you position the loader properly, you can see the hooks and knife deploy.

Note that the knife blade is shipped with tape over it for safety. Now is a good time to carefully remove the tape from the knife edge. The best way to do this is to slowly cycle the cut mechanism and stop as the blade is exposed. This will provide access to remove the tape. Cycle the knife and hook 2 – 3 times to purge air from the system.

Shut down the tractor engine and inspect the WTR for any oil leaks. Hillco also recommends checking the hydraulic fluid level on tractor.

Thank you for purchasing your Hillco Technologies, Inc. product. Please contact our customer support department with any questions regarding your WTR system. 800-937-2461

# Specifications

WTR410 FOR 4' DEEP ROUND BALES AND 4' LARGE SQUARE BALES

WTR510 FOR 5' DEEP ROUND BALES

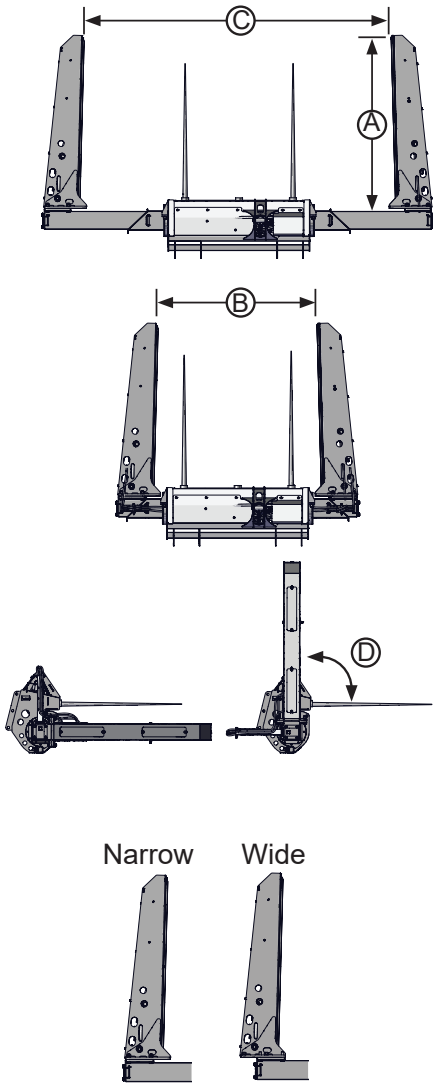

Two mounting options for arms to widen or narrow squeeze

	WTR410 Narrow	WTR410 Wide	WTR510 Narrow	WTR510 Wide
A	58"		70"	
B - Retracted	53.5"	63.5"	53.5"	63.5"
C - Extended	101.5"	111.5"	101.5"	111.5"
D - Rotation	90° Arm Rotation Upwards			
Weight	1,000 lbs		1,200 lbs	
Handling Capacity	3,000 lbs			
Spears	Heat Treated and Forged			
Spear Adapters	1-1/4" Taper Threaded Style			
E - Lower Spear Mount	Optional (up to 5 additional spears)			
Tractor Adapters	Euro	John Deere 600	Skid Steer	

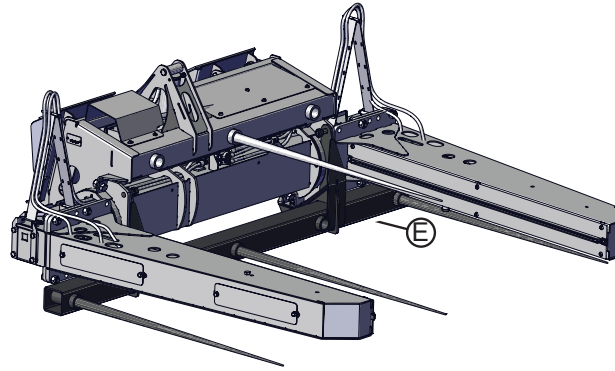

Due to different variations in tractors and skid steers in hydraulic options hoses and couplers are not included.

Supply hoses from tractor to WTR are not included. Manifold fittings are -8 (1/2") flat face oring.

Hydraulic Couplers not included.

WTR410 FOR 4' DEEP ROUND BALES AND 4' LARGE SQUARE BALES

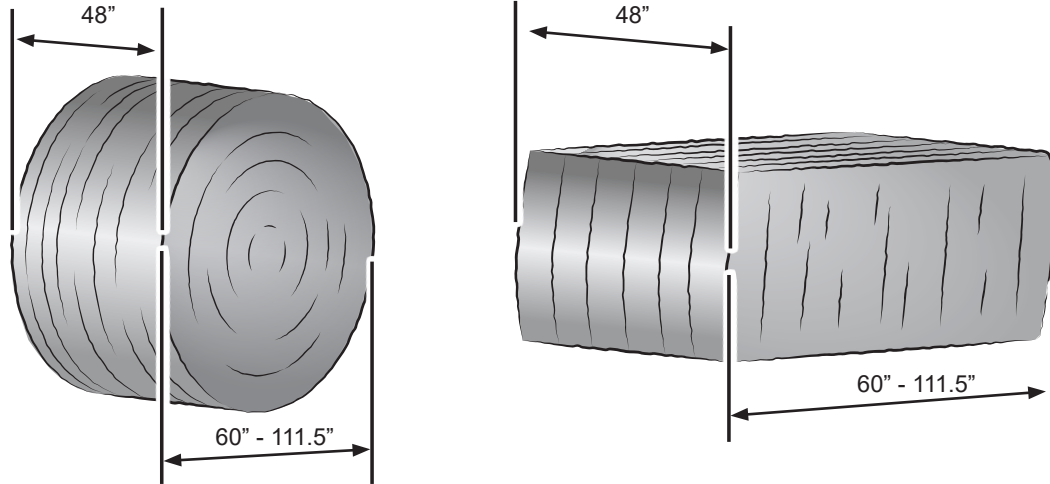

WTR510 FOR 5' DEEP ROUND BALES

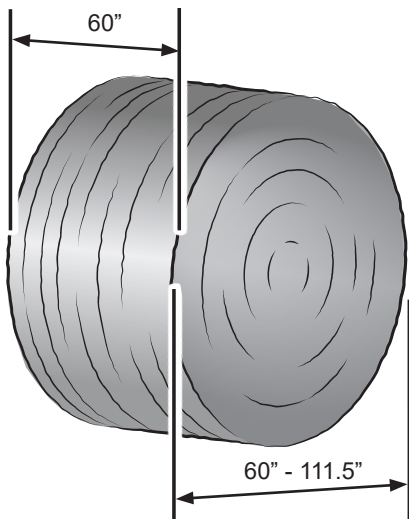

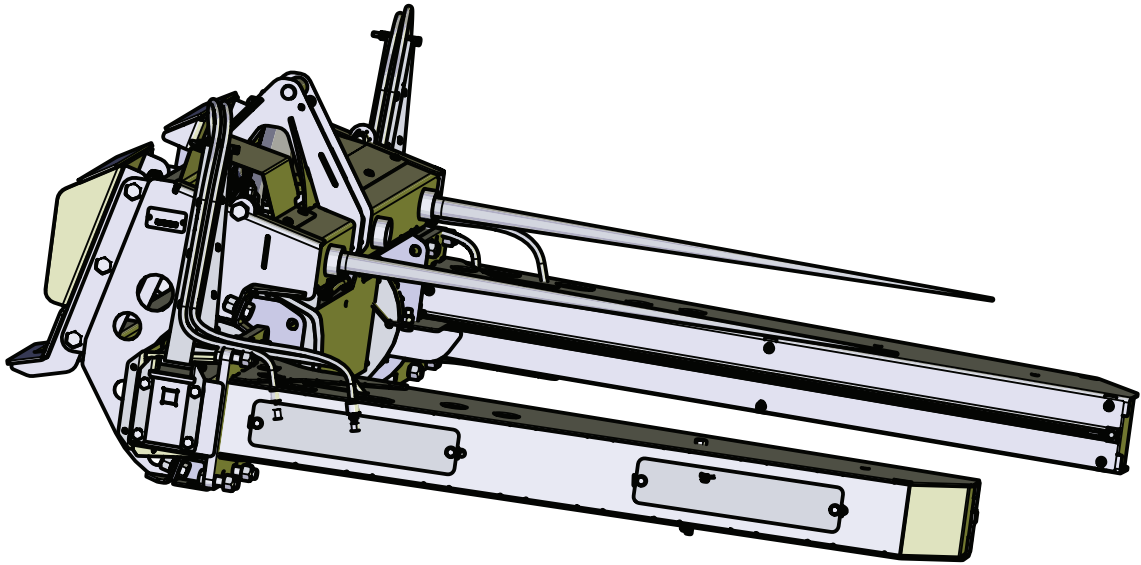

# Model WTR410 WTR510 Wrap Twine Remover Parts Manual

D-211027DMC01

## Upper Frame

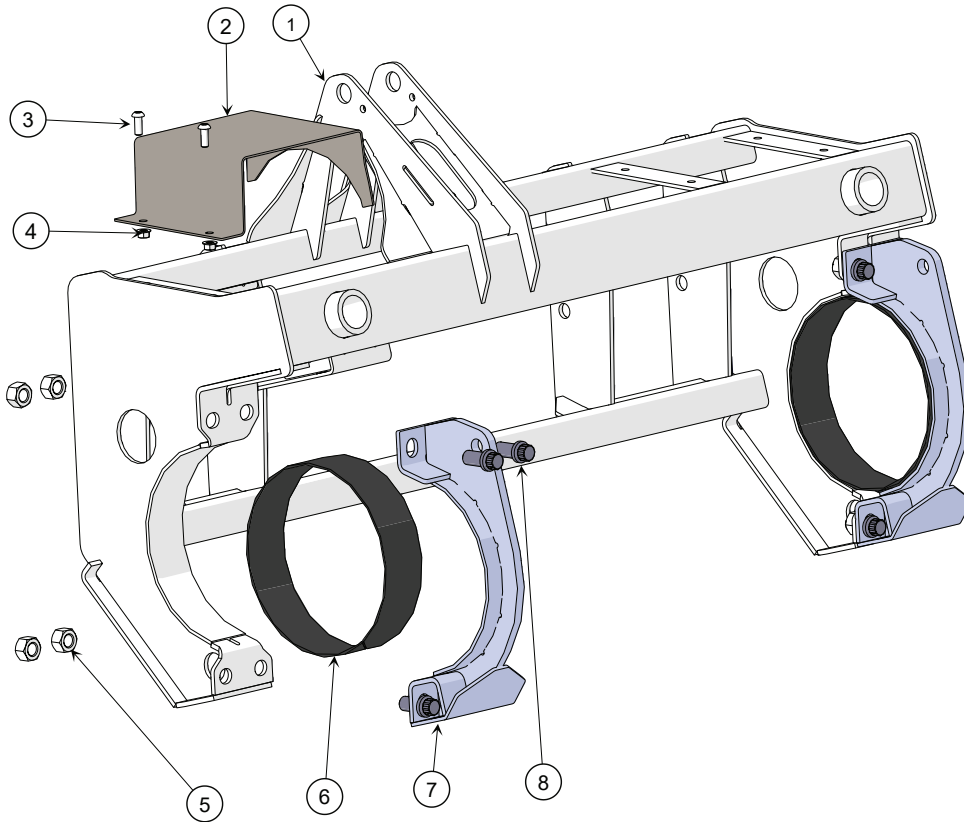

BOM ID	Part No.	Qty	Description
1	1381732	1	FRAME
2	1383331	1	SHIELD, MANIFOLD
3	257.006.016	2	SCREW, PHM, TX, 3/8-16 X 1"
4	216.006	2	216.006
5	188.012	8	NUT, HX,STV,GR8 3/4-10
6	1366162	2	ROTATE BUSHING
7	1361634	2	PIVOT CLAMP
8	269.012.024	8	SCREW,CAP,FERRY 3/4-10 X 1-1/2

## Lower Frame

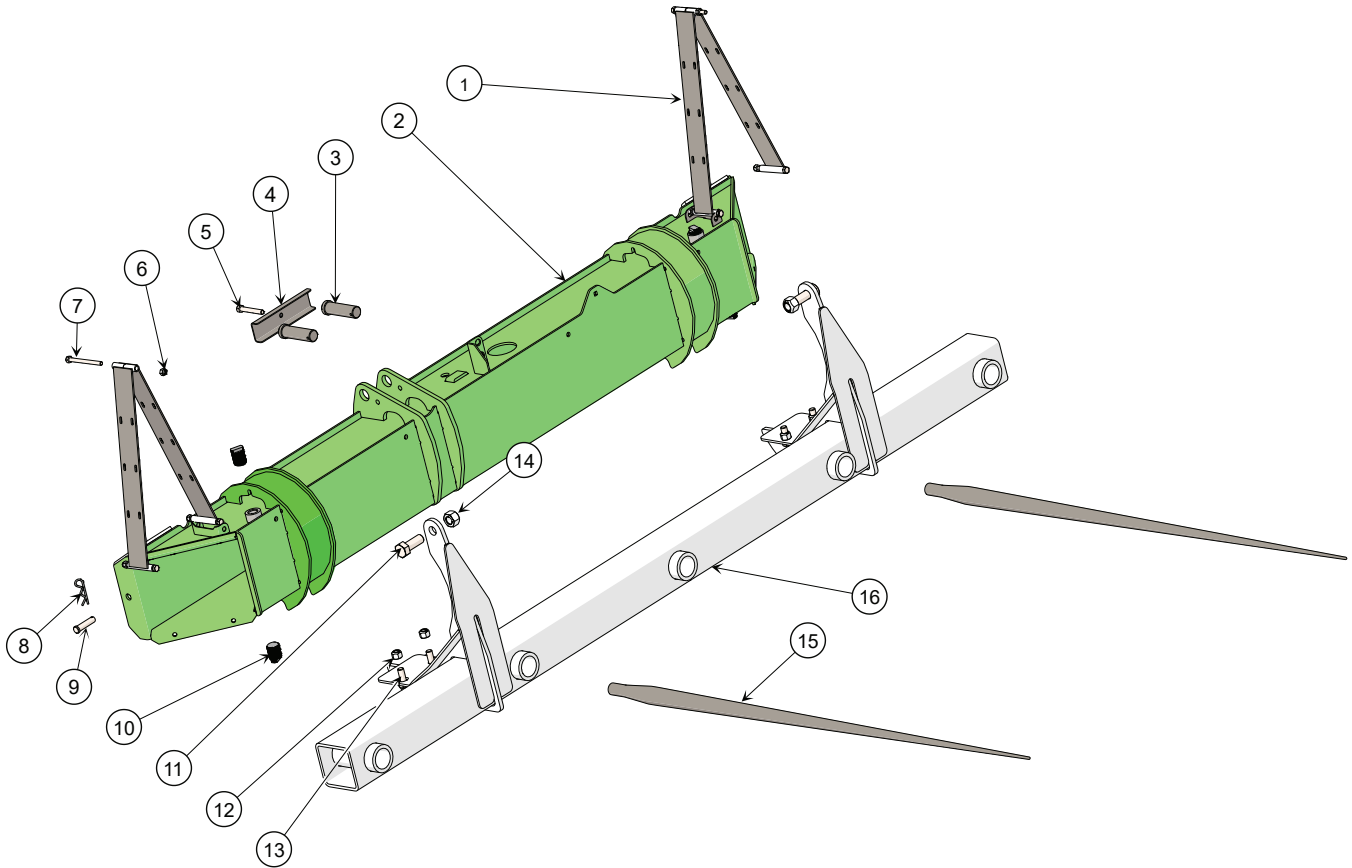

BOM ID	Part No.	Qty	Description
1	1356012	4	HOSE SUPPORT
2	1355874	1	CLAMP FRAME
3	156261	2	PIN, CYLINDER, 1"OD X 2-15/16" LONG
4	1361961	1	PIN LOCK, CLAMP CYLINDER
5	102.006.040	1	BOLT,HX,GR8 3/8-16X2-1/2
6	187.005	6	NUT,HX,NYL,GR8 5/16
7	101.005.056	6	BOLT,HX,GR5 5/16-18X3-1/2
8	144.#11	2	PIN,HITCH,CLIP
9	141.008.032	2	1/2"X2"L
10	1383191	4	PAD, WEAR, ROUND
11	102.012.032	2	BOLT,HX,GR8 3/4-10X2
12	188.008	4	NUT,HX,STV,GR8 1/2
13	102.008.020	4	BOLT,HX,GR8 1/2-13X1-1/4
14	188.012	2	NUT,HX,STV,GR8 3/4
15	156048	2	BALE SPEAR, 49 INCH
16	1377391	1	LOWER SPEAR FRAME

## Left Clamp Tube

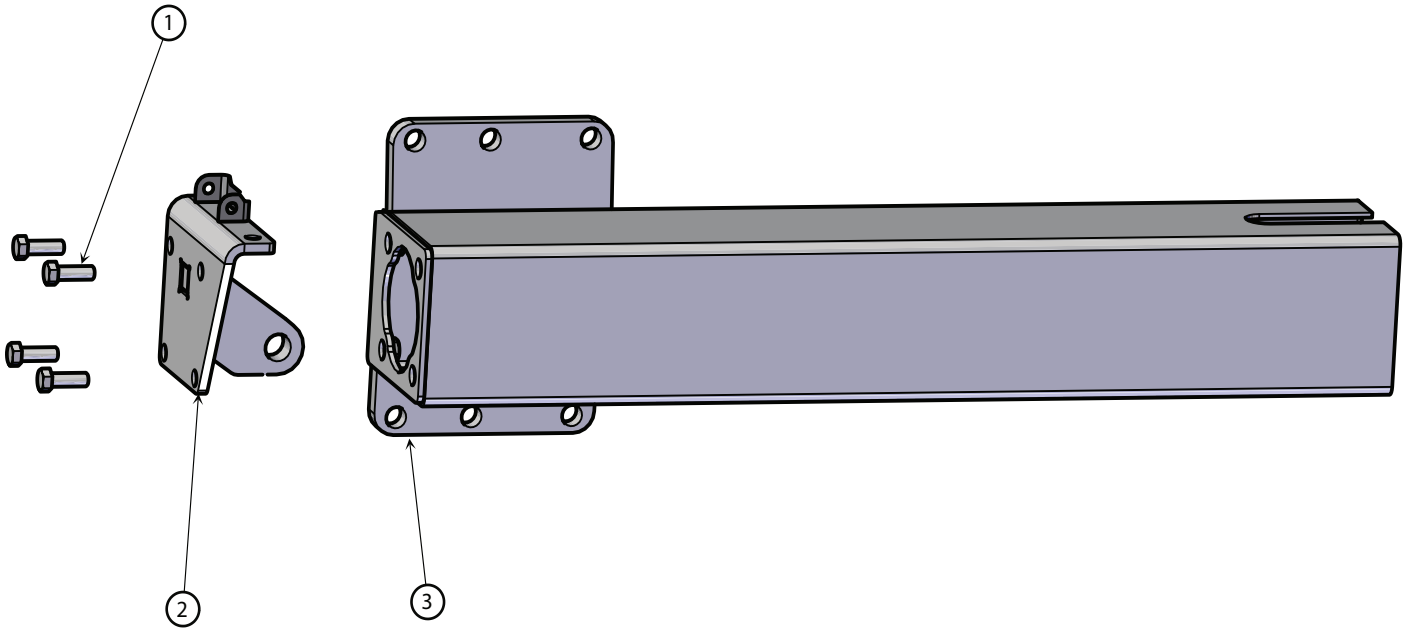

BOM ID	Part No.	Qty	Description
1	102.008.024	5	BOLT, HX, GR8 1/2-13X1-1/2
2	1385871	1	MOUNT, CYLINDER, LEFT
3	1376743	1	CLAMP TUBE, LEFT

# Right Clamp Tube

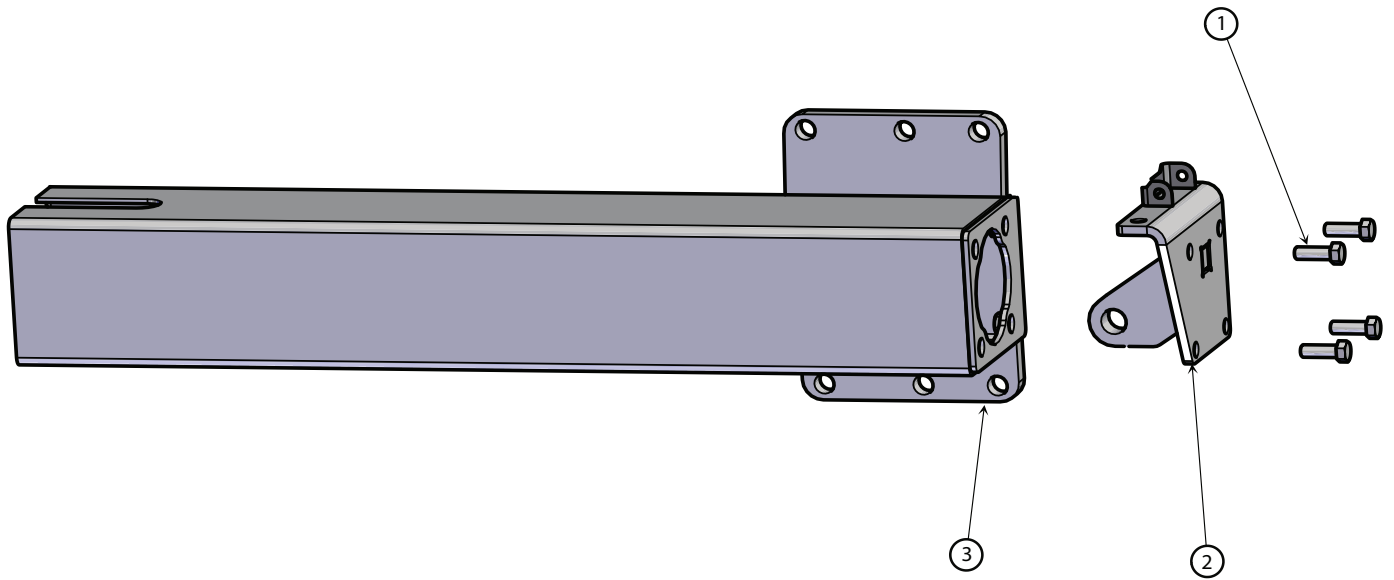

BOM ID	Part No.	Qty	Description
1	102.008.024	4	BOLT,HX,GR8 1/2-13X1-1/2
2	1385891	1	MOUNT,CYLINDER, RIGHT
3	1385821	1	CLAMP TUBE, RIGHT

## Hook Arm

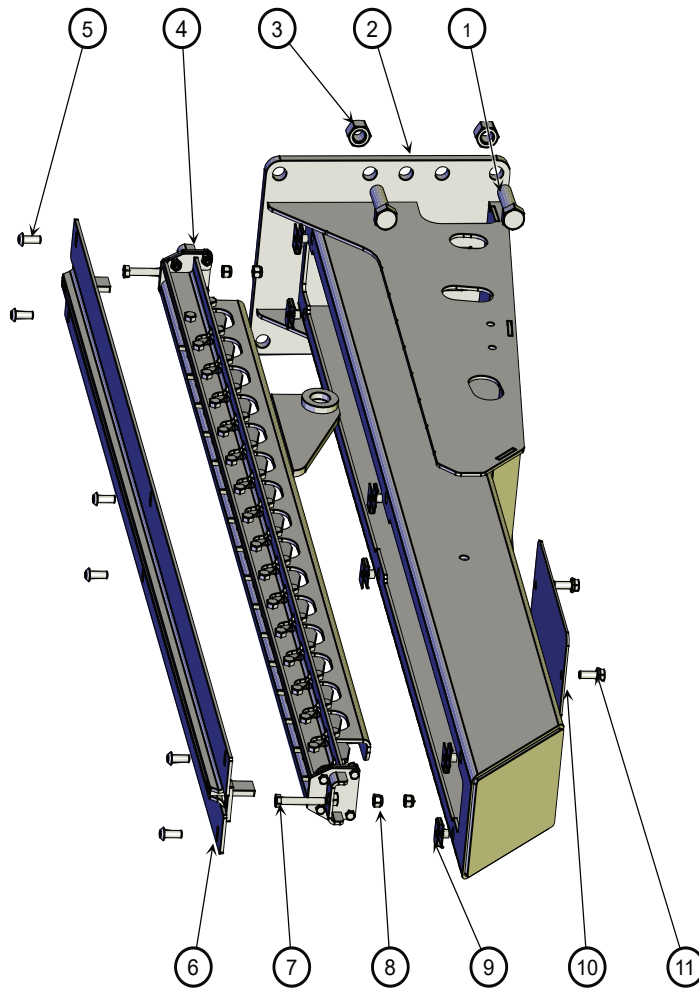

BOM ID	Part No.	Qty	Description
1	102.012.040	6	HC BOLT,HX,GR8 3/4-10X2-1/2"
2	1381871	1	ARM, 410
*NS	1381881	1	ARM, 510
3	188.012	4	NUT, HX,STV,GR8 3/4-10
4	1382031	4	HOOK CARTRIDGE, 410
*NS	1382181		HOOK CARTRIDGE, 510
5	257.006.016	1	SCREW, PHM, TX, 3/8-16 X 1"
6	252.006.040	2	BOLT,HX,TAP,GR5 3/8-16X2-1/2
7	187.006	1	NUT,HX,NYL,GR8 3/8
8	155993	8	U-NUT,TINNERMAN,EXTRUDED3/8-16
9	1382111	4	COVER, ARM ACCESS
10	111.006.016	2	BOLT,HX,FL,GR5 3/8-16X1
11	1365472	1	HOOK MOUNT, 410
*NS	1376921	1	HOOK MOUNT, 510

## Hook Cartridge

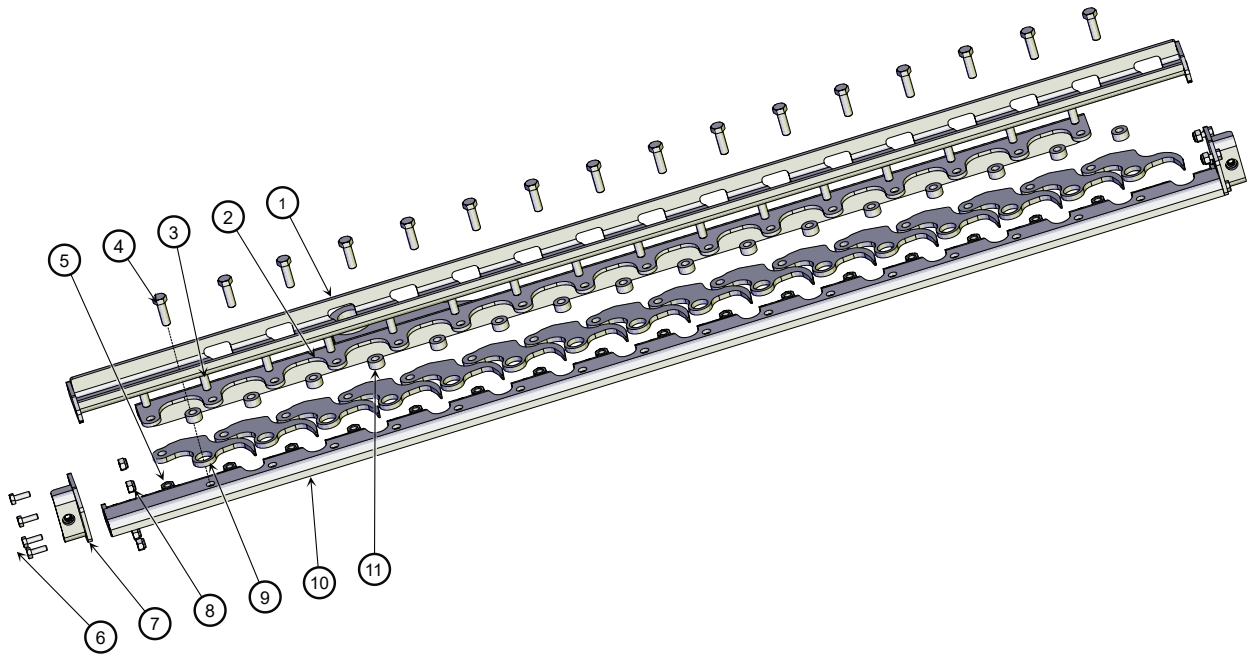

WTR410			
BOM ID	Part No.	Qty	Description
1	1382071	1	TOP CHANNEL, HOOK SUPPORT
2	1382001	1	ACTUATOR, HOOK,410
3	102.006.016	16	BOLT, HX, GR8 3/8-16X1
4	102.006.020	16	BOLT, HX, GR8 3/8-16 X 1-1/4"
5	187.006	32	NUT,HX,NYL,GR8 3/8
6	102.004.012	8	BOLT, HX, GR8 1/4-20 X 3/4"
7	1382041	2	END CAP, HOOK SUPPORT
8	187.004	8	NUT,HEX,NYLOCK 1/4-20 COARSE THREAD PLATED
9	1382611	16	HOOK,HEAVY DUTY
10	1382061	1	BOTTOM CHANNEL, HOOK SUPPORT 410
11	156082	16	SPACER, UNTHREADED ZINC PLATE 1/2" ID X 3/4" OD X 3/8"LONG
WTR510			
BOM ID	Part No.	Qty	Description
1	1382201	1	TOP CHANNEL, HOOK SUPPORT
2	1382171	1	ACTUATOR, HOOK,510
3	102.006.016	20	BOLT, HX, GR8 3/8-16X1
4	102.006.020	20	BOLT, HX, GR8 3/8-16 X 1-1/4"
5	187.006	40	NUT,HX,NYL,GR8 3/8
6	102.004.012	8	BOLT, HX, GR8 1/4-20 X 3/4"
7	1382041	2	END CAP, HOOK SUPPORT
8	187.004	8	NUT,HEX,NYLOCK 1/4-20 COARSE THREAD PLATED
9	1382611	20	HOOK,HEAVY DUTY
10	1382231	1	BOTTOM CHANNEL, HOOK SUPPORT 510
11	156082	20	SPACER, UNTHREADED ZINC PLATE 1/2" ID X 3/4" OD X 3/8"LONG

## Knife Arm

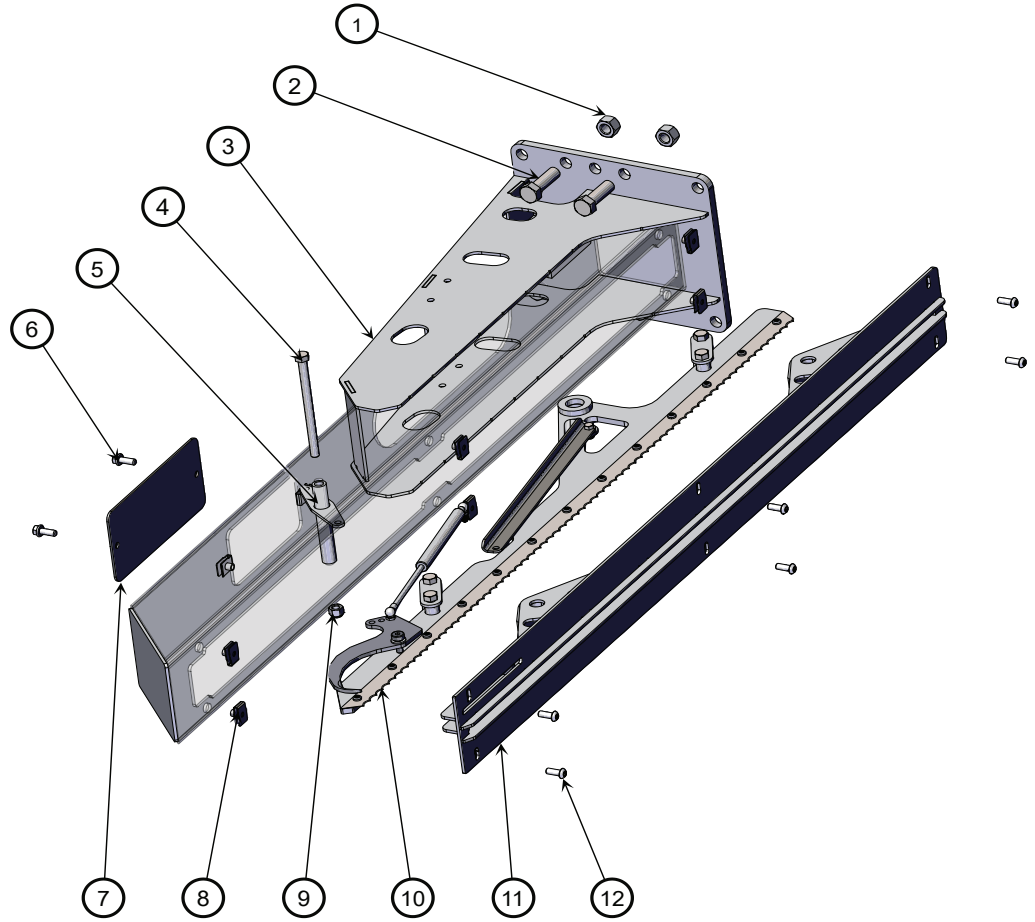

BOM ID	Part No.	Quantity	Description
1	188.012	4	NUT, HX,STV,GR8 3/4-10
2	102.012.040	4	HC BOLT,HX,GR8 3/4-10X2-1/2"
3	1381871	1	KNIFE ARM, 410
*NS	1382141	1	KNIFE ARM, 510
4	101.008.112	1	BOLT,HX,GR5 1/2-13 X 7
5	1381951	1	ROCKER, EDGE HOOK
6	111.006.016	2	BOLT,HX,FL,GR5 3/8-16X1
7	1382111	1	COVER, ARM ACCESS
8	155993	8	U-NUT,TINNERMAN,EXTRUDED 3/8-16
9	187.008	1	NUT,HX,NYL,GR8 1/2-13
10	1381971	1	HOLDER, KNIFE 410
*NS	1382161	1	HOLDER, KNIFE 510
11	1381291	1	KNIFE CARTRIDGE, 410
*NS	1381261	1	KNIFE CARTRIDGE, 510
12	257.006.016	6	SCREW, PHM, TX, 3/8-16 X 1"

# Knife Cartridge

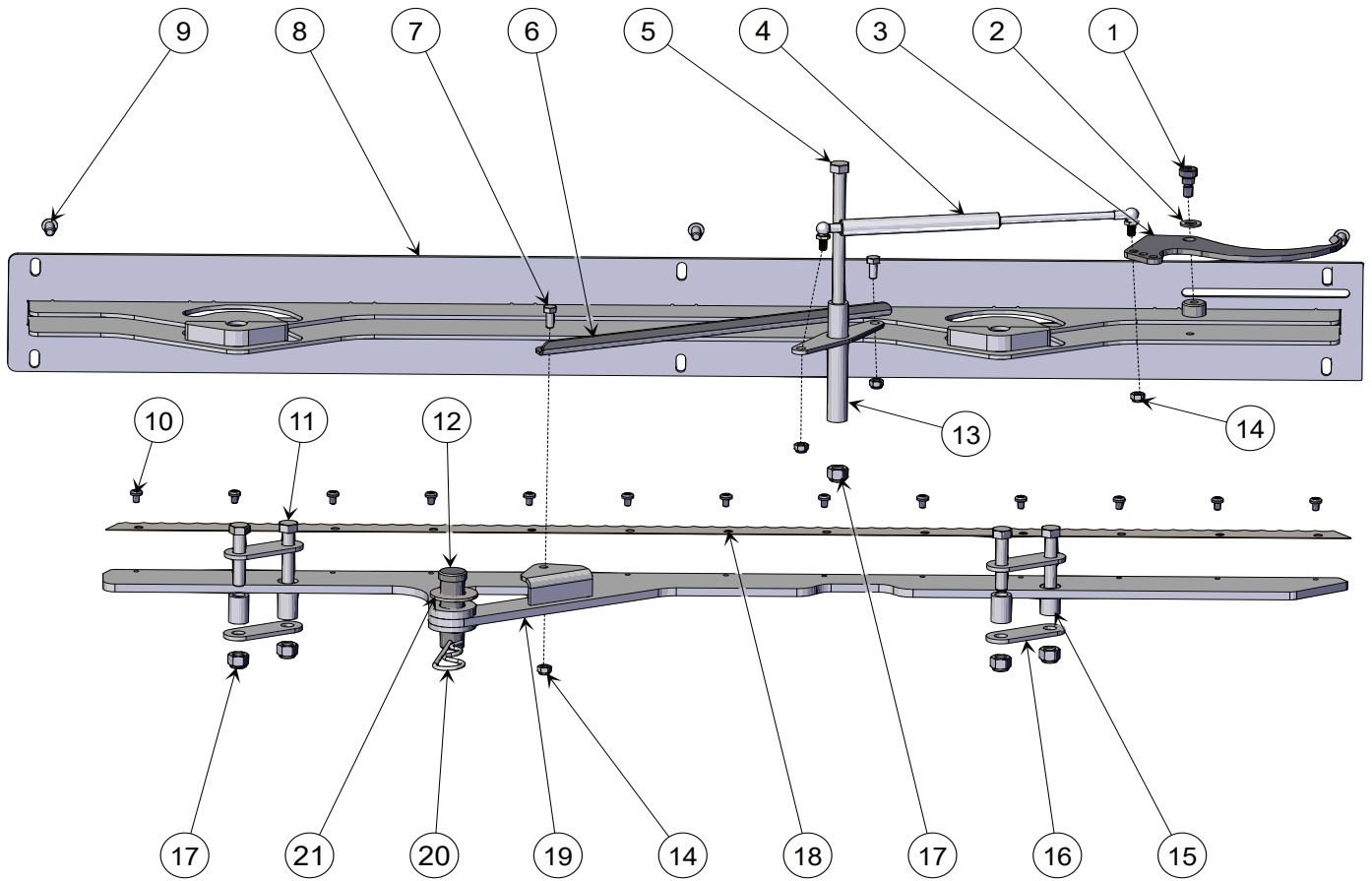

## Knife Cartridge

<b>WTR410</b>			
<b>BOM ID</b>	<b>Part No.</b>	<b>Qty</b>	<b>Description</b>
1	208.08.006	1	BOLT,SHL 1/2 X 3/8 SHLDR X 3/8-16 X 5/8 THD
2	162.014.008	1	BUSHING,MACH,NR,
3	1369602	1	EDGE HOOK
4	156081	1	GAS SPRING, 50 LBF, 13.19" EXTENDED X 4.92" STROKE
5	101.008.112	1	BOLT,HX,GR5 1/2-13X5-1/2
6	1381981	1	LINK, EDGE HOOK
7	102.005.012	2	BOLT,HX,GR8 5/16 -18X 3/4
8	1381291	1	KNIFE CARTRIDGE, 410
9	257.006.016	6	SCREW, PHM, TX, 3/8-16 X 1"
10	255.04.006	13	TX,SERR 1/4-20
11	102.008.040	4	BOLT,HX,GR8 1/2-13X2-1/2
12	156261	1	PIN, CYLINDER, 1 OD X 2-15/16 LONG
13	1381951	1	ROCKER, EDGE HOOK
14	187.005	4	NUT,HX,NYL,GR8 5/16
15	1369571	4	BUSHING, KNIFE PIVOT
16	1356093	4	KNIFE LINK
17	187.008	5	NUT,HX,NYL,GR8 1/2-13
18	156079	1	SAWBLADE, SCALLOP, SINGLE EDGE DOUBLE BEVEL,
19	1381971	1	HOLDER, KNIFE 410
20	262.016.00056	1	PIN,HAIR, COTTER 1OD X 3-1/2"
21	133.016	1	WASHER, L9 HD FLT 1"
<b>WTR510</b>			
<b>BOM ID</b>	<b>Part No.</b>	<b>Qty</b>	<b>Description</b>
1	208.08.006	1	BOLT,SHL 1/2 X 3/8 SHLDR X 3/8-16 X 5/8 THD
2	162.014.008	1	BUSHING,MACH,NR,
3	1369602	1	EDGE HOOK
4	156081	1	GAS SPRING, 50 LBF, 13.19" EXTENDED X 4.92" STROKE
5	101.008.112	1	BOLT,HX,GR5 1/2-13X5-1/2
6	1381981	1	LINK, EDGE HOOK
7	102.005.012	2	BOLT,HX,GR8 5/16 -18X 3/4
8	1381261	1	KNIFE CARTRIDGE, 510
9	257.006.016	6	SCREW, PHM, TX, 3/8-16 X 1"
10	255.04.006	16	TX,SERR 1/4-20
11	102.008.040	4	BOLT,HX,GR8 1/2-13X2-1/2
12	156261	1	PIN, CYLINDER, 1 OD X 2-15/16 LONG
13	1381951	1	ROCKER, EDGE HOOK
14	187.005	4	NUT,HX,NYL,GR8 5/16
15	1369571	4	BUSHING, KNIFE PIVOT
16	1356093	4	KNIFE LINK
17	187.008	5	NUT,HX,NYL,GR8 1/2-13
18	156018	1	SAWBLADE, SCALLOP, SINGLE EDGE DOUBLE BEVEL,
19	2382161	1	HOLDER, KNIFE 510
20	262.016.00056	1	PIN,HAIR, COTTER 1OD X 3-1/2"
21	133.016	1	WASHER, L9 HD FLT 1"

## Manifold

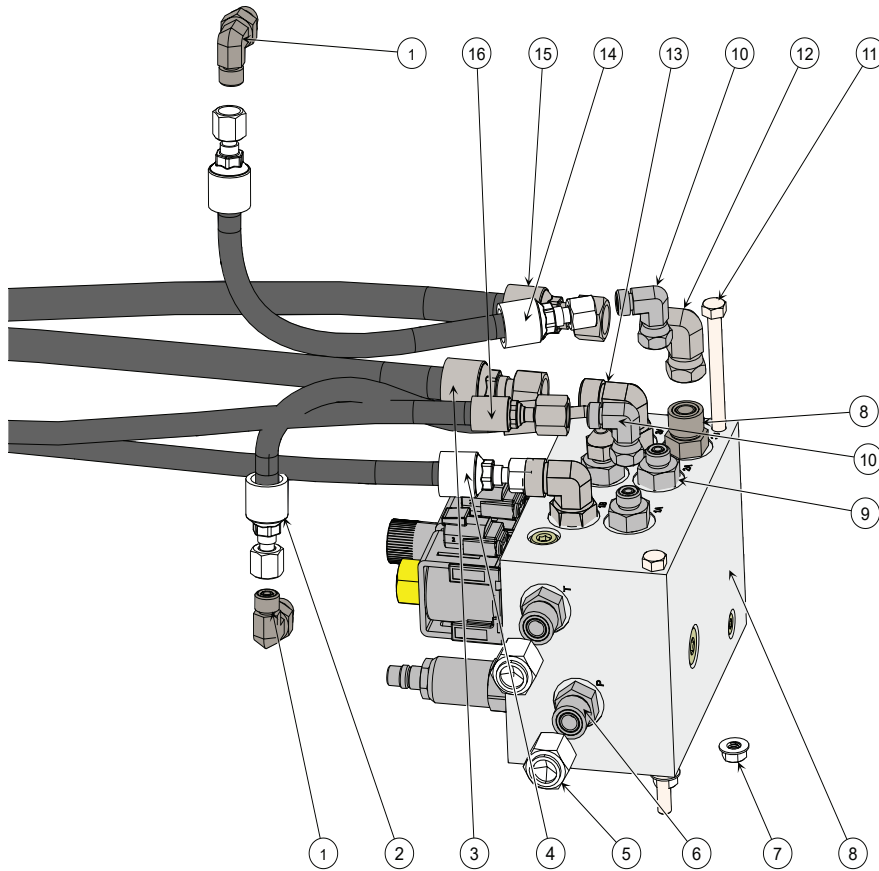

BOM ID	Hillco Part No.	Qty	Description
1	1003.06.04	2	HA, 90° -6MORB X -4MORFS
2	1383231	1	HOSE,GC387STANDARD,-04X13" -4FORS STR X -4FORS 90°
3	1383211	1	HOSE,GC387 STANDARD,-06X58" -8FORS STR X -8FORS 90°
4	1383261	1	HOSE, GC387 STANDARD,-04X60" -4FORS STR X -4FORS 90°
5	1068.08	2	CAP,-8FORFS
6	1001.08.08	2	STR -8MORB X -8MORFS
7	216.005	2	NUT, HX, FL, GR8 5/16-18
8	156225	1	MANIFOLD ASM, DIVERTER VALVE, WITH RELIEF & ORIFICE
9	1001.08.04	3	HYD, STR, -8MORB X -4MORS
10	1006.04.04	2	HA, 90°, -4FORS X -4MORS
11	102.005.096	2	BOLT,HX,GR8 5/16-18 X 6"
12	1006.06.06	1	HA,90° -6FORFS X -6MORFS
13	1003.08.06	4	HA,90° -8MORB X -6MORFS
14	1383241	1	HOSE, GC387STANDARD,-04X12" -4FORS STR X -4FORS STR
15	1383221	1	HOSE, GC387STANDARD,-06X63-1/2 -6FORS STR X -6FORS 90°
16	1383251	1	HOSE, GC387 STANDARD,-04X63" -6FORS STR X -6FORS 90°

## Hydraulic Junction

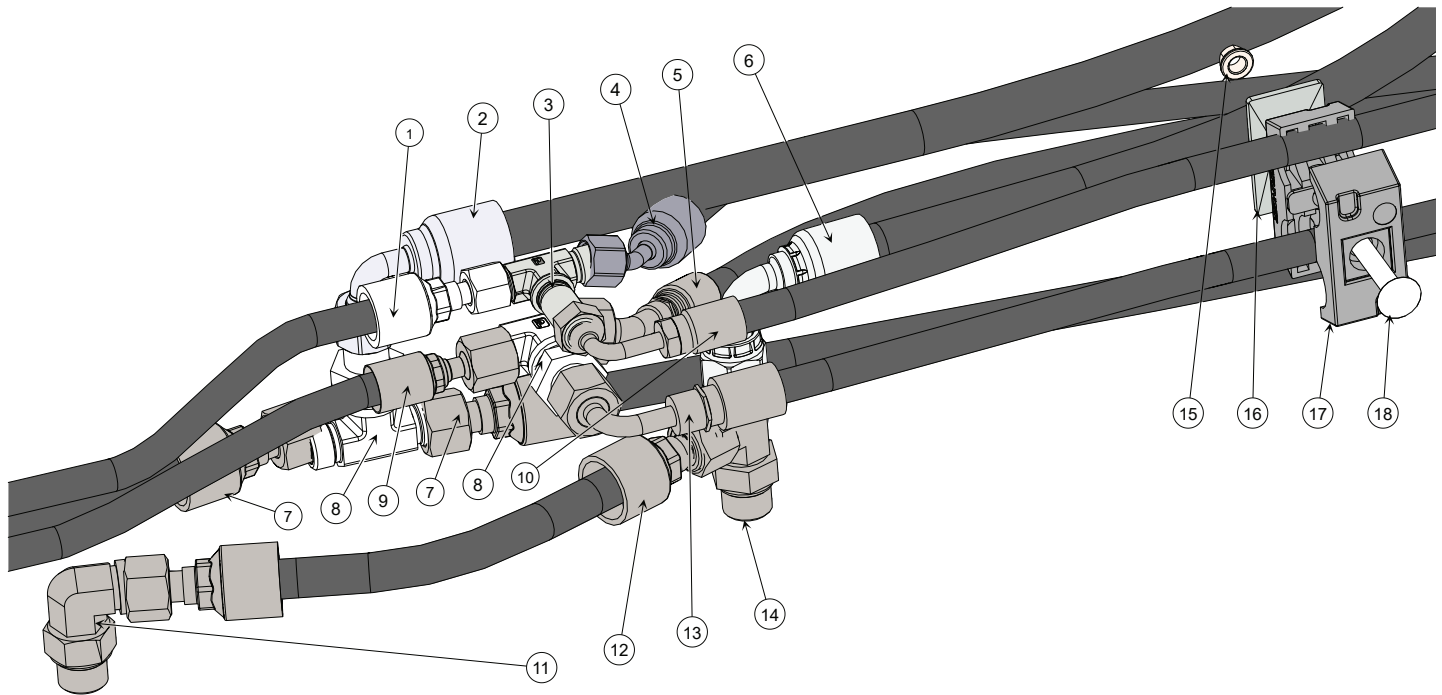

BOM ID	Part No.	Qty	Description
1	1383301	1	HOSE, GC387STANDARD,-04X79-1/2 -6FORS STR X -4FORS STR
2	1383221	1	HOSE, GC387STANDARD,-06X63-1/2 -6FORS STR X -6FORS 90°
3	1015.04	1	TEE, BKHD, BRA -4ORFS
4	1383281	1	HOSE, GC387 STANDARD,-04X77" -4FORS 45° X -4FORS STR
5	1383271	1	HOSE, GC387 STANDARD,-04X75" -6FORS 45° X -6FORS STR
6	1383211	1	HOSE, GC387 STANDARD,-06X58" -8FORS STR X -8FORS 90°
7	1379431	2	HOSE, 100R17AR -06 X 29" -6FORS STR X -8FORS STR
8	1015.06	2	TEE, BKHD, BRA -6ORFS
9	1383291	1	HOSE, GC387STANDARD,-04X82-1/2 -6FORS STR X -4FORS STR
10	1383261	1	HOSE, GC387 STANDARD,-04X60" -4FORS STR X -4FORS 90°
11	1003.08.06	1	90° -8MORB X -6MORFS
12	1367641	1	HOSE, 100R17AR -06X9-1/2",-6FORS STR X -8FORS STR
13	1383251	1	HOSE, GC387 STANDARD,-04X63" -6FORS STR X -6FORS 90°
14	1007.08	1	TEE STR, THD, RUN -8ORFS
15	119.005	1	NUT, HX, FL, SERR 5/16-18
16	139231	1	CLAMP, COVER PLATE
17	155531	1	CLAMP,TWIN, .500 DIAMETER
18	107.005.032	1	BOLT, CARR, GR5 5/16-18 X 2"

## Cylinders

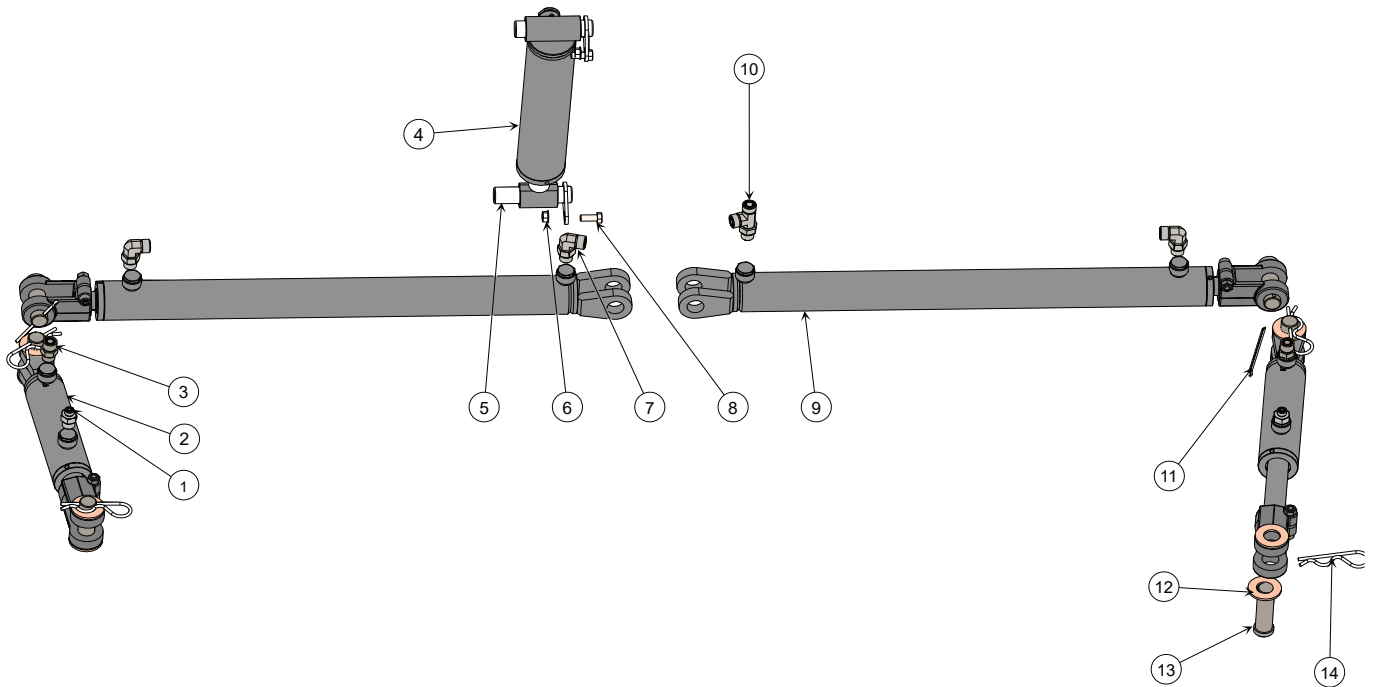

BOM ID	Part No.	Qty	Description
1	1001.08.04	2	STR, -8MORB X -4MORS
2	156378	2	CYLINDER, 2 X 4 X 1.25
3	1001.08.06	2	STR -8MORB X -6MORFS
4	156239	1	CYLINDER, CROSS TUBE, 2-1/2" B 1-1/4" ROD,8"STROKE, 16" CPC
5	1361752	2	PIN ROTATE CYL
6	216.006	2	NUT, HX, FL GR8 3/8-16
7	1003.08.06	3	90° -8MORB X -6MORFS
8	102.006.016	2	BOLT, HX, GR8 3/8-16X1
9	156086	2	CYLINDER, WTR, BORE 2" (OUTSIDE DIAMETER 2.38")
10	1007.08	1	TEE STR, THD, RUN -8ORFS
11	142.003.056	2	PIN, COTTER, 3/16 X 3-1/2
12	133.016	8	WASHER, L9 HD FLT 1"
13	156261	6	PIN, CYLINDER, 1OD X 2-15/16 L
14	262.016.00056	4	PIN,HAIR, COTTER 1OD X 3-1/2"

<b>Hydraulic Hose From-To Table</b>		
<b>Hose</b>	<b>From</b>	<b>To</b>
1383251	MANIFOLD 1A	LOWER TEE BRANCH
1383261	MANIFOLD 1B	UPPER TEE BRANCH
1383231	MANIFOLD 2B	ROTATE CYLINDER ROD
1383241	MANIFOLD 2A	ROTATE CYLINDER BASE
1379341	LOWER TEE RIGHT BRANCH	KNIFE CYLINDER ROD
1383291	UPPER TEE RIGHT BRANCH	KNIFE CYLINDER BASE
1383271	LOWER TEE LEFT BRANCH	HOOK CYLINDER BASE
1379431	UPPER TEE LEFT BRANCH	HOOK CYLINDER ROD
1383211	MANIFOLD 3A	CLAMP CYLINDER BASE TEE
1383221	MANIFOLD 3B	CLAMP CYLINDER ROD TEE

Decals

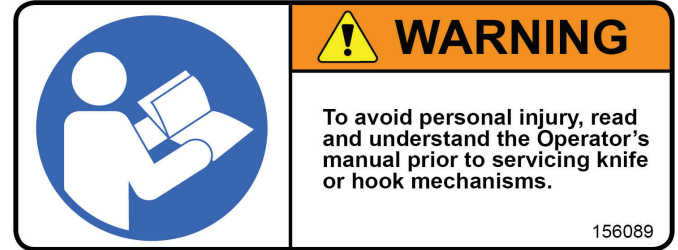

156209

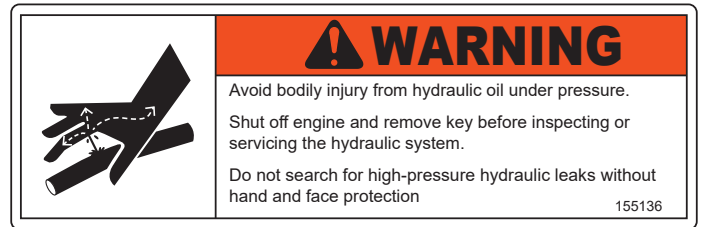

156210



156208



PART NO.	QTY.	DESCRIPTION
155136	1	DECAL, HYDRAULIC WARNING
155139	2	PINCH POINT DANGER
156008	2	DECAL, DANGER, WTR KNIFE
156088	1	DECAL, LOAD LIMIT
156089	2	DECAL, OPERATORS MANUAL
156047	1	WTR SWITCH BOX DECAL
156208	2	DECAL, HILLCO WTR
156209	2	DECAL, HILLCO WTR
1562010	1	DECAL, MADE IN AMERICA

## Electrical

<b>Part No.</b>	<b>Qty</b>	<b>Description</b>
114.#10.008	4	SCREW,PHM,CH 10-24X1/2
119.#10	4	NUT,HX,FL,SERR 10-24
1366311	1	SWITCH BOX HARNESS
1366321	1	MANIFOLD HARNESS
1366341	1	SWITCH BOX TO VALVE, 30FT
1367451	1	SWITCH POWER
153851	1	RAM 2-7/16" X 1-5/16" BASE W/ 1" BALL
155265	1	SWITCH BOX
156001	1	SWITCH, ROCKER DPDT, ON-OFF-ON
156002	1	SWITCH ACTUATOR, BLACK W/ RED LENS
156084	1	RAM HANDLEBAR U-BOLT BASE,1/2" TO 1-1/4" DIA
156085	1	RAM COMPOSITE DOUBLE SOCKET SWIVEL ARM
EC-145021	1	CIRCUIT BREAKER-TYPE 1, 12VDC, 8AMP

# Hydraulic Schematic

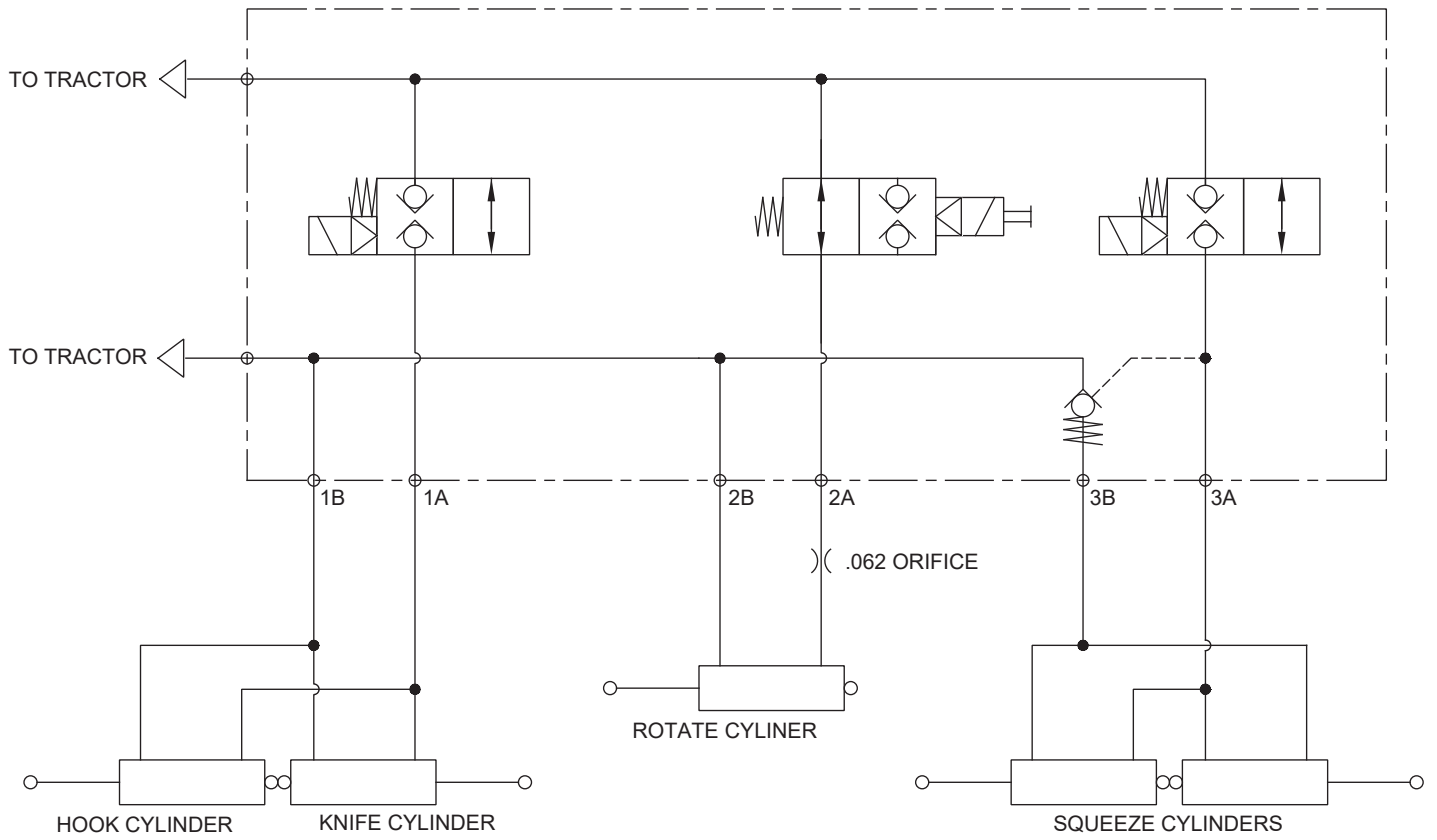

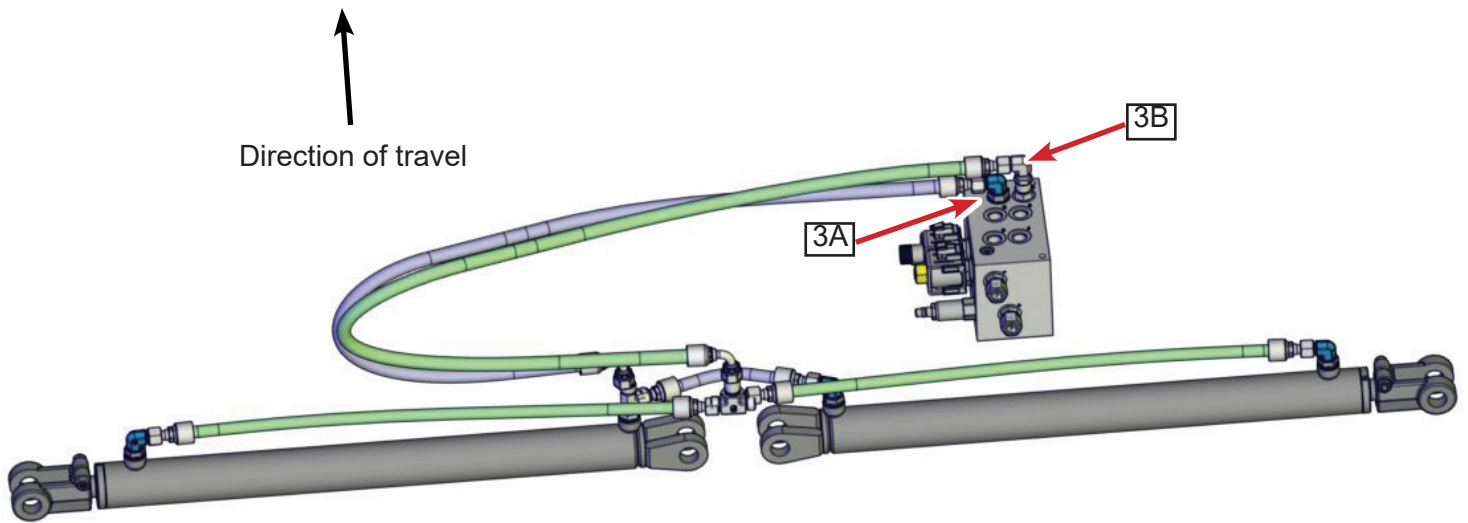

In the picture above, if the green hoses are pressurized, the reaction will be to retract the arms, squeezing the bale. If the purple hoses are pressurized, the reaction will be to extend the arms, releasing the bale.

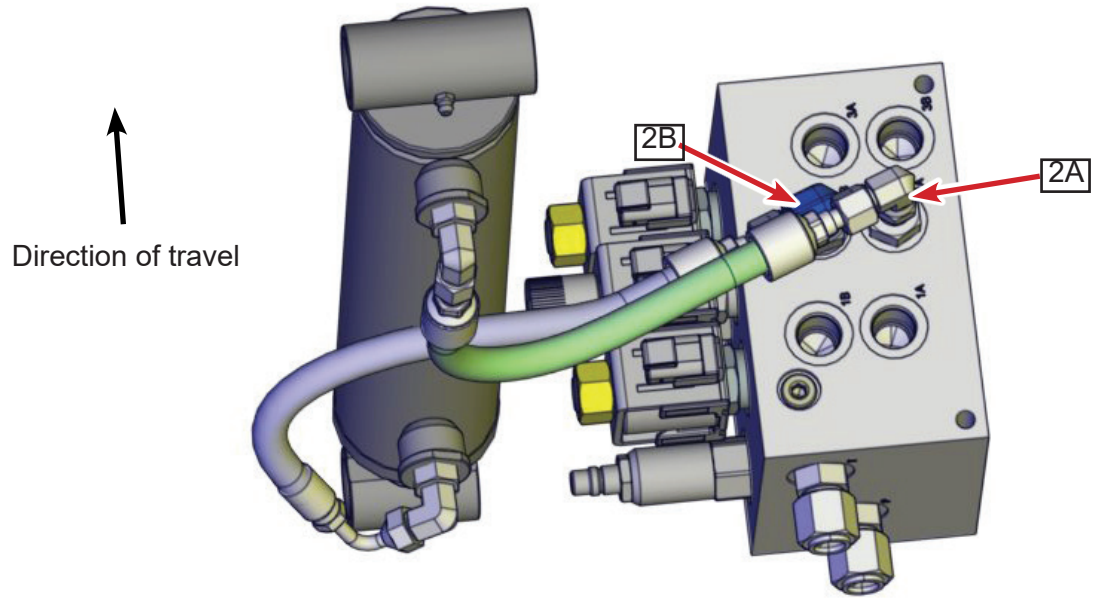

In the picture above, if the green hoses are pressurized, the arms will rotate up. If the purple hoses are pressurized, the arms will rotate down.

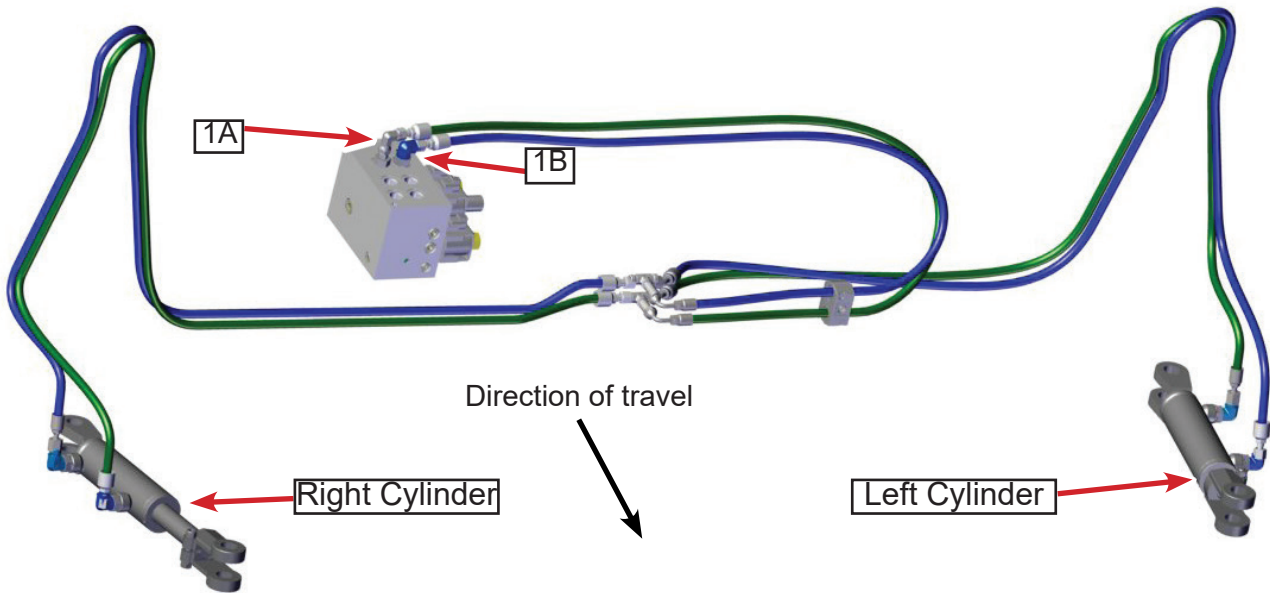

In the picture above, if the green hoses are pressurized, the left-hand cylinder will extend and the hooks will deploy, while at the same time the right-hand cylinder will retract, and the knife blade will cycle forward cutting the strings. If the cover edge hook is present, it will extend at this time. If the purple hoses are pressurized, the left-hand cylinder and hooks will retract, while at the same time the right-hand cylinder will extend, and the knife blade will cycle rearward. If the cover edge hook is present, it will retract at this time.

## Electrical Schematic

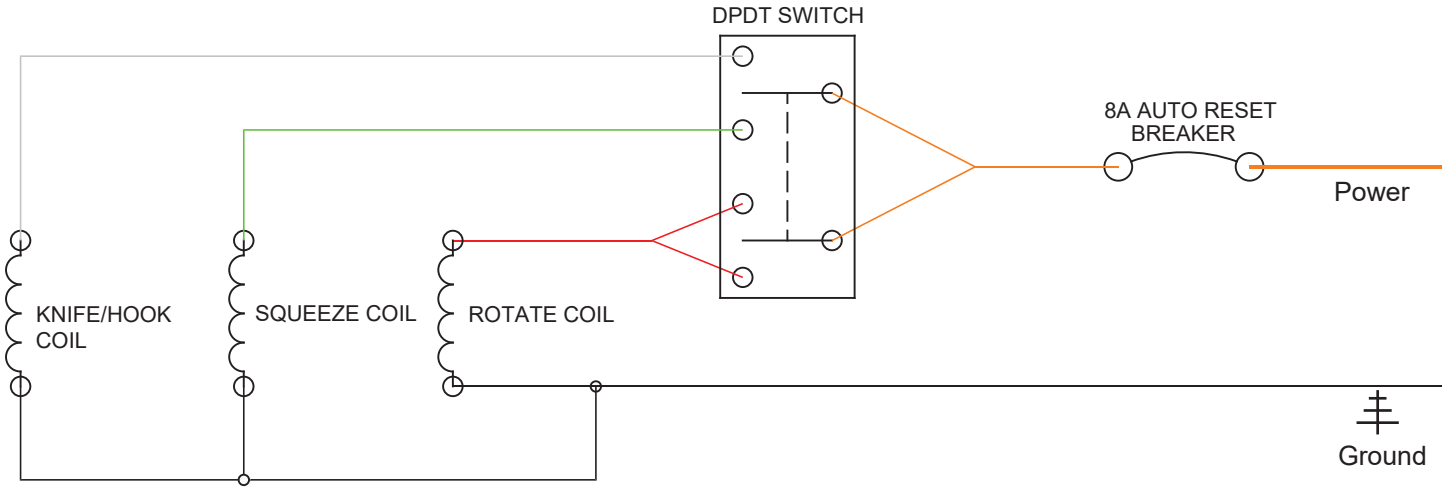

### Electrical Theory of Operation

When the switch is in the Rotate position (B), no power is supplied to any of the coils at the hydraulic manifold. Valves #1 and #3 are normally closed and valve #2 is normally open. When the switch is moved to the Squeeze Position (A), 12V power goes to both the Green and Red wires. The Green wire opens valve port #1 and the Red wire closes valve port #2 diverting oil flow to the Squeeze cylinders. When the switch is moved to the Cut/Grab position (C), 12V power goes to both the White and Red wires. The White wire opens valve port #3 and the red wire closes valve port #2 causing hydraulic flow to go to the Cut/Grab cylinders.

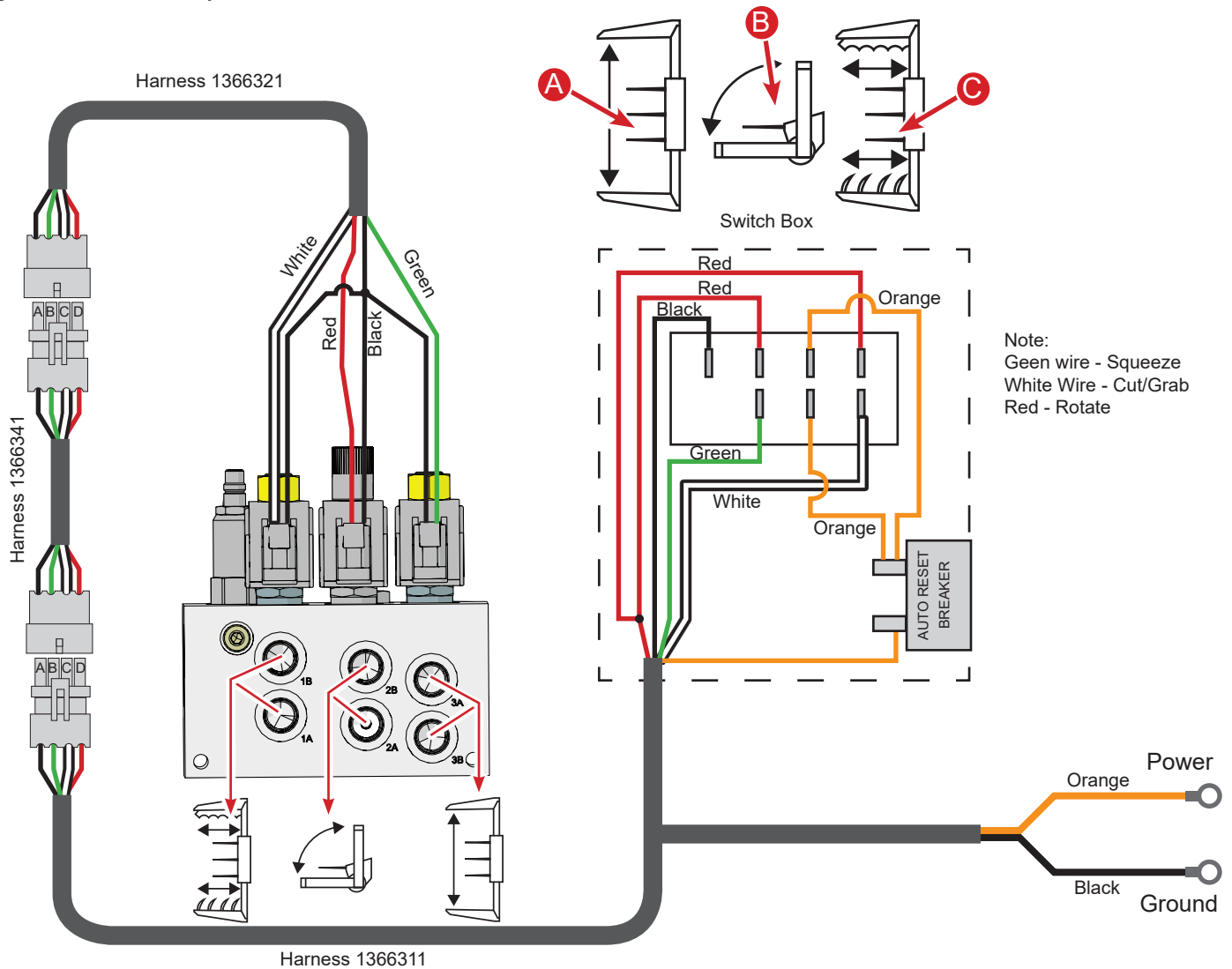

Trouble Shooting Guide		
Symptom	Probable Cause	Solution
Arms will not move in any switch position	Hydraulic oil is not being supplied to attachment	Check hydraulic connections between the attachment and tractor Check that tractor hydraulic system is functioning
Arms will not squeeze	No power to squeeze valve coil Hydraulic leak inside squeeze frame Debris in squeeze valve	Place switch into squeeze and check for 12v power on front coil (Green wire) Check all hoses for leaks or loose fittings Remove valve and inspect/clean
Attachment will not cut/grab	No power to cut valve on cut coil Hydraulic leak inside squeeze arms Debris in cut/grab valve	Place switch into squeeze and check for 12v power on rear coil (White wire) Check all hoses for leaks or loose fittings Remove valve and inspect/clean
Arms rotate in all switch positions	No power to switch box  No power to rotate valve on cut coil  Hydraulic leak between valve and rotate cylinder  Plugged rotate orifice Debris in rotate valve	Check for power to switch box, lights on switches should light up in cut/grab and squeeze positions  8A breaker inside box is tripped, cycle key power to reset  Place switch into cut or squeeze and check for 12v power on center coil (Red wire) Check all wiring for damaged or loose connections Check all hoses for leaks or loose fittings Remove orifice and inspect/clean Remove valve and inspect/clean
Edge hook will not deploy or retract with knife	Hook wedged inside arm  Broken or loose strut	Remove front access panel and inspect mechanism for debris or obstruction Remove front access panel and inspect
Squeeze arms move slowly or chatter	Air in cylinders  Debris in rotate valve	Lower loader to the ground and cycle squeeze arms fully several times Remove valve and inspect/clean
Hooks pull through netwrap	Netwrap is degraded over time	Adjust hooks outward to grab deeper into the bale
Hooks trap too much hay	Hooks are reaching excessively deep into bale	Adjust hooks inward to grab less hay
Knife stalls when cutting bale	Bale is wet/frozen  Knife blade is dull or damaged	Reduce clamp force slightly Cycle knife additional times Replace blade (See maintenance section for proper procedure)
Hooks stall when cutting bale	Bent or damaged hook binding inside arm  Hook actuator to hook bolts too tight	Replace damaged hooks (See maintenance section for proper procedure) Adjust tension on bolts (See maintenance section for proper procedure)
Knife misses outermost string on square bales	Twine is pulled tighter into bale than typical	Increase squeeze force  Install shim washers between outermost knife cartridge bolts and knife arm frame

