





# Operator's Manual

(SN25001-25999)

Model Year 2025

## Model SC1500 Specialty Crop Header

D-220415CMA01B

	 <b>WARNING</b>
	<p>Read and understand operator's manual prior to operating this equipment.</p> <p>Failure to follow operation instructions could result in personal injury or damage to the equipment.</p>

## Table of Contents

Warranty .....	3	Setup Screen .....	44
Safety .....	4	Limp Mode .....	44
Serial Number Tag .....	5	Notifications and System Alarms .....	45
Safety Labels .....	5	Pump .....	46
SC1500 Components .....	9	Output .....	46
Hydraulic Components .....	9	Automatic Pump Timer .....	46
Knockdown Bar .....	10	Crop Conditions Recommendations .....	47
Cutter Bar .....	10	Gauge Shoe Position .....	47
Converging Drums .....	11	Troubleshooting .....	48
Main Hydraulic Manifold .....	12	Theory of Operation .....	50
Drum Hydraulic Manifold .....	12	Platform .....	50
Drum Speed Sensor .....	12	Traction Unit .....	50
Height Gauge Shoes .....	13	Control System Overview .....	51
Air Dampeners .....	13	Sensor Inputs .....	51
Header Lockout .....	13	Drum Control .....	52
Hydraulic Pump .....	14	Hydraulic Pump .....	52
Hydraulic Filters .....	14	Main Hydraulic Manifold .....	52
Monitor .....	14	Hydraulic Motors .....	53
Encoder (Drum Speed Dial) .....	14	Platform Set-up Procedures .....	57
Controller .....	15	Calibration of Valves .....	59
Lights .....	15	Pressure Sensor .....	60
Wet Kit (If Equipped) .....	15	PWM Start .....	60
Front Console .....	16	PWM Max .....	60
Command Touch Cab Cornerpost .....	16	Lubrication and Maintenance .....	61
Multi-Function Lever .....	17	Grease .....	61
Attaching Platform .....	17	Cutterbar Oil .....	61
Balance Platform .....	22	Service Intervals .....	62
Prestart Checks .....	25	Daily Service .....	62
Break-in Rotary Platform .....	25	Every 10 Hours .....	63
Overview of the Operator's Manual .....	26	First 50 Hours .....	66
SC1500 Control Display Overview .....	27	Every 150 Hours/Yearly .....	70
Operation .....	28	Service .....	75
Monitor Mounting Locations .....	28	Hanging Drum Removal .....	75
Multi-Function Lever Operational Controls .....	29	Hanging Drum Repair .....	78
Raise and Lower Platform .....	29	Hanging Drum Installation .....	79
Adjust Cutterbar Angle .....	30	Replace End Disk Driver .....	82
Adjust Cutter Bar Speed .....	31	End Drum Install .....	85
Adjust Header Float PSI .....	31	Check Knives and Knife Bolts for wear .....	88
Header Automatic Controls .....	32	Remove and Install Knives .....	90
Monitor Operation .....	33	Replace Wear Cap .....	92
Home Screen Icons .....	34	Replace Crop Accelerator .....	93
Target Speed .....	34	Install and Synchronize Disks .....	94
Actual Speed .....	34	Electrical System Components .....	95
Solution Spray .....	34	Electrical Schematics & Harnesses .....	96
Output Power .....	34	Primary Wiring Harness .....	96
Lights .....	34	Manifold and Speed Sensor Harness .....	99
Home 1 .....	35	Light Harness .....	103
Home 2 .....	35	Cab Harness .....	105
Target Speeds of Drums .....	36	CAN Extension Harness .....	109
Knockdown Bar .....	37	Hydraulic Components & Schematic .....	112
Main Menu .....	38	Hydraulic Schematic .....	113
Options Menu .....	38	Notes .....	114
Data Menu .....	39		
Service .....	41		



# **Statement of Limited Warranty**

## **Class I Warranty**

### **Attached / Integrated Equipment, Parts, & Labor**

Hillco warrants its Class I products to be free from defects in material and workmanship for a period of twelve (12) consecutive months following the warranty start date.

The warranty start date for Hillco products invoiced by Hillco from October 1<sup>st</sup> through May 31<sup>st</sup> is the first day of June following the Hillco invoice date, or the first date of use, whichever is earliest. For Hillco products invoiced by Hillco from June 1<sup>st</sup> through September 30<sup>th</sup> the warranty start date is the date of invoice. Once the warranty period has begun, it cannot be stopped or interrupted.

Hillco warrants genuine Hillco replacement parts and components to be free from defects in material and workmanship for a period of ninety (90) consecutive days following the Hillco invoice date, or the remainder of the original equipment warranty period, whichever is longer.

Hillco's obligation under this product and parts warranty shall be limited to repairing or replacing, free of charge to the original purchaser, any part(s) that, in Hillco's judgment, shows evidence of such defect. Hillco additionally agrees to repair any physical damage to the product to which the Hillco product is directly attached provided that the damage is directly attributable to a defect in the design or manufacture of the Hillco product, as determined by Hillco, and that the damage occurs during the effective warranty period of the Hillco product.

### **Limitations to Warranty**

This warranty does not cover:

- 1) Any product damaged by accident, abuse, misuse, negligence, or improper maintenance.
- 2) Any unauthorized product alteration or modification.
- 3) Any unauthorized repairs made with parts other than genuine Hillco parts unless specifically authorized by Hillco.
- 4) Any repairs performed by anyone other than Hillco or an authorized Hillco dealer unless specifically authorized by Hillco.
- 5) Any claims directly resulting from improper installation, except those installations performed by Hillco.

### **Warranty Procedure**

No warranty claims will be accepted without a completed Dealer PDI on file at Hillco.

For warranty submission instructions please email [warranty@hillcotechnologies.com](mailto:warranty@hillcotechnologies.com) and request a Warranty Claim Form. Complete the Warranty claim form and submit the claim, via email to [warranty@hillcotechnologies.com](mailto:warranty@hillcotechnologies.com).

All warranty work must be performed, and claims submitted, within thirty (30) days of the occurrence of the claim and within the warranty period.

All parts removed during warranty repair should be held for a period of sixty (60) days after the warranty claim has been submitted to Hillco.

Hillco reserves the right to either inspect the product at the original retail purchaser's location, or the authorized Hillco's dealer's location; or require it to be returned to Hillco, transportation charges prepaid, for inspection.

For additional details on Hillco's Warranty Program refer to Hillco's current "Warranty Policy Guide".

### **Limitation of Liability**

Hillco makes no express warranties other than those, which are specifically described herein. Any description of the goods sold hereunder, including any reference to buyer's specifications and any descriptions in circulars and other media published by Hillco is for the sole purpose of identifying such goods and shall not create an express warranty that the goods shall conform to such description.

THIS WARRANTY IS EXPRESSLY IN LIEU OF ALL OTHER WARRANTIES EXPRESSED OR IMPLIED. There are no implied warranties of merchantability or fitness for a particular purpose. This warranty states Hillco's entire and exclusive liability and buyer's exclusive remedy for any claim for damages in connection with the sale or furnishing of Hillco products, their design, suitability for use, installation, operation, or for any claimed defects herein. HILLCO WILL IN NO EVENT BE LIABLE FOR ANY INCIDENTAL OR CONSEQUENTIAL DAMAGES WHATSOEVER, NOR FOR ANY SUM IN EXCESS OF THE PRICE RECEIVED FOR THE GOODS FOR WHICH LIABILITY IS CLAIMED.

Neither representative of Hillco nor any dealer associated with Hillco has the authority to change the items of this warranty in any manner whatsoever, and no assistance to purchaser by Hillco in the repair or operation of any Hillco product shall constitute a waiver of the conditions of this warranty, nor shall such assistance extend or revive it.

Hillco reserves the right to make improvements in design or changes in specifications at any time, without incurring any obligation to owners of units previously sold.

D-230314ADB01

## SAFETY ALERT SYMBOL



This Safety Alert symbol means  
**ATTENTION! BECOME ALERT! YOUR SAFETY IS INVOLVED!**

The Safety Alert symbol identifies important safety messages on the Hillco Leveling System and in the manual. When you see this symbol, be alert to the possibility of personal injury or death. Follow the instructions in the safety message.

## SIGNAL WORDS

Note the use of the signal words **DANGER**, **WARNING**, and **CAUTION** with the safety messages. The appropriate signal word for each message has been selected using the following guidelines:



**DANGER** - An immediate and specific hazard, which **WILL** result in severe personal injury or death if the proper precautions are not taken.



**WARNING** - A specific hazard or unsafe practice, which **COULD** result in severe personal injury or death if proper precautions are not taken.



**CAUTION** - Unsafe practices which **COULD** result in personal injury if proper practices are not taken, or as a reminder of good safety practices.



**NOTICE** - is used to address practices not related to physical injury.

## Serial Number Tag

The serial number tag is located on the left side of the platform (A).

Write down your Serial Number here for future reference.

SC1500- \_\_\_\_\_



## Safety Labels

Familiarize yourself with the location of all safety labels. Read them carefully to understand the safe operation of your machine.

### READ OPERATOR'S MANUAL SYMBOL

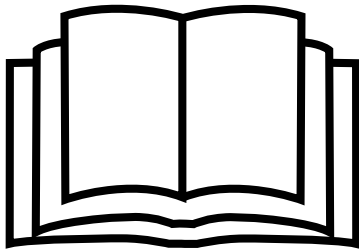

Decals, which display the Read Operator's Manual symbol, are intended to direct the operator to the Operator's Manual for further information regarding maintenance, adjustments and/or procedures for particular areas of the Leveling System. When a decal displays this symbol refer to the Operator's Manual for further instructions.

### TO APPLY NEW OR REPLACEMENT LABELS

1. Make sure the label area is smooth by removing any debris such as dirt or old labels.
2. Wash the area with soap and water and then dry it thoroughly.
3. After the area has completely dried, peel the backing off the safety label and place it onto the cleaned area.
4. Make sure all areas of the label have adhered to the machine by pressing down on the entire face of the label, including the corners.

(A)

**⚠️ WARNING**

Components behind guards or access doors in this area may rotate possibly several minutes, after power is shut off.

To avoid bodily injury:

1. Look and listen for evidence of rotation.
2. Do not open or move guard or access door until all components have stopped.

156041

Left Side of Platform



(B)

**⚠️ WARNING**

**AVOID INJURY FROM ROTATING KNIVES**

- Keep hands and feet away while machine is running
- Shut off power to service, lubricate or fold for transport.

156042

Right Side of Platform



(C)

**⚠️ DANGER**

Entanglement in rotating driveline can cause serious injury or death.

Keep all shields in place.

Avoid contact with rotating parts.

156045

Both Sides of Platform



(D)

**⚠️ WARNING**

Avoid serious injury from entanglement. Never raise shield with the engine running. Stop engine and remove key.

156046

(A)

Both Sides of Platform



(B)



(C)



Both Sides of Platform



**Hillco SC1500 Specialty Seed Crop Header**



**SC1500 Components  
Hydraulic Components**

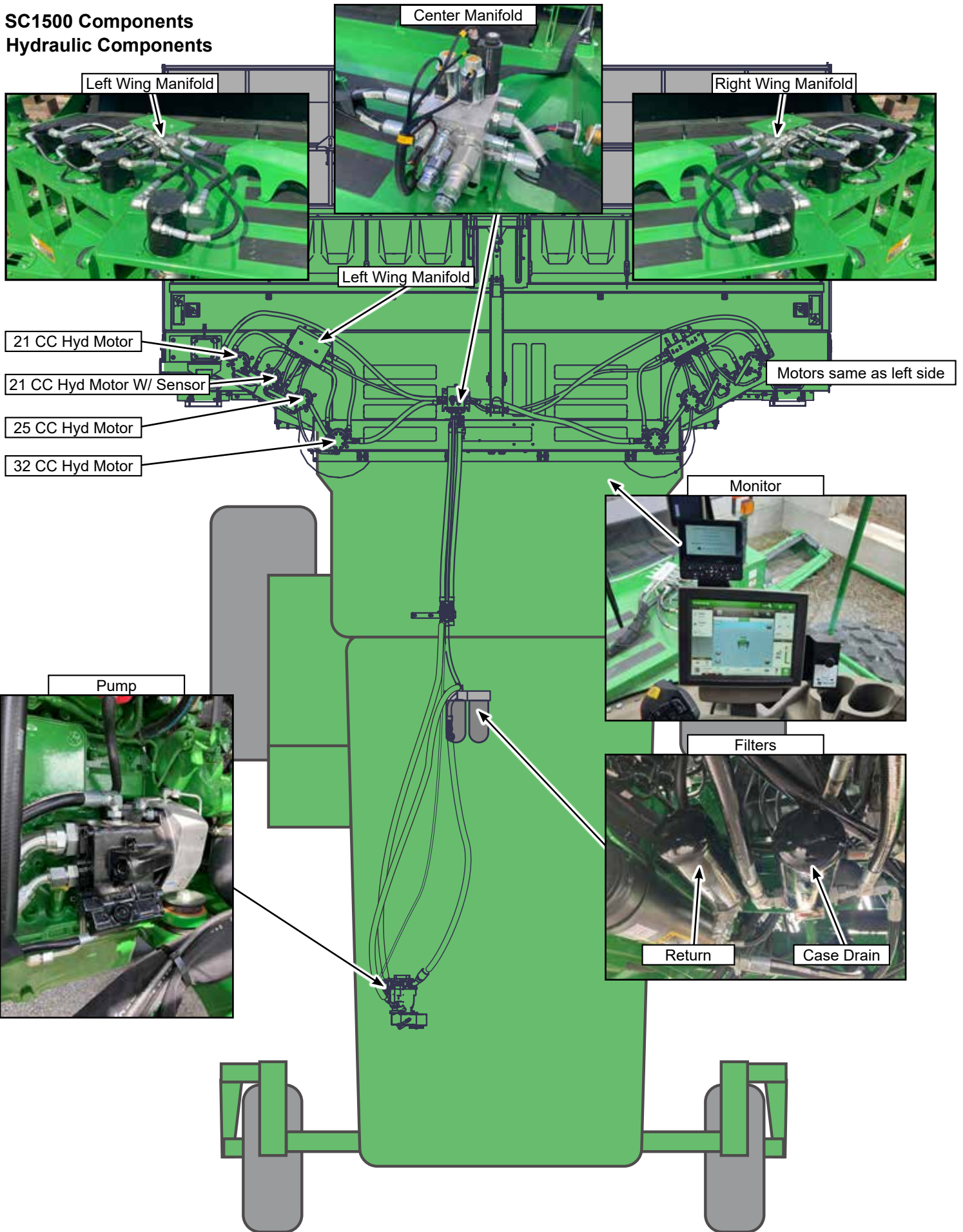

## SC1500 Components

### Knockdown Bar

The knockdown bar (A) assists in laying tall crops over so they feed better into the platform. The knockdown bar can be retracted back by a hydraulic cylinder. It is controlled through the SC1500 monitor.

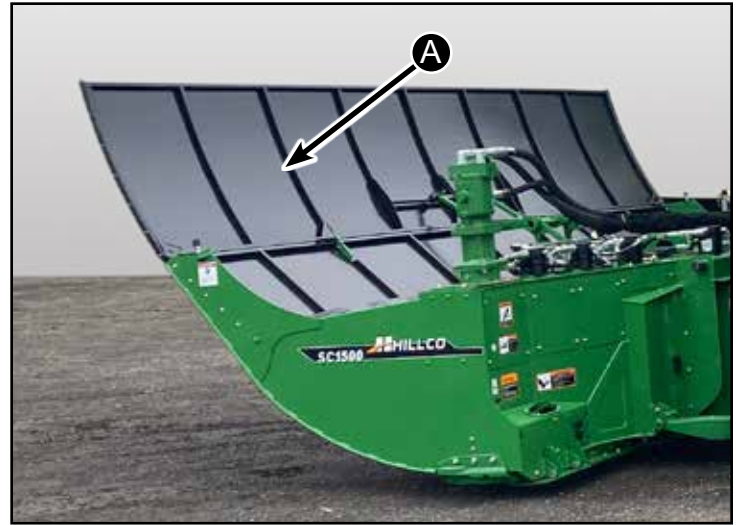

### Cutter Bar

The cutter bar (B) is composed of John Deere Components. The knives rotate towards the middle of the platform. Cutterbar is driven by traction unit motor from left side of platform.

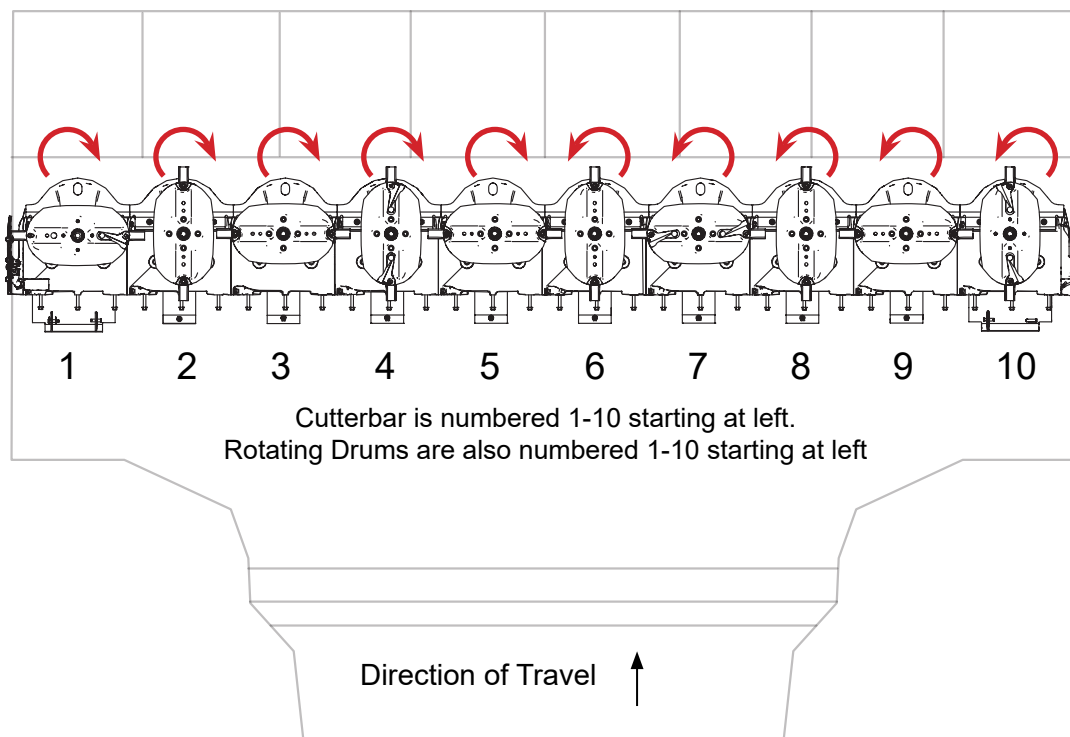

## Converging Drums

The converging drums rotate towards the middle directing the crop to the windrow. The drums are driven by hydraulic motors mounted to the top of the platform. For reference the drums are numbered left to right 1 through 10 as you sit in the cab.

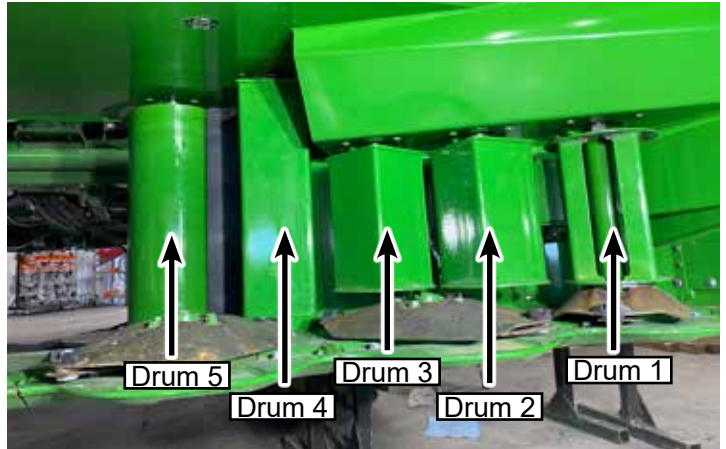
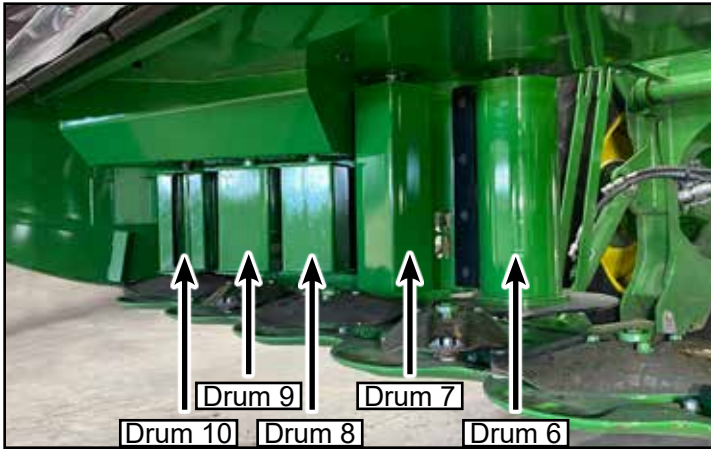

Top View of Platform

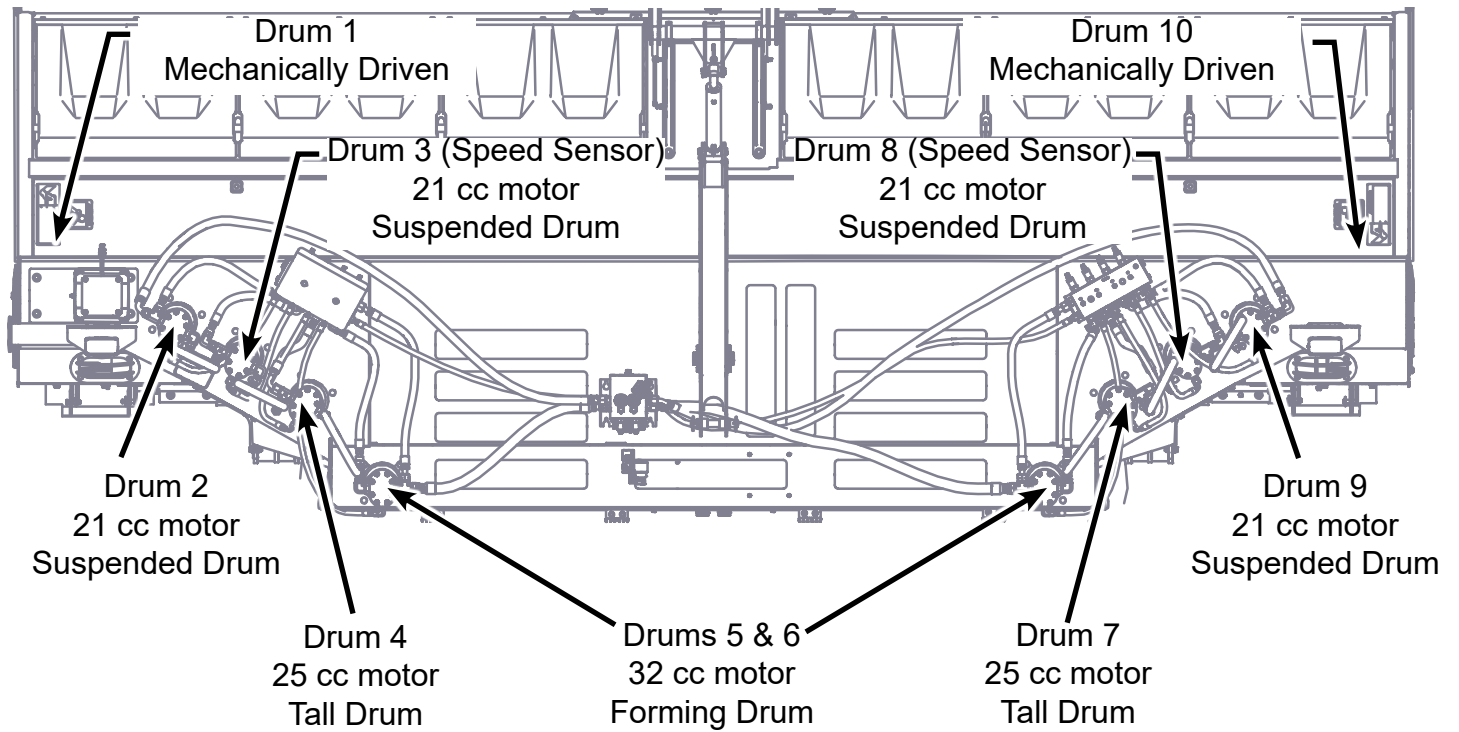

### Center Hydraulic Manifold

The center hydraulic manifold (A) is mounted to the middle of the platform. The hydraulic hoses and electrical quick couple into this manifold when connecting the platform to the traction unit. This manifold independently controls the speed to the left 2-5 motors and the right 6-9 motors. The manifold also controls the knockdown bar.

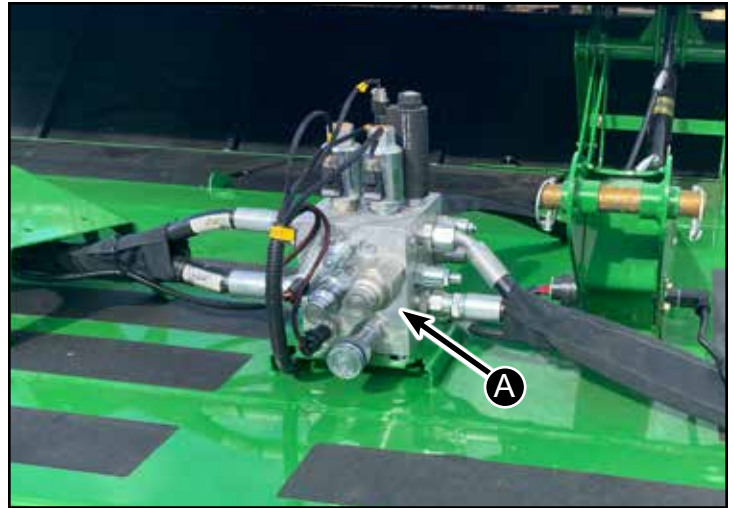

### Left & Right Hydraulic Manifolds

Each side of drums has a manifold (B) to divert oil to the motors. These manifolds provide cavitation protection and relief valve protection to the drive motors.

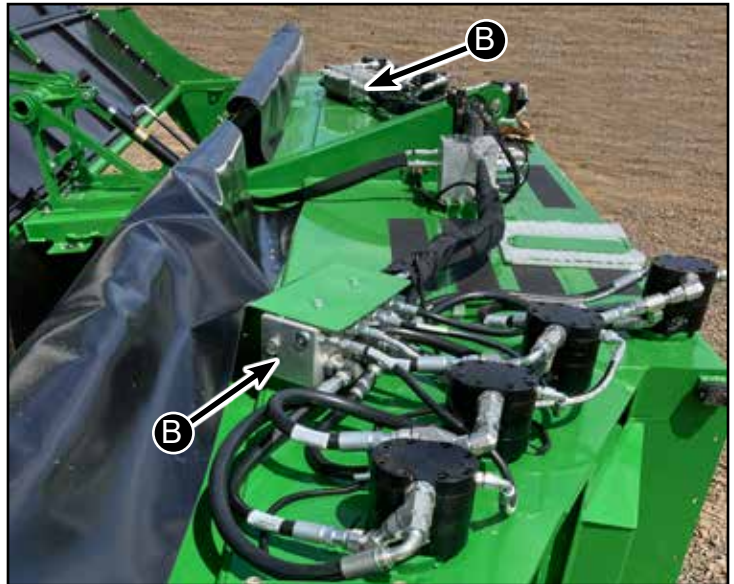

### Drum Speed Sensor

Motors 3 & 8 have a speed sensor (C) built into the housing of the motor. This speed is displayed on the monitor and used to provide a constant speed of the motors.



## Height Gauge Shoes

On each side of the platform are adjustable gauge shoes (A) to set the height of the back of the platform.

The mount for the adjustable gauge shoe (B) is replaceable in the event it becomes damaged.

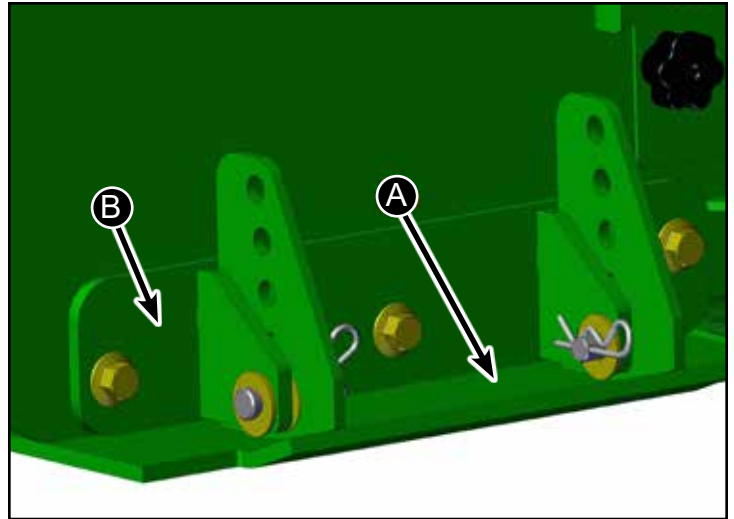

## Air Dampeners

Each side of the platform has adjustable dampeners for air flow.

Outer Dampener (C)

Inner Dampener (D)

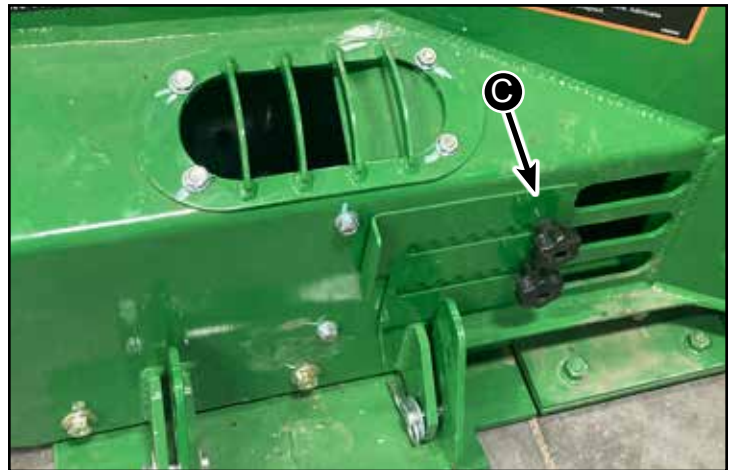

## Header Lockout

Traction unit is equipped with a safety lock to lock platform in the up position.

To lock the platform in the up position raise header all the way up. Lock pin holding platform up by moving lever (E) to lock position.



## Hydraulic Pump

On the auxiliary drive of the motor an axial piston pump (A) is installed. This is a closed center hydraulic pump with a load sense.

There are 4 hydraulic hoses connected to the pump. A suction hose, pressure hose, case drain hose and load sense hose.

The pump has a maximum flow of 27 gpm.

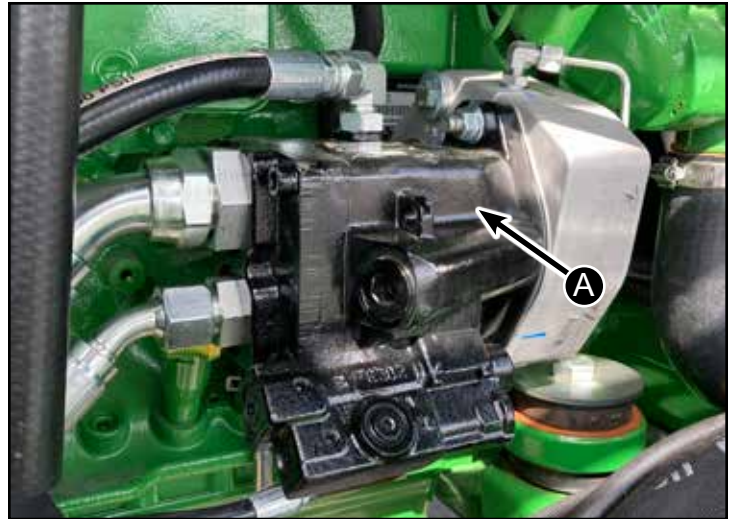

## Hydraulic Filters

Two hydraulic filters (B) are installed under the traction unit. One filter is for return oil from the platform. The other filter is for the case drain.

Part number for both filters is AH128449.

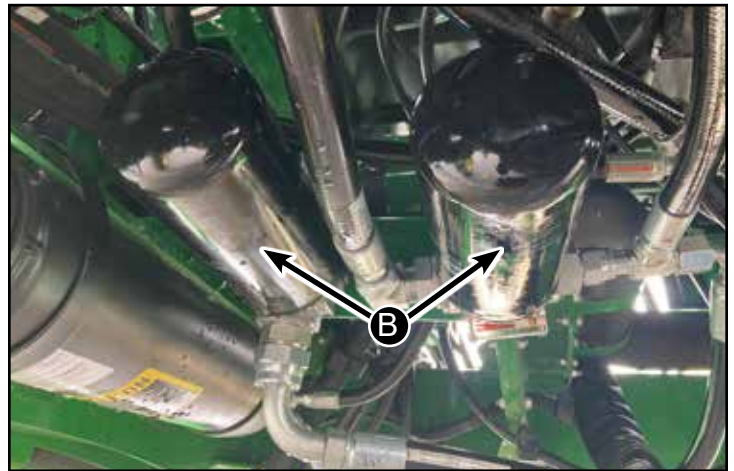

## Monitor

The SC1500 Monitor (C) is mounted to the traction unit monitor. The SC1500 monitor allows for operational adjustments, provides speed readouts and provides diagnostics. The Monitor can be relocated in the following positions.

Right of John Deere Monitor (C)

Above John Deere Monitor (D)

Left of John Deere Monitor (E)

See the Operation Section for more information on adjusting the monitor to the different locations.



## Encoder

Encoder dial (F) allows operator to speed up or slow down drums.

## Controller

The controller (A) for electrical functions is mounted on the platform behind a cover.

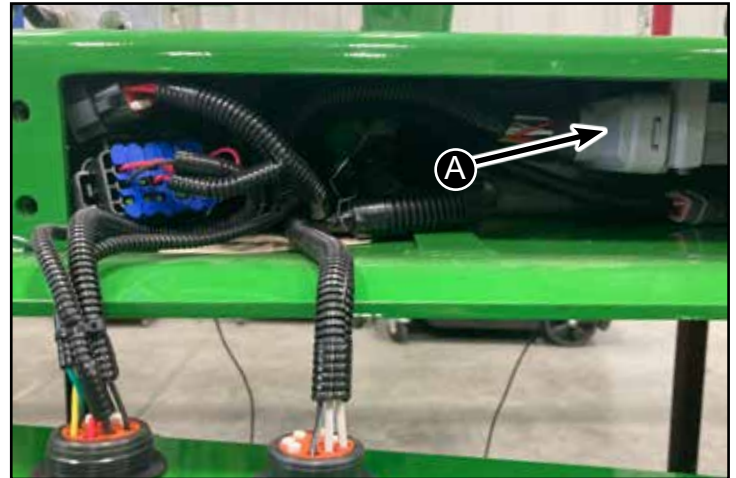
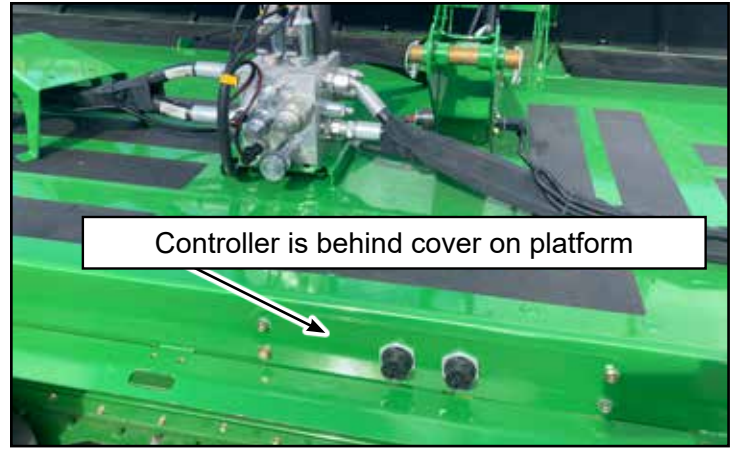

## Lights

There are lights on each side of the platform (B) that shine down lighting up the ground.

There are additional service lights under the platform that can be turned on when servicing the cutterbar.

All lights operate on the same circuit. They are controlled in SC1500 screen.

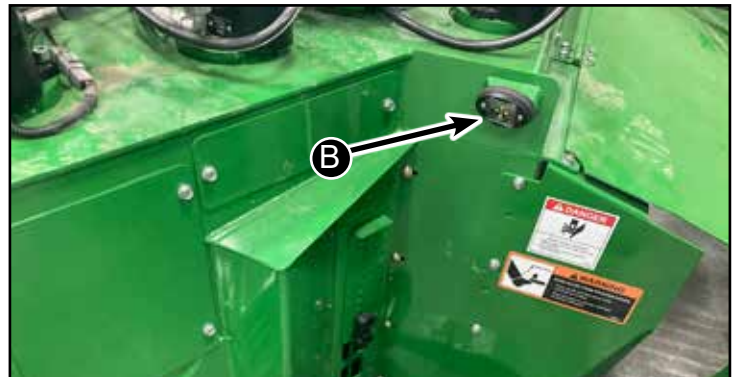

## Sprayer Kit (If Equipped)

See supplemental manual for Sprayer Kit set-up, nozzles (C), operation and parts.

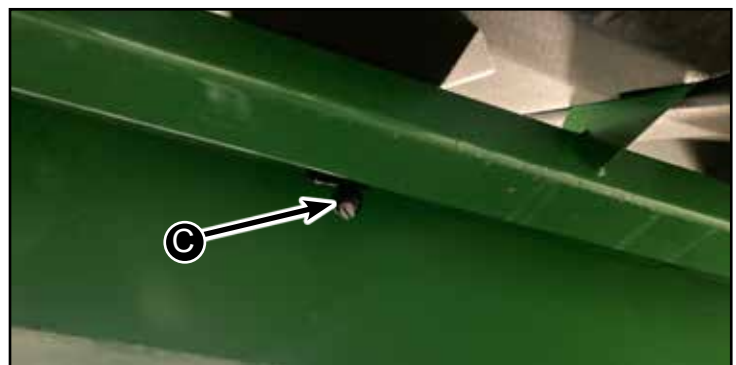

## Front Console

The left and right blinkers on the SC1500 are controlled with the blinker switch (B) on the front console.



## Command Touch Cab Cornerpost

Displays cutter bar speed (B) and header float pressure (C).



## Multi-Function Lever

The Multi-Function Lever (A) will control the following SC1500 functions

- Header Lift/Lower (B)
- Header Tilt (C)
- Cutterbar Speed (D)
- Header Float Pressure (E)

The Header Activation Buttons (F) can also control SC1500 functions for:

- Wet Kit on/off
- Output Auxiliary Power on/off

Additionally the Quick Stop Switch (G) will shut off all SC1500 systems.



## Attaching and Detaching Platform

### Attaching Platform

Follow prompts on the John Deere Screen.

(For Detaching Platform preform steps 1-24 in reverse order)

1. Sound horn and start machine engine.
2. Position machine next to platform.
3. Turn off machine.
4. With machine off turn on key and follow steps on Deere Monitor to release hydraulic pressure to lift mechanism.

From the Settings screen select Menu (A)

Select Calibrations and Pressures from the Menu Screen (B).

Select Header Pressure Release (C) and follow the instructions on the screen.

5. Remove hydraulic motor from left-hand lift arm and place motor on walkway outside of cab door.

6. If installed, remove hydraulic motor support from left-hand lift arm. Store support and cap screws.

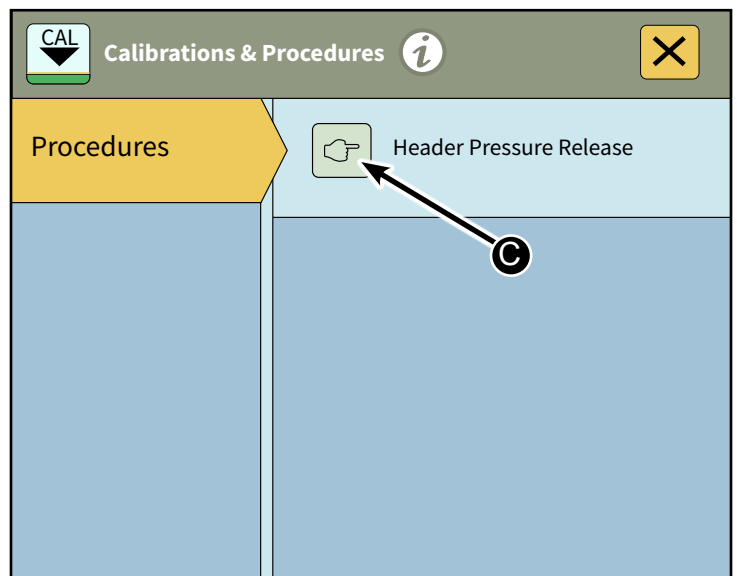
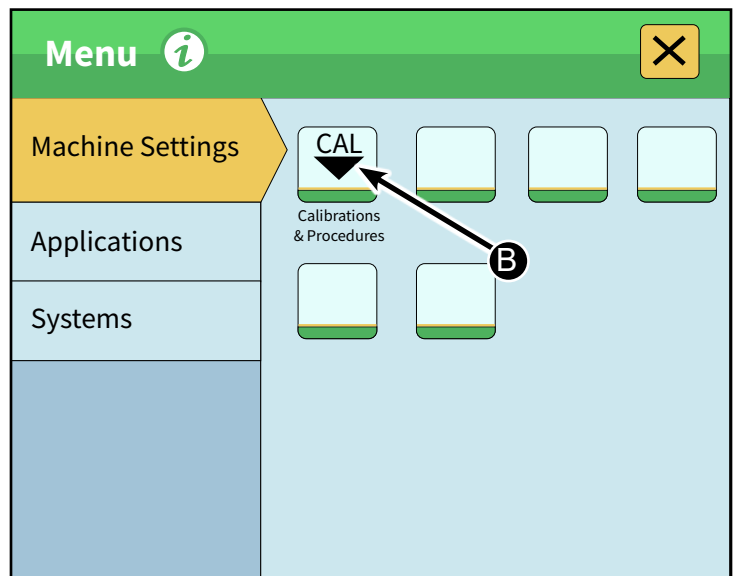
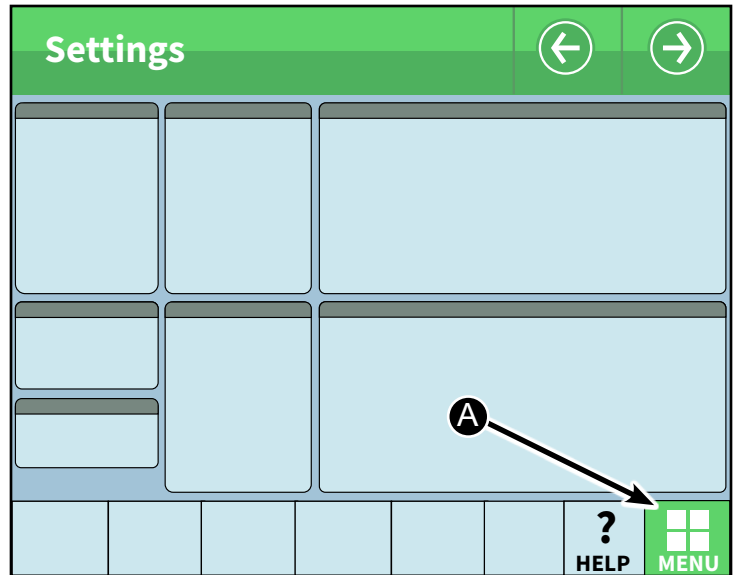

7. Position a support jack (A) under platform frame (B).

**⚠ DANGER**

Danger never engage platform with the center stand. Death and bodily injury can result

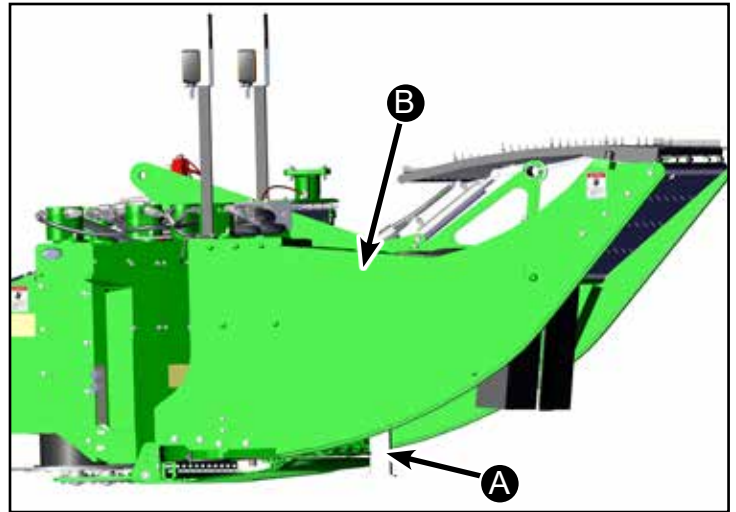

8. Remove pin (C), cap screw and lock nut (D) from both sides of machine.

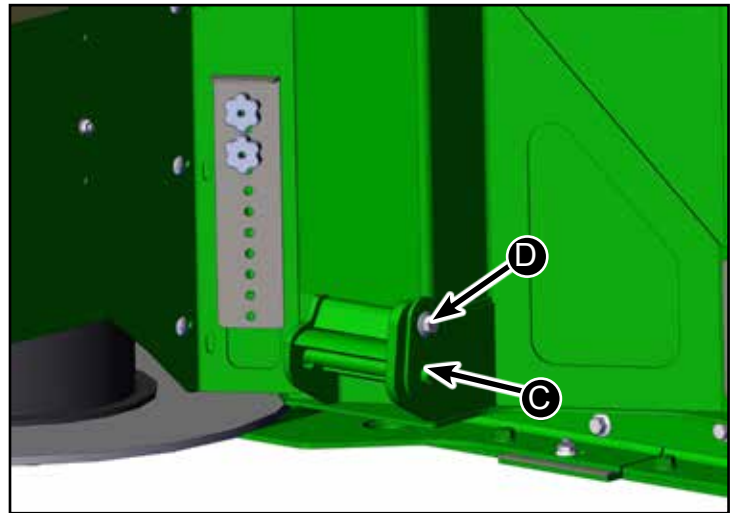

NOTE: To lower lift arms, it can be necessary to stand on lift arms when lowering.

9. Move lift arms (E) into position and raise arms into pockets on both sides of platform.

10. Turn off engine and remove key.

11. Install pin (F) and flange head cap screw, spacer, and locknut (G). Tighten flange head cap screw and lock nut to specification.



Specification

Lift Arm Flange Head

Cap Screw and Lock nut—Torque ..... 110 N·m  
(80 lb.-ft.)

12. If necessary, use a jack under front edge of platform to position platform when attaching to machine. If necessary, extend center link cylinder to line up with platform mounting hole.

13. Align center cylinder hole (A) with platform mount hole and install pin (B) and clip (C).

14. Connect wire harnesses (D) to connector on platform.

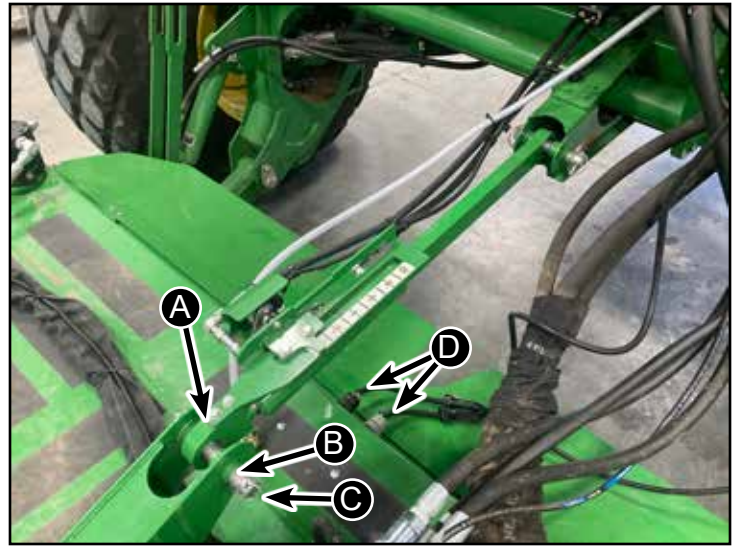

15. Remove and retain cap screws and nuts (E) and shield (F).

If equipped, store spacer nuts and shield in machine tool box.

Install motor with hydraulic hoses oriented toward center of platform.

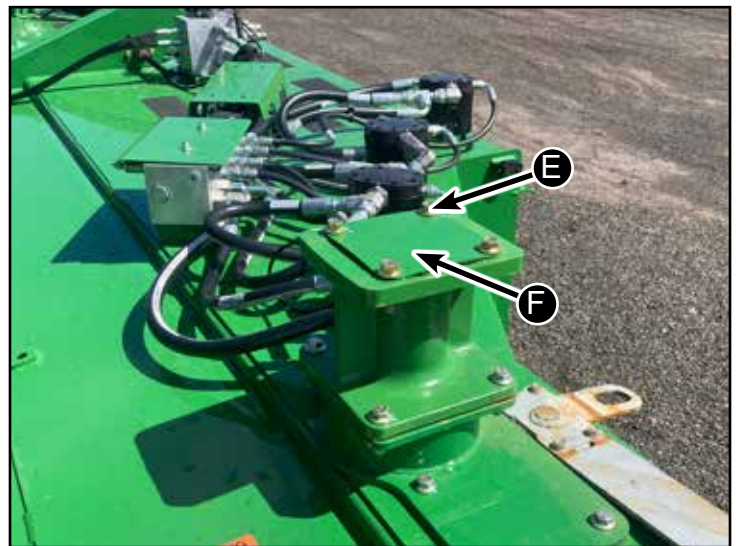

16. Apply anti-seize compound lubricant to splined shaft on motor, gear case shaft, and both ends of coupler.

17. Install motor (G) using existing cap screws (H). Tighten cap screws to specification.

Specification

Cap Screws—Torque .....95 N·m  
(70 lb.-ft.)

18. Loosen hose connectors (I). Allow hoses (J) to move into position taking any twists out of hoses. Tighten hose connectors to specification.

Specification

Hose Connectors Torque .....214 N·m  
(158 lb.-ft.)

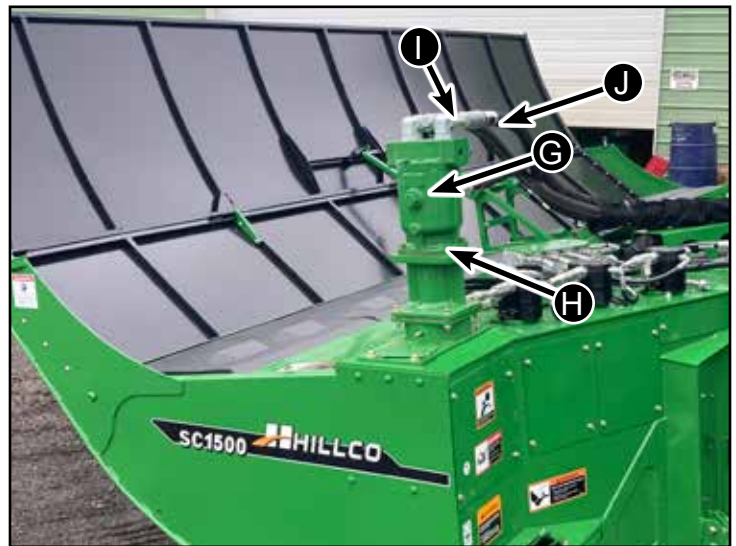

**IMPORTANT:** Reset float pressure before raising platform.

19. Connect the four hydraulic hoses (A) to the platform center manifold couplers (B). The hose ends only fit a certain way to where it is not possible to install them incorrectly.

20. Check platform balance. (See Balance Platform Side-To-Side in this section.)

21. Set platform float. (See John Deere Operator's Manual for procedure.)

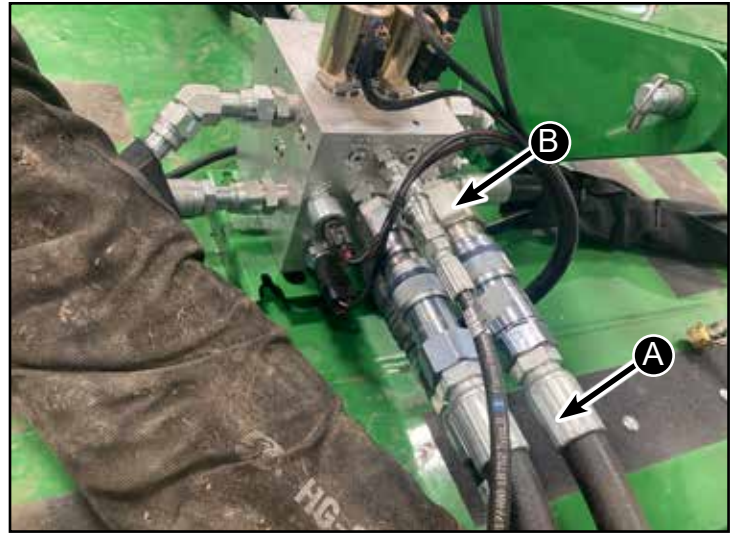

22. Lift platform all the way up and lock safety pin (B).

23. Shut off traction unit and remove key.



24. Remove front stand (C).

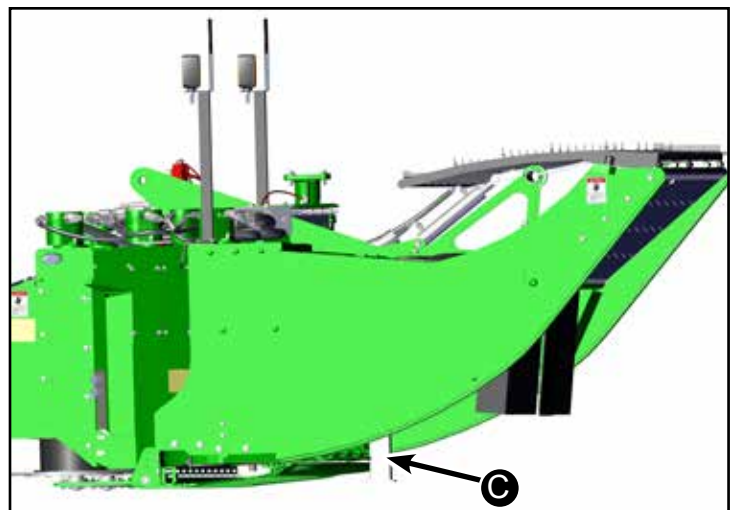

**CAUTION**

When raising platform for service or transporting, always engage platform lift lockout lever (B).

**DANGER**

Danger never engage platform with the center stand. Death and bodily injury can result

## Balance Platform

1. Sound horn and start machine engine.
2. Disengage header lockout lever and lower header to the ground. Turn off Machine engine.
3. Turn key to ON Position.
4. Navigate to the Calibrations and Procedures in the Machine Settings Tab.

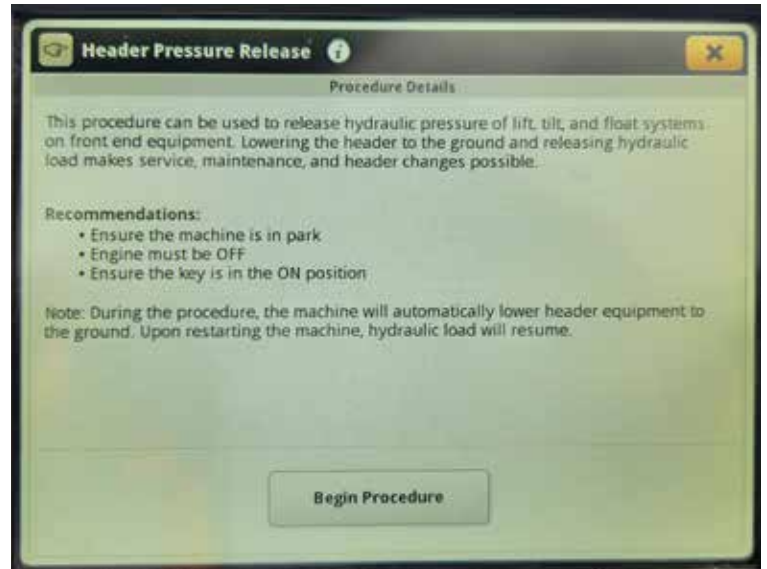
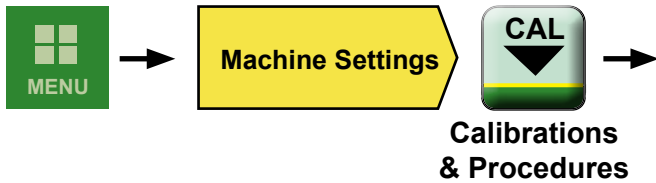

5. Select Header Pressure Release
6. Follow Instructions shown on display to release float pressure.

*NOTE: Balance on each side of header is adjusted by moving float cylinder to different holes in mounting brackets.*

*If two sides differ in weight by more than 27 kg (60 lb), readjust float cylinder location on the side that is lighter. Move float cylinder down one hole.*

Position left-hand and right-hand float cylinder at 3 Hole.

The #3 hole is the standard position for the SC1500 platform.

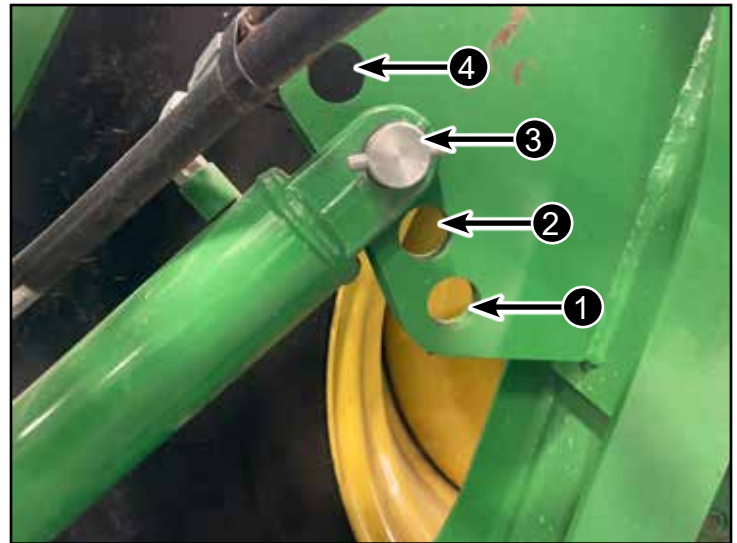

7. Sound horn and start machine engine.
8. Enable float adjustment by pressing (any directional button) float pressure adjust switch (A) on multi-function lever or pressing float pressure adjust switch (B).

Float pressure adjustment screen on CommandARM displays.



9. Raise platform off the ground using float pressure adjustment interface:

a. Touch plus (+) or minus (-) symbols (C and B) to increase or decrease float pressure of respective selection (L, AVG, or R)

b. Each press of plus (+) or minus (-) symbols on Float Pressure screen increases or decreases respective pressure in target increments of 10 psi.

c. Note which end of the platform is highest off the ground.

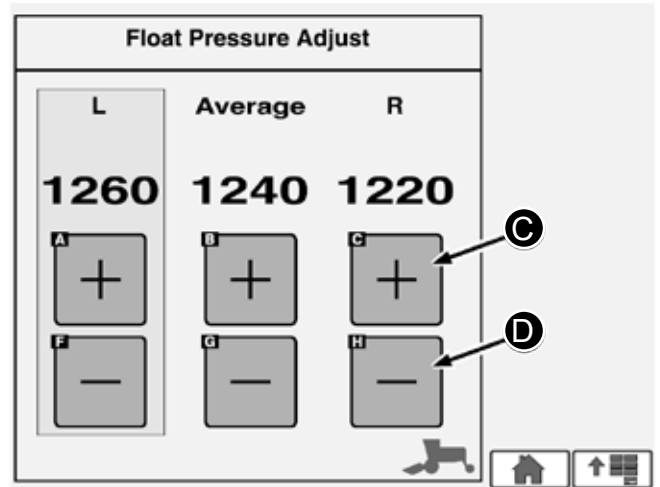

10. Raise platform off the ground using the pressure control dial:

a. Rotate pressure control dial (E) clockwise and counterclockwise to increase or decrease float pressure for highlighted selection on Float Pressure screen: L, AVG, or R.

b. Only one selection (L, AVG, R) can be adjusted at once, simultaneous adjustment of selections is not permitted.

c. Pressing float pressure adjust switch on CommandARM toggles between highlighted selections (L, AVG, or R) on Float Pressure screen.

d. Each rotational click of control dial increases or decreases respective pressure in target increments of 10 psi.

e. Note which end of the platform is highest off the ground.



11. Raise platform off the ground using the reel adjust quad:

a. Pressing UP arrow button (A) increases float pressure of highlighted selection (L, AVG, or R) on Float Pressure screen.

b. Pressing DOWN arrow button (B) decreases float pressure of highlighted selection (L, AVG, or R) on Float Pressure screen.

c. Only one selection (L, AVG, R) can be adjusted at once, simultaneous adjustment of selections is not permitted.

d. Pressing LEFT arrow button (C) or RIGHT arrow button (D) toggles between highlighted selections (L, AVG, or R) on Float Pressure screen.

e. Each pressing of reel adjust quad increases or decreases respective pressure in target increments of 10 psi.

f. Note which end of the platform is highest off the ground.



12. Lower platform to the ground using the adjustment interface, pressure control dial, or reel adjust quad. If platform is balanced (both sides raise and lower evenly), adjust platform float. (See Adjust Platform Float in Operating Platform section.)

13. If platform is NOT balanced, perform the following:

- a. Turn off engine and turn key to ON position.
- b. From Windrower Main page, touch or press confirm switch when Platform Setup icon is highlighted to advance to next display screen.
- c. Touch or press confirm switch when Connect icon (E) is highlighted to advance to next display screen.
- d. Follow instructions shown on display to release float pressure.

e. Place cylinder on high side into a lower hole.

14. Sound horn and start machine engine.

15. To raise platform off the ground, repeat Steps 9—11.

16. Repeat procedure until both sides of platform raise and lower evenly.

17. Adjust platform float. (See Adjust Platform Float in Operating Platform section.)

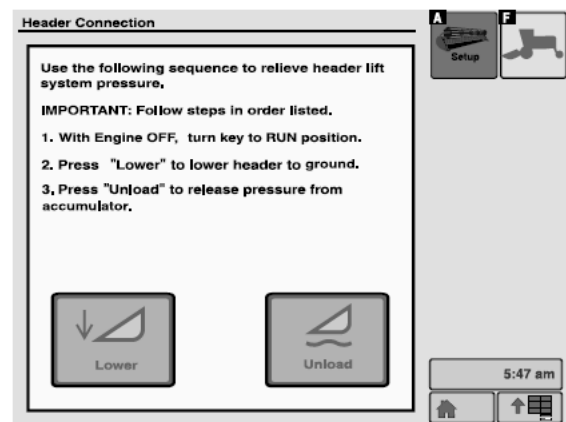
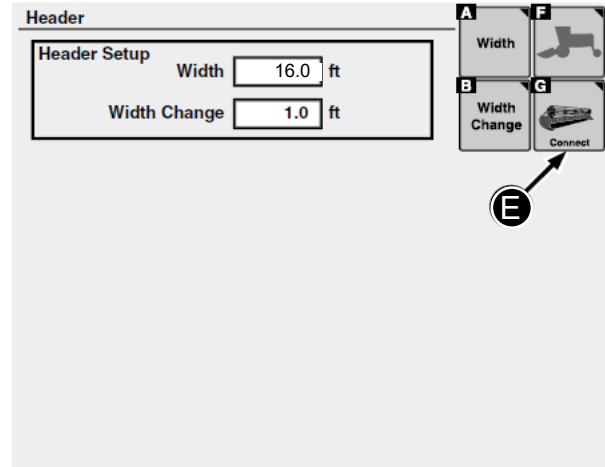

## Prestart Checks

Inspect and service machine before starting work each day.

1. Clean cutterbar.
2. Check disk wear. (See Check Knife Wear in Service section.)
3. Check knives; reverse or replace if knives are blunt.  
(See Check Knives in Service section.)
4. Check that knives are correctly positioned.
5. Check that knives rotate freely.
6. Check for any loose bolts and missing hardware.
7. Check platform lift, cutting angle, and float.
8. Inspect drum bearings.
9. Check Drum Drive shaft and Lovejoy couplers.
10. Lubricate Drum Drive shaft (See Service Interval section for more information)

## Break-in Rotary Platform

1. Lower platform to ground.
2. Run windrower empty at slow idle speed for 15 minutes. Disengage platform drive, turn off windrower engine, and inspect platform.
3. Run windrower at rated speed for 15 minutes. Disengage platform drive, turn off windrower engine, and inspect platform.
4. On a new machine, avoid heavy loading during initial two hours of field operation. Operate windrower at rated engine speed and set ground speed multi-function lever to at least 80% of windrowers normal ground speed setting.



### CAUTION

To avoid bodily injury, disengage platform and shut off windrower engine before starting pre-checks.



### CAUTION

Always disengage platform drive and shut off windrower engine before inspecting machine to avoid personal injury.

## Overview of the Operator's Manual

There are three operator manuals available for the operator of this machine, for more detailed information on the operation of the W235R & W260R refer to the John Deere W235R & W260R on screen or printed manuals.

To access the screen version for the W260R select the help icon  (A) on the home screen.

The SC1500 operators manual helps you to navigate the standard John Deere features that are used in conjunction with the integrated Hillco SC1500 features. Please take the time to familiarize yourself with the manuals for correct operation and safety.

The W235R and W260R controls will allow the operator to control these SC1500 function:

- Header Lift/Lower
- Header Tilt
- Cutterbar Speed
- Header Float Pressure

Automatically control:

- Solution Spray
- Output Auxiliary Power

The SC1500 monitor will allow the operator to adjust:

- Drum Speed
- Drum Speed Swap
- Header Lights
- Solution Spray - Manual
- Output Auxiliary Power - Manual
- Knockdown Barn
- Calibrations of valves



## SC1500 Control Display Overview

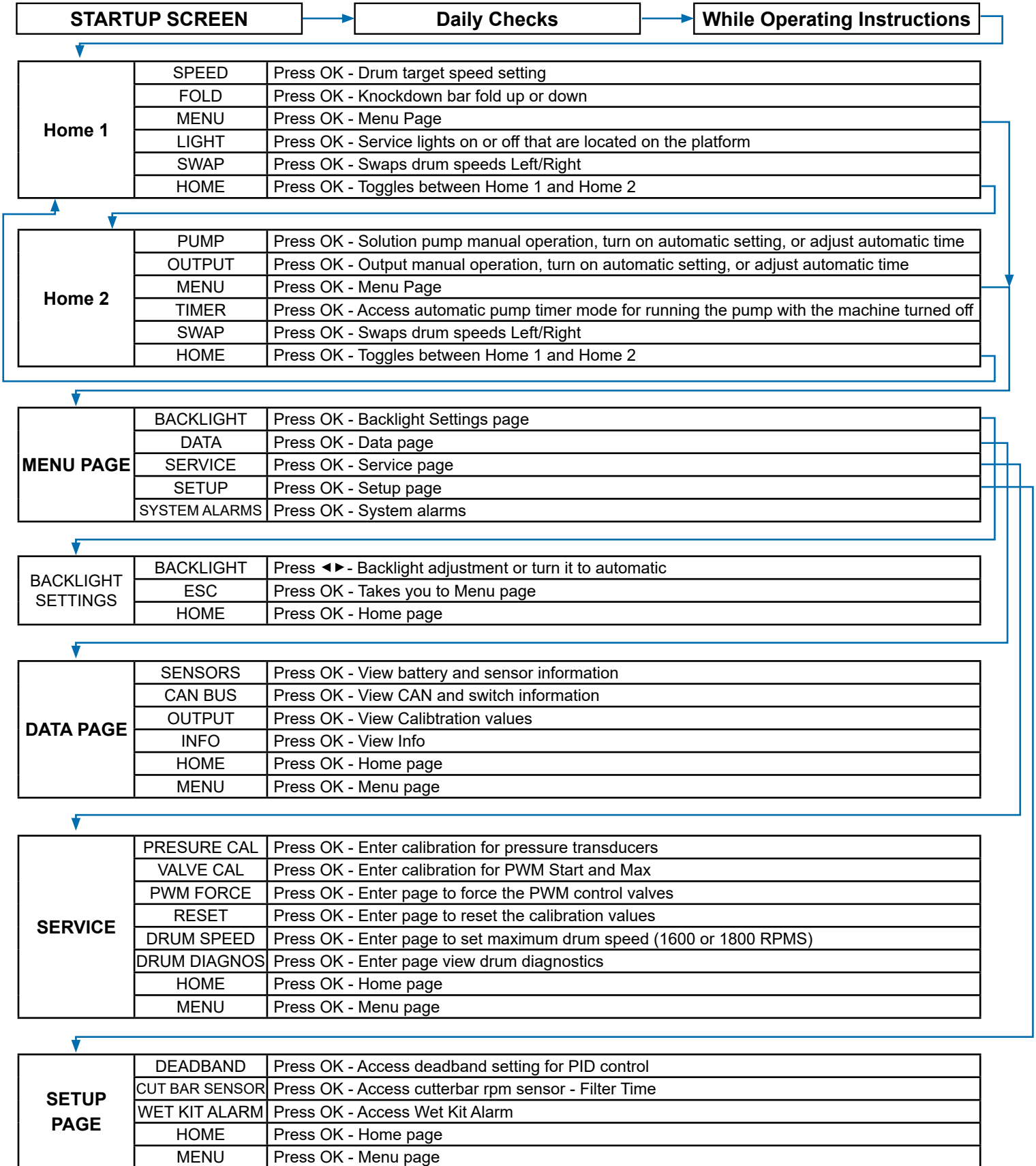

The above chart is a quick reference for you to use when navigating the system.  
 Service pages are protected by a password, that password is 18  
 Setup pages are protected by a password, that password is 22

## Operation

### GENERAL OPERATION

Control systems are added for the SC1500 system and some are integrated with John Deere functions.

### OPERATION OF HEADER SYSTEM

The same switch you use to operate the platform on a standard JD control also operates the control for the added drums and cutterbar.

The operators station has a yellow switch (A) to turn on the platform.

On the right side of the Command Center is the the drum speed encoder knob (B).

The SC1500 monitor can be positioned in multiple locations.

Multi-Function Lever - See following pages for operational controls.

### Monitor Location

The monitor can be relocated to three different positions. In the top and left location the monitor can be moved in the slotted track to the desired location. To relocate the monitor remove the two knurled clamping nuts on the back side and move the monitor to the desired spots and retighten the knurled nuts.

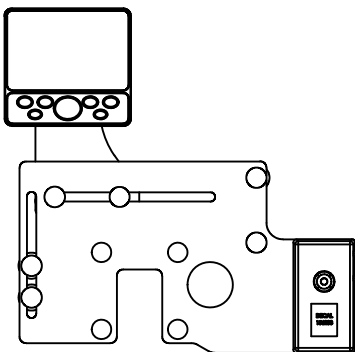

SCREEN LOCATION OPTION 1

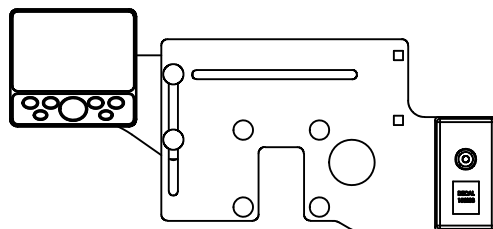

SCREEN LOCATION OPTION 2

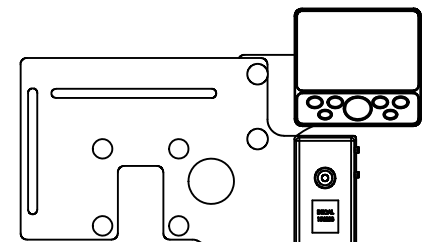

SCREEN LOCATION OPTION 3

## Multi-Function Lever Operational Controls

### Raise and Lower Platform

*NOTE: To raise and lower platform, select raise or lower position on rocker switch (A) on multi-function lever.*

Rocker switch (A) controls raising and lowering platform.

#### Manual Raise

To raise platform, press and hold switch until desired height is reached.

#### Manual Lower

- To lower platform, press and hold switch until desired height is reached.
- Low Idle: Will lower when first or second detent is pressed.
- High or Variable Idle: Will lower with first and second detent, if in high speed gear, with header off.

See following section for Automatic controls using the Header Activation Buttons.



### CAUTION

When raising platform for service or transporting, always engage platform lift lockout lever (B).



## Adjust Platform Cutterbar Angle

Set rotary cutterbar angle and gauge shoe height to Optimize cutting performance of platform, at same time using care to protect knives, guards, and platform from obstacles in field.

NOTE: It is not necessary to engage platform drive to set cutterbar angle.

Changing cutterbar angle will affect platform cutting height.

1. Sound horn, start engine, and lower platform to ground.
2. Press upper portion of switch (A) to increase cutterbar angle.
3. Press lower portion of switch (A) to decrease cutterbar angle.
4. Decal (B) on gauge (C) shows approximate number of degrees cutterbar angle is below horizontal (zero).
5. Check and adjust gauge shoe height. (See Adjust Gauge Shoe in this section.)
6. Check and adjust platform float. (See Adjust Platform Float in this section.)

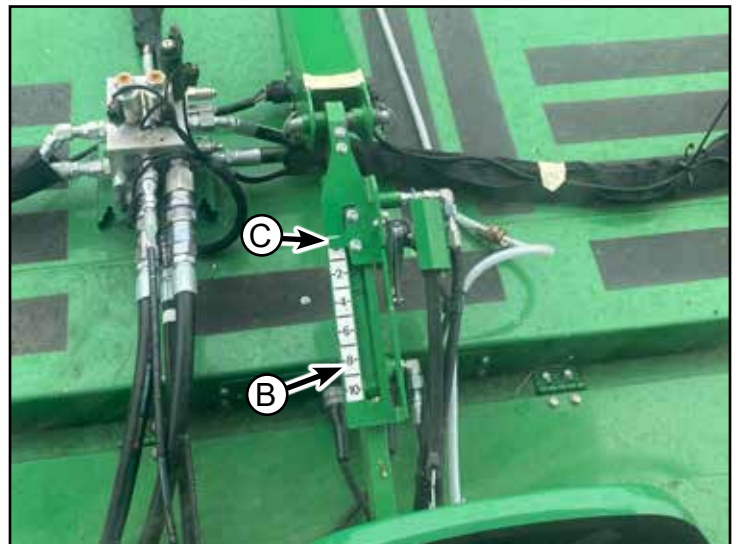

### Adjust Cutter Bar Speed (Header Set Speed)

Press the “Header/Reel Speed Switch” (A) up or down to change the cutterbar speed. On the screen you will see your target setting. (B)



### Adjust Header Float PSI

Press the “Reel Position/Float Pressure Switch” (C) up or down to change the cutterbar speed. Use the left and right buttons on the same switch to toggle between the left and right pressure setting. Use the up and down arrows to change the pressure up or down.



## Header Automatic Controls

Header Activation Buttons (A) allows the operator to activate the following by pressing one of the three buttons:

- John Deere controls
  - Header Height Resume
  - Header Tilt Resume
  - Header Speed Resume
  - Guidance Resume

- SC1500 controls
  - Solution Spray on/off
  - Output Auxiliary Power on/off

The header control system takes control and moves the header to your selected position. The header positions obtained by pressing the activation buttons can be overcome by pressing the reel raise/lower or reel fore/aft switch.

The operator can set and save the current header settings to one of the three header activation buttons by pressing and holding the activation buttons for 2 seconds.

### System Requirements

- A properly equipped header is connected
- The engine is running
- the header is engaged
- At least one of the resume preferences is enabled.

To enable the John Deere go:

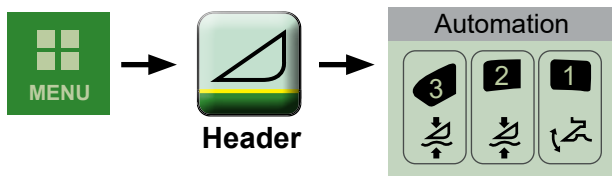

Turn the desired John Deere automation functions on/off.

The Header Activation Buttons (A) can also control the SC1500 Solution Spray (B) & Output Auxiliary Power (C). Turning on the Solution Spray engages the pump which sprays the cutterbar when you raise the header at the end of a row or corner of a field. You get to select the time 5,10,15 seconds. This is done by using either button #1 or the up button to raise the header. If you push either buttons #2 or #3 or the down button it cancels the spray. You can also integrate an electrical output for down in the same way. To turn these options on/off follow the steps on page 46 under the “Pump” and “Output” section.



## Monitor Operation

A service reminder comes on each time you start the machine. This reminder tells you to check your:

1. Quill Bearings
2. Drum Bearings
3. Water level in the spray tank.

After you check, press OK, then there is a reminder for other critical functions.

This screen comes on as a quick reminder and helps you or your operators to adjust for conditions.

The Home screen shows what functions are on /off and the speeds and pressure.

The bottom buttons allow for more options.

The following pages will show you what each icon means and will step you through how to make adjustments.

Note: There are two Home Screens. Home 1 and Home 2. Press the Home button (A) to toggle between the two. The options on the bottom change between Home 1 and 2.

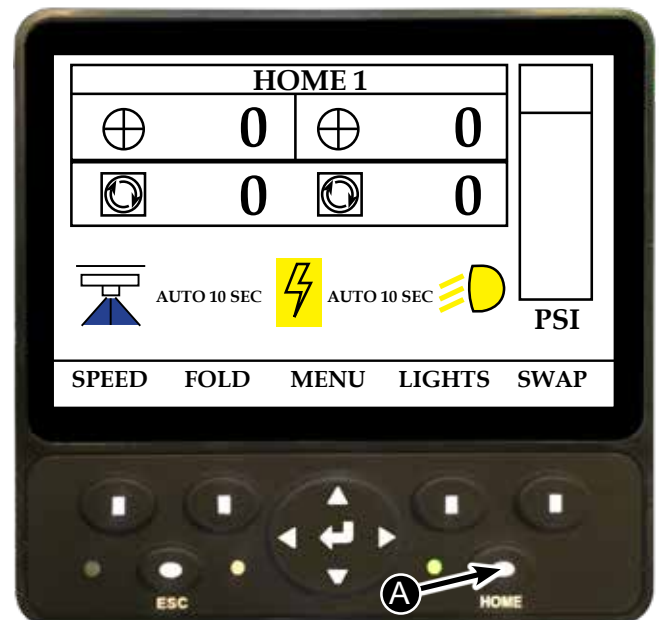

## Home Screen Icons

**Target Speed** for the left drums (A) and right drums (B) is displayed at the top of the Home 1 or Home 2 screen.

**Actual Speed** for the left drums (C) and right drums (D) is displayed below target speed on the Home 1 or Home 2 screen.

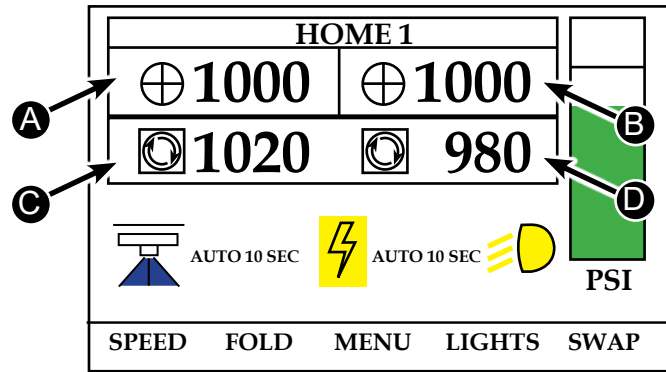

## Solution Spray

When solution sprayer (E) is on it will have a blue background

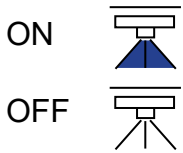

## Output Auxiliary Power

When Output Auxiliary power icon (F) is on it will have a yellow background.

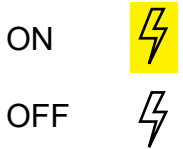

This wire's plug (H) is located inside the frame rail near the battery on the right side of the machine.

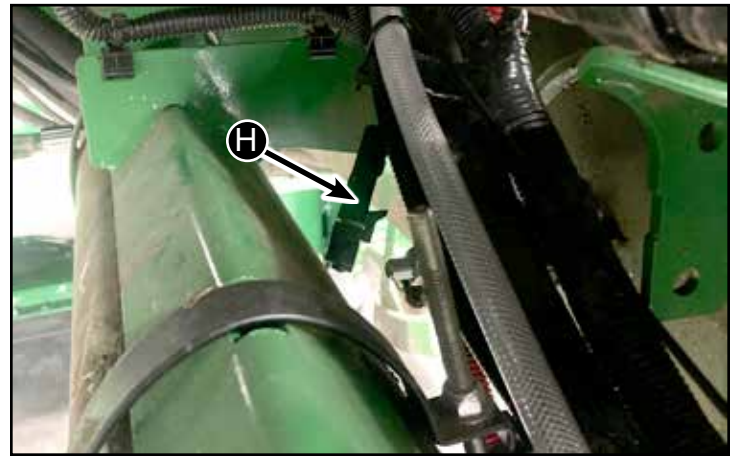
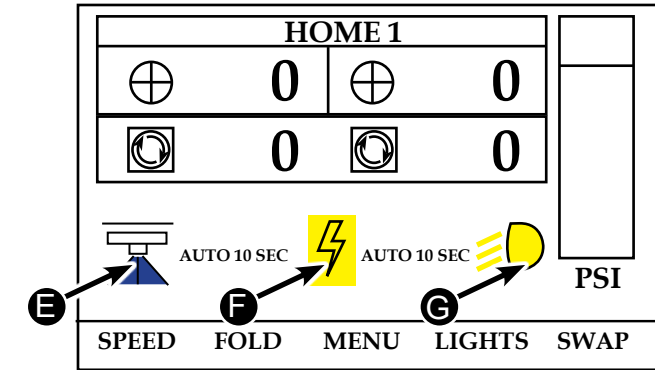

## Lights

When Lights (G) is on it will have a yellow background.

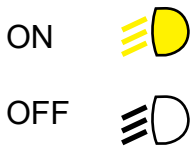

This screen shows the power meter on the right side of the screen (I) when the system it is operating. This is provided by a pressure transducer in the hydraulic system. The power meter refers to the hydraulic power for the drums, not the cutterbar.

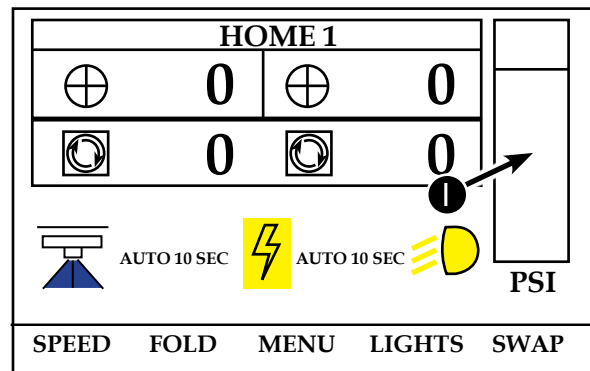

## Home 1

The "HOME 1" text appears when on Home Screen 1. Home 1 shows options for:

**Target Speed** - Allows operator to adjust drum speed target setting for each side individually.



**Fold** - Operator can fold knockdown bar in/out.

**Menu** - Additional user options such as:

- Backlight Settings
- Data
- Service
- Setup
- System Alarms

**Lights** - Cycles the lights on/off

**Swap** - Swaps the speed settings from left/right

Use the buttons  below each option to select that option. Use the  to select the menu option.

## Home 2

Press the Home button to toggle between HOME 1 and HOME 2. The "HOME 2" text appears when on Home Screen 2. Home 2 shows options for:

**Pump** - Options for Solution Pump



**Output** - Electrical output when platform is raised/lowered

**Menu** - Additional user options such as:

- Backlight Settings
- Data
- Service
- Setup
- System Alarms

**Timer** - Automatic Pump Timer settings

**Swap** - Swaps the speed settings from left/right

Use the buttons  below each option to select that option. Use the  to select the menu option.

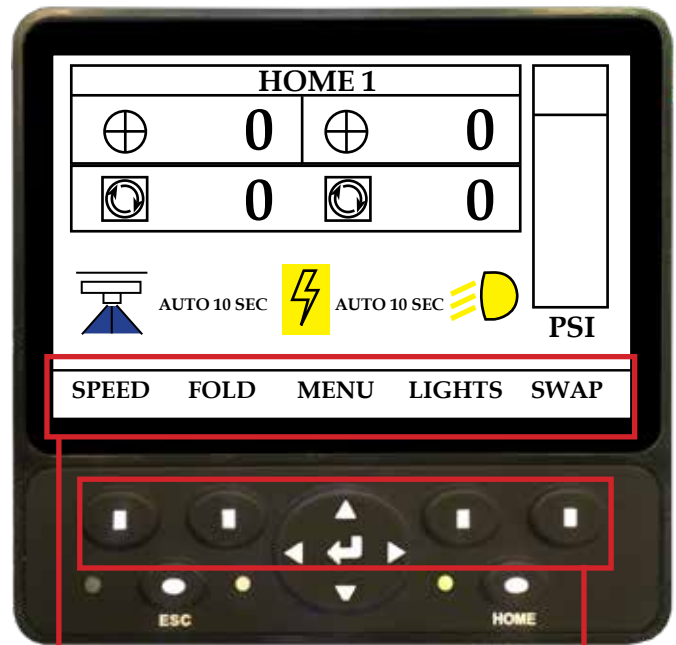

Home 1 Options

Selection Buttons

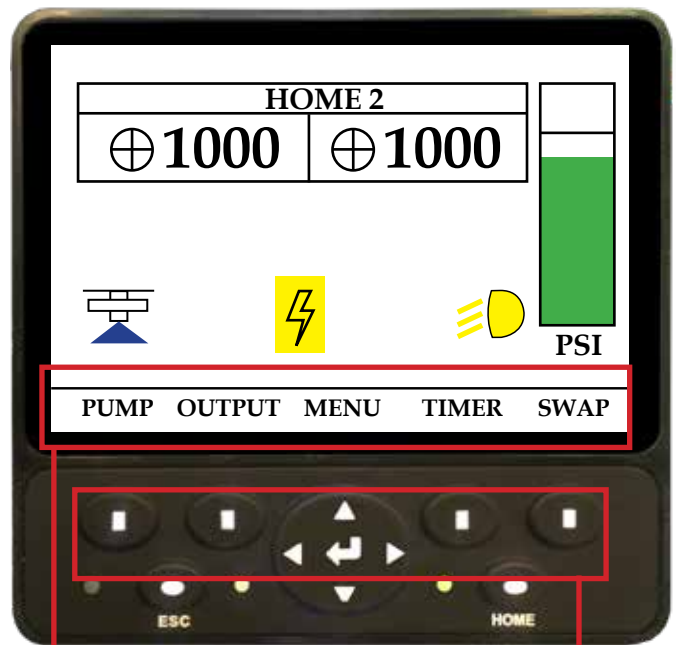

Home 2 Options

Selection Buttons

## Target Speeds of Drums - Select Speed

From Home 1 select the “Speed” button (A) in the bottom left of the screen.

Critical to the operation of the machine is the speed control of the drums. This system allows them to be individually adjusted for conditions and will allow you to "toggle" the speed when cutting back and forth.

Follow the instructions on the screen to increase or decrease your target speed.

The settings will be saved when “Settings Saved” appears in green in the middle of the screen

You can have 2 different speeds LH vs. RH After selection of speed go back to the run page while operating.

In addition to setting the drum speed on the screen you may also use the encoder knob (B) to adjust speeds while operating. Turning this knob will change the speeds in 50 RPM increments. It will move both RH and LH speeds up or down at the same time. If you have an offset in the speed # it will keep the offset and move both numbers up or down.

Rotate knob (B) slowly for best accuracy.

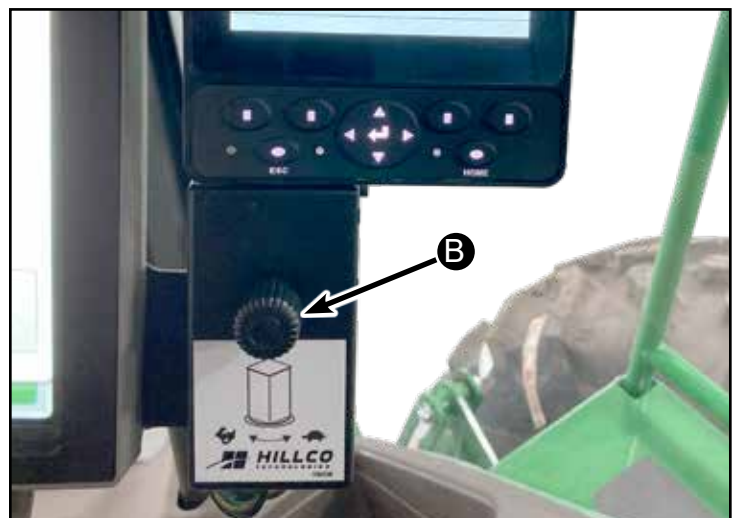

## Knockdown Bar

From Home 1 select the “FOLD” button (A) in the bottom left of the screen.



Follow the steps on the screen to fold the knockdown bar (B) in our out.

As you raise and lower the knockdown bar the psi bar on the right will go up and down. The colors range from green, to yellow to red. Green being low pressure and red being high pressure.

The pressure in PSI is also displayed.



**⚠ CAUTION**

Caution! Do not operate on roads with the knockdown bar folded out. The knockdown bar impedes the operator's vision on road ways.

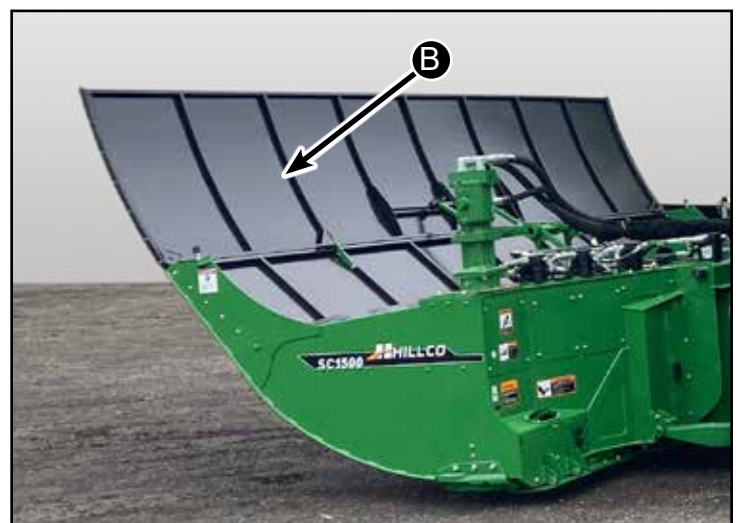

## Main Menu

The MENU page give you access to an additional number of items:

- BACKLIGHT SETTINGS
- DATA
- SERVICE
- SETUP
- SYSTEM ALARMS

OPTIONS and Service are protected by passwords. Contact Dealership or Hillco for passwords or refer to the Hillco Setup Manual

## Backlight Settings

The backlight can be changed from Automatic to a % of brightness by increments of 1-10 which is 10% to 100% brightness.

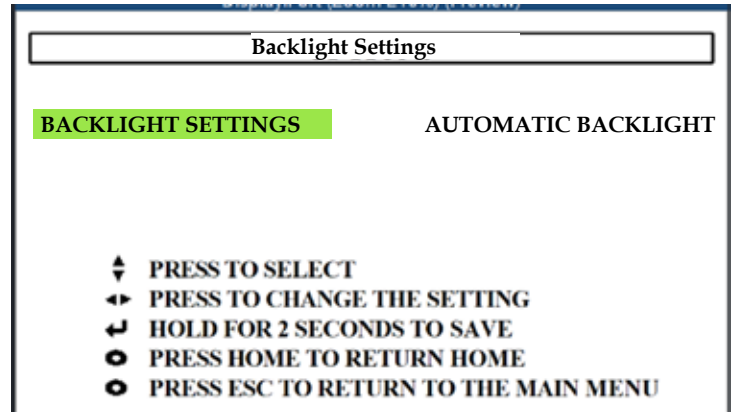
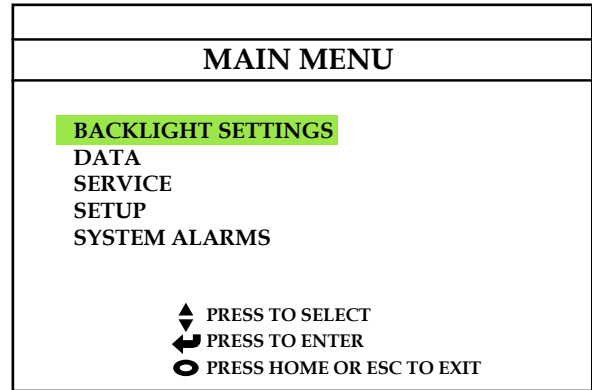

## Data Menu

In the Data menu you see information for:

SENSORS  
CAN BUS  
OUTPUT  
INFO

Sensor Information shows volts, speeds, and pressures for the SC1500 systems.

CAN signals that the SC1500 reads from the John Deere Traction Unit.

You must have engine running to read the Platform switch. All others can be done with key on engine not running.

Output shows the values for the Left and Right PWM.

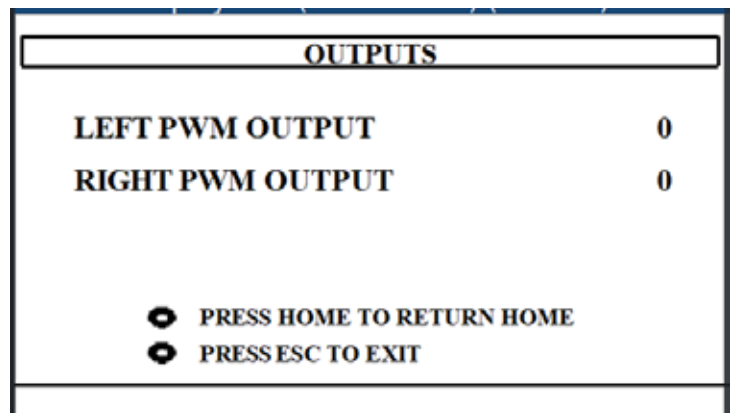
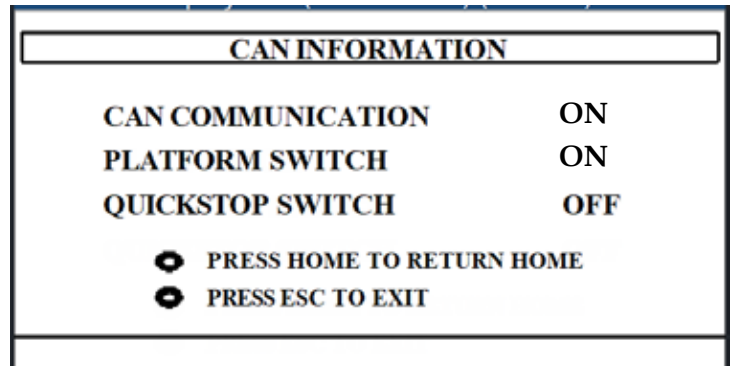
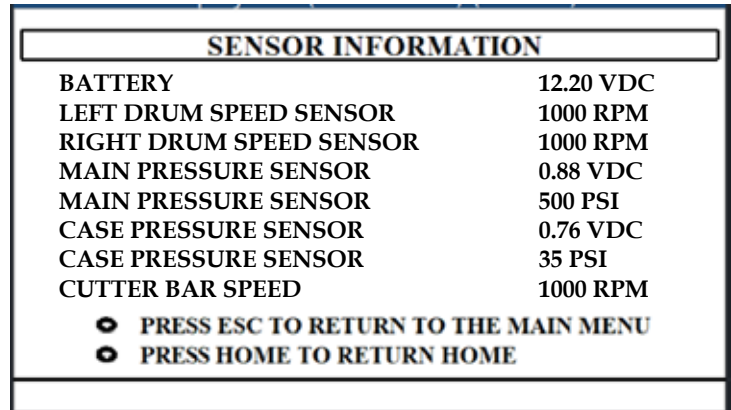
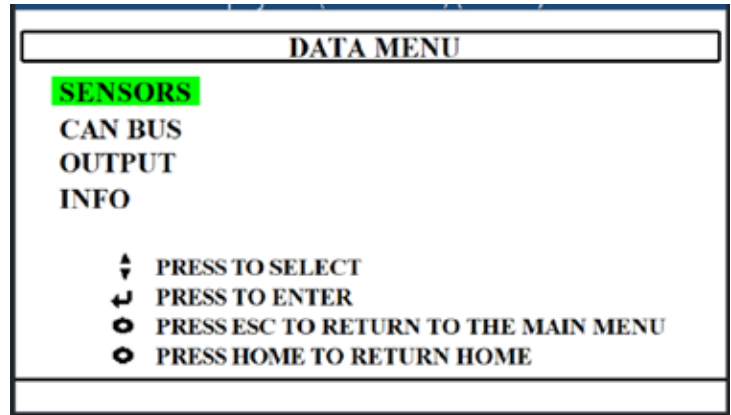

The Info screen shows the PWM calibration values for both sets of drums. It also shows display software and controller software version information.

Note: Contact Hillco for the correct version of software for the display and controller.

<b>INFO</b>	
PWM START LEFT	1600
PWM START RIGHT	1800
PWM MAX LEFT	5800
PWM MAX RIGHT	5900
DISPLAY SOFTWARE	1380981
CONTROLLER SOFTWARE	1380992
<hr/>	
<b>●</b>	<b>PRESS HOME TO RETURN HOME</b>
<b>●</b>	<b>PRESS ESC TO EXIT</b>

## Service

The Service page is password protected.

Password is 18

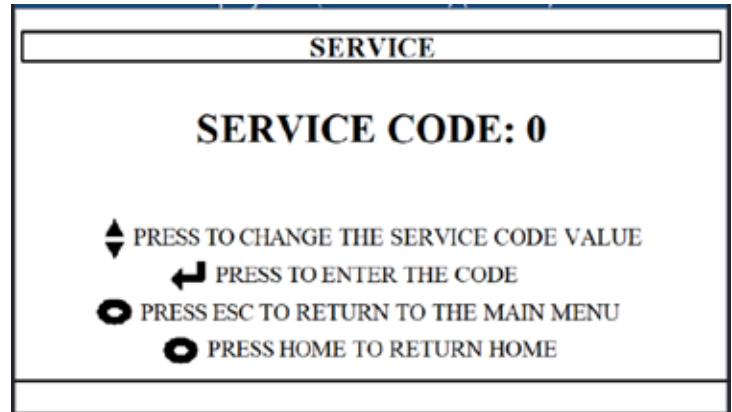

From the Service screen you can:

Pressure Sensor Calibration - calibrates the main and case drain pressors sensors. See Calibration Section

Valves: PWM Valve Calibrations - Calibrates the start and max PWM values. See Calibration Section

PWM Valve Force - PWM valve can be manually controlled. Operator must be in the seat to force the valve. Feedback % will be displayed. The closer the feedback is to 100% the better the connection through the coil. The drum speed RPM is also visible on this screen.

Reset Calibration - Resets all calibrations.

Drum Speed Range - Sets a maximum drum speed.

Drum Diagnostics - Shows information for drums such as target speed, actual speed, case pressure and main pressure sensor psi.

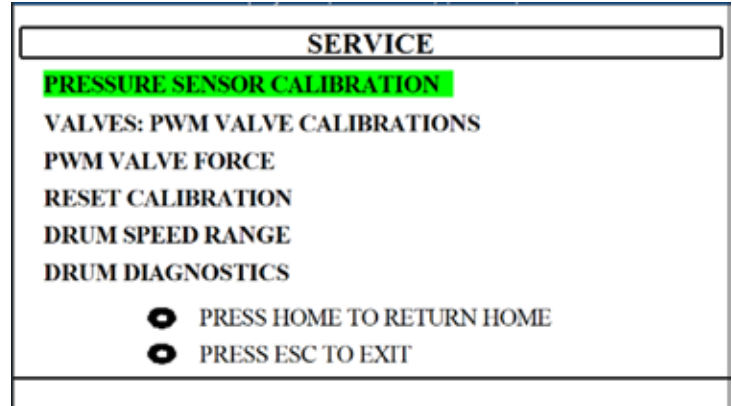

To calibrate the Main, Case and PWM Start and Max values go to the calibration section of the operator's manual for step by step instructions.

PRESSURE SENSOR CALIBRATION	
MAIN PRESSURE SENSOR	0.00 VDC
CASE PRESSURE SENSOR	0.00 VDC
<p>↵ PRESS AND HOLD FOR 2 SECONDS TO CALIBRATE</p> <p>⊙ PRESS ESC FOR SERVICE - HOME RETURNS HOME</p>	

PWM START CALIBRATION	
LH RPM 0	LH PWM START 0
RH RPM 0	RH PWM START 0
<p>SET ENGINE TO HIGH IDLE</p> <p>↵ PRESS AND HOLD UNTIL CALIBRATION IS COMPLETE</p> <p>⊙ PRESS THE BUTTON BELOW TO MAKE A SELECTION</p> <p>⊙ PRESS ESC FOR SERVICE - HOME RETURNS HOME</p>	
START	MAX

Note: If you get the below error for either the LEFT or RIGHT PWM valve, follow the steps listed. If the error persists contact Hillco.

RIGHT PWM CALIBRATION FAILURE
<ul style="list-style-type: none"> <li>◦ CHECK THAT HYDRAULIC OIL TEMP IS 120° F</li> <li>◦ CHECK PWM VALVE TORQUE IS 32 FT/LB</li> <li>◦ CHECK THAT ALL DRUMS ROTATE FREELY</li> <li>◦ REPLACE PWM VALVE IF NECESSARY</li> <li>◦ REPEAT CALIBRATION</li> </ul>
<p>⊙ PRESS ESC TO RETURN TO CALIBRATION</p> <p>⊙ PRESS HOME TO RETURN HOME</p>

PWM MAX CALIBRATION	
LH RPM 0	LH PWM MAX 0
RH RPM 0	RH PWM MAX 0
<p>SET ENGINE TO HIGH IDLE</p> <p>↵ PRESS AND HOLD UNTIL CALIBRATION IS COMPLETE</p> <p>⊙ PRESS THE BUTTON BELOW TO MAKE A SELECTION</p> <p>⊙ PRESS ESC FOR SERVICE - HOME RETURNS HOME</p>	
START	MAX

### PWM Valve Force

This is a way of testing the drums by forcing the valves to open at a specified duty cycle.

PWM VALVE FORCE		
LH RPM 0	OFF	RH RPM 0
OUTPUT 0	DUTY CYCLE 0	OUTPUT 0
FEEDBACK 0 %		FEEDBACK 0 %
<p>▲ PRESS TO CHANGE THE DUTY CYCLE</p> <p>↵ PRESS TO FORCE THE VALVES ON/OFF</p> <p>⊙ PRESS ESC FOR SERVICE - HOME RETURNS HOME</p>		

Reset Calibration - Resets all calibrations.

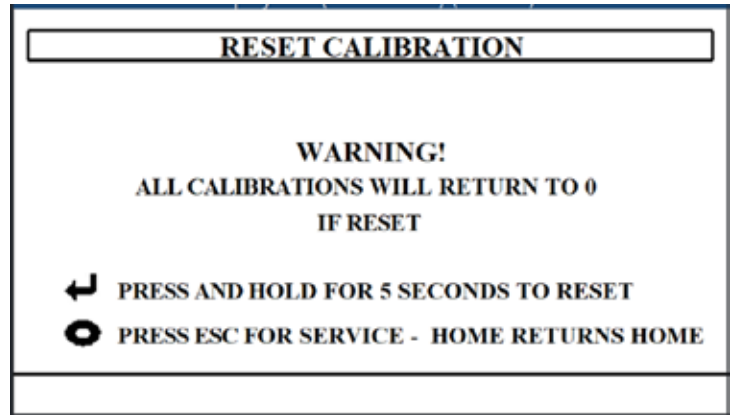

Operator can select either 1600 rpms or 1800 rpms for a max drum speed.

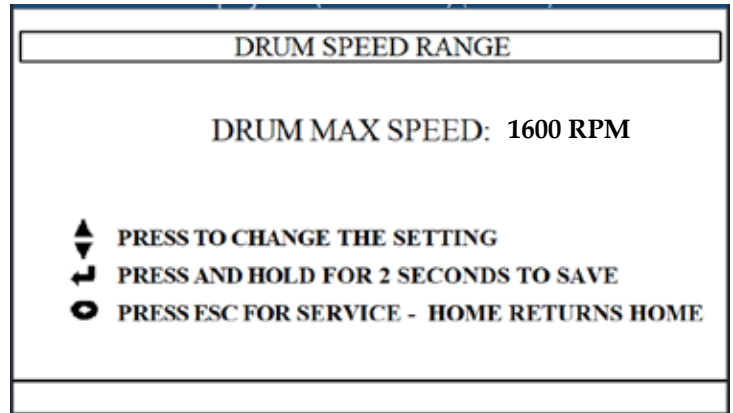

### Drum Diagnostics

Drums can be run at a set speed without the cutterbar operating.

Shows information for drums such as target speed, actual speed, case pressure and main pressure sensor psi.

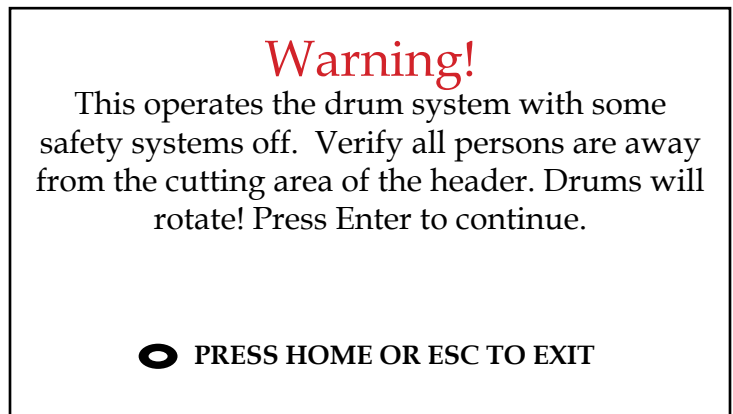

To engage drums press the button below "Drums On" (A).

When the drums engage the "Drums On" text changes to "Drums Off".

To disengage drums select the "Drums Off" button.

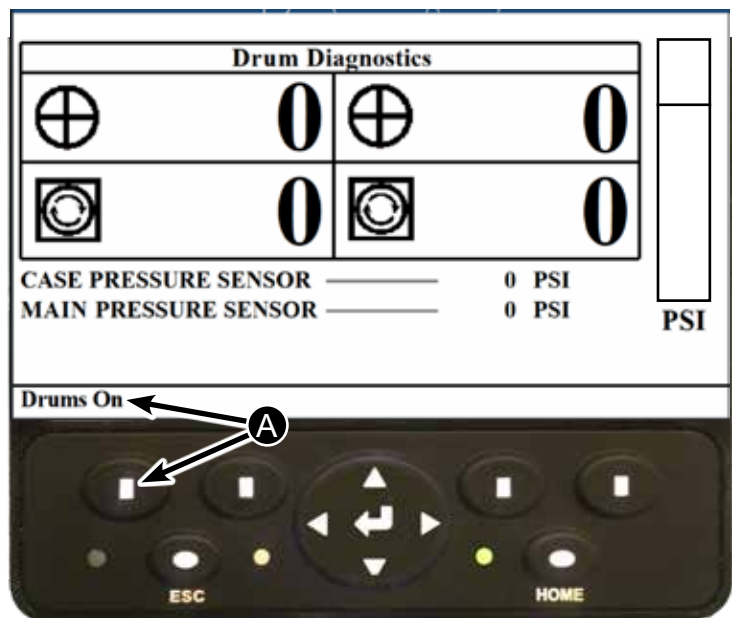

## Setup Screen

Password for setup screen is 22

## Limp Mode

If Limp Mode is ON and a speed sensor stops responding the controller will match the amperage from the working side to the non working side. If both speed sensors quit working it defaults amperage to an estimated 1200 rpm. If Limp Mode is OFF and a speed controller stops working the controller will send it maximum amperage.

This sets the sensitivity of the drum speed response. The higher the value the more sensitive the response.

This setting adjusts the speed sensor output to the John Deere System. The higher the value the more stable but has more lag time

Default: 9

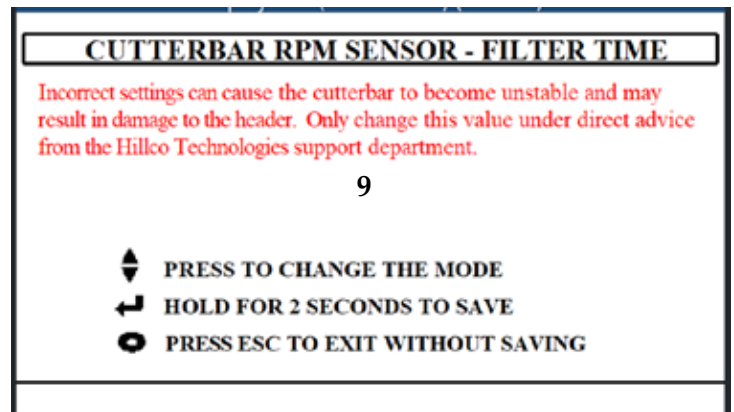
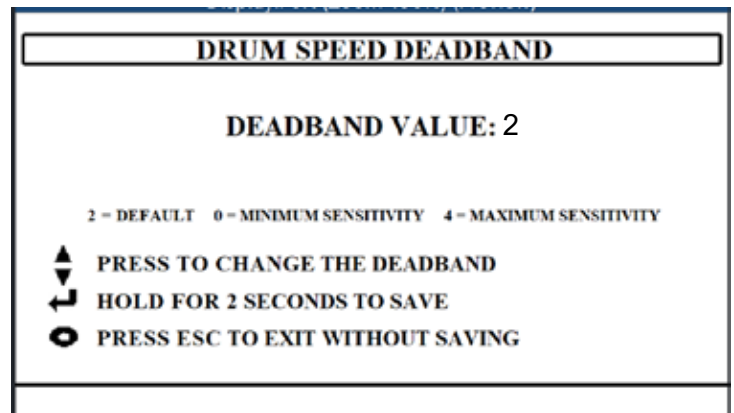
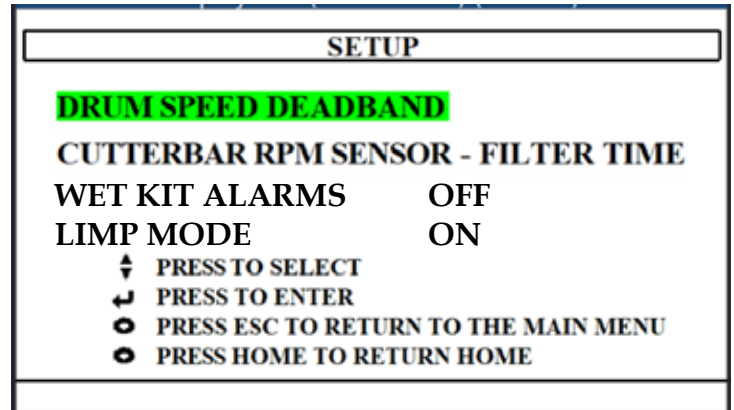
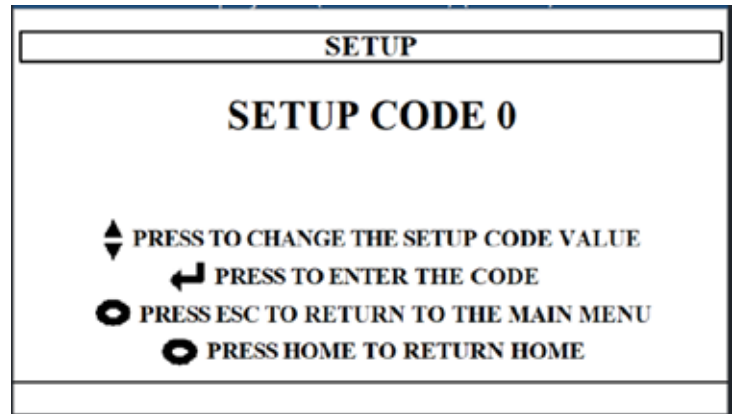

## Notifications & System Alarms

To the right is (A) an example of how messages might appear to the operator.

System alarms appear in red.

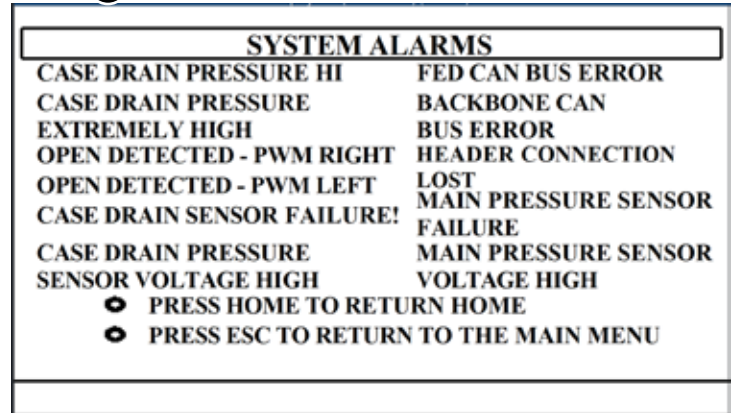
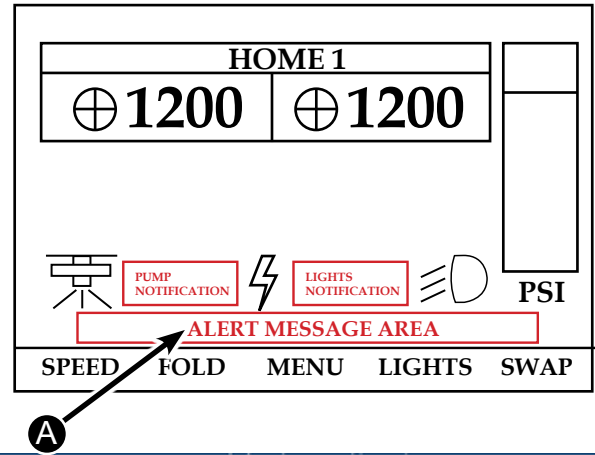

The system alarm (B) shows up in the lower left corner. When an alarm occurs the alarm page pops up and notifies the operator of the problem. The operator can return to the home screen but the icon (B) appears on the home screen until the problem is resolved.

There are alarms for the following:

### Drum Speed

- Left Drum Speed Low
- Left Drum Speed High
- Left Drum Speed Low
- Left Drum Speed High

### Calibration Incomplete

### Wet Kit

- Tank Empty/Strainer Plugged
- Broken Nozzle
- Plugged Nozzle

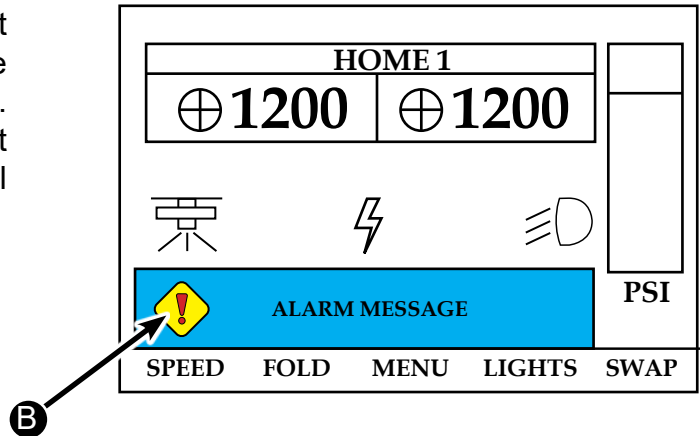

## PUMP

When you enter the pump mode you will see this screen and be able to select:

**Spray when Platform Raised:** ON, 5, 10 or 15 seconds

Manual spray      ON   OFF

**Spray when Platform Lowered** ON, continuous

Solution mix:

mix with 50 gallons of clean water

6 oz. of Wetter Sticker

12 oz. Rubbing alcohol

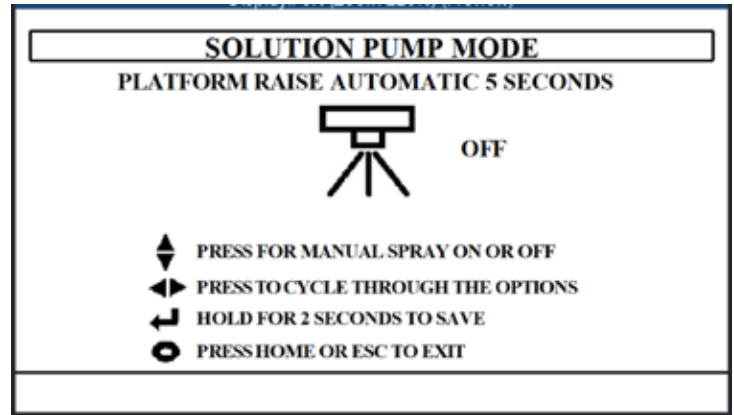

## OUTPUT

Output mode is for a trigger wire is integrated into the harness that runs back to the solution pump. That trigger wire is available to operate a relay to provide power for different customer functions. See previous page for wire location. When you select the output mode you will be able to select:

**Output when Platform Raised** ON, 5, 10, 15 seconds

**Manual Output:** ON OFF

**Output when Platform Lowered:** ON

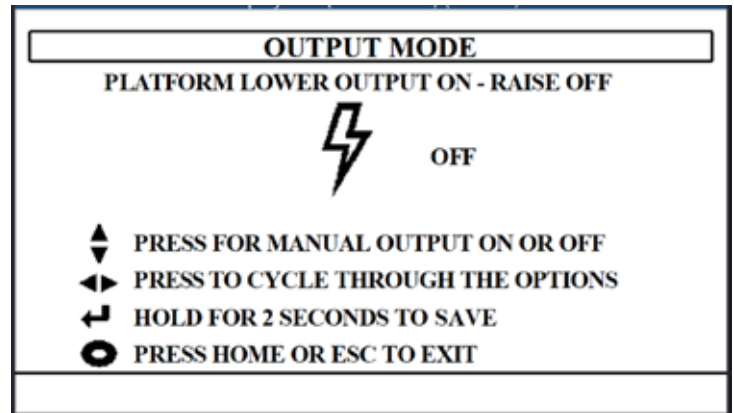

## AUTOMATIC PUMP TIMER

This option allows the operator to program the controller to operate the pump system to clean the cutterbar when it is not being used.

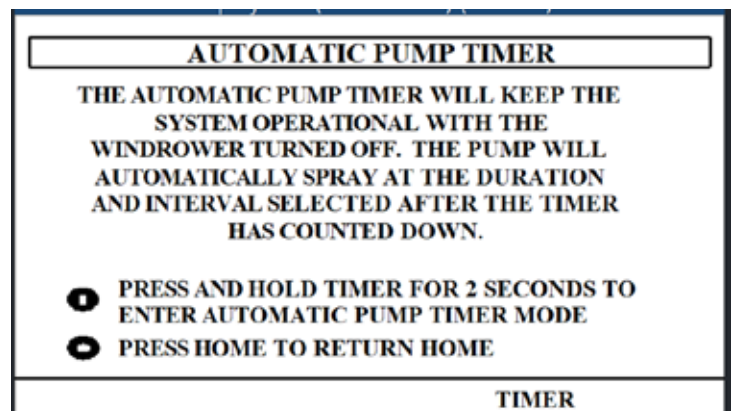

# Crop Conditions Recommendations

Note \* If you are uncertain about Cutterbar RPM's and Drum RPM's start out at a high setting and work you way down to a lower RPM if you need to.

Crop	Crop Conditions	Cutter Bar Speed	Drum Speed	Shoe Gauge Position	Approximate Ground Speed	Knockdown Bar	Misc. Notes
Tall Fescue	Heavy Down	3000 RPM	1600 RPM	1-2	8-10	Yes	Direction of crop lean will determine speed
Tall Fescue	Light	2600-3000 RPM or less	1000-1600 RPM	2	12-14	Yes	Standing tall fescue cuts very easy
Fine Fescue	Heavy Down	3000 RPM	1600 RPM	1-2	8-10	No	May need to use all 10.5's to make windrow look uniform
Fine Fescue	Light	2600-3000 RPM or less	1100-1600 RPM	1-2	12-14	Maybe	Use slower drum speed for better windrow
Annual Ryegrass	Heavy Down	3000 RPM	1600 RPM	1	8-10	No	Cut height is low will need to change knives more often
Annual Ryegrass	Light	2600-3000 RPM or less	1100-1600 RPM	2	12-14	No	Same note as above
Perennial Ryegrass	Heavy Down	3000 RPM	1600 RPM	1	10-11	No	Cut height is low will need to change knives more often
Perennial Ryegrass	Light	2600-3000 RPM or less	1200-1600 RPM	1	10-14	No	Dry brown thin cuts hard
Bluegrass	Heavy	3000 RPM	1600	2	8-12	Maybe	Wet cuts hard, Slower forward speed
Bent Grass	Heavy	3000 RPM	1600	1	8-12	No	Can be tough to cut depending on the year
Meadow foam	Average	800-1200	700-1200	1	10-15	No	Very light thin crop do not need much to form windrow
Clover	Heavy	800-3000	1000-1600	1	10-14	No	Lower drum speed or may need to lower cutterbar speed
Sugar Beets	Average	3000 RPM	1600	2-3	8-10	Yes	Very tall tangled crop may need to change accelerator configuration
Turnips	Average	1800-3000	1600	2	10-14	Yes	Easy cutting
Radish	Average	1600-3000	1600	2	10-15	Yes	Easy cutting

## Notes:

- a. Knives - Use 11° knives unless additional lift is needed.
- b. Accelerators - Start with no accelerators. If crop bunches add accelerator to 3 & 7.

## Gauge Shoe Position

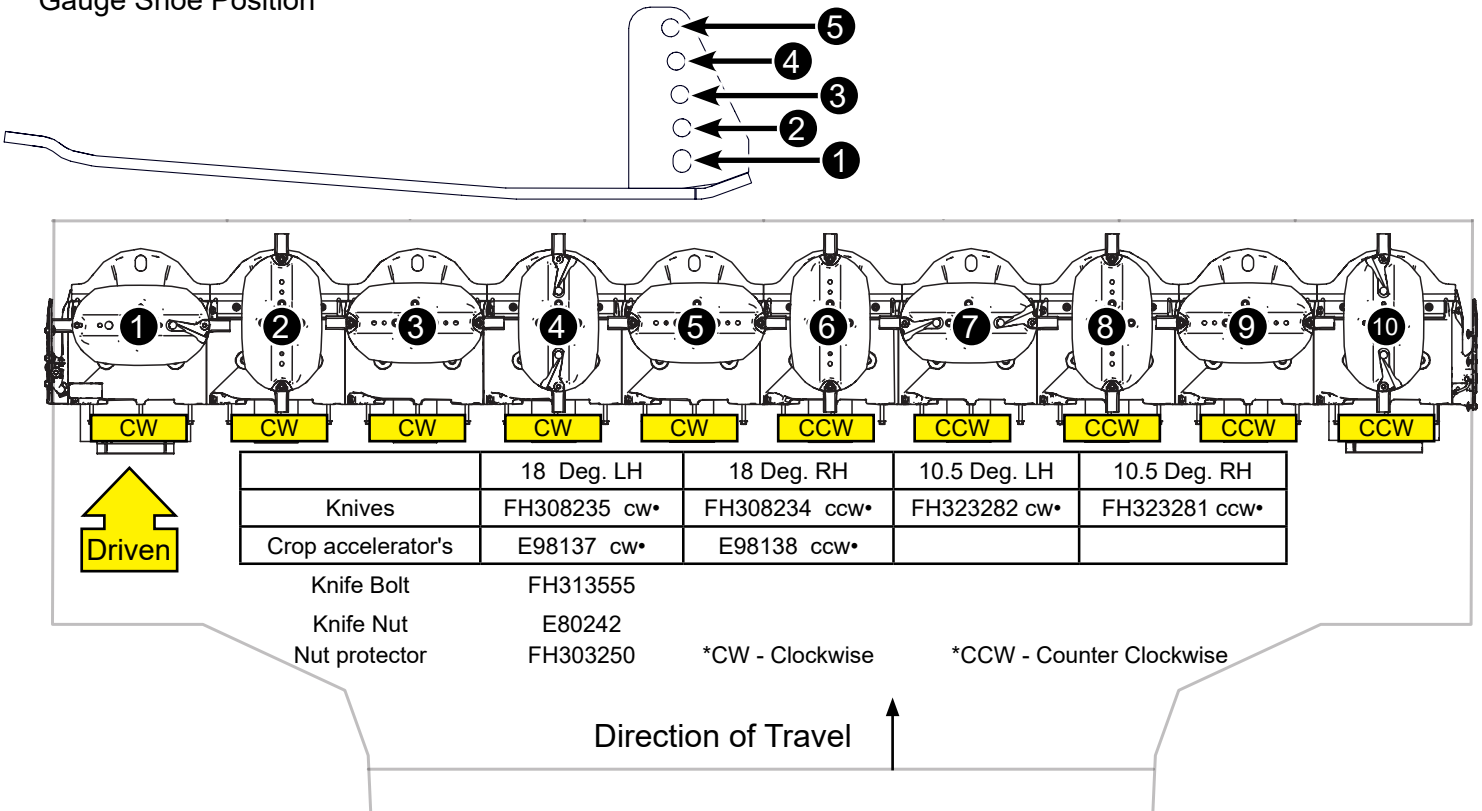

## Troubleshooting

Symptom	Problem	Solution
<b>Excessive noise and vibration</b>	Driveline U-joint failure.	Replace U-joint.
	Bent drum shaft	Replace shaft.
	Damaged drum.	Replace Drum
	Missing knives or cutterbar parts	Replace missing parts
<b>Windrow Quality</b>	Windrow too wide	Increase travel speed or increase drum speed or install crop accelerators
	Windrow too narrow.	Slow down travel speed or slow down drum speed
	Drum not turning	Unplug drum or check shaft coupler
	Windrow bunching	To low drum speed or knives broken or dull or forming drums are not turning, open rear vent holes
	Excessive Seed loss	Increase ground speed, lower cutterbar speed, lower drum speed, install 10.5 deg. Knives, remove crop accelerators
	Windrow tee-pee in center	Reduce drum speed.
<b>Cutterbar plugging</b>	Wet crop or ground conditions	Reduce platform angle or adjust cutting height, lighten up header ground pressure
	Platform speed too low.	Increase cutterbar or drum speed.
<b>Cut is not clean</b>	Knives are dull	Replace knives
	Knives installed incorrectly	Make sure LH & RH knives are in correct locations
	Platform not correct height	Adjust skid shoes for lower cut
	Down or lodged crop	Tilt header so cut is closer to ground
	Possible shear hub sheared	Replace shear hub if sheared
	Cut not equal left to right	Adjust header pressure left side and right side or equal
	Cutterbar speed to low	Increase cutterbar speed
Uncut strips of crop	Dull knife or knife missing or installed incorrectly, not enough ground pressure	

## Theory of Operation

The intent of the SC1500 to cut and windrow seed crops such as ryegrass, fescue, and bluegrass while minimize seed loss. The SC1500 is not compatible with haying operations. The preferred cross section of the windrow is rectangular and uniform with the crop pointing away from the direction of the cut. This cross section dries quicker and feeds into the combine easier. The SC1500 uses the converging drums to build an airflow across the back wall. This airflow creates a high pressure pocket at the end sheet. This air pocket pushes the crop towards the windrow. In addition, the airflow builds an air curtain between converging drums and the crop flow. This air curtain reduces the mechanical action of the drums which in turn minimize seed loss.

Managing this airflow is critical to optimizing the SC1500 performance. The cutterbar knives lift the crop and impel it towards the windrow. Adjusting the cutterbar speed affects the crop lift. If the cutterbar speed is too slow, then the crop will not be cleanly cut. If the cutterbar speed is too high, the converging crop flow is not smooth and tends to tumble and twist. The converging drums maintain the crop flow across the cutterbar. The converging drum speed must be high enough to maintain the crop flow, but not so fast to damage the crop.

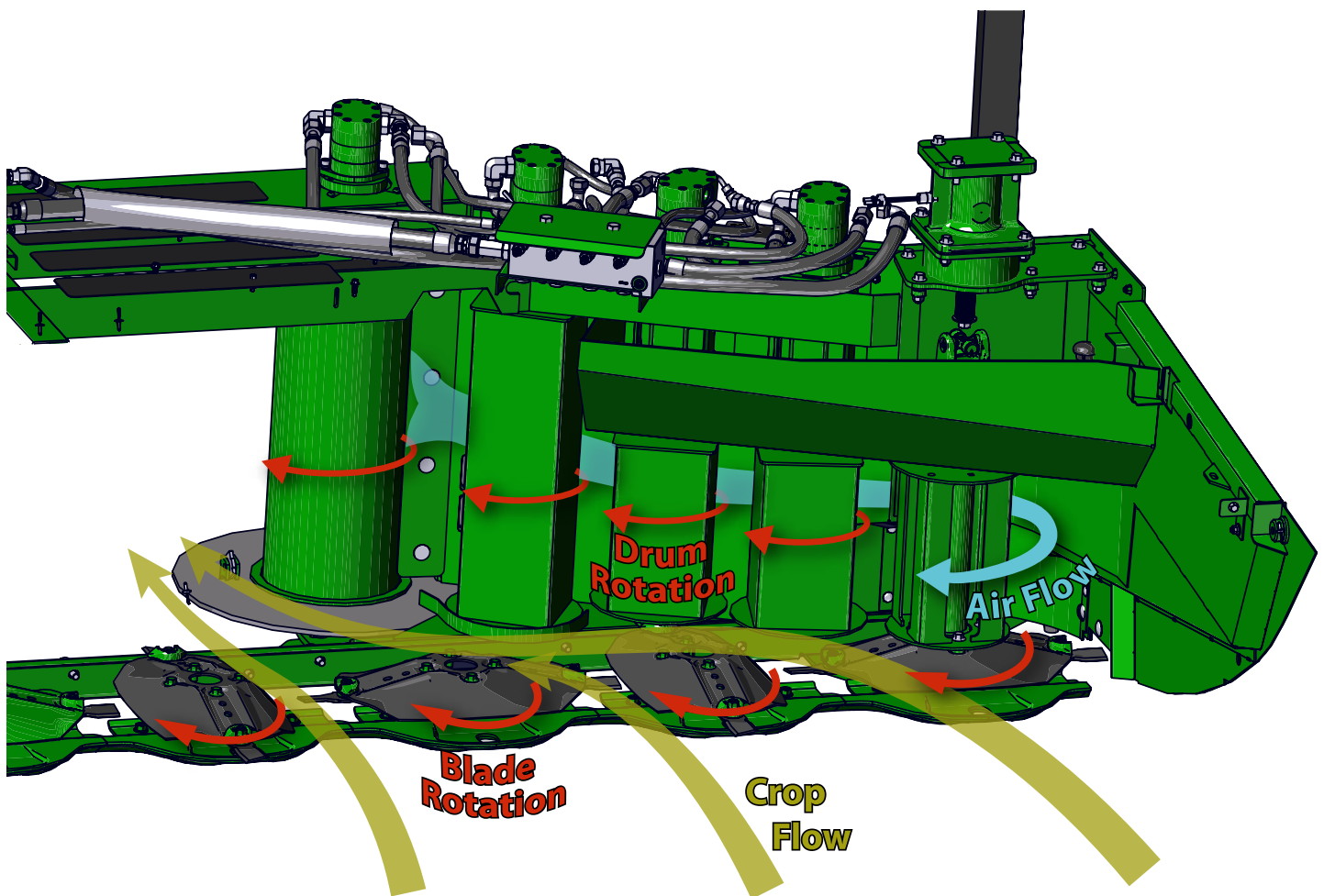

View of platform to show rotation of blades and drums and the air flow pattern. Note: parts of the header are hidden to illustrate rotation directions and air flow.

## **Platform**

The specialty crop header is equipped with three square drums (on each side) and a smooth forming drum (on each side).

To power these devices an additional pump and controls have been added to the traction unit. To control that hydraulic flow is a manifold that is mounted in the center of the platform. Control from the microprocessor and screen determine how the valves function. The flow of oil comes from the added pump and is available to power each side of the platform, and the knockdown bar up and down. There is a feedback load sense line that tells the pump what to put out.

The flow of oil goes to the outside motor first (#2) and then to the #3 and then to the #4 and then to #5. From #5 we return oil to the manifold and back to the filter and hydraulic reservoir.

There are 4 motors on each side. The first 2 motors, #2 and #3, are the same displacement. #4 is slightly larger and #5 is the largest. This provides the speed change of the drums. Outside drums are the fastest, the 3rd drum (tall drum) with a little larger displacement rotates slower yet, the 4th motor is on top of forming drum and it rotates slower to form the windrow. Control of speed is from center manifold. Program and controls are added to the W260R. Operator can independently set the drum speed for each drum group on the platform.

There are additional manifolds on each side of the platform. They are a mirror image of each other. Each manifold has 4 relief valves to protect each motor, 4 one way checks to protect each motor when you turn off the platform and allow them to slow down (via the 1 way check) and a large one way check to trap oil in the circuit so during coast down there is no cavitation.

The center manifold provides an electronic splitter, system relief valve, valve to operate the knockdown bar. The flow control valves are operated by the microprocessor on the traction unit. Drum speed is read on #3 & #8 motor and a target speed is set by the operator in the cab. In addition there are 2 electrical sending units, one for system pressure to run the power meter seen by the operator on the screen, and one for case drain.

## **Traction unit**

The JOHN DEERE W235, W260 or W260R traction unit has been converted to be able to add the additional hydraulic capacity and control of that oil.

A pump has been added as well as lines to get the oil to the platform and from the platform. There are 4 hydraulic lines that plug into the platform such as Pressure, Return, Load Sense and Case drain.

To control the system there is a screen mounted in the cab and also a microprocessor on the platform that takes commands of the screen to carry out the function of the system. There are two electrical harnesses that plug into the platform from the traction unit. One harness is for the controls for the platform and the other is for the wet kit.

## **Control System Overview:**

The SC1500 system is controlled by a Danfoss MC38-10 controller and DM430E display screen. They communicate via the CAN Bus in the SC1500 harness which is connected into the John Deere CAN system. The display has four buttons located on the bottom of the face of the display that are used to make inputs or changes to the system. The display is an operational aide and diagnostic tool. Target drum speed can be changed by rotating the Hillco knob by the screen or by adjusting it in the display. The controller and display screen are connected through the SC1500 wiring harness to the power strip.

## **Added sensor inputs for the SC1500 Conversion:**

Speed Sensor Left Sensor that monitors the drum speed of number 3 drum on the left side, sensor located in the motor.

Speed Sensor Right Sensor that monitors the drum speed of number 8 drum on the right side, sensor located in the motor.

Pressure Sensor Main Sensor that monitors the main working system pressure, located on the main hydraulic valve block on the platform.

Pressure Sensor Case Drain Sensor that monitors the case drain system pressure, located on the main hydraulic valve block on the platform.

John Deere CAN Bus Switch Data used:

- Quick Stop Switch Switch that stops the platform functions when pressed, located on the hydro handle.
- Platform Engage Switch Switch that engages the platform, located on the armrest.
- Platform Raise Switch that raises the platform, located on the multifunction control handle.
- Platform Lower Switch that lowers the platform, located on the multifunction control handle.

**SC1500 Drum Control:**

The platform has eight total converging drums: four on the left and four on the right. The left and right drum speeds can be changed independently. The motors are plumbed in two series of four: one series on the left and one series on the right. When the speed (RPM) is changed on the display screen it affects all drums on that side. The speed (RPM) is read off of drum numbers 2 and 7. Inner drums (Tall Drum & Forming Drum) spin proportionately slower than the outer drums because of larger displacement motors.

The operator will press the platform engage switch forward on the armrest which sends a CAN message that the MC38-10 controller will see as an ON. The MC38-10 controller will send out PWM signal to each control valve independently. This signal will vary depending on the target speeds and actual speeds. The DP430E display is used to interface the control system. It allows the operator to adjust the target drum speed, fold and unfold the canopy, spray the water pump, turn on the service lights, set the automatic pump timer, view diagnostic information, and calibrate the system.

The target drum RPM set in the DM430E display can be changed during operation between 500-1600 RPM. Left and right drum target speeds can be set independent of each other. When the target speed is adjusted on the display the setting is saved to memory at that time. When the speed is adjusted with the encoder the target speed is saved after five minutes. Speed signals are sent to the controller from drum motors 3 and 8.

**Hydraulic Pump:**

A closed-center load sense pressure compensated axial piston pump has been installed on the auxiliary engine drive. Oil is supplied from the standard John Deere hydraulic oil reservoir. The oil is filtered in an added filter before returning back to the John Deere system. This single pump supplies all the oil used for the SC1500 System. The standby pressure is 300 PSI and maximum pump pressure is 2030 PSI.

**Main Hydraulic Manifold:**

The main hydraulic manifold is comprised of two proportional control valves, one canopy valve, one system relief valve, one main system pressure sensor, one case drain pressure sensor, and two load sense check valves. The proportional valves control the left or the right converging drums. These valves use PWM signal that is generated from the MC38-10. The knockdown bar valve is a two function cartridge valve with two coils on the stem. It is operated with 12 VDC, one coil will retract the cylinder and the other coil will extend the cylinder, neutral is closed. Knockdown bar speed is regulated by orifices in the manifold. Main system relief is set at 3000 PSI. The system pressure sensor is a John Deere RE204264 operating off 5.0 VDC. The case drain pressure sensor is a John Deere AXE16689 operating off 5.0 VDC. Both pressure sensors have sensor signal wires that return to the MC38-10 controller.

**Hydraulic Motors:**

There are eight total hydraulic motors on the platform: four left and four right. The left side motors are plumbed in series starting with the outer motor. The right side motors are plumbed in their own series starting with the outer motor. These motors are either controled with the left or the right PWM proportional control valve depending on which side of the platform they are located. Regulated pressure oil leaves the center manifold to the left and to the right motors outer motors. The outer two motors on each side are 21 cc. The third motor in is 26 cc. The inside motor is 32 cc. These motors are protected by their own relief valves located in an aluminum block on the platform one on the left and one on the right side. These relief valves are set at 3000 PSI. Case drain oil is routed into these outer manifolds and then combined into the center manifold and then back to the machine. Return oil is routed to the center main manifold and then back to the machine. Speed signals are sent to the controller from drum motors 3 and 8.

**Knockdown Bar Cylinder:**

A hydraulic cylinder located on the platform raises or lowers the knockdown bar canopy. Its dimensions are 1.5” bore, 1” rod, and 6” stroke.

Load holding valves .....Normally closed valve, locks oil to cylinder to hold. Unlocks to allow oil to return to manifold by cross drilled passage.

**Hydraulic Valves:**

- Valve: .....Use or Control:
- Proportional Left .....Normally closed valve that meters oil the left motors PWM
- Proportional Right .....Normally closed valve that meters oil the right motors PWM
- Knockdown Bar .....Normally closed valve that extends or retracts the knockdown bar cylinder
- System Relief ..... Adjustable relief valve set at 3000 PSI Adjustable Spring

**Calibration Information:**

Calibration is performed at John Deere Dealerships after the SC1500 System controls are installed. The calibration and service screens are located under MENU, SERVICE. The Calibration Incomplete message will be displayed until the calibration procedure is completed in the Service Pages. The Pressure calibration will zero the two pressure transducers on the center manifold. The PWM Start and PWM Max calibrations must both be completed without cycling the key to get the Calibration Complete message to display. When calibration is complete the SC1500 System will be fully functional and turn on with the platform engage switch. Once the calibration has been completed a technician can perform the calibration(s) if necessary at a later date.

**Service Information:**

The DM430E display can force the left and right control valves for a service technician. The calibration and service screens are located under MENU, SERVICE. One Service Page 2 there is an option for FORCE. Here the technician can turn on the control valve and then adjust the duty cycle to spool the valves open or closed. Operator must be in the seat to force the valve. Feedback % will be displayed. The closer the feedback is to 100% the better the connection through the coil. The drum speed RPM is also visible on this screen.

**Logic Modules:** These are small programs within the overall control program in the micro controller. This is more in depth view of what logic is behind the SC1500 operation.

**Sensor Failure:** The main system pressure sensor and case drain pressure sensor signal voltage are monitored by the MC38-10 controller. If the feedback signal goes below 0.2 VDC or the signal goes above 4.9 VDC a "SENSOR FAILURE" CAN message will be sent to the DM430E to be displayed on the screen.

**EEPROM:** This area houses the information that is programmed in when the software payload is downloaded to the controller. The data contained is: Model Year, Serial Number, Control Valve T1, Control Valve P, Control Valve I, Control Valve D, Control Valve Max, Control Valve Min, Deadband Warning Speed, Controller Version M1-M2.

**Memory:** The memory area has settings that are set or adjusted by the operator are saved here. Pump timer information, Speed display, Speed setting, LED settings, Speed Deadband, Calibration Complete.

**v:** The MC38-10 controller will receive a CAN message from the DM430E display to raise or lower the canopy knockdown bar. The MC38-10 is also looking for the Deere CAN message for operator presence. It takes both signals to perform the raise or lower output function.

**PWM Calibration:**

This calibration is broken into two parts: Start Calibration and Max Calibration. To perform the start calibration the system is looking for a CAN message from the DM430E display button press calibrate PWM start and the Deere CAN message operator's presence is on. The control system will output a PWM signal to the left and right control valves. The system will slowly increase the PWM signal until the RPM on the drum is greater than 700. If the RPM gets above 700 it will decrease the PWM signal. When the system is satisfied that the RPM is between 600 and 700 RPM it will save the setting. When the left and right sides are satisfied the calibration will be completed.

Max calibration the system is looking for a CAN message from the DM430E display button press calibrate PWM max and the Deere CAN message for operator's presence is on. The control system will output a PWM signal to the left and right control valves. The system will slowly increase the PWM signal until the RPM on the drum is greater than 1800. If the RPM gets above 1900 it will decrease the PWM signal. When the system is satisfied that the RPM is between 1800 and 1900 RPM it will save the setting. When the left and right sides are satisfied the calibration will be completed.

**Valve Driver:** The valve driver portion of the control system controls the left and the right valves independently. They are a mirror image of each other. The valve driver is driven by a function called a PID Controller. This control function will have a predetermined setpoint (drum RPM) and will monitor the feedback (drum RPM) while outputting a signal that is converted to PWM signal to the control valve. It will regulate the PWM signal to keep the feedback as close as possible to the setpoint. The response of the PWM signal can be modified through the P Gain, I Gain, and D Gain. These values are preset during the download of the payload into the MC38-10 controller. The PID controller function cannot output any value without the platform engage switch on or if the operator's presence switch is not on.

**Solution Pump:** The solution pump can be operated in manual mode, automatic mode, or timer mode. When in manual mode a button press on the DM430E will tell the MC38-10 to output power to the pump to spray, this is a latching command that will stay on until another button press. Platform raise automatic mode will spray solution if the display is in automatic mode, platform engage switch is on, and the platform raise button is pressed for 700 milliseconds. The pump will run for 5 seconds, 10 seconds, or 15 seconds depending on which time option the customer has selected. Platform lower automatic mode will spray solution continuously after the lower button is held for 200 milliseconds. It will spray continuously until the platform raise button is pressed for 300 milliseconds. The final mode is the timer mode. All the timer mode logic is based in the DM430E display. The operator will set a countdown timer and what interval the pump will spray. For example the customer can choose 4 spray cycles that last 1 minute each at an interval of 1 hour starting 12 hours from now. The control system will go to sleep after the system is armed only waking up to pump and spray the product. When the final pump cycle is completed the system will automatically power off. If the battery voltage drops below 9.5 volts for 30 seconds the system will power off. If the operator wants to interrupt the pump system after it has been armed, starting the engine will reset the display and controller.

Specifications for Automatic Pump Timer:

Countdown Timer: 0-24 Hours

Spray Duration: 2, 5, or 10 Minutes

Spray Number: 1-8

Spray Interval: 30 or 60 Minutes

**Output (auxiliary electric):**

The system also has an additional 12VDC output that can be used to operate a relay. It can be operated in manual mode, automatic mode, or timer mode. When in manual mode a button press on the DM430E will tell the MC38-10 to output power, this is a latching output that stays on until commanded off with a button press. Platform raise automatic mode will output 12 VDC if the display is in automatic mode, platform engage switch is on, and the platform raise button is pressed for 700 milliseconds. The output 12 VDC will stay on for 5 seconds, 10 seconds, or 15 seconds depending on which time option the customer has selected. Platform lower automatic mode will output 12 VDC continuously after the lower button is held for 200 milliseconds. It will stay on until the platform raise button is pressed for 300 milliseconds.

**Service Lights:** The MC38-10 controller will receive a CAN message from the DM430E display to turn on the service lights. When this message is “on” the output from the controller will be 12VDC on the light circuits.

**Diagnostic Information:**

Service Page 2 Valve Force will override all logic including seat switch. The only thing that can interrupt the output is the quickstop switch on the multifunction lever.

PWM output voltage: OP value 1800 is 2.56 VDC, OP value 3600 is 5.03 VDC, OP Value 6000 is 8.33 VDC

## SC1500 Platform Set-up Procedures

The diversity of specialty seed crops windrowed by the SC1500 platform require the consideration of several operating parameters before beginning to windrow a field.

Those parameters are:

1. Platform float pressure affects quality of cut, traction unit performance and wear and tear on the platform.
  - A. The larger the float pressure value the lighter the pressure will be on the ground, we typically run in the 900-1100 range.
  - B. If the pressure is too high, the platform will bounce excessively and cause a shaggy quality of cut, run just enough pressure to keep the platform engaging the ground.
  - C. If the pressure is too low, extra power will be consumed to push the platform, because it is not floating or following the ground and in crops like Fescue that can damage the plant crowns affecting next year's yield. Additionally it can decrease the life of the drive components of the cutterbar. Plus you will increase the amount of build-up under the cutterbar
2. Cutterbar angle affects quality of cut, knife wear, and the ability to divide cleanly on the end sheets.
  - A. Cutterbar angle is also critical for a clean cut and reduced shatter in lodged crops. When the crop is laying away from the cutterbar, more angle is required to prevent the cutterbar from running over the crop and leaving too much stem remaining on the ground. When laying into the cutterbar the angle needs to be reduced to cut the crop before it is contacting the converging drums and causing excessive shatter, and reduce damage to next years crop.
  - B. Cutterbar angle also affects a clean divide particularly in Turnips, Radish and Chicory. The knives on the end discs sweep against the cast iron insert in the end sheet to make a clean divide. When these large, dense, bushy crops are laying in to the platform, again reduce cutterbar angle to cut the crop earlier and enable a clean divide. When laying away the divide is not the issue but a clean cut is to increase the angle enough to cleanly cut off the crop.
3. Skid shoes gauges have 5 positions for varying conditions and crops. Remember the flatter you run the cutterbar the better it performs In most specialty crops position 1 or 2 is utilized, however in very short White Clover position 1 can help to cut cleanly and position 3 can be useful in tall crops. Remember to recheck cutterbar angle if the skid shoe position is changed.
4. Cutterbar configuration is also important to platform performance. The ability to add or remove accelerators on the discs and utilize two different knife pitches enable the operator to fine tune the performance of the platform and influence row formation.
  - A. In heavy or dense crops install accelerators on discs 2 & 9 and then 3 & 8 or install 18 degree knives. Check under windrow to verify knives are making a clean cut.
  - B. In shorter less dense crops accelerators may be removed and 10.5 degree knives used across the entire cutterbar to reduce lift and air so as to not cause the windrow to "blow up". It is recommended to remove the accelerators from the first disc on each side. Accelerators also have an "arrow" wear indicator and when the point is gone the accelerator needs to be replaced.
  - C. If you are uncertain how to begin in a new crop always start with 10.5 deg. Knives and no crop accelerators and then you can adjust from there.

## 5. Cutterbar Speed

A. Cutterbar speed is critical to performance. As a general rule enough speed is required to keep the knives fully extended (straight out) under full load. In nearly all seed crops that number is a minimum of 2800 RPM with 3000 RPM being optimum. When cutterbar speed drops and the knives are not fully extended the quality of cut will diminish and if the speed falls to far the knives will “Crash” causing them to hit each other and destroying their cutting surface. It is important to drive a speed that maintains knife speed as opposed to driving a fixed speed. If you are having difficulty maintaining knife speed check the wear on the knife. Once the square tip on the leading edge is worn off the knife will require flipping to the other side or replacement whichever is appropriate.

B. In short crops such as White Clover experience has shown that a cutterbar speed of 2400 RPM is appropriate in conjunction with a ground speed of 8 mph seems to produce the best row.

6. Converging drum speed is the last setting to consider and has the most impact on windrow quality. The SC1500 Platform has the ability to adjust drum speed to suit individual conditions.

A. For most crops the target speed is 1600 RPM. This is measured on the second suspended drum on each side. In lighter crops such as White Clover, the drum speed is more likely to be 800 RPM. 1600 RPM in most crops will work with ground speeds up to 12 mph. It may be necessary to adjust the drum speed to match ground speed in certain conditions. The ability to match drum speed to ground speed is unique to the SC1500 platform.

7. “Trust, but Verify”. When first starting a field check the quality of cut on each side of the field and make changes as necessary to insure a clean cut and smooth uniform windrow. How well this task is performed will determine how well the combine functions eight to ten days later.

## Calibration of Valves

Prior to calibrating of valves verify electrical connections from platform to traction unit are complete.

Select “MENU” from the selection on the bottom of the Hillco Monitor.

From the Menu Screen scroll down until “SERVICE” is highlighted and press  to enter.

Password for entering Service Screen is 18.

Arrow up until you have entered the number 18.

## PRESSURE SENSOR CALIBRATION

Preform this calibration with the **engine off**, key on.

From the Service Screen select “Pressure Sensor Calibration”

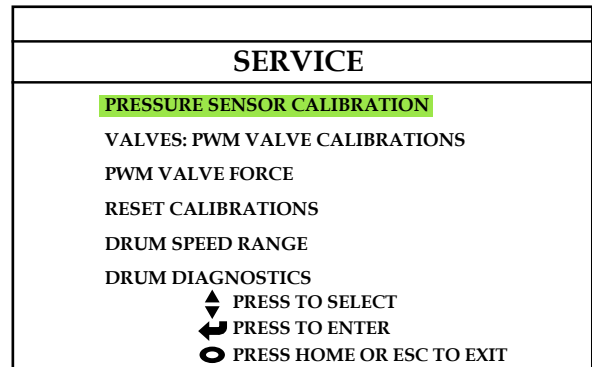
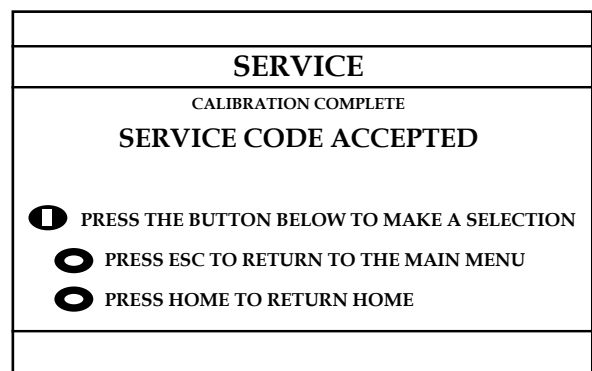
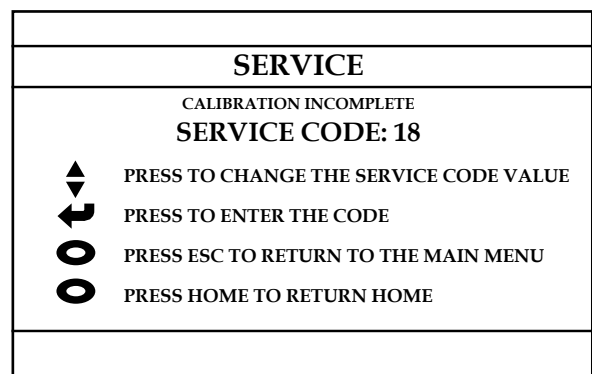
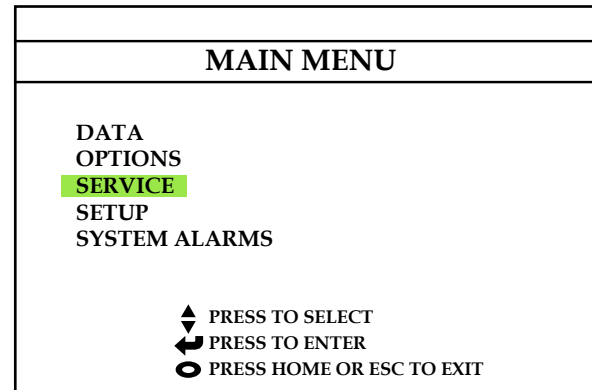
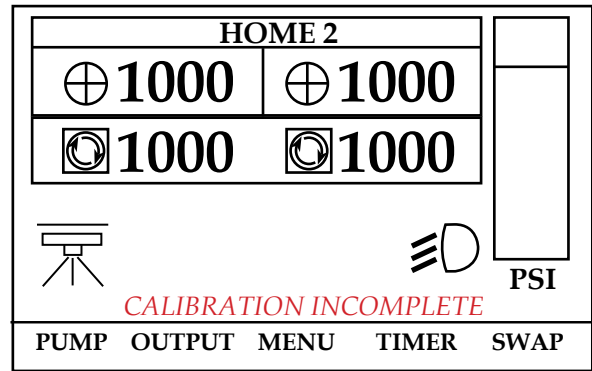

With the **Engine off** do the calibration procedure on the screen. This will match the electrical output of the sensors to the microprocessor.

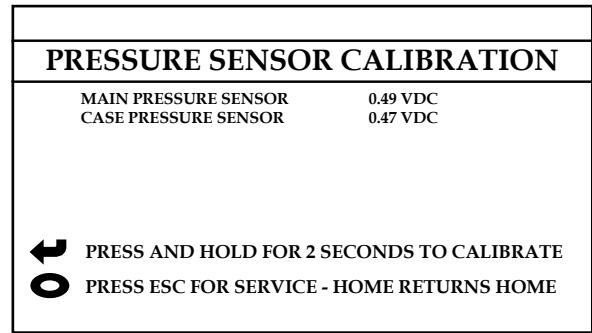

## VALVES: PWM VALVE CALIBRATION

From the Service Screen select “VALVES: PWM CALIBRATIONS”

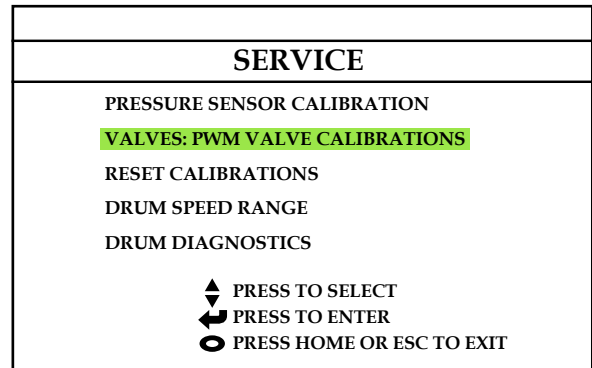

## Calibration of PWM Valves

After you complete the Pressure Calibration you will select PWM Start. Have engine at high idle but do not turn on the platform. Only the drums will turn. Press ARROW shown.

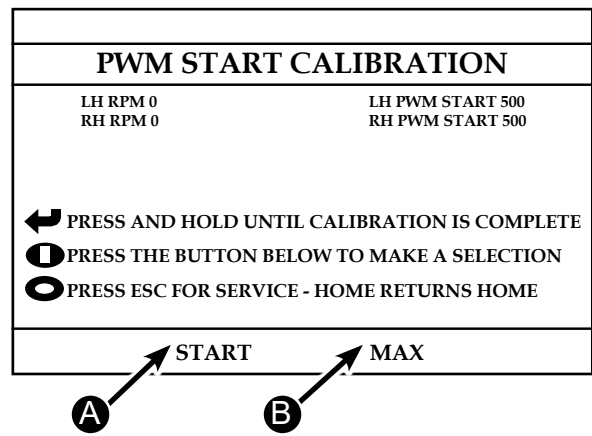

The platform does not need to be engaged. By holding down ARROW the system will start to activate the PWM valves increasing the PWM duty cycle until the drum speed is between 600-700 RPM.

During this time it is determining the voltage required to crack the valves open or start them. Screen will say Calibration complete.

After you complete the PWM start it will go to PWM Max. Again have engine high idle but do not turn on the platform. Only the drums will turn. Press ARROW shown. Calibration may take several minutes. Speeds will be around 1800-1900 rpms.

Screen will say Calibration complete.

You can select either START (A) or MAX (B) calibration first. By default it goes to the Start calibration first.

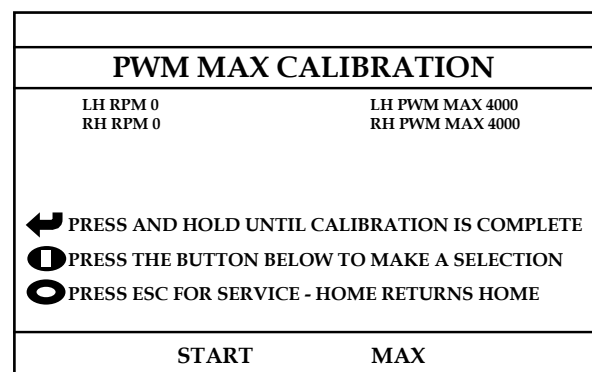

**NOTE: MAY TAKE SEVERAL MINUTES TO CALIBRATE MAX**

## Lubrication and Maintenance

### CAUTION

To prevent injury, never lubricate or service machine with engine running. Engine must be off and key removed.

### Grease

Use grease based on NLGI consistency numbers and the expected air temperature range during the service interval.

- **John Deere SD Polyurea Grease** is preferred. (TY6341)

The following greases are also recommended:

- John Deere HD Lithium Complex Grease (TY6333)
- John Deere HD Water Resistant Grease (TY24425)

Other greases may be used if they meet the following:

- NLGI Performance Classification GC-LB

**IMPORTANT:** Some types of grease thickeners are not compatible with others. Consult your grease supplier before mixing different types of grease.

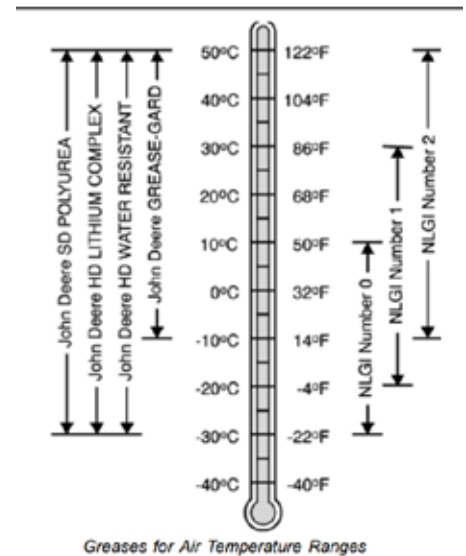

### Cutterbar Drive & Cutterbar oil

Use oil viscosity based on the expected air temperature range during the period between oil changes.

The following oil is preferred:

- **John Deere Hy-Gard™** (TY6354 - 1 gallon container)

Other oils can be used if they meet the John Deere

- Standard JDM J20C.

John Deere Low Viscosity Hy-Gard™ and BIO-HY-GARD™ oils are **NOT** recommended.

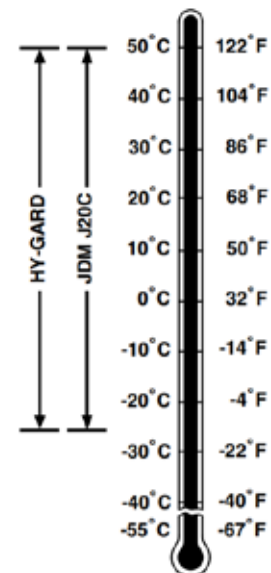

## Service Intervals

Service	Interval			
	Daily	First 50 hours	50 hours (Weekly)	150 hours (Yearly)
<b>X Required service interval</b>				
Clean cutterbar	X			X
Check Drum Driveshaft & Lovejoy Couplers	X			
Check or Inspect Drum Bearings	X			
Change cutterbar oil		X		X
Lubricate cutterbar driveline			X	
Check cutterbar oil level			X	
Check quill bearings				X
Change Return Filter				X
Change Case Drain Filter				X
Lubricate Lift Cylinder				X

### Daily Service

#### Clean Cutterbar

Before each use of machine, clean cutterbar.

**IMPORTANT:** Buildup of debris can cause excessive wear on cutting components and affect quality of cut.

Remove all crop material, dirt, mud, and debris from around cutterbar and cutting components.



### Daily Service

Inspect bearings on all eight drums (A). Visually look at upper and lower bearings on each drum to verify seal good.

Check Lovejoy couplers (B). Check for loose or missing setscrew, damaged or loose couplers, and wear or missing teeth on spiders.

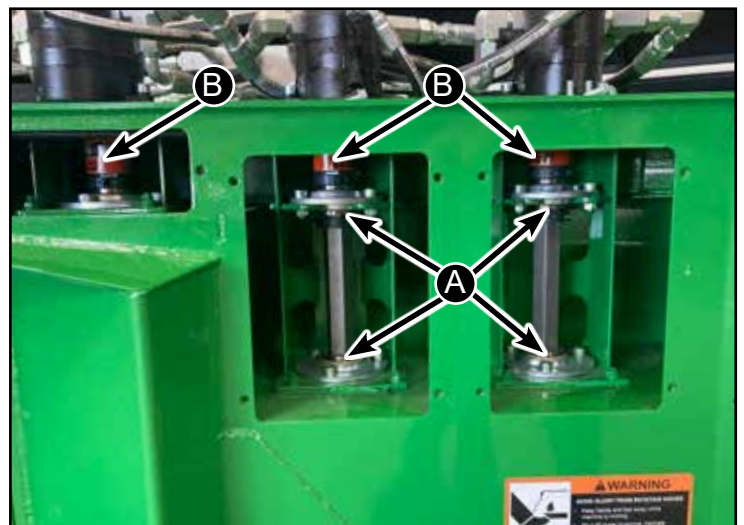

## Every 10 Hours Service

### Lubricate Drum Driveshaft

Every 10 hours of operation lubricate both drum driveshafts (A).

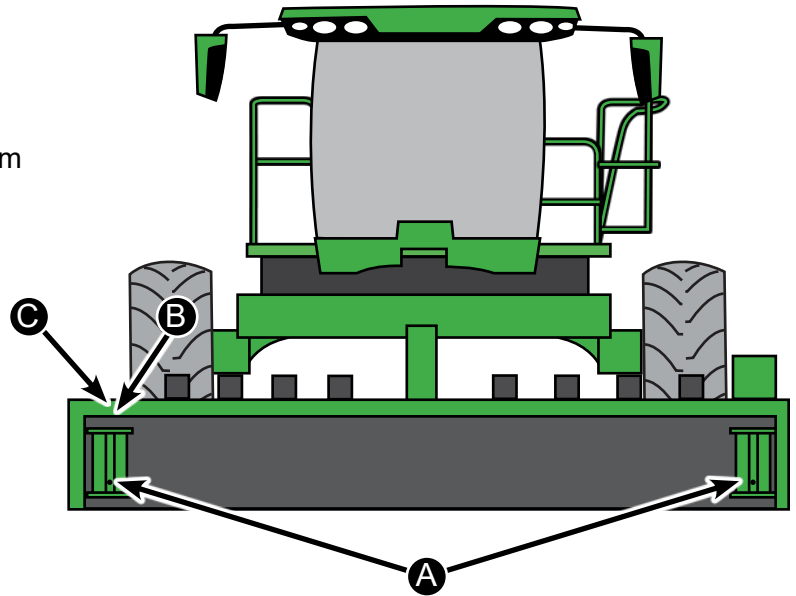

### Lubricate Drum 10 Carrier Bearing Assembly

Every 10 hours of operation lubricate retaining collar (C) and carrier bearing (B).

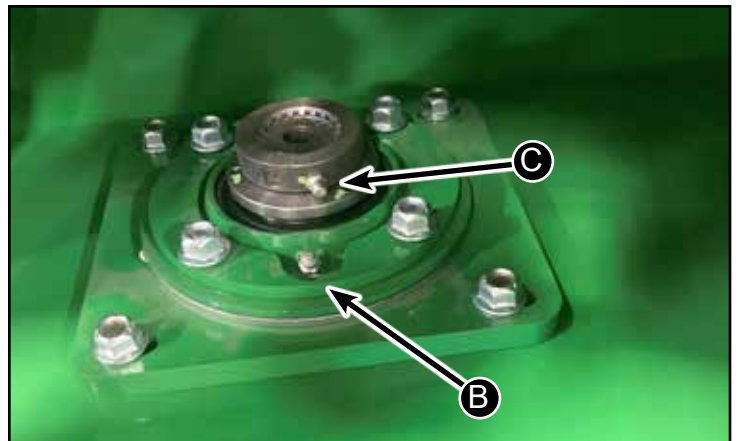

## Every 10 Hours Service

### Check Cutterbar Oil Level

1. Park machine on level surface, lower platform, and tilt platform to flattest angle.
2. Remove key.
3. It is necessary for the platform to be as level as possible.
4. Level platform side-to-side by using a jack under low end.
5. Give oil time to level out.
6. Check Oil Level through sight glass (A) on each side.
7. Required level in sight glass is 1/3 full. Follow diagram
8. Use oil viscosity based on the expected air temperature range during the period between oil changes. (See next page for adding oil).

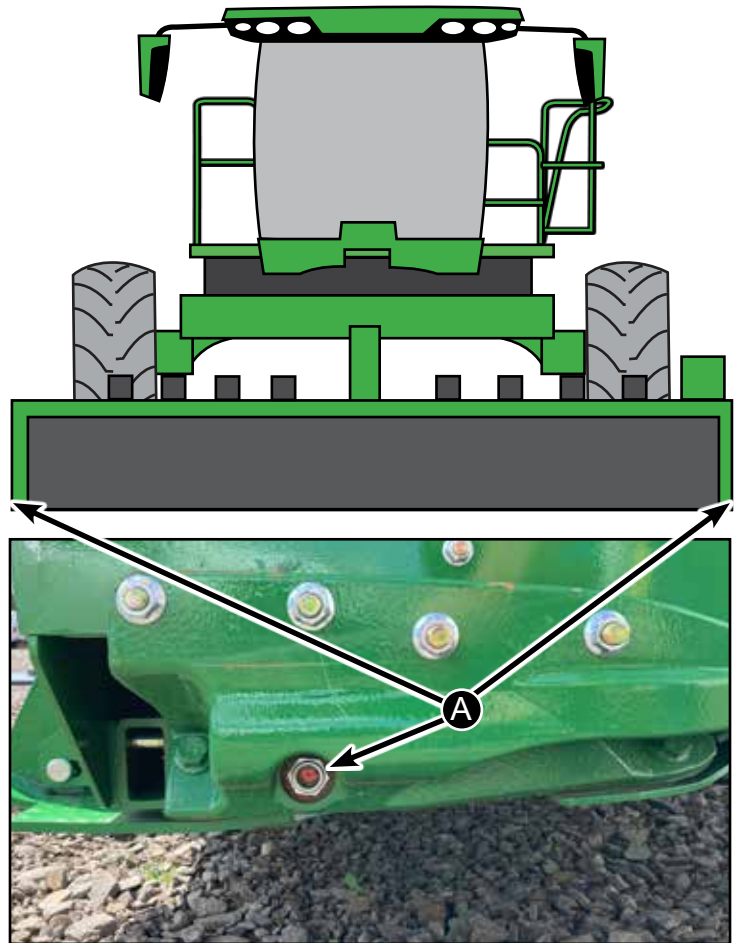

A - Sight Gauge

The following oil is preferred:

- **John Deere Hy-Gard™**

Other oils can be used if they meet the John Deere Standard JDM J20C.

John Deere Low Viscosity Hy-Gard™ and BIO-HY-GARD™ oils are **NOT** recommended.

Oil shows 1/3 full in both sight glasses= correct oil level.

Oil shows full in both sight glasses= too full

No oil in either sight glass= too low

One sight glass full one empty= level the machine and recheck.  
Having the machine level is very critical to the cutterbar oil level. (See next page for adding oil)

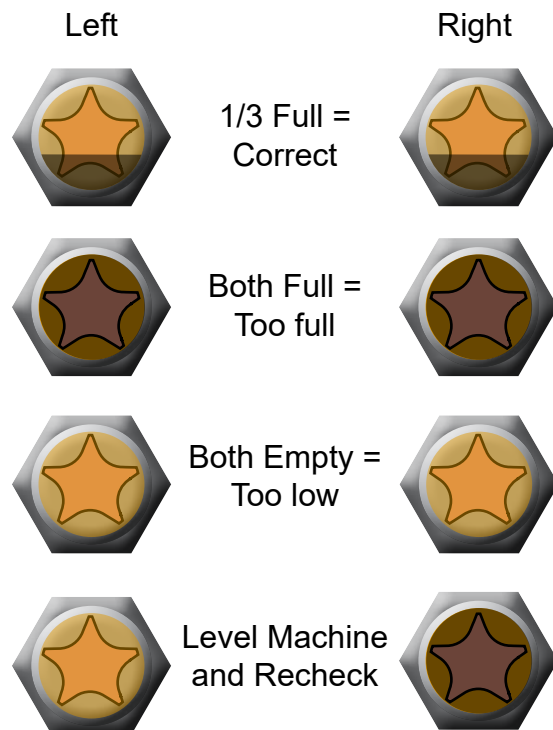

## Adding Oil Cutterbar

1. Remove shield (A).
2. Remove filler plug (B).
3. Add John Deere Hy-Gard™ oil, or equivalent.
4. Install filler plug (B) and close door.



## Every 50 Hours Service (Weekly)

### Lubricate Driveline

Every 50 hours of operation lubricate cutterbar driveline.

1. Remove Shield (A)
2. Lubricate grease fittings (B). (2 Grease Zerks)
3. Replace Shield

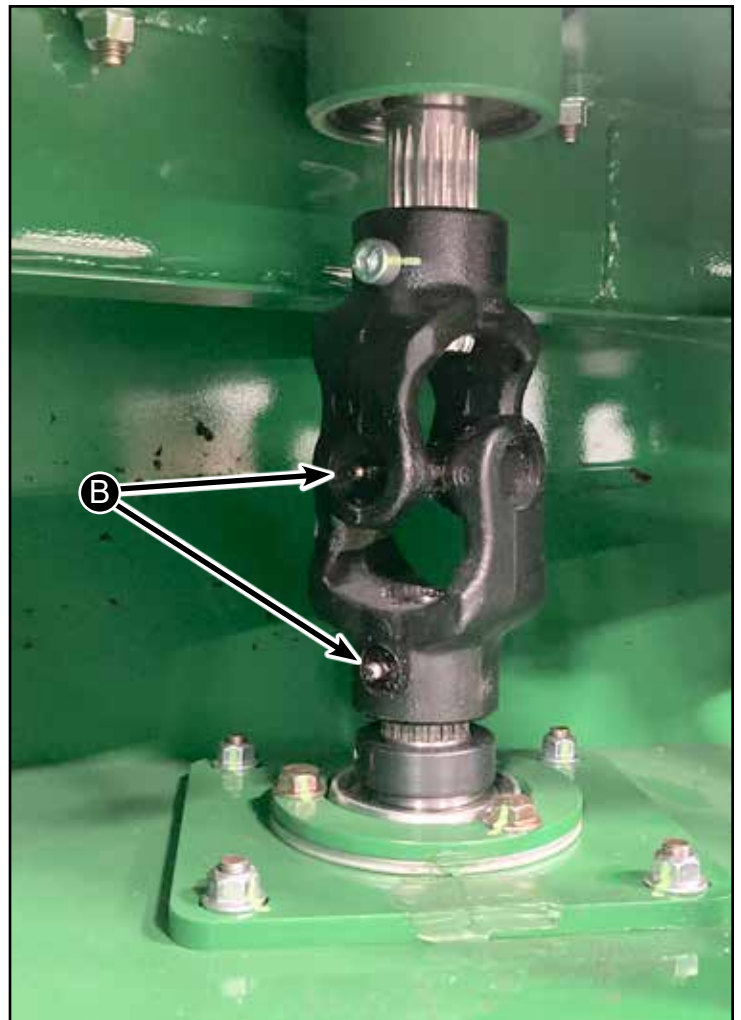

## First 50 Hours Service

### Change Cutterbar Oil

First 50 hours of operation, change cutterbar oil.

1. Park machine on level surface, lower platform, and tilt platform to flattest angle.
2. Run machine to warm cutterbar oil.

### CAUTION

Prevent bodily injury or death. Do not work under or around raised platform without engaging lockout lever. Raise platform, engage platform lift lockout lever, turn off engine, and remove key.

3. Raise platform and engage platform lift lockout lever. Turn off engine and remove key.
4. Position three 150 x 150 mm (6 x 6 in.) wooden blocks, stacked on top of each other, under right-hand side of platform.
5. Position one 150 x 150 mm (6 x 6 in.) wooden block under left-hand side of platform.
6. Place a 15.1 L (4 gal.) container under cutterbar sight glass (A).
7. Loosen sight glass with 7/8 in. socket. Do not remove at this time.
8. Lower platform onto wooden blocks. Turn off engine and remove key.
9. Remove sight glass to drain oil.
10. Install sight glass after oil has been removed and tighten to specification.

#### Specification

Sight glass—Torque.....65 N·m  
(48 lb.-ft.)

11. Raise platform and engage platform lift lockout lever. Turn off engine and remove key.
12. Remove wooden blocks.
13. Lower platform.
14. Open door at left-hand side of machine to access fill plug (B). (continued on next page)

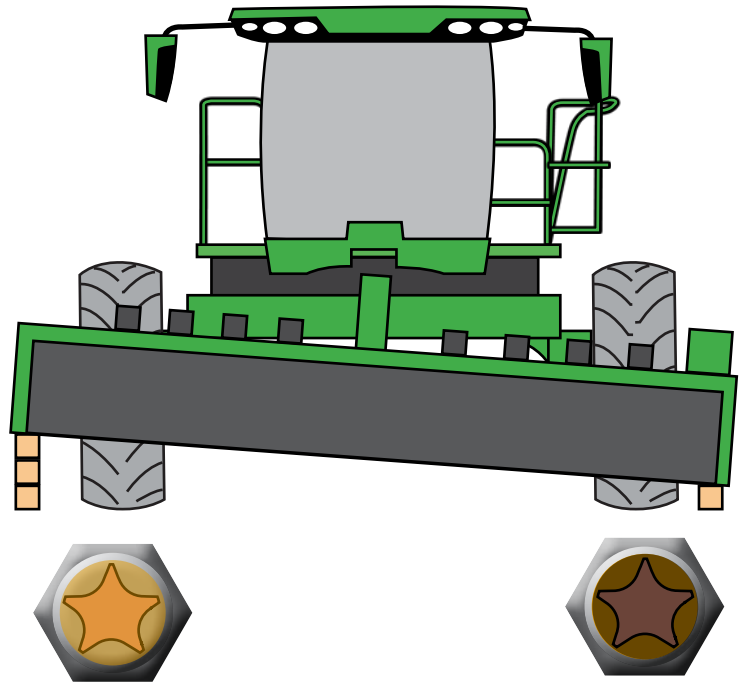

A - Sight Gauge



B - Fill Plug

Specification

Cutterbar - Capacity.....11.5 L  
(12 qt)

**IMPORTANT: Too much oil in cutterbar can cause overheating and cutterbar damage**

15. Use sight glass at both ends of cutterbar to check oil level.

16. Level platform side-to-side by using a jack under low end. Give oil time to level out.

17. Check oil level in sight glasses (A) on both sides of machine.

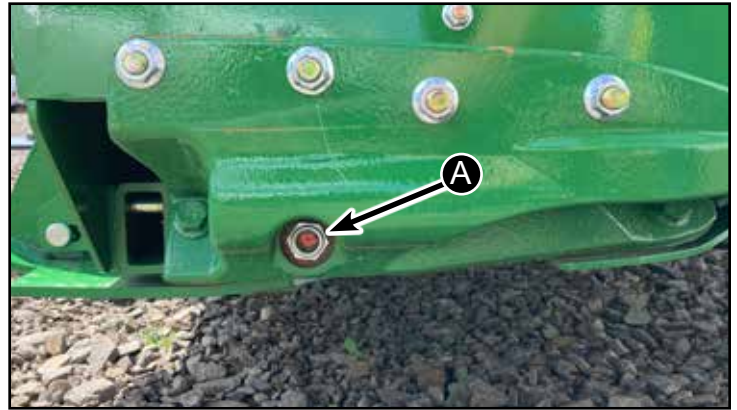

A - Sight Gauge

Oil shows 1/3 full in both sight glasses = correct oil level.

Oil shows full in both sight glasses= too full

No oil in either sight glass= too low

One sight glass full one empty= level the machine and recheck.  
Having the machine level is very critical to the cutterbar oil level. (See next page for adding oil)

18. Remove filler plug (B).

19. Add John Deere Hy-Gard™ oil, or equivalent.

20. Install filler plug (B) and reinstall cover.

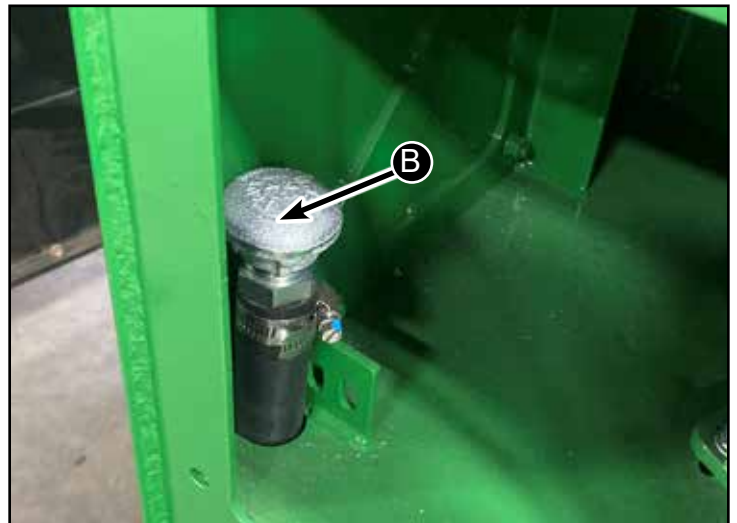

B - Fill Plug

## Supplemental instructions for Checking Cutterbar Oil

Move machine to a level surface. Retract the top link fully. Lower the platform to the ground.

Check both of your sight gauges on each end. They should both show no oil in sight glass.

Now raise the platform and put a 2" block under the platform at one end.

Wait 5 minutes for oil level to equalize.

The sight gauge on the other end should be full.

The sight gauge on the 2" raised end should be empty.

Sight gauge will usually show a small amount trapped in the gauge.

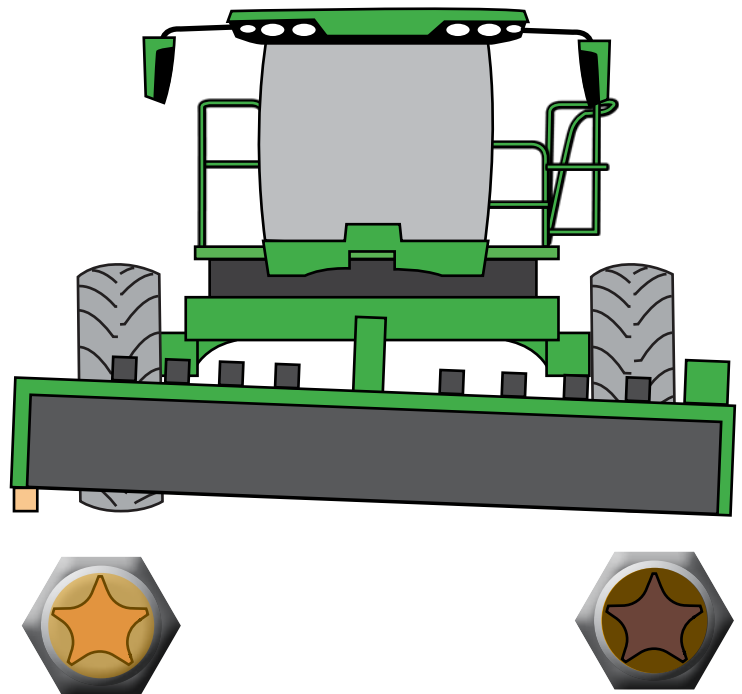

### Alternative Method

If you are not sure of the level of oil in the cutterbar you can drain it out by lifting one end and pulling the sight gauge.

Measure what came out for verification.

If you drained overnight refill with 12 qts of HYGARD

If you drained and want to refill quickly, use 10.5 qts. of HYGARD

## Every 150 Hours Service Or Seasonal

### Lubricate Knockdown Lift Cylinder

Every 150 hours of operation lubricate knockdown lift cylinder (B).

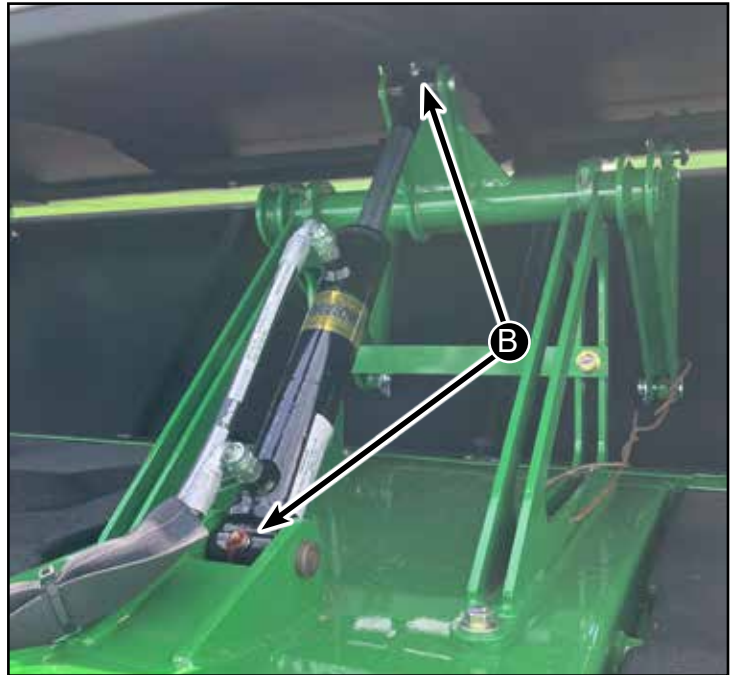

## Every 150 Hours Service or Seasonal

### Change Cutterbar Oil

Every 150 hours of operation, change cutterbar oil.

1. Park machine on level surface, lower platform, and tilt platform to flattest angle.
2. Run machine to warm cutterbar oil.

### CAUTION

Prevent bodily injury or death. Do not work under or around raised platform without engaging lockout lever. Raise platform, engage platform lift lockout lever, turn off engine, and remove key.

3. Raise platform and engage platform lift lockout lever. Turn off engine and remove key.

4. Position three 150 x 150 mm (6 x 6 in.) wooden blocks, stacked on top of each other, under right-hand side of platform.

5. Position one 150 x 150 mm (6 x 6 in.) wooden block under left-hand side of platform.

6. Place a 15.1 L (4 gal.) container under cutterbar sight glass (A).

7. Loosen sight glass with 7/8 in. socket. Do not remove at this time.

8. Lower platform onto wooden blocks. Turn off engine and remove key.

9. Remove sight glass to drain oil.

10. Install sight glass after oil has been removed and tighten to specification.

#### Specification

Sight glass—Torque.....65 N·m  
(48 lb.-ft.)

11. Raise platform and engage platform lift lockout lever. Turn off engine and remove key.

12. Remove wooden blocks.

13. Lower platform.

14. Open door at left-hand side of machine to access fill plug (B). (continued on next page)

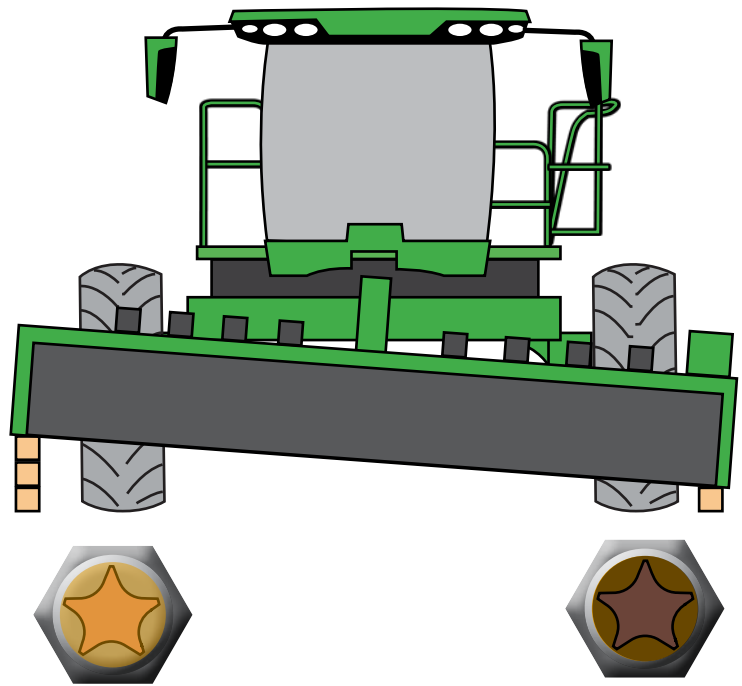

A - Sight Gauge



B - Fill Plug

Specification

Cutterbar - Capacity.....10 L  
(10.5 qt)

**IMPORTANT: Too much oil in cutterbar can cause overheating and cutterbar damage**

15. Use sight glass at both ends of cutterbar to check oil level.

16. Level platform side-to-side by using a jack under low end. Give oil time to level out.

17. Check oil level in sight glasses (A) on both sides of machine.

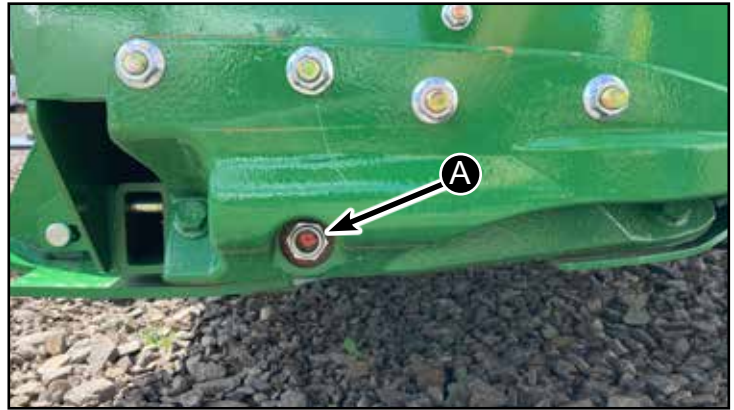

A - Sight Gauge

Oil shows 1/3 full in both sight glasses = correct oil level.

Oil shows full in both sight glasses= too full

No oil in either sight glass= too low

One sight glass full one empty= level the machine and recheck.  
Having the machine level is very critical to the cutterbar oil level. (See next page for adding oil)

18. Remove filler plug (B).

19. Add John Deere Hy-Gard™ oil, or equivalent.

20. Install filler plug (B) and reinstall cover.



## Every 150 Hours Service or Yearly

Every 150 hours of operation replace return oil filter (A) & case drain filter (B).

Return filter (A) and Case Drain filter (B) are located under machine below operator's station (C).

Replace with John Deere Oil Filter Part No AH128449

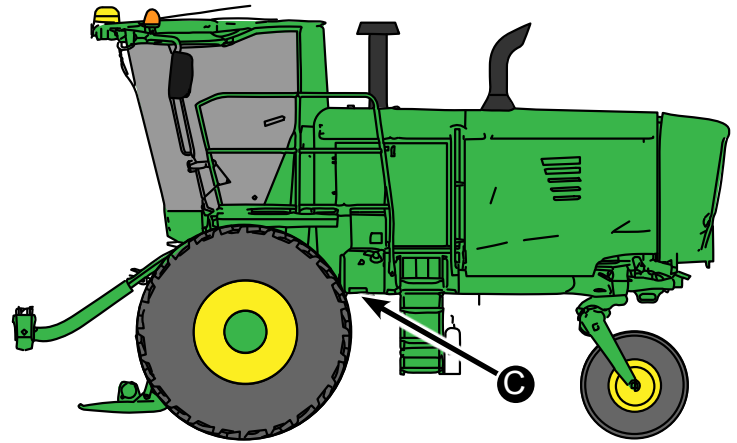

### CAUTION

Do NOT attempt to remove or service hydraulic oil filters while engine is running.

NOTE: Place a bucket under machine frame below hydraulic filters.

1. Remove filters.
2. Apply a light coat of hydraulic oil to seal before installing new filter.
3. Tighten filter until filter seal contacts mounting surface. Tighten an additional 1/2 turn.

### CAUTION

Do NOT check filter seal for leaks when engine is running.

4. Sound horn, start engine, and allow to run for several minutes.
5. Turn off engine and remove key, wait a few minutes, and visually check filter seal for leaks.

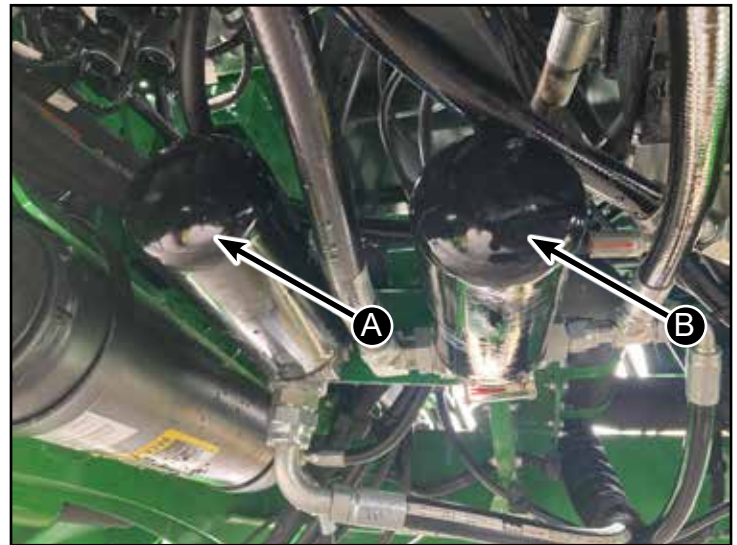

A - Return Filter (AH128449)  
B - Case Drain Filter (AH128449)

### NOTE

When removing the filters all of the oil in the reservoir can drain. Replace filters quickly to minimize loss or drain system.

## Every 150 Hours Service or Yearly

Every 150 hours of operation, clean cutterbar.

### CAUTION

Prevent bodily injury or death. Do not work under or around raised platform without engaging lockout lever. Raise platform, engage platform lift lockout lever, turn off engine, and remove key.

**IMPORTANT:** Buildup of debris can cause excessive wear on cutting components and affect quality of cut.

Remove all crop material, dirt, mud, and debris from around cutterbar and cutting components.

## Check Quill Bearings

Every 150 hours of operation check quill bearings on cutting disks.

Note: On disks 1 & 10 remove the 3 bolts on the pressed flange housing on each side holding the top bearing (A) so the quill bearing can be checked. These bolts are removed to allow for movement at the top of the drum.

Use a dial indicator (B) to check the quill bearing rock at the end of the disk. If disk rocks more than a total of .08" replace quill bearing.

### Specification

Disk Rock Tolerance..... 2 mm  
(0.08 in.)

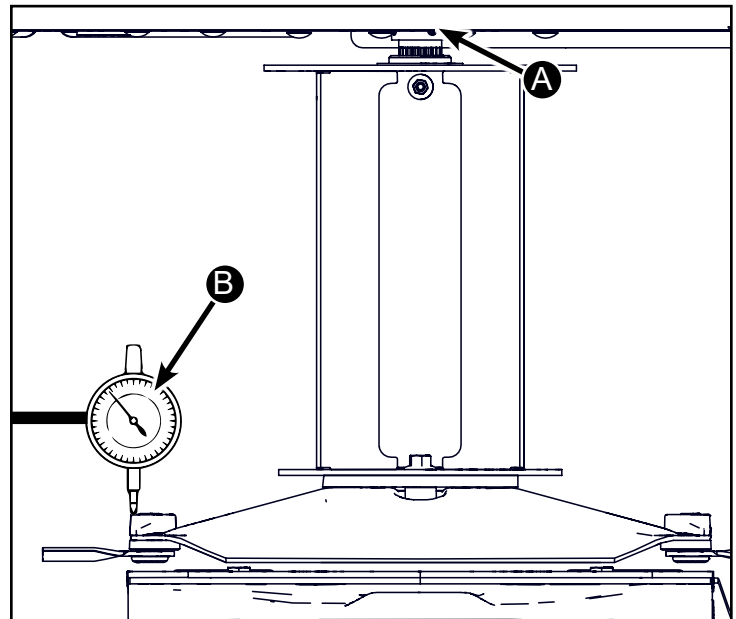

## Service

### Hanging Drum Removal

#### CAUTION

Ensure that the header safety lock is secure, and header is locked out.

Removal (Estimated Time of Repair 20min)

Remove the rear shield (A) (13mm Socket) – Utilize magnetic tray to hold hardware.

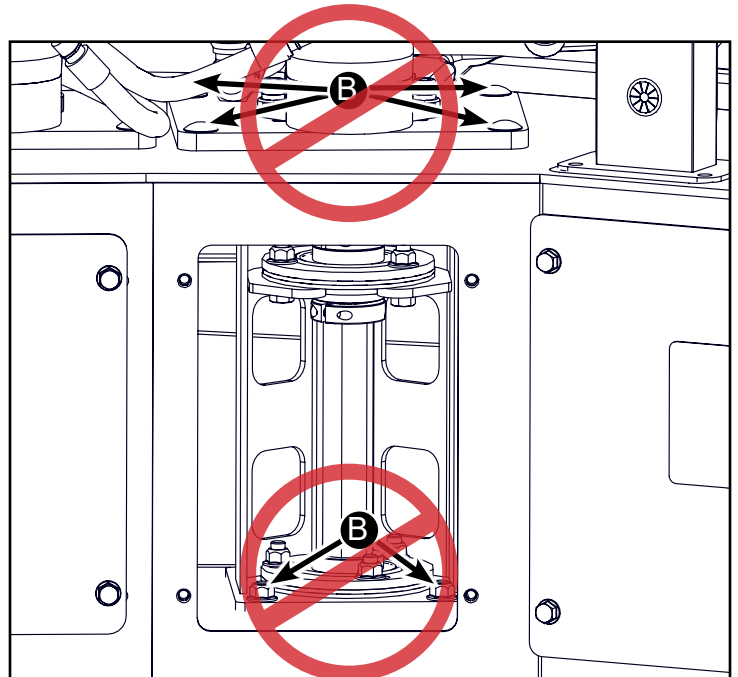
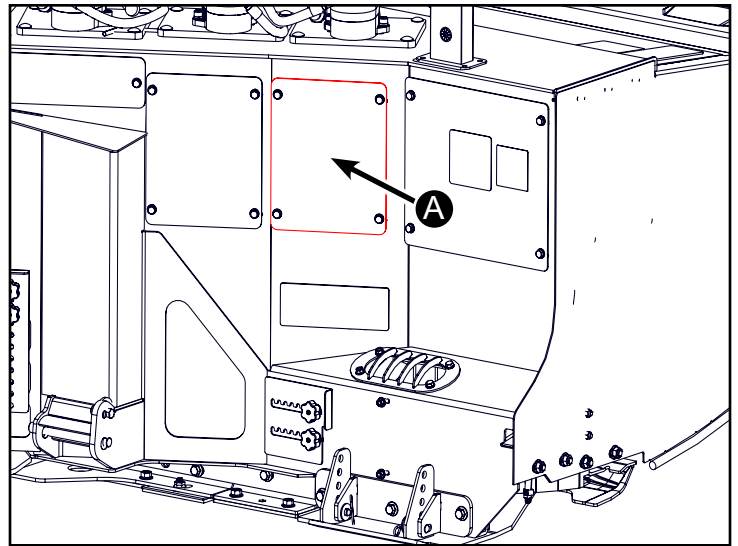

**DO NOT LOOSEN OR REMOVE THE 8 BOLTS (B) THAT SECURE THE BEARING TOWER. LOOSENING FOR REMOVING THESE BOLTS COULD RESULT IN DAMAGE IF TOWER MOVES AND IS NOT PROPERLY REALIGNED.**

Remove the hydraulic motor (C) (8mm Allen Wrench or Allen Socket). It is not necessary to disconnect the hydraulic hoses.

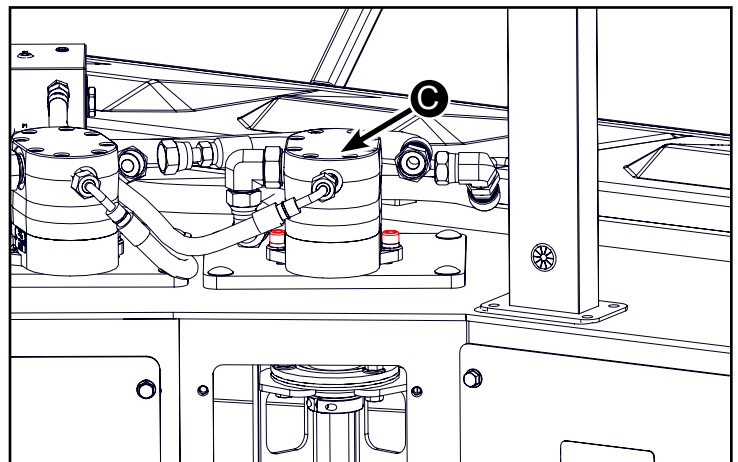

Inspect the condition of the spider (A). Replace if worn.

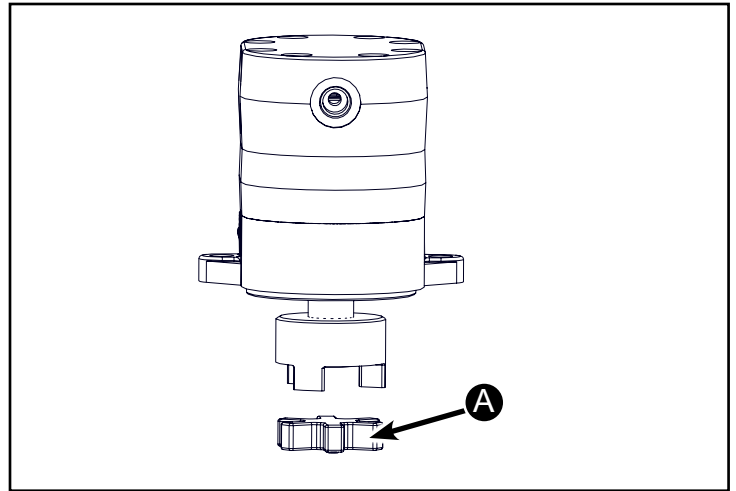

Remove the Lovejoy (B) from the hanging drum shaft (1/8" Allen Wrench)

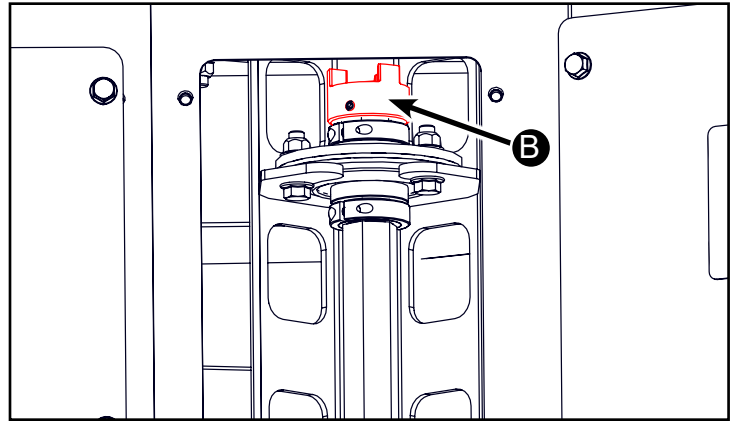

Remove square stock key (C) from the shaft or love joy.

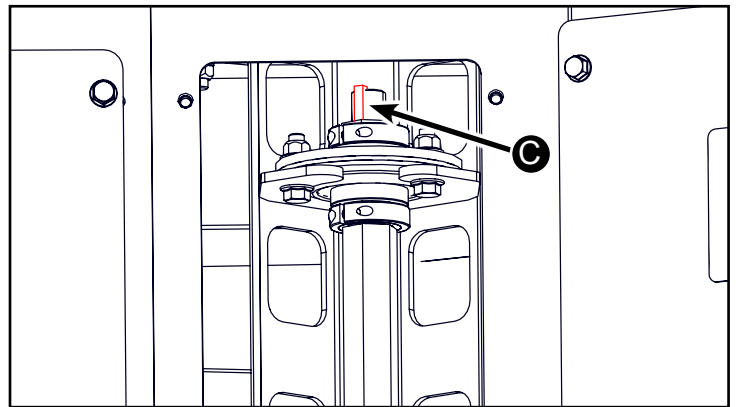

Remove the lower split collar (D) from the shaft (3/16" Allen Wrench)

Remove the upper split collar from the shaft (E) - The drum may drop when this is done, be sure to support drum and lower by hand once collar is removed.

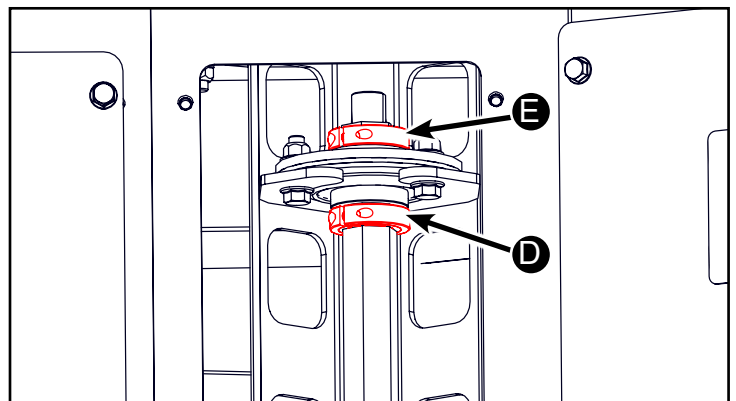

Remove the nuts and bolts (A) from the upper bearing flangettes (15mm wrench/socket) (Note: If just replacing the upper bearing, this can be done now).

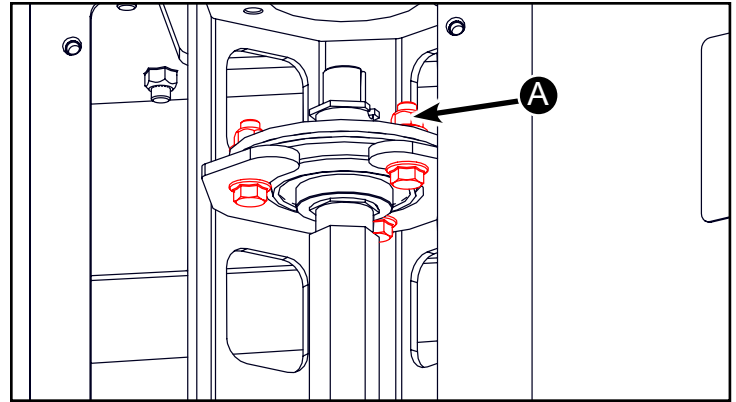

Remove top clamp (B), flangettes (C) and bearing (D).

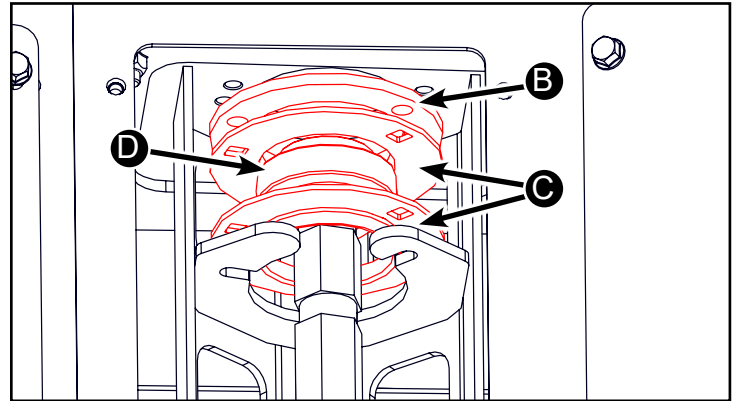

Remove the nuts and bolts (E) from the upper bearing flangettes (15mm wrench/socket)

Remove top clamp (F), flangettes (G) and bearing (H).

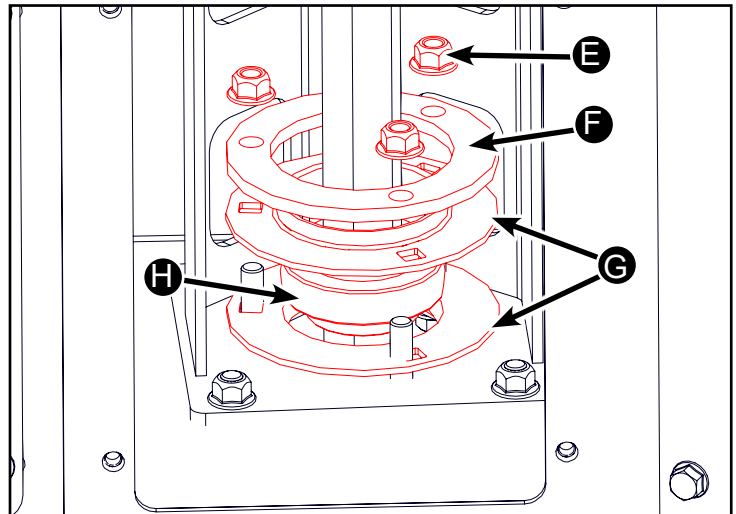

Lift drum slightly (this may be easier from the front of the header) and tip the shaft rearward remove the bearing and flangettes.

Go to the front of the header and lift the drum off the cutter bar, tilt the base towards the front, and slide the drum and shaft out of the header.

## Hanging Drum Repair

Loosen but do not remove bolt (A) on bottom of hanging drum shaft.

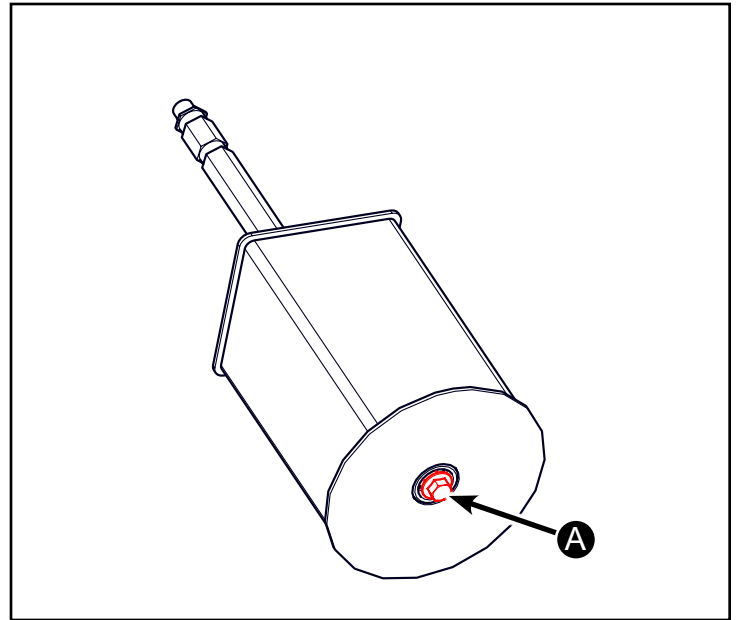

Support the Drum (B) upside down and using a dead blow hammer (C) or copper punch (D), drive on the bolt head so that the threads in the shaft are not damaged. Once the shaft breaks free, remove the shaft (E).

If replacing the shaft or the drum, ensure that all paint is removed from the inside hex of the drum, both top and bottom.

Apply Anti-Seize compound to the hex of the drum.

Insert the top of the shaft through the bottom of the drum and install the hanging drum washer bolt, then tighten the hanging drum bolt.

*Torque M16 bolt to 225 ft-lbs.*

Using a dead blow hammer, drive the shaft through the hanging drum, ensuring that the washer is inside and fully seated within the bottom hex recess.

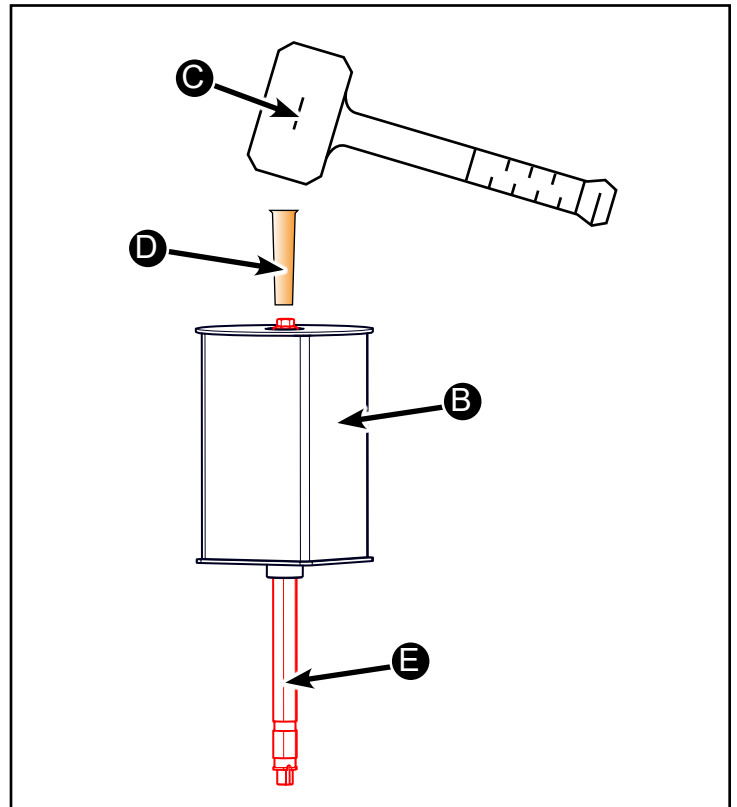

## Hanging Drum Installation

(Estimated Time of Repair 40min)

From the front of the header position the hanging drum (A) on the cutter bar with the shaft through the bearing hole and then move to the rear of the header.

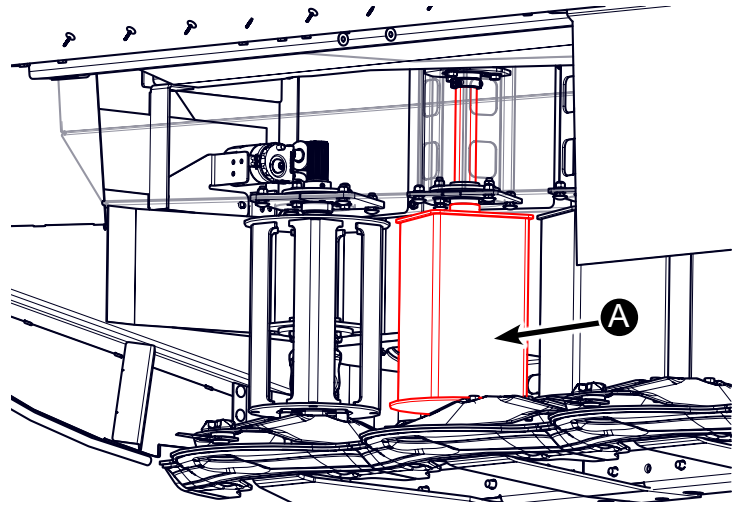

Set the bottom flangette (B), the bottom bearing (C), top flangette (B) and flangette stiffener ring (D) over the shaft and slide them into position on the frame. Install nuts (E) but do not tighten nuts at this time.

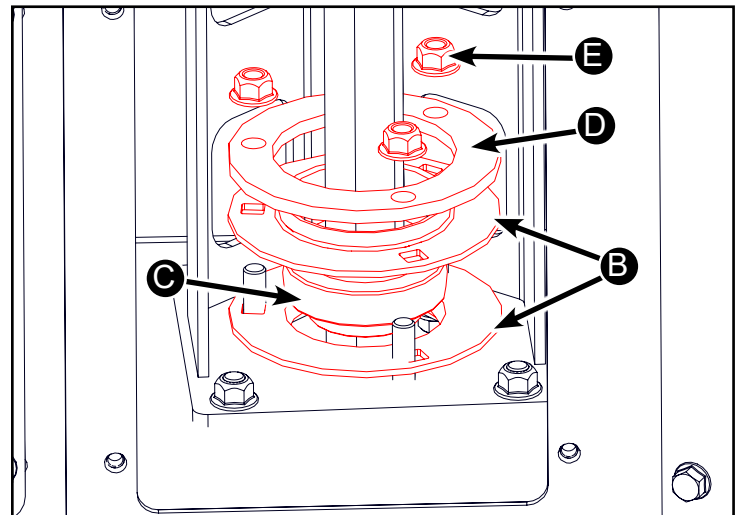

Set the top bearing bottom flangette (F), top bearing (G), top bearing flangette (F) and the flangette stiffener ring (H) on the shaft and position it into the top bearing location on the frame.

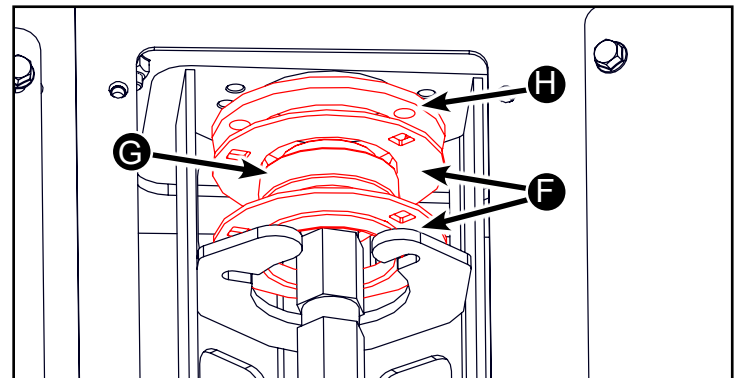

Now grasping it firmly, lift the shaft with one hand till you can install one half of the top split collar (I) into the collar groove on the shaft. (Note – ensure split collar grooves are up).

This will hang the drum in position.

Install the other half of the split collar, (Note – ensure split collar grooves are up). Apply Loctite 243 (Blue) to the split collar screws and tighten the Allen head screws.

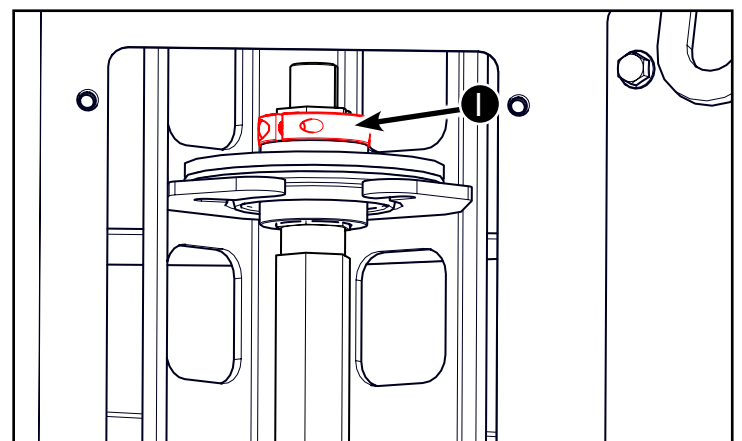

Install the bottom split collar (A), again using Loctite 243 on the threads and tighten the Allen head screws. (Note – ensure split collar grooves are up).

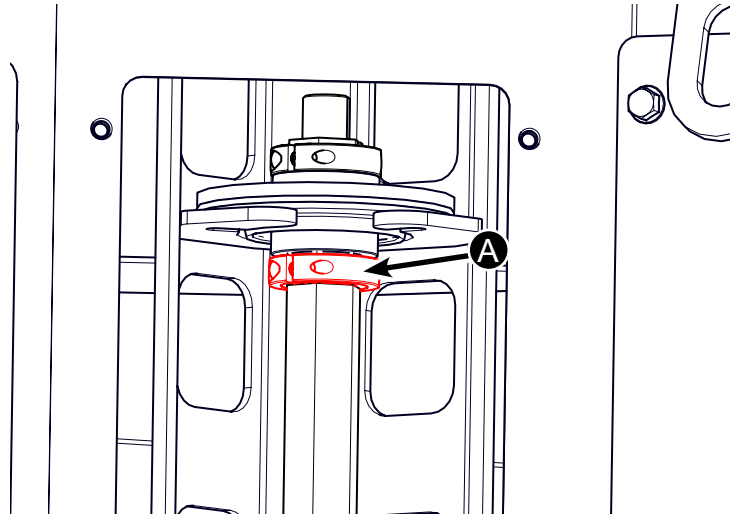

Loosely install stover nuts and bolts in the upper bearing flange holes. (Note: if holes were damaged for any reason, flanges can be rotated to a secondary hole position)

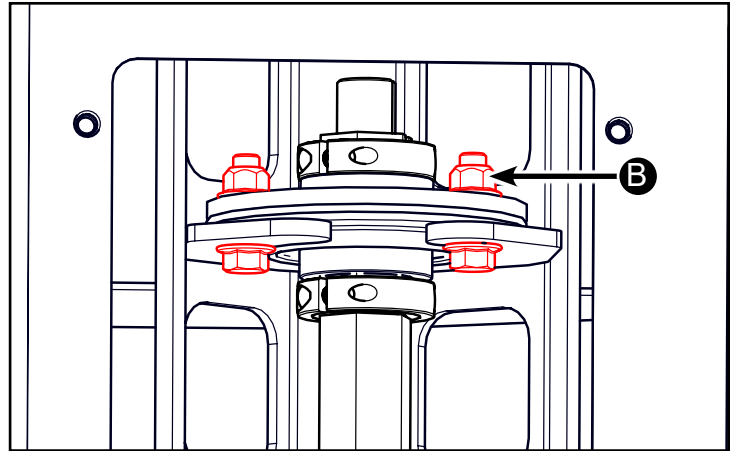

Utilizing the Hillco Technologies Drum Alignment Tool (C) PN J13971, push it down until it seats on the motor mount with the hex drum shaft in the alignment hole.

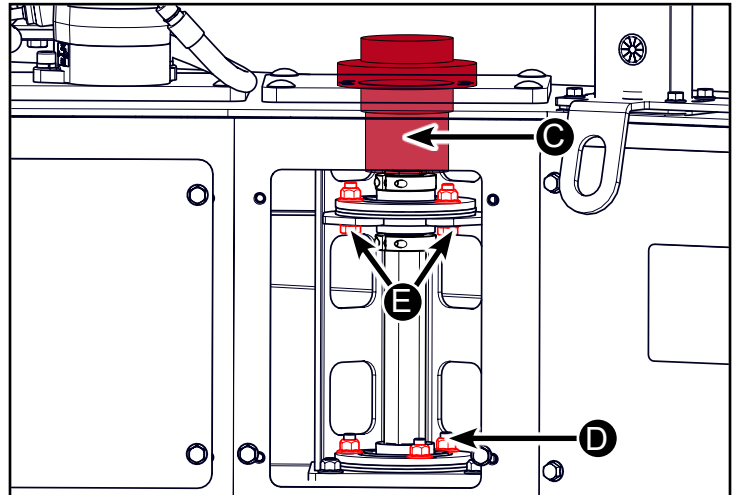

Tighten the lower bearing bolts (D) and the rearward two top bearing bolts (E)

Remove the Alignment tool (C) and tighten the third bearing bolt located toward the front of the machine

*Bolt Torque Specification 80ft-lbs*

Install square stock key (F), ensuring that it does not protrude above the top of the shaft.

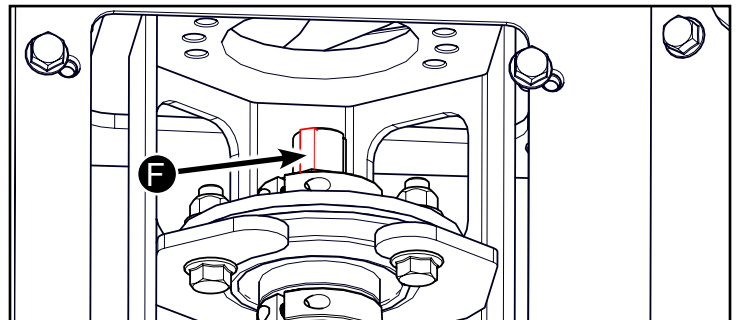

Install the top love joy (A) – utilize the Hillco Technologies Lovejoy Installation tool (B) to ensure not to damage Lovejoy. Seat this love joy all the way to the shoulder on the shaft. (DO NOT TIGHTEN SET SCREW AT THIS TIME) -

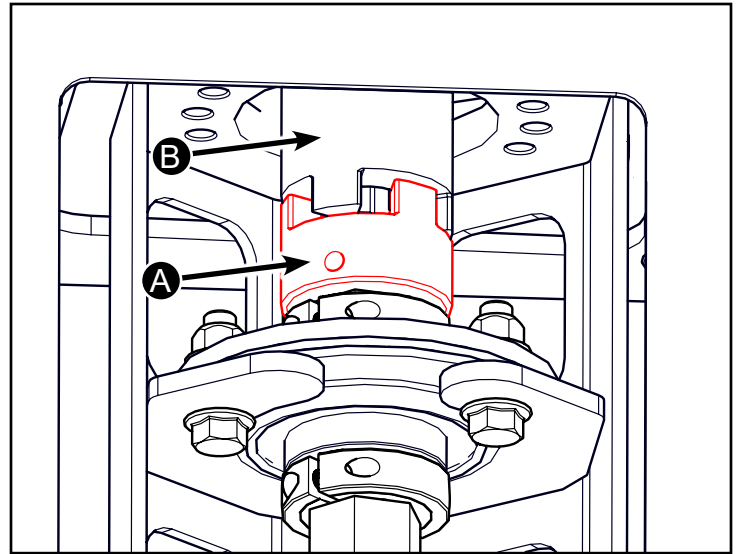

Set the motor in place and adjust the distance between the love joy on the motor (C) and the love joy on the shaft to 1/8" (+/- 1/16"). It may be necessary to loosen the top love joy. Tighten the love joy set screws.

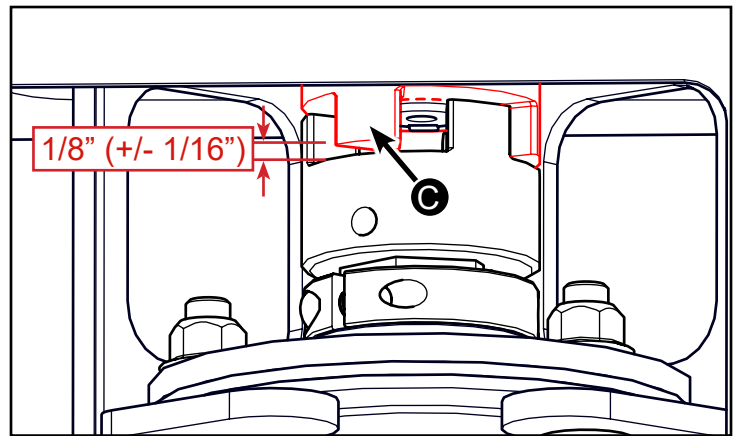

Lift motor back out and install the spider (D). Ensure that the cupped side of the spider faces either the shaft or the motor, depending on which side had the most shaft protruding.

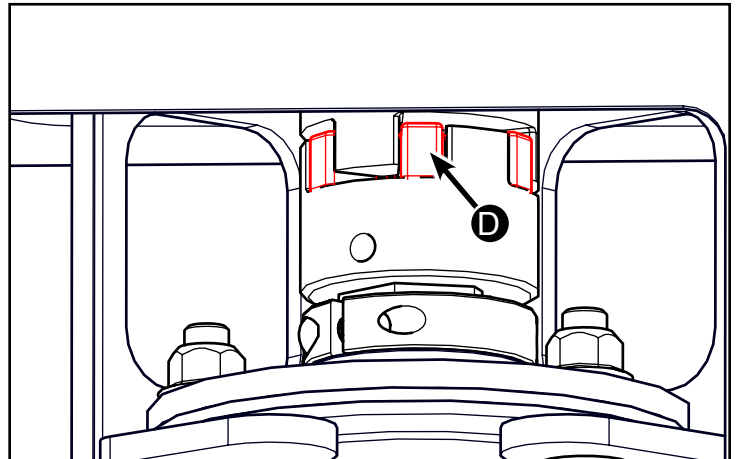

Install the motor again, rotating the hanging drum shaft by hand to get proper alignment and install and tighten the motor mount bolts. (Note: if bolts do not have lock washers, utilize Loctite 243 on the threads).

## Replace End Disk Driver (A)

Park machine on level surface.

### CAUTION

Prevent bodily injury or death. Do not work under or around raised platform without engaging lockout lever.

Raise platform, engage platform lockout lever, turn off engine, and remove key.

### CAUTION

Knives have two sharp cutting edges and can cause serious injury. Wear gloves when handling knives.



Remove the 4 M8 bolts and remove service cover (B) with a 13mm socket.

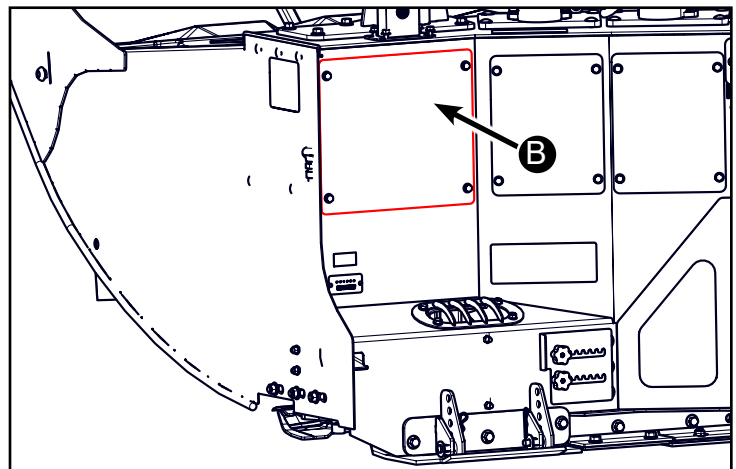

Remove the (4) motor drive mounting bolts (16mm), lift and set motor to side, ensure not to step on spray nozzle connections. (Prybar may be necessary).  
Note: Motor is Heavy, use proper lifting technique

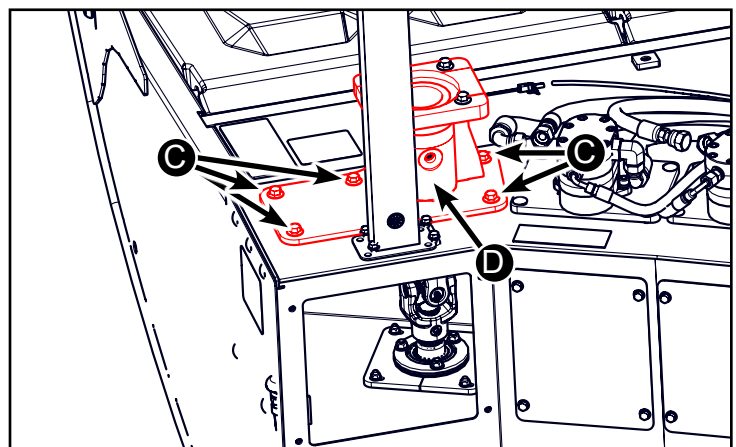

Remove the 5 M12 bolts (C) 16mm & 17 socket/wrench and pull the motor mount (D) upwards and set it to the side.

Note: Top of splined driveshaft will flop downwards when motor mount is removed.

Loosen the lock collar (A).

Remove the 3 M10 Bolts (B) that hold the bearing flangettes to the split bearing mount plate. (15mm)

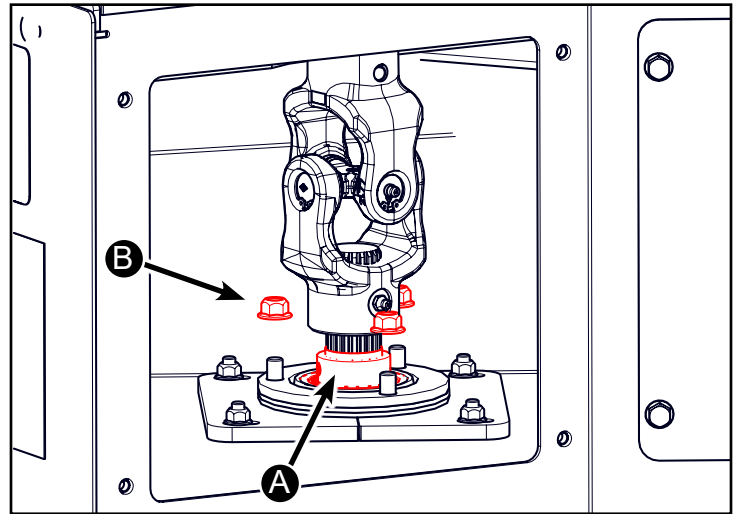

Rotate the end drum around to access the bolt (C) that retains the shaft into the U joint. To remove this bolt a nut and bolt (D) for the flanged drum will have to be removed.

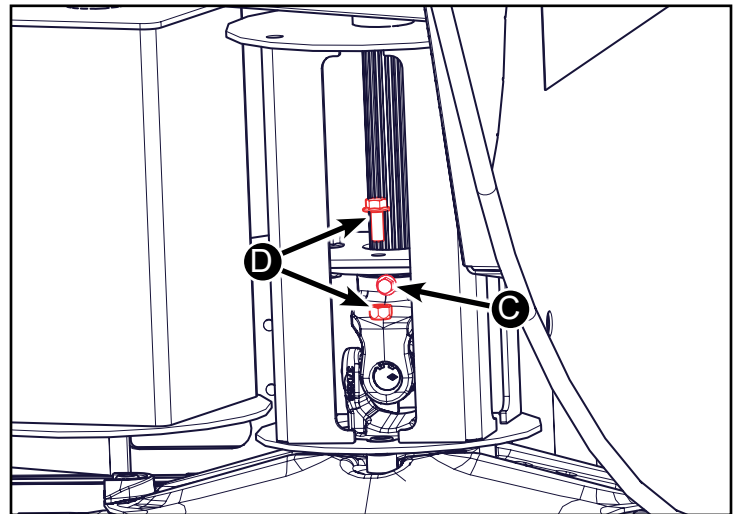

Remove the (4) M12 Socket Head Cap screws (E) that hold the drum to the disk. 10mm Hex Head

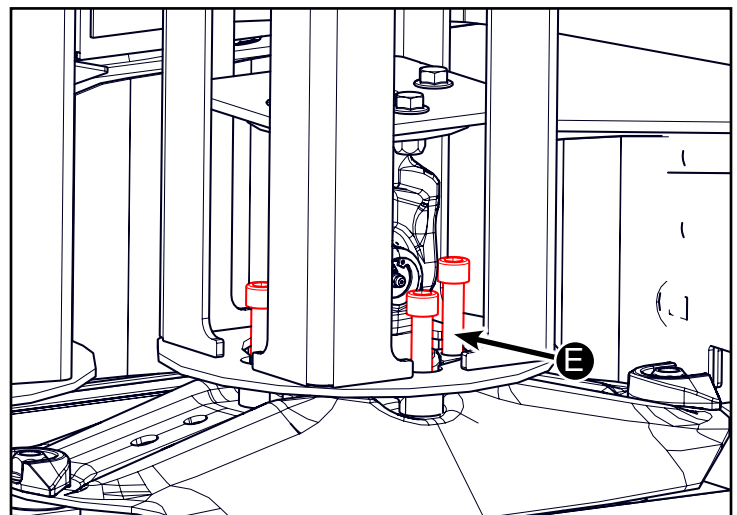

The drive shaft (A) will lift upwards out of the drum (B).

The drum can then be removed out the front of the head.

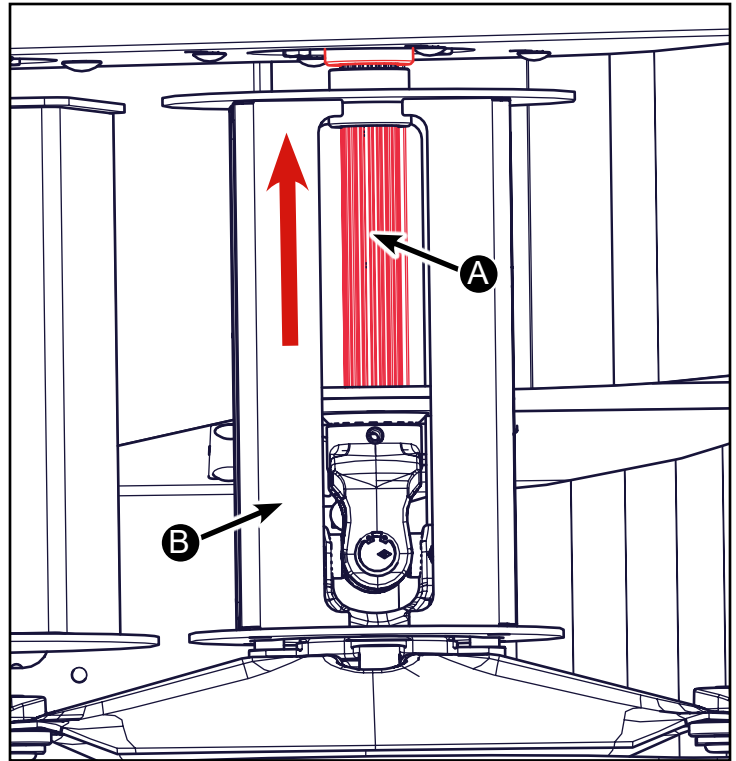

Lower edges of disks wear to sharp edges. Sharp edges can cause serious injury. Wear gloves when handling disks.

To avoid serious injury, rotate both knives on all disks, so they are positioned UNDER disks.

Remove disk (C).

Hardened cap screw contains an encapsulated thread lock compound on threads. Hardened cap screw must be replaced when removed and installed five times or anytime disk driver is replaced.

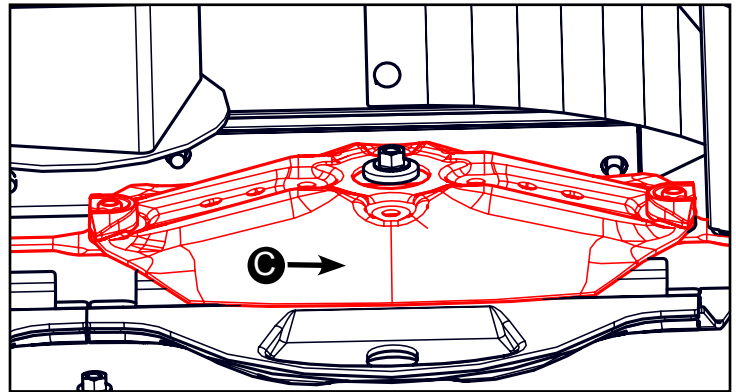

Remove hardened cap screw and Hillco washer (D). Hillco washer PN (1379751).

Remove disk driver (E).

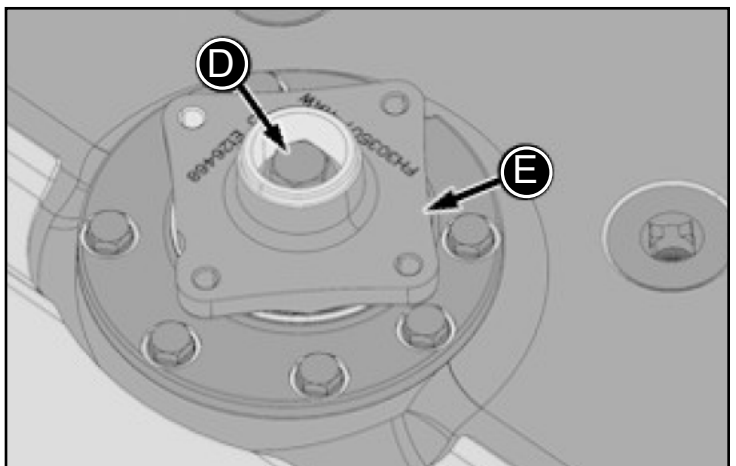

## End Drum Installation

**IMPORTANT:** It is critical that mating surfaces of bearing, driver, yoke, and driver retainer washer be free of dirt and crop before installing hardened cap screw. If these areas are not thoroughly cleaned, hardened cap screw can come loose and cause cutterbar failure.

**IMPORTANT:** If splines have been sheared, remove loose pieces of splines.

Inspect and clean all mating surfaces.

Align timing marks (A) and install driver (B) on pinion shaft.

Install hardened Hillco washer (PN 1379751).

**IMPORTANT:** To avoid machine damage, use new center cap screw treated with thread locking compound. Replace hardened cap screw with genuine John Deere part specified for this application.

12. Install cap screw and tighten according to specifications.

### Specification

Cap Screw (C)—Torque. . . . . 340 N·m (250 lb.-ft. + thread locking compound)

**Do Not use an impact on bolt on quill bearings! Use a block of wood to hold turtle when setting torque.**

**IMPORTANT:** Each disk must be installed 90° to adjacent disk. If disks are installed incorrectly, damage to machine will result.

**NOTE:** Disk life can be extended by moving disk to a location of opposite rotation. If procedure is done, knives must be interchanged for proper cutting direction. (See Install and Synchronize Disks and Install Knives in this section.)

**IMPORTANT:** It is critical that mating surfaces of U joint coupler-to-disk and disk-to-driver be free of dirt and crop material before installing. If these areas are not thoroughly cleaned, cap screws can come loose causing cutterbar damage.

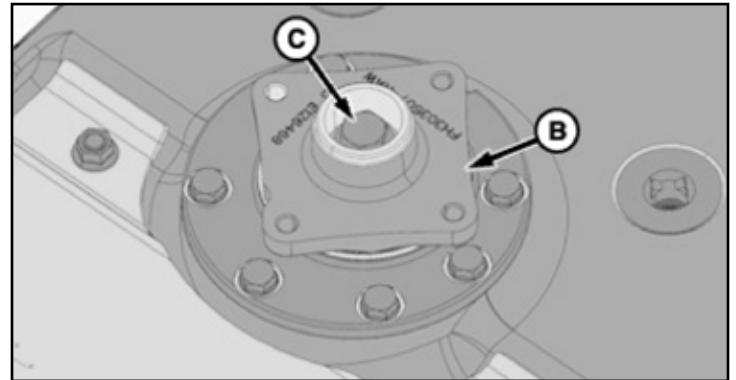
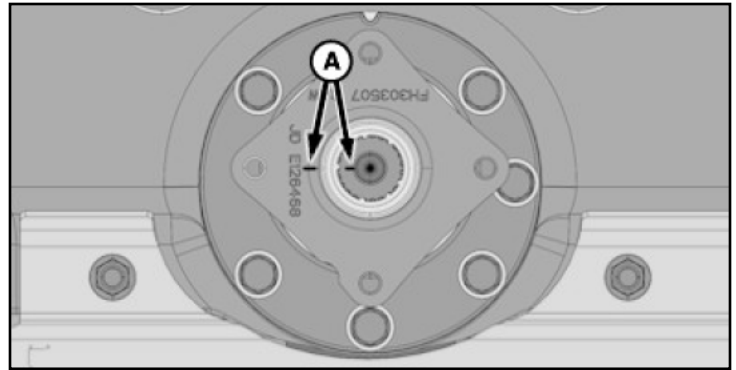

## IMPORTANT

The illustration shows a hand using a wrench to tighten a cap screw. Below it, a block of wood is shown with a wrench resting on it, representing the 'turtle' mentioned in the text.

**Quill Bearing Cap Screw Torque**  
Specification.....250 lb.-ft + thread locking compound

Refer to Operator's Manual for more information.

Install disk (A) in original position (90° to adjacent disk).

NOTE: Ears of inner yokes must be aligned.

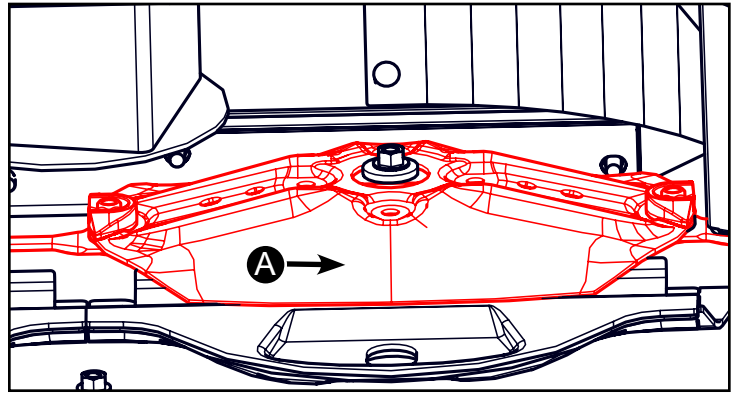

Install flanged drum (B) and insert driveshaft (C) from top down. Align splines so that the hole in the splined shaft aligns with the hole in the yoke (D).

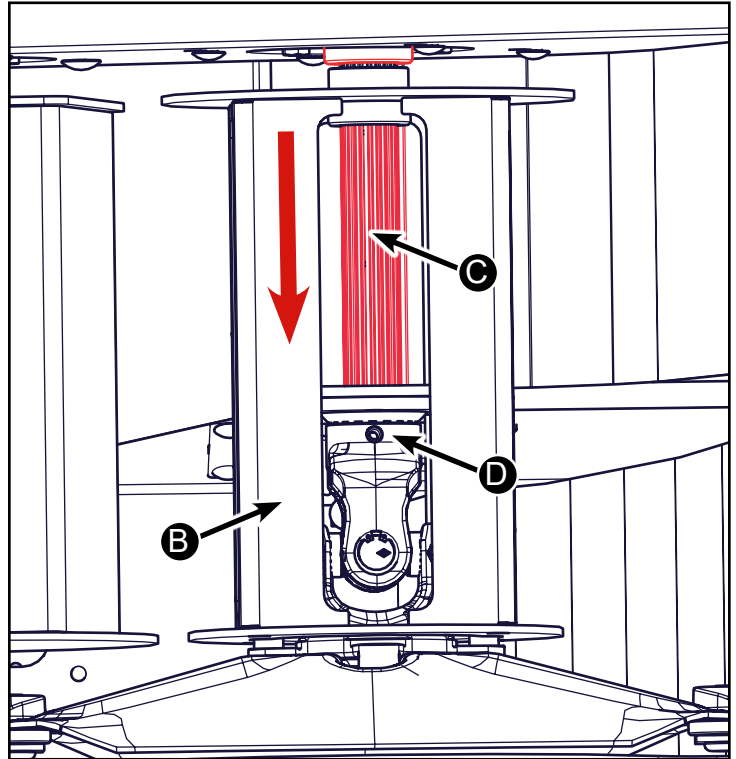

Fasten disk, converging drum with cap screws (E). Tighten cap screws to specification.

Specification

Cap Screws (E)—Torque . . . . . 150 N·m  
(110 lb.-ft.)

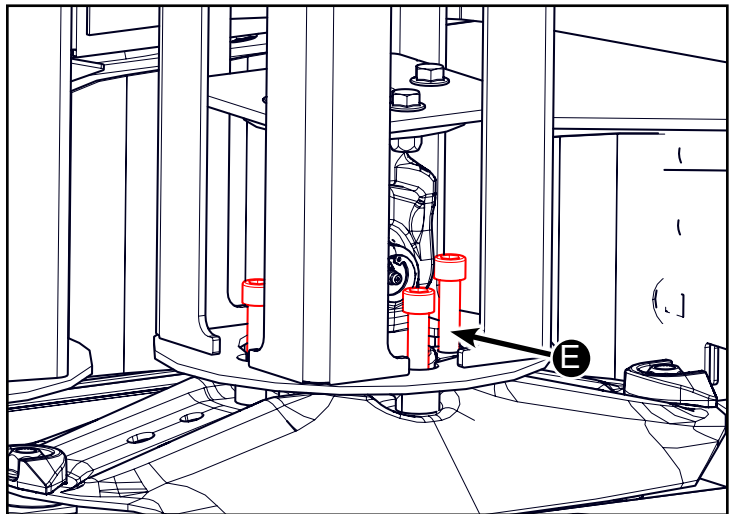

Reinstall the bolt (A) through the yoke and the splined shaft. Reinstall the bolt and nut (B) that was removed to access the cross bolt.

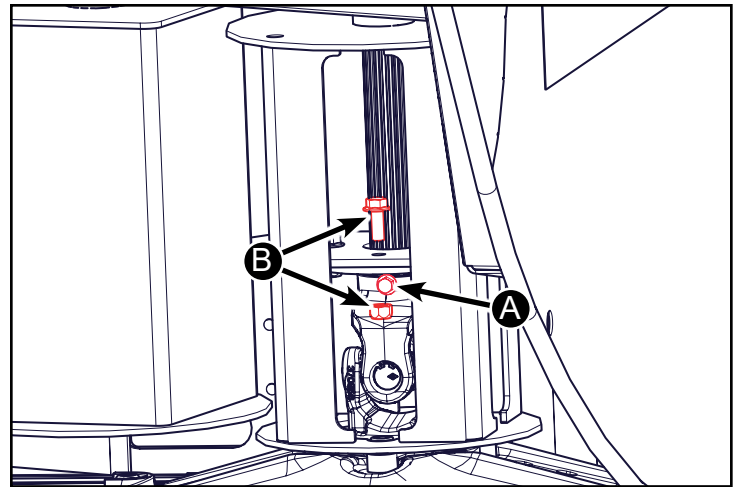

Install the 3 M10 Bolts (A) that hold the bearing flangettes to the split bearing mount plate.

Install the lock collar (D) locking the bearing to the sleeve. Lock collar opposite the rotation of the drum.

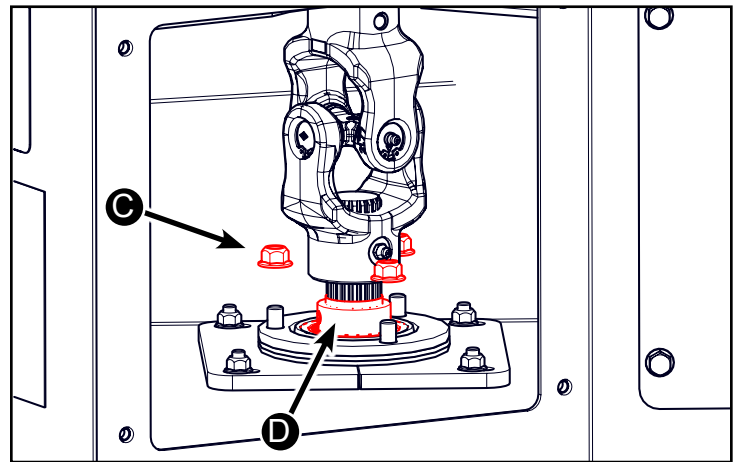

Align the drive shaft to the motor mount (B) and set the motor mount on the deck of the platform.

Install the 5 M12 bolts (C).

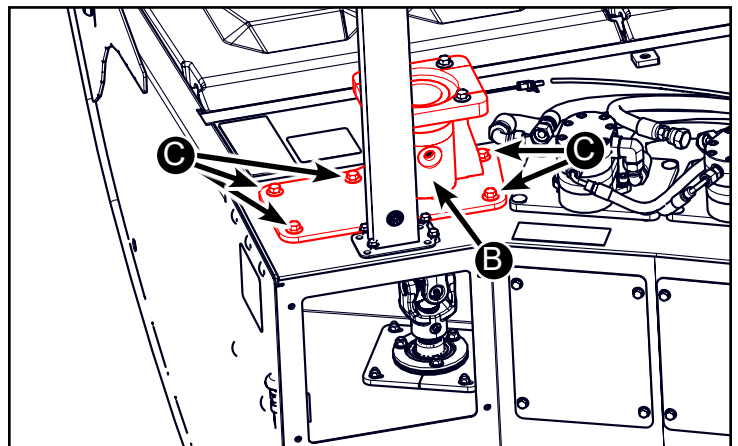

Install the service cover (D) using the (4) M8 bolts.

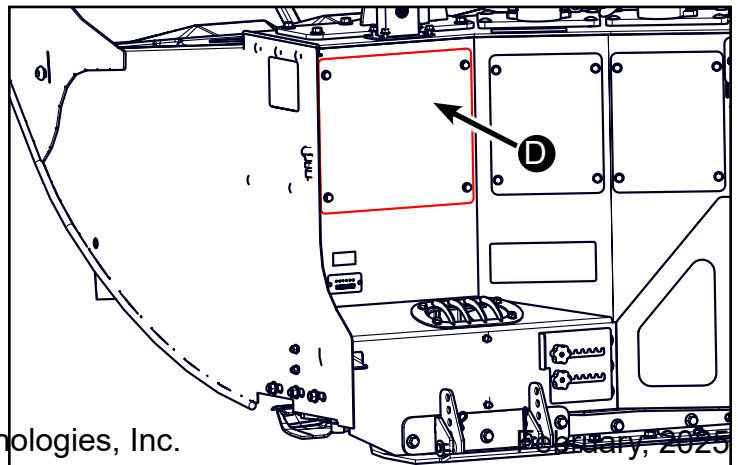

### Check Knives and Knife Bolts for wear

1. Park machine on level surface.
2. Raise platform, engage platform lockout lever, turn off engine, and remove key.
3. Check knife cutting edges (A):
  - Reverse knife if only one edge (forward cutting edge, relative to disk rotation) is worn to knife center (B).
  - Replace knife if both cutting edges are worn to center of knife.
4. Check knives for:
  - Cracks
  - Distortion
  - Excessive play at pivot bolt.

Replace knives immediately if any of these problems occur.

5. Remove knife. (See Remove Knives in this section.)

6. Check knife pivot hole for excessive wear. Replace if knife hole has become elongated (C) over initial hole diameter specification.

#### Specification

Knife Bolt Pivot Hole— Diameter ..... Elongated 2 mm (3/32 in.) over initial diameter

**CAUTION**

Prevent bodily injury or death. Do not work under or around raised platform without engaging lockout lever.

**CAUTION**

Knives have two sharp cutting edges and can cause serious injury. Wear gloves when handling knives.

**CAUTION**

Replace cracked, broken, or distorted knives immediately. Failure to do so may lead to loss of knife and bolt, or cause damage to cutterbar during operation.

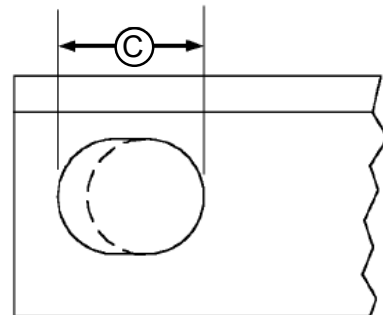
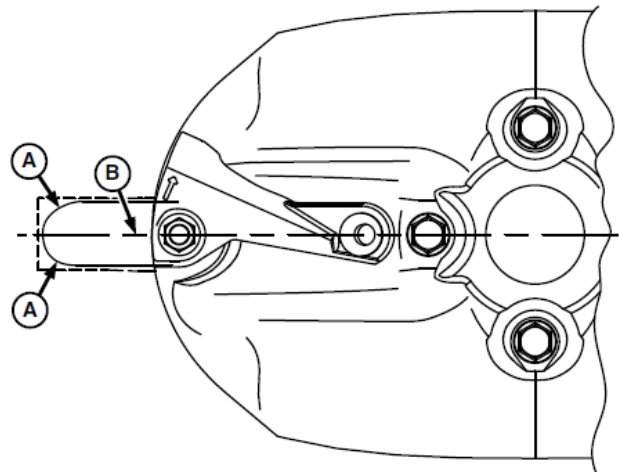

7. Inspect knife bolts for wear or damage.

8. Replace knife bolts if:

- Removed and installed five times or if thread locking compound is no longer effective.
- Head has worn flush with bearing surface of knife.
- Diameter of bolt neck has worn out of specification.

Specification

Knife Bolt

Neck—Diameter..... 3 mm (1/8 in.) under initial diameter

- Cracked. Examine bolt threads and head or shank interface (A).
- Damaged (B) due to interference. Correct interference problem.
- Bolts are visibly distorted.

9. Inspect knife nuts for wear or damage.

10. Replace nuts if:

- Worn height (A) is less than half total height (B).
- Removed and installed five times.
- Cracked.

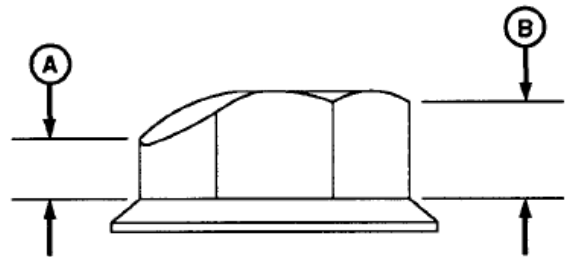
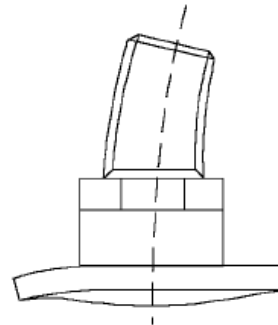
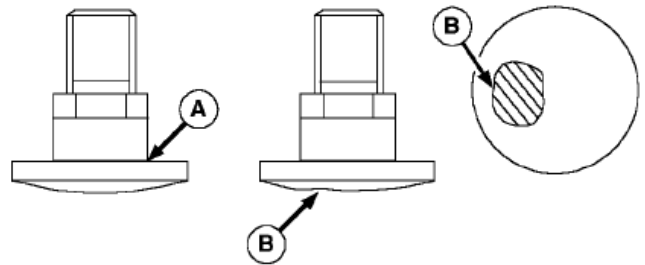
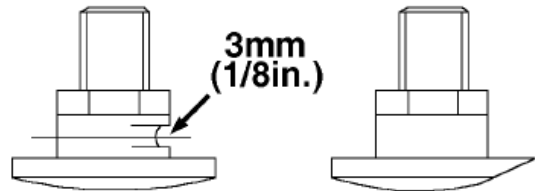
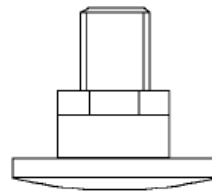

## Remove and Install Knives

1. Park machine on level surface.
2. Raise platform, engage platform lift lockout lever, turn off engine, and remove key.
3. To avoid serious injury, rotate both knives on all disks, so they are positioned UNDER disks.
4. Put a piece of wood between either end disk and outer sidesheet.
5. Clean area around lock nut (A).
6. Rotate disk so knife bolt is over hole (B). Remove lock nut and drop knife bolt through hole. If knife bolt is tight, move wear cap or crop accelerator toward center of disk using a hammer.
7. Inspect knives and hardware for wear or damage. (See Check Knives and Disks for Wear in this section.)
8. Clean knife bolt mounting area.

### CAUTION

Prevent bodily injury or death. Do not work under or around raised platform without engaging lockout lever.

### CAUTION

Knives have two sharp cutting edges and can cause serious injury. Wear gloves when handling knives.

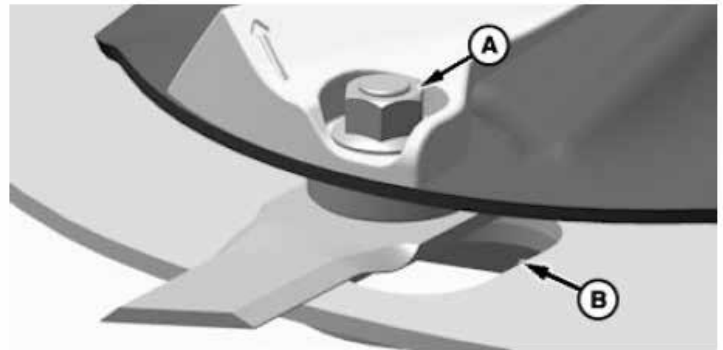

*Crop Accelerator*

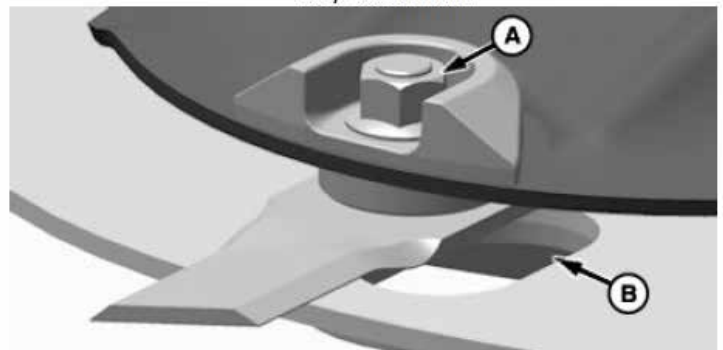

*Wear Cap*

**IMPORTANT:** Always use genuine John Deere knives. Replace each knife bolt and lock nut when it has been removed and installed five times.

**NOTE:** Knife bolt hex must align with hex in disk hole. Make sure that leading edge (C) (twist of knife is closest to ground) faces in same direction of disk rotation.

9. Install knife (D) as follows:

- Install knife with arrow in correct direction of rotation (F) and lowest side of twist in knife must be leading edge of knife. Knives can be installed with bevel up or down. With bevel down, knives do not dig up as many rocks and are less damaged by small rocks. With bevel up, knives pickup down crop better and cut slightly lower.

- **NEW KNIFE:** Install knife with bevel side of cutting edge facing toward ground.  
**REVERSING WORN KNIFE:** Install knife with bevel side of cutting edge facing upwards.

- Install knife bolt (A), spacer (E), and lock nut (B). Make sure that knife bolt is correctly seated in groove.

10. Tighten knife lock nut to specification.

Specification

Lock Nut (B)—Torque ..... 150 N·m  
(110 lb.-ft.)

11. Make sure that knife rotates freely on bolt.

**CAUTION**

If knife bolt (A) is installed incorrectly, lock nut (B) may not tighten sufficiently causing it to loosen during machine operation. Loss of bolt and knife during machine operation can cause personal injury or machine damage.

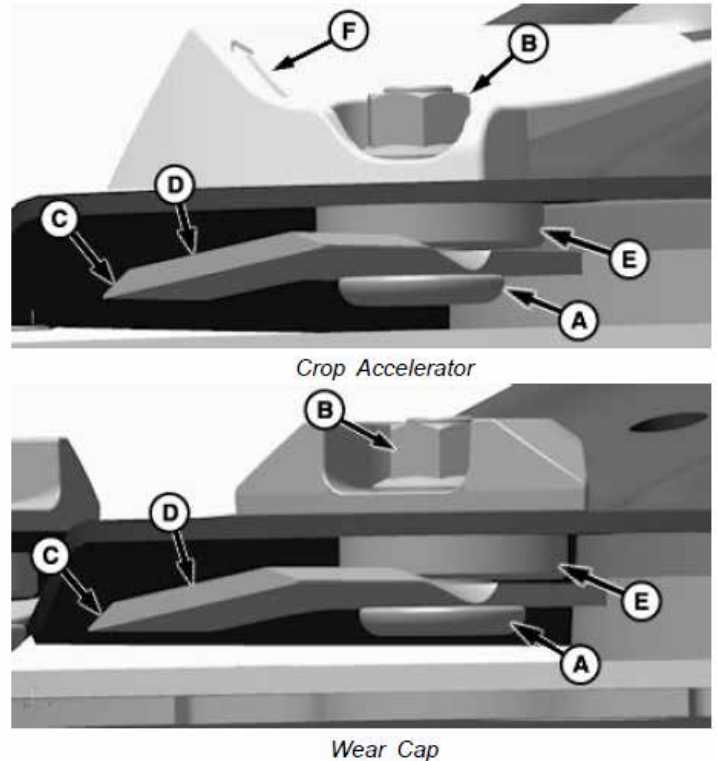

## Replace Wear Cap

1. Park machine on level surface.
2. Raise platform, engage platform lift lockout lever, turn off engine, and remove key.
3. Rotate disk so knife bolt is over hole (B).
4. Remove lock nut (A) and retain knife hardware.
5. Check disk, knife, special bolt, and knife lock nut before installing new wear cap. Replace as necessary.

(See Check Knives and Disks for Wear in this section.)

NOTE: Wear cap life can be extended by moving wear cap to a location of opposite rotation.

6. Install new wear cap (C).
7. Install knife. (See Remove and Install Knives in this section.)



### CAUTION

Prevent bodily injury or death. Do not work under or around raised platform without engaging lockout lever.



### CAUTION

Knives have two sharp cutting edges and can cause serious injury. Wear gloves when handling knives.

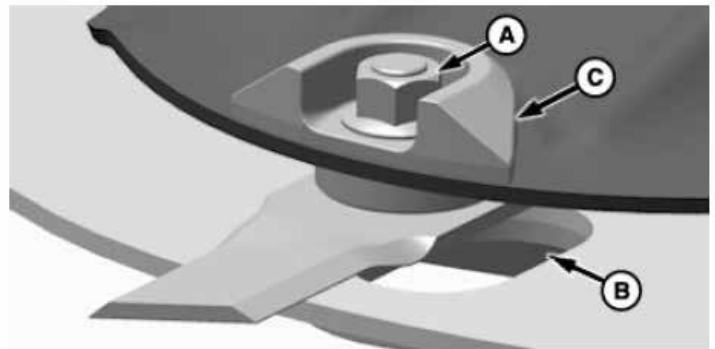

Wear Cap

## Replace Crop Accelerator

1. Park machine on level surface.
2. Raise platform, engage platform lift lockout lever, turn off engine, and remove key.
3. Remove knife. (See Remove and Install Knives in this section.)
4. If crop accelerator is located on intermediate disks, see Remove Disks in this section. If crop accelerator is located on end disk driver, see Replace Left-Hand End Disk Driver or Replace Right-Hand End Disk Driver in this section.

### CAUTION

Prevent bodily injury or death. Do not work under or around raised platform without engaging lockout lever.

### CAUTION

Knives have two sharp cutting edges and can cause serious injury. Wear gloves when handling knives.

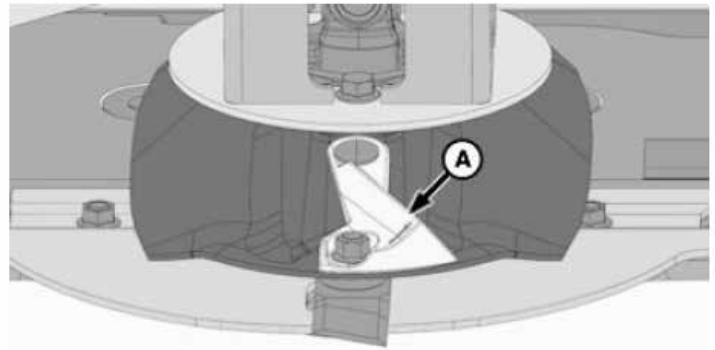

*End Disk Driver - Crop Accelerator*

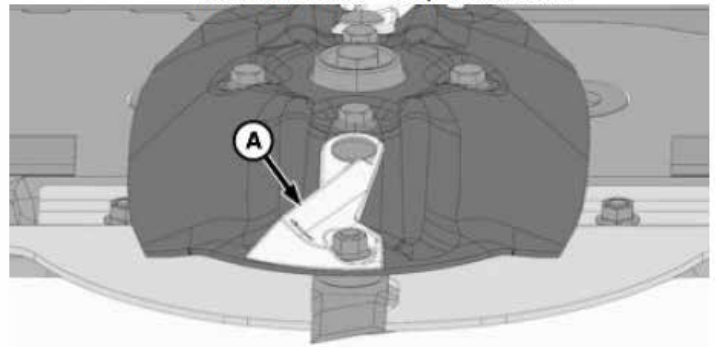

*Intermediate Disk - Crop Accelerator*

5. Remove crop accelerator (A).
6. Inspect knife bolt (B), knife (C), spacer (D), lock nuts (E and G), and round-head bolt (F) before installing new crop accelerator. Replace as necessary. (See Check Knives and Remove Knives in this section.)
7. Install new crop accelerator.
8. Install disk.
9. Install knife and hardware. (See Remove and Install Knives in this section.)

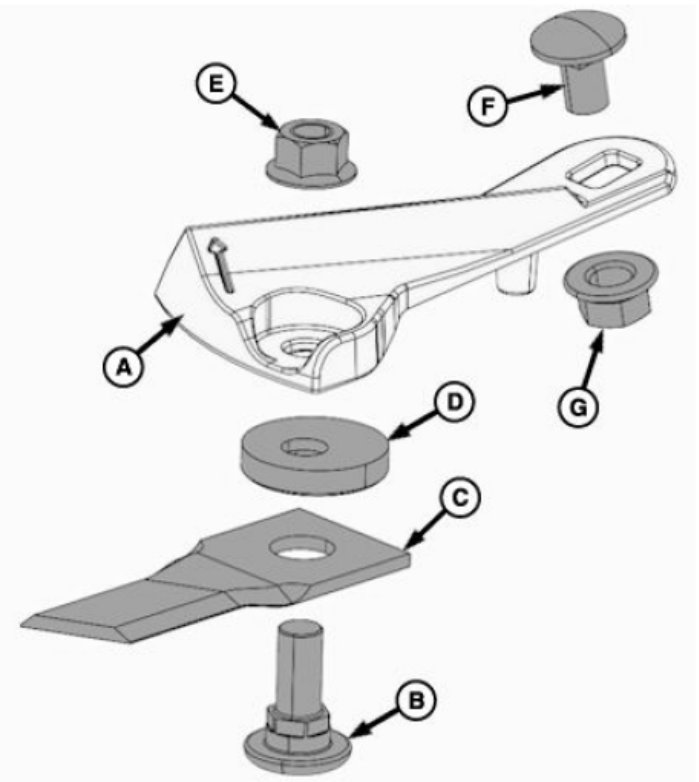

## Install and Synchronize Disks

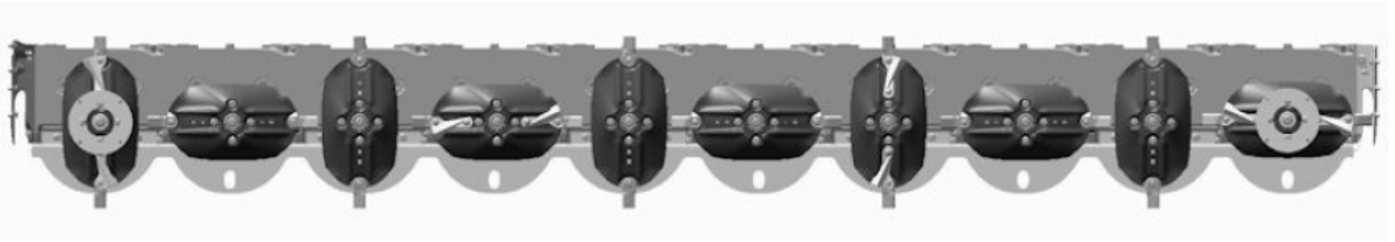

1. Park machine on level surface.
2. Raise platform, engage platform lift lockout lever, turn off engine, and remove key.

**IMPORTANT:** Each disk must be installed 90° to adjacent disk. If disks are installed incorrectly, damage to machine will result. If disk is not 90° to adjacent disks with timing marks aligned, check pinion gear timing. Pinion gear can be off by one or more teeth. (See Cutterbar Quill and Pinion Gear Timing Detail in this section.)

**⚠ CAUTION**

Prevent bodily injury or death. Do not work under or around raised platform without engaging lockout lever.

Disk-to-driver cap screws are treated with thread locking compound and can be used up to five times. Replace with John Deere cap screw specified for this application.

**⚠ CAUTION**

Knives have two sharp cutting edges and can cause serious injury. Wear gloves when handling knives.

**NOTE:** Disk life can be extended by moving disk to a location of opposite rotation. If procedure is done, knives must be interchanged for proper cutting direction. (See Install Knives in this section.)

3. Clean mounting surface of foreign material. Install disk in its original position.
4. If equipped with rotary strippers (optional). (See Remove and Install Rotary Strippers in this section.)
5. Fasten with four locking cap screws. Tighten cap screws to specification.

If installing left-hand end disk, see Replace Left-Hand End Disk Driver in this section. If installing right-hand end disk, see Replace Right-Hand End Disk Driver in this section.

### Specification

Disk-to-Driver Cap	
Screws—Torque .....	150 N·m (110 lb.-ft.)

Replace cap screws after removing and installing five times.

6. Remove wood block.
7. Rotate disks several times by hand to check synchronization. Make sure that there is no interference between knives.
8. Lower front doors.

## Electrical System and Components

Electrical system power source is the John Deere power strip (A) on the RH floor of the operators station. It plugs into a standard slot and uses both the Red (power live) and Orange (key power) posts in the power strip along with the ground wire.

When the key is turned on the power comes on the orange wire and triggers the relay for power for both the screen and the microprocessor. In addition to the power and ground that they share they also have CAN wires to communicate on.

The screen (B) is mounted beside the John Deere control screen. The operators section explains how to navigate the monitor screen. Below the screen is the drum speed encoder dial (C).

The controller (D) is located on the platform behind the electrical connectors (E). When properly powered there is a green light on the face of the controller.

To access the controller remove the 4 bolts.

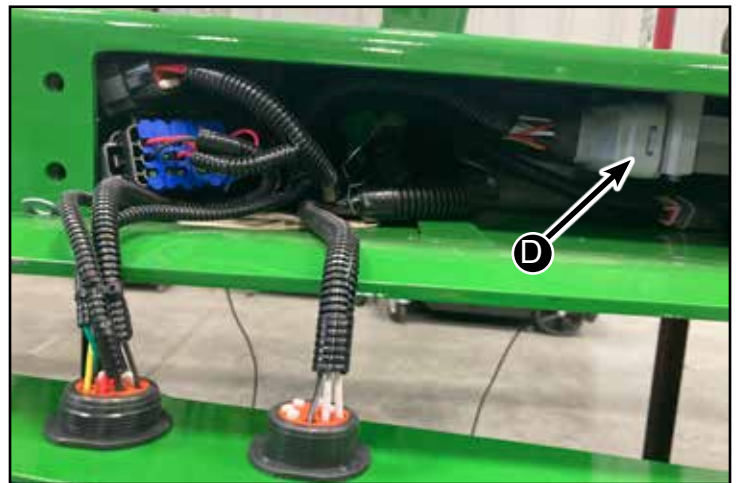
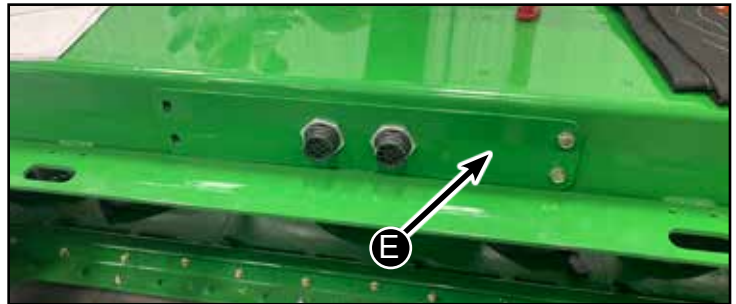
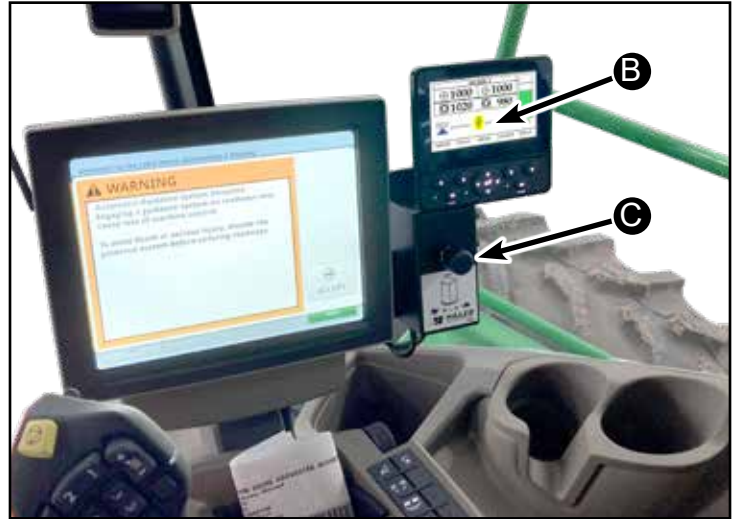

# Electrical Schematics and Harnesses

## Primary Wiring Harness (1375671)

Harness is located inside of platform.

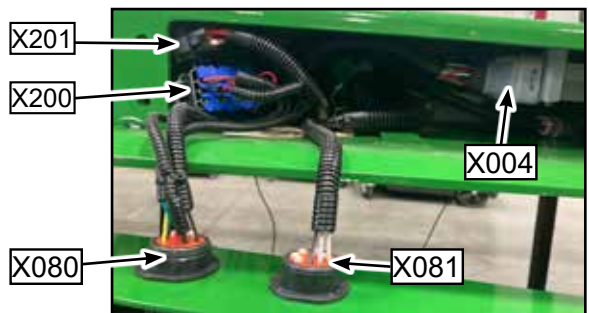
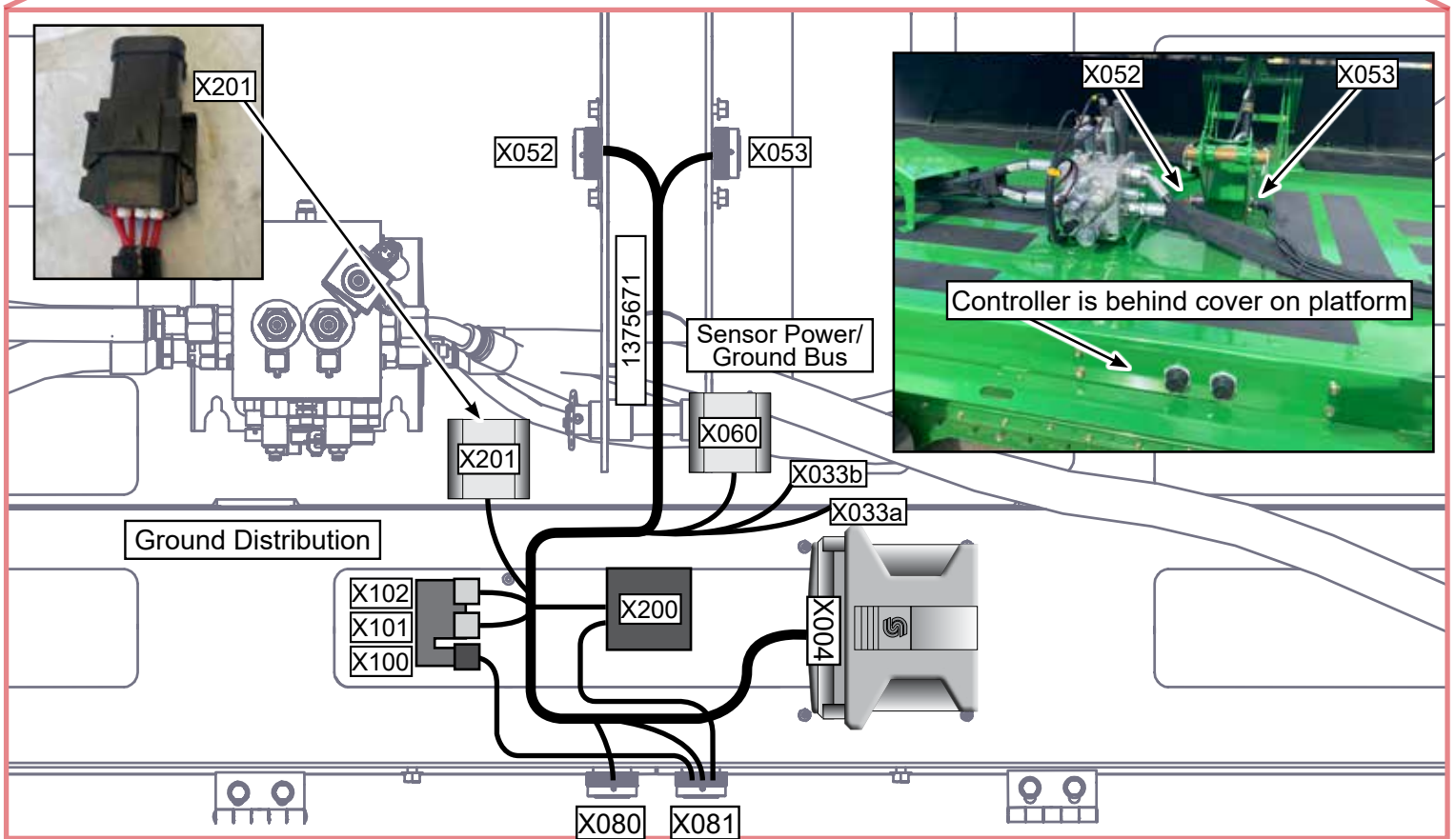
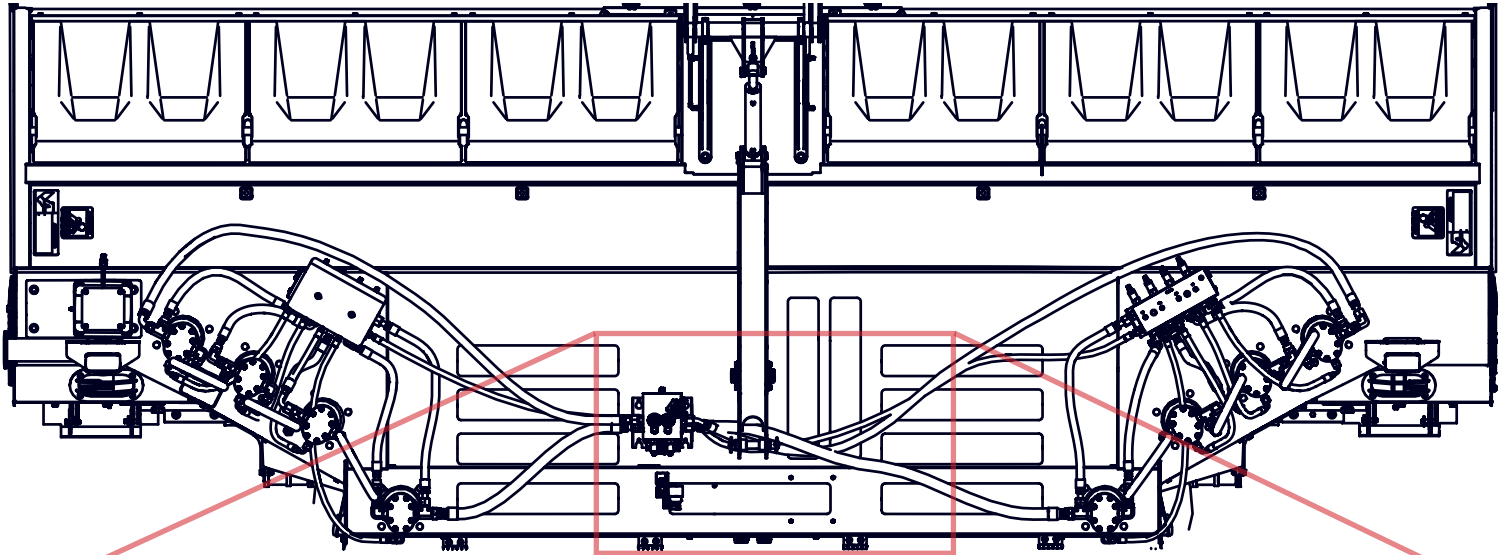



REV.	DESCRIPTION	DATE	BY	WELD SYMBOLS	Part #	1375671	C
A	Released for Production	01/05/2022	SJM	01/05/2022	OT ASM - HARNESS HCU PRIMARY		
B	Shortened legs 2 and 3 and replaced X35 & X01 w/ X081 & X081	02/02/2022	SJM	02/02/2022	Description SEE BELOW		
C	Corrected part numbers for X100 housing and terminal & X200 pin assignments	04/11/2022	SJM	04/11/2022	Material SEE BELOW		

**LIGHTS**

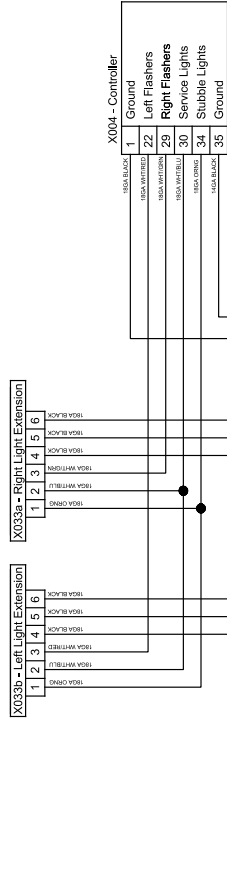

1	100A BLACK
2	100A BLACK
3	100A BLACK
4	100A BLACK
5	100A BLACK
6	100A BLACK
7	100A BLACK
8	100A BLACK
9	100A BLACK
10	100A BLACK
11	100A BLACK
12	100A BLACK

1	100A BLACK
2	100A BLACK
3	100A BLACK
4	100A BLACK
5	100A BLACK
6	100A BLACK
7	100A BLACK
8	100A BLACK
9	100A BLACK
10	100A BLACK
11	100A BLACK
12	100A BLACK

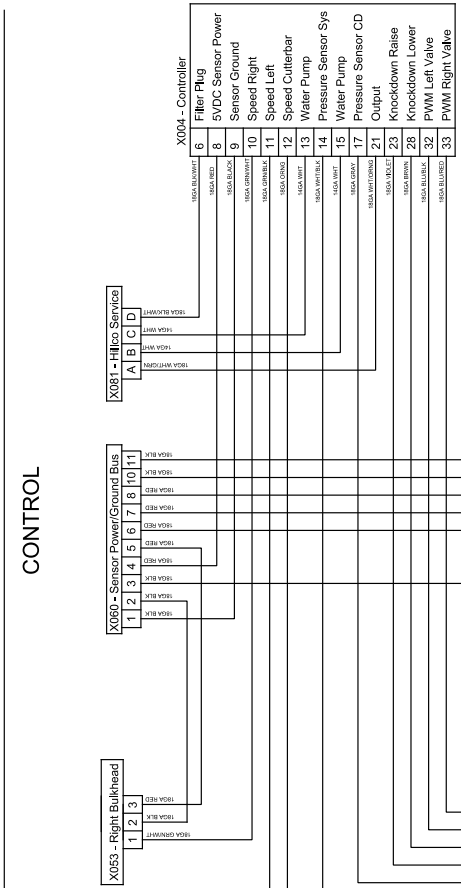

**CAN BUS**

WIRES SHALL FORM A TWISTED PAIR PER SAE J1939-15  
 CABLE TWISTING MUST BEGIN AT LEAST 2 INCHES FROM THE CONNECTOR TERMINALS  
 CABLE TWIST RATE SHALL BE A MINIMUM OF 1 TWIST PER INCH



1	200A YELLOW
2	200A GREEN
3	CAN High
4	CAN Low

# Manifold Harness & Speed Sensor Harness (1375691 & 1375701)

Harness is located on top of platform by middle manifold.

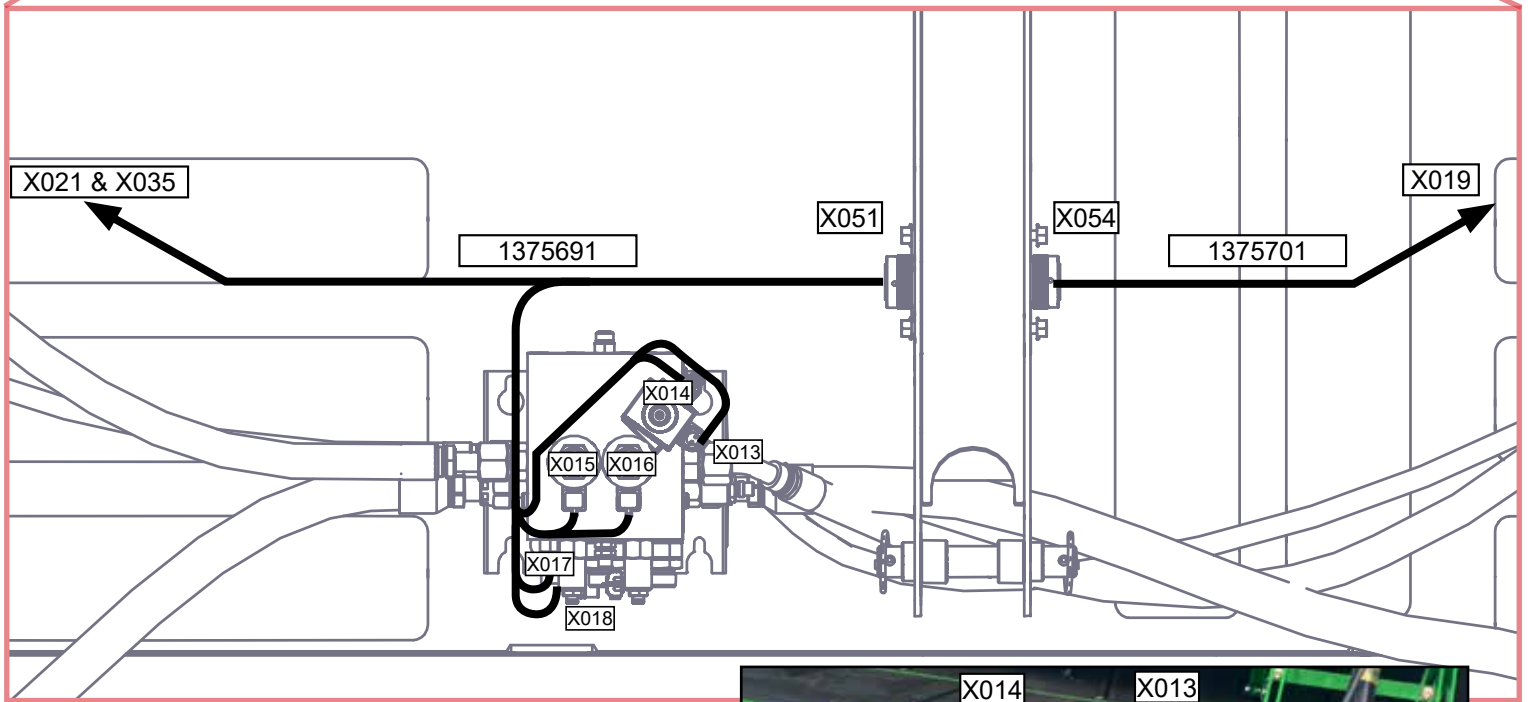
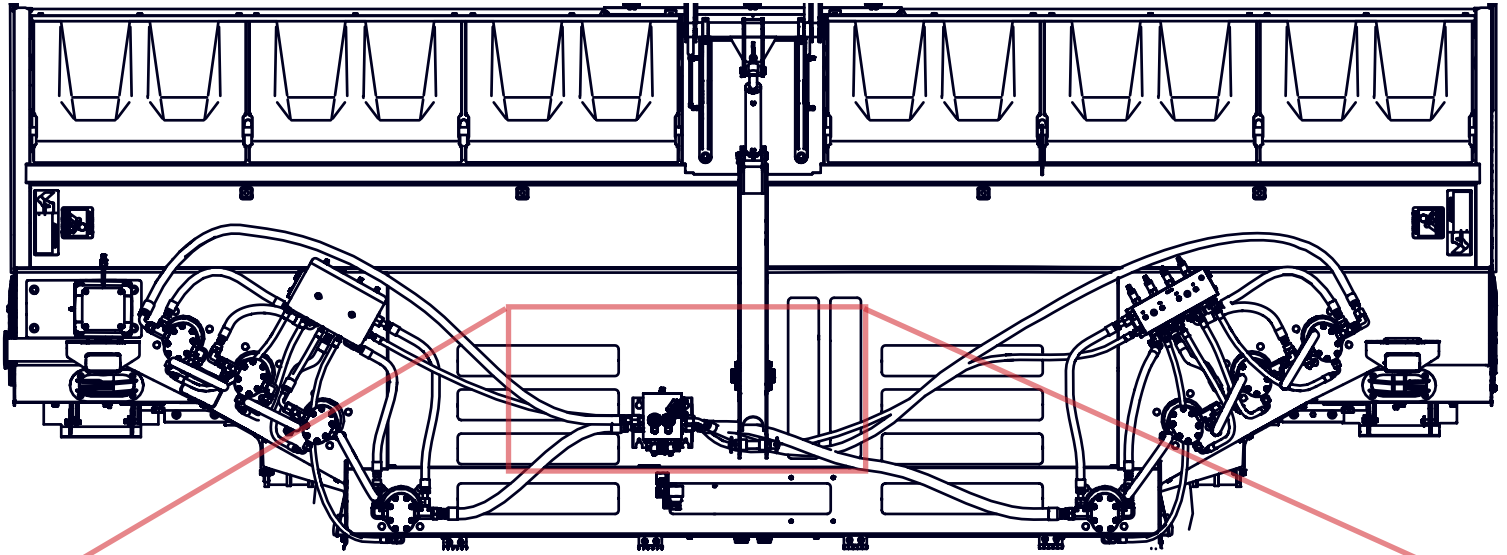

D-220415CMA01B

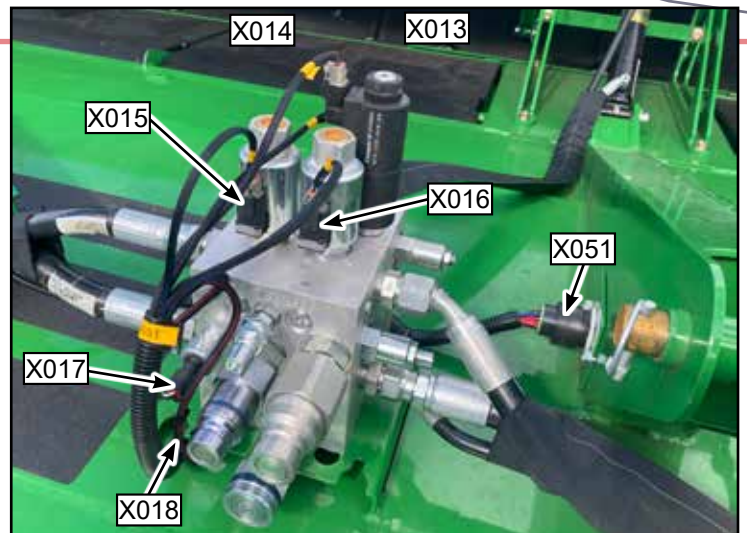

REV.	DESCRIPTION	DATE	BY	WELD SYMBOLS	HILLCO	PART #	1375691	B
A	Released for Production	01/10/2022	SJV	2X ± 0.005 1/16 ± 0.005 Set #1	OT ASM, HARNESS, HCU LEFT CONTROL			
B	Revised W22 to W21 to avoid confusion	02/15/2022	SJV	xxx ± 0.005 xxxx ± 0.005 UNIT OF MEASURE: INCHES Weld according to HILLCO Welding Standards Doc. #D-062141000a	DESCRIPTION SEE BELOW Material S/WV Designed S/WV Sheet 1 of 2 N/A			

CONNECTOR	DESCRIPTION	TYPE	HOUSING PART #	TERMINAL PART #	ACCESSORIES PART #
X051	LEFT BULKHEAD	DEUTSCH	HDP26-16-21SN	0462-201-20141	HD30-18BT-BK, 0413-204-2005
X013	KDB RAISE COIL	DEUTSCH	DT06-2S	0462-201-16141	W2S
X014	KDB LOWER COIL	DEUTSCH	DT06-2S	0462-201-16141	W2S
X015	PWM RIGHT COIL	DEUTSCH	DT06-2S	0462-201-16141	W2S
X016	PWM LEFT COIL	DEUTSCH	DT06-2S	0462-201-16141	W2S
X017	WORK PRESSURE SENSOR	APTIV	12065287	12048074	
X018	CD PRESSURE SENSOR	AMPSEAL 16	776426-1	1924464-1	
X021	LEFT MOTOR SPEED SENSOR	DEUTSCH	DTM06-3S	0462-201-20141	WM1-3S
X035	CUTTERBAR SPEED SENSOR	APTIV	12010973	12089040	

BRANCH	LENGTH
1	6 INCHES
2	24 INCHES
3	8 INCHES
4	8 INCHES
5	8 INCHES
6	8 INCHES
7	8 INCHES
8	8 INCHES
9	78 INCHES
10	6 INCHES
11	36 INCHES

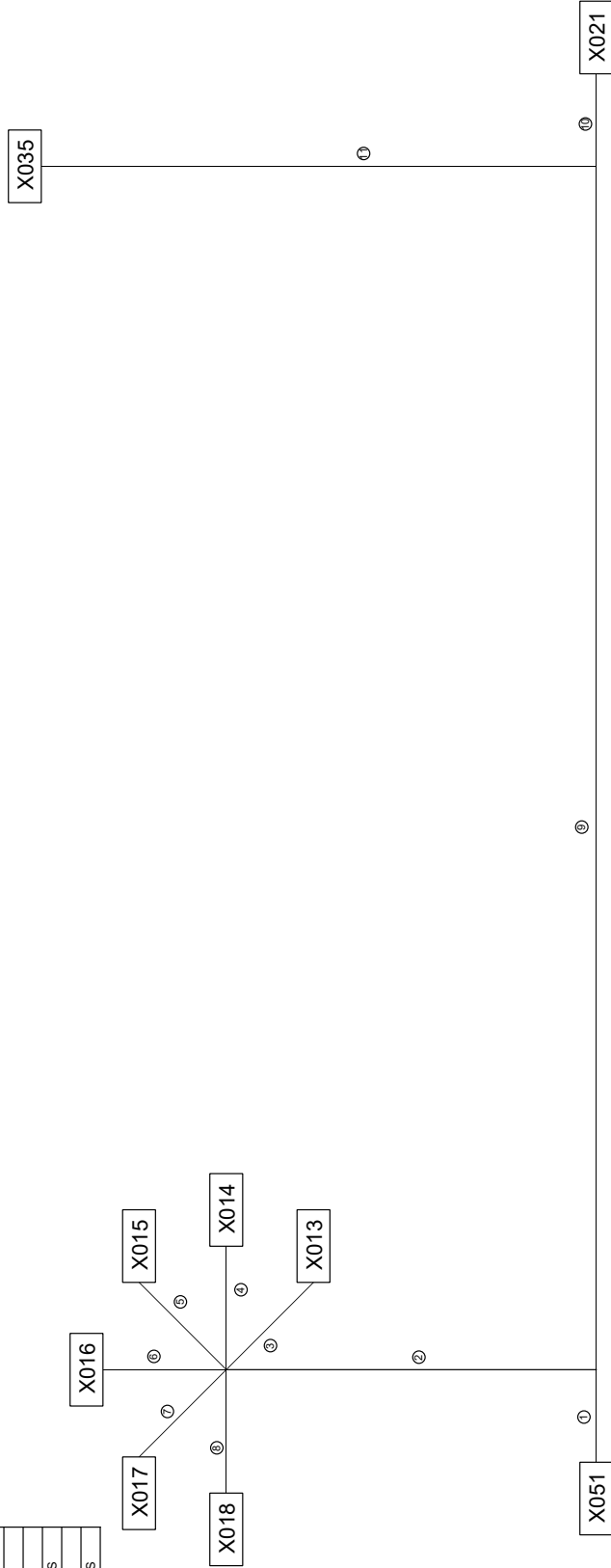

REV.	DESCRIPTION	DATE	BY	MISC. WORK CENTER	HILCO	Part #	1375691	B
A	Released for Production	01/10/2022	SJM	TOOL DIES				
B	Revised A02 to A03 to avoid confusion	02/15/2022	SJM	Regular ± 0.1 As ± 0.05	OT ASM. HARNESS, HCU LEFT CONTROL			
				As ± 0.03 As ± 0.05	SEE BELOW			
				As ± 0.05	No. Terminals			
				As ± 0.05	Design			
				As ± 0.05	Sheet 2 of 2			
				As ± 0.05	Unit of Measure			
				As ± 0.05	Drum			
				As ± 0.05	Material			
				As ± 0.05	See Below			
				As ± 0.05	Treatment			
				As ± 0.05	None			
				As ± 0.05	All information contained in this document is confidential and proprietary. Do not distribute or reproduce without written permission. This document is for internal use only, except where indicated otherwise. No part of this document may be reproduced without written permission. See the terms and conditions of the license for more information.			

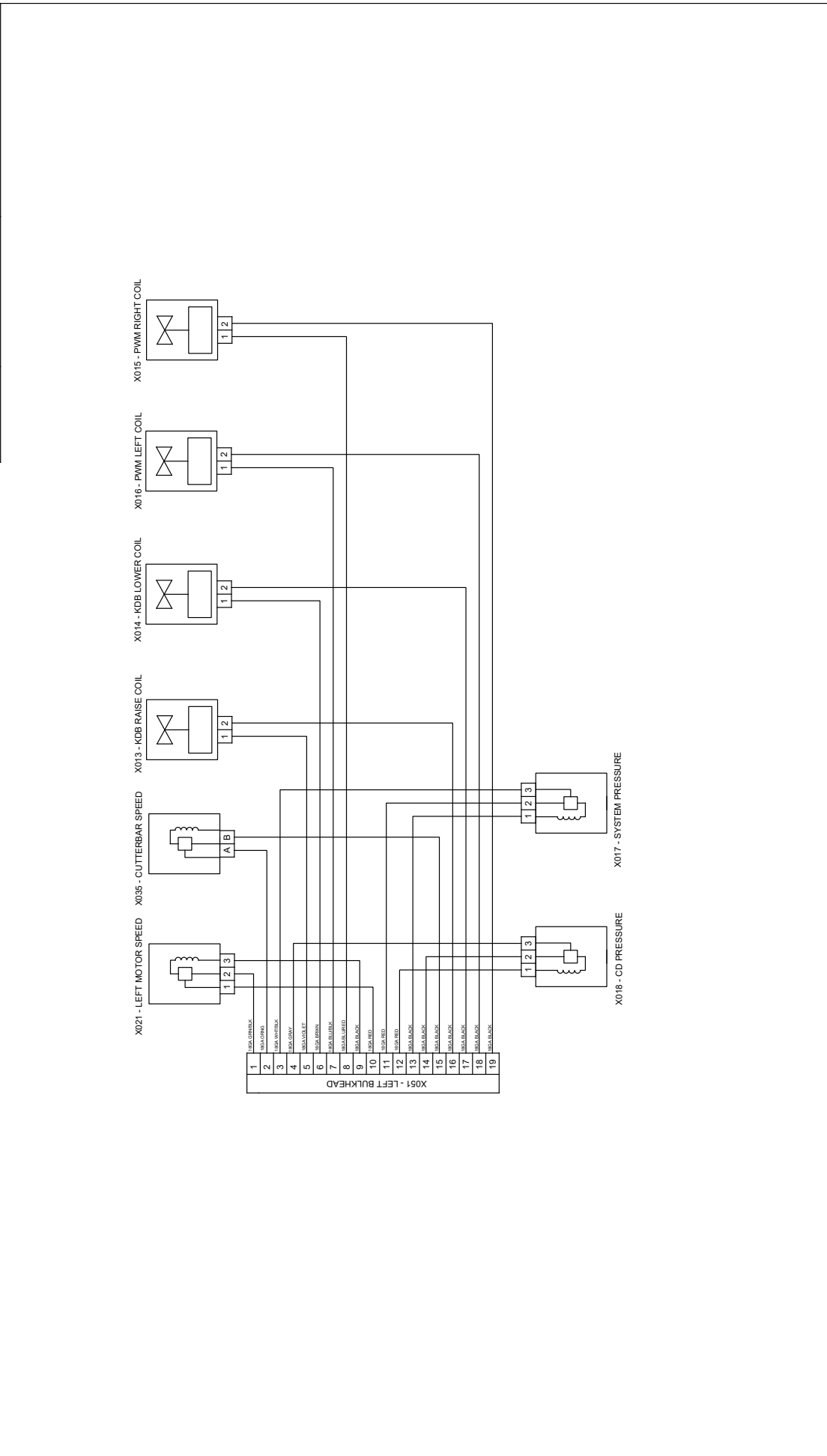



**Light harness (1375681)**  
Installed inside of platform

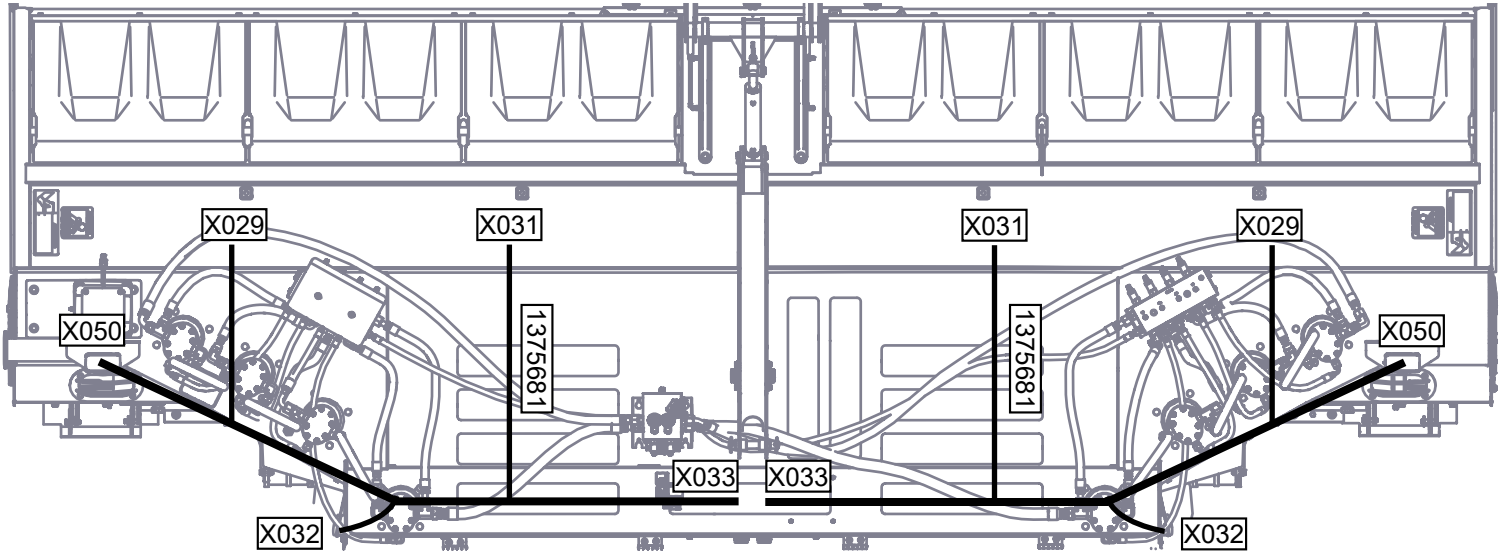

REV. #	DESCRIPTION	DATE	BY	DESIGN	DATE	BY	TEST
A	Released for Production	07/05/2022	SJM	05/05/2022	SJM		
B	Change X050 From Deutsch to Aptiv to match Bere Part						

REV. #	DESCRIPTION	DATE	BY	DESIGN	DATE	BY	TEST
A	Released for Production	07/05/2022	SJM	05/05/2022	SJM		
B	Change X050 From Deutsch to Aptiv to match Bere Part						

REV. #	DESCRIPTION	DATE	BY	DESIGN	DATE	BY	TEST
A	Released for Production	07/05/2022	SJM	05/05/2022	SJM		
B	Change X050 From Deutsch to Aptiv to match Bere Part						

REV. #	DESCRIPTION	DATE	BY	DESIGN	DATE	BY	TEST
A	Released for Production	07/05/2022	SJM	05/05/2022	SJM		
B	Change X050 From Deutsch to Aptiv to match Bere Part						

REV. #	DESCRIPTION	DATE	BY	DESIGN	DATE	BY	TEST
A	Released for Production	07/05/2022	SJM	05/05/2022	SJM		
B	Change X050 From Deutsch to Aptiv to match Bere Part						

CONNECTOR	DESCRIPTION	TYPE	HOUSING PART #	TERMINAL PART #	ACCESSORIES PART #
X033	LIGHT EXTENSION	DEUTSCH	DT04-6P	0460-202-16141	W6P, 114017
X031	SERVICE LIGHT #1	DEUTSCH	DTM04-2P	0460-202-20141	WM-2P
X029	SERVICE LIGHT #2	DEUTSCH	DTM04-2P	0460-202-20141	WM-2P
X032	STUBBLE LIGHT	DEUTSCH	DTM04-2P	0460-202-20141	WM-2P
X050	FLASHER	APTIV	12015792	12089188-L	15324982

BRANCH	LENGTH
1	6 INCHES
2	24 INCHES
3	32 INCHES
4	24 INCHES
5	4 INCHES
6	6 INCHES
7	55 INCHES

1	BLACK
2	BLACK
3	BLACK
4	BLACK
5	BLACK
6	BLACK

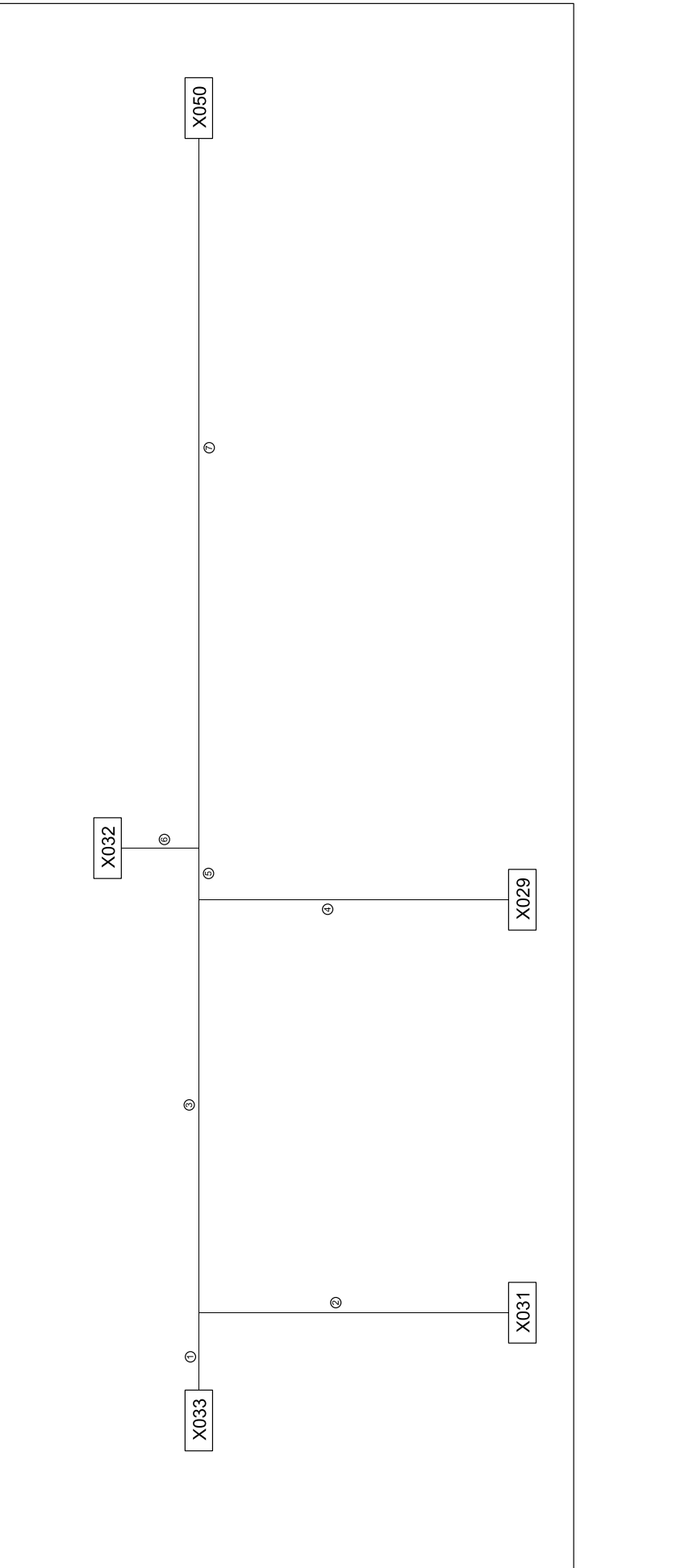
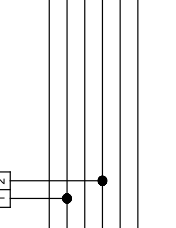

HCU Harness (1375992)  
Cab Harness

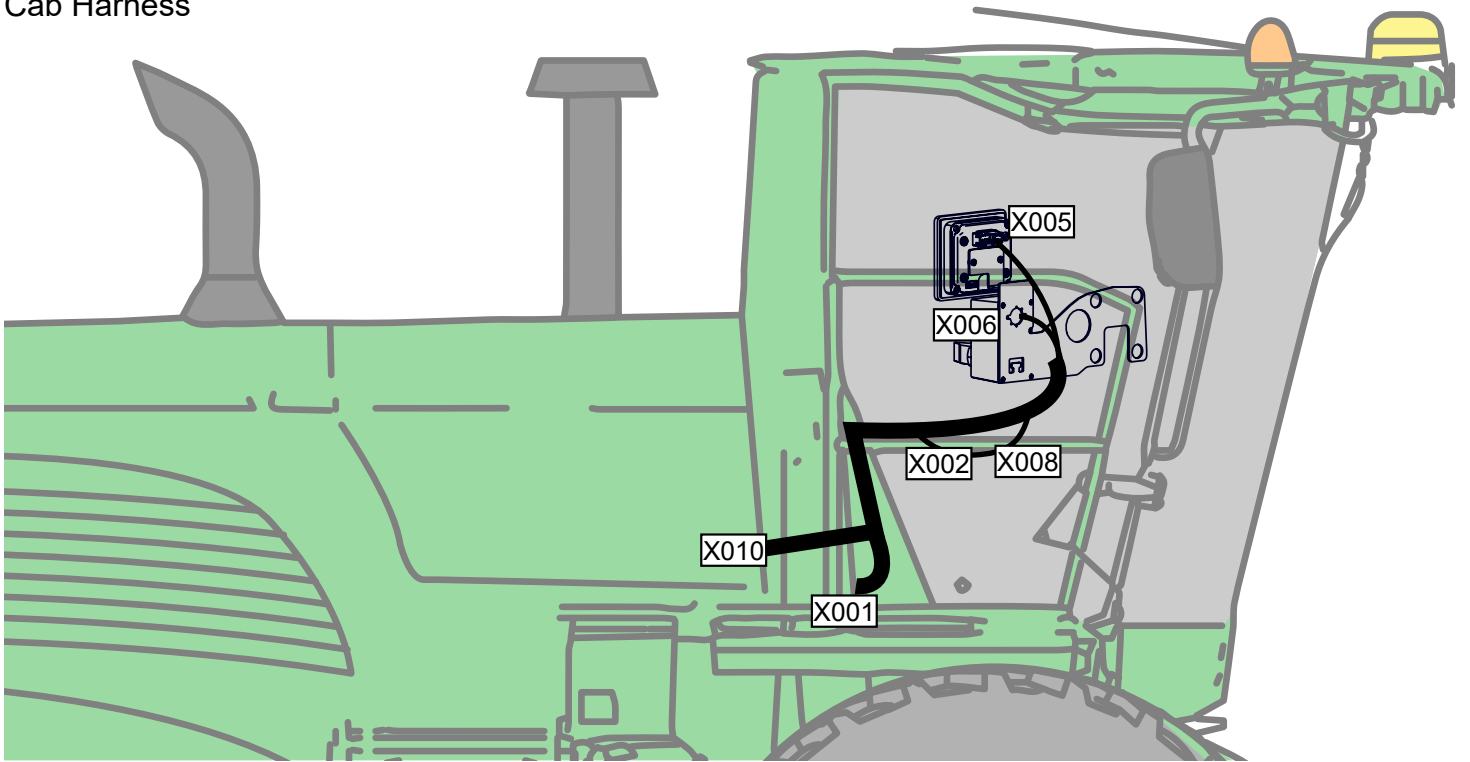



# HCU CAN Extension Harness (1376002)

## CAN Harness

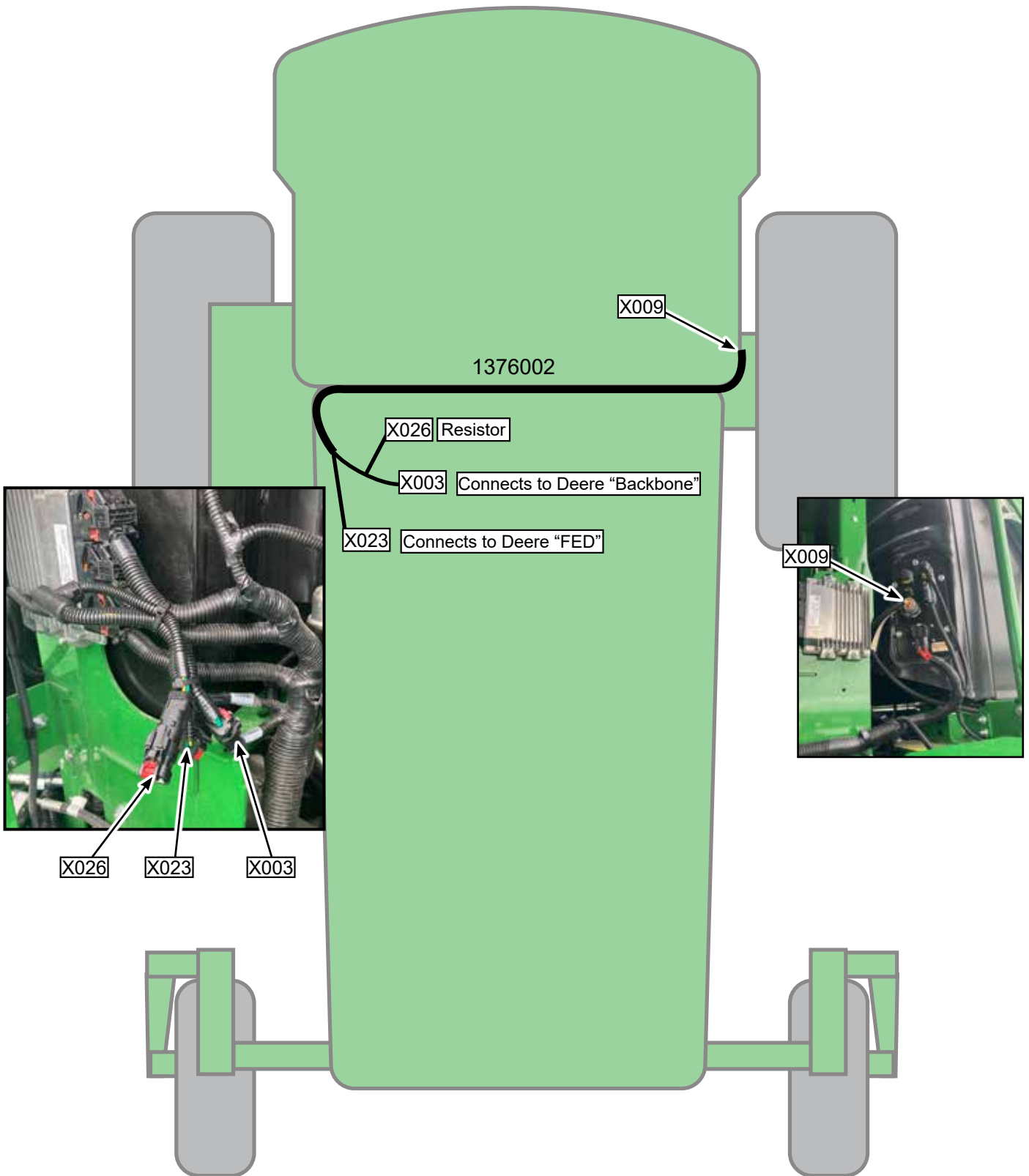

REV.	DESCRIPTION	DATE	BY	DESCRIPTION	Part #	1376002	B
A	Released for Production	04/12/2022	SJM	OT ASM, HARNESS, HCU CAN EXTENSION			
B	Lengthened branch 3 1/2"	04/26/2022	SJM	Material: SEE BELOW			

REV.	DESCRIPTION	DATE	BY	DESCRIPTION	Part #	1376002	B
A	Released for Production	04/12/2022	SJM	OT ASM, HARNESS, HCU CAN EXTENSION			
B	Lengthened branch 3 1/2"	04/26/2022	SJM	Material: SEE BELOW			

REV.	DESCRIPTION	DATE	BY	DESCRIPTION	Part #	1376002	B
A	Released for Production	04/12/2022	SJM	OT ASM, HARNESS, HCU CAN EXTENSION			
B	Lengthened branch 3 1/2"	04/26/2022	SJM	Material: SEE BELOW			

REV.	DESCRIPTION	DATE	BY	DESCRIPTION	Part #	1376002	B
A	Released for Production	04/12/2022	SJM	OT ASM, HARNESS, HCU CAN EXTENSION			
B	Lengthened branch 3 1/2"	04/26/2022	SJM	Material: SEE BELOW			

CONNECTOR	DESCRIPTION	TYPE	HOUSING PART #	TERMINAL PART #	ACCESSORIES PART #
X003	CAB CAN	AMPSEAL 16	776427-1	1924464-1	
X009	CAB BULKHEAD	DEUTSCH	HD16-3-96S	0462-201-16141	114017
X023	PLATFORM CAN	AMPSEAL 16	776427-1	1924464-1	
X026	CAB CAN TEE	AMPSEAL 16	776428-1	1924463-1	

BRANCH	LENGTH
1	8 INCHES
2	8 INCHES
3	74 INCHES
4	8 INCHES

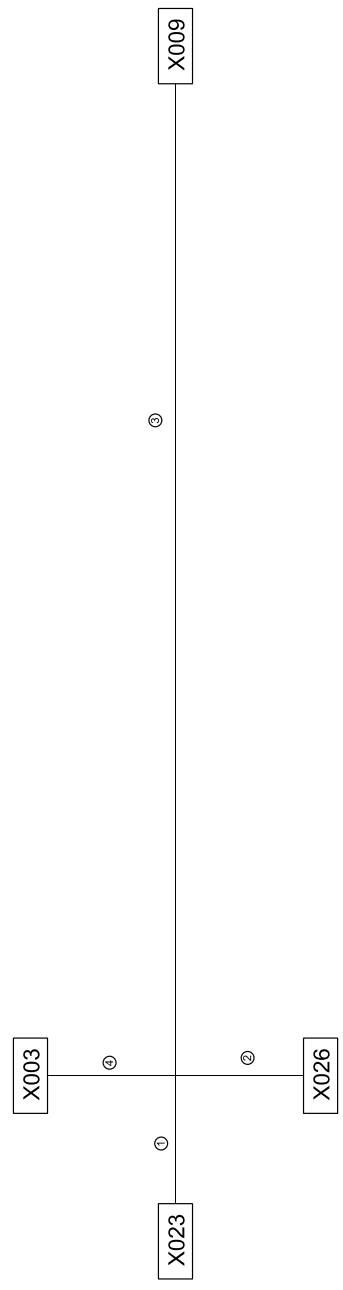
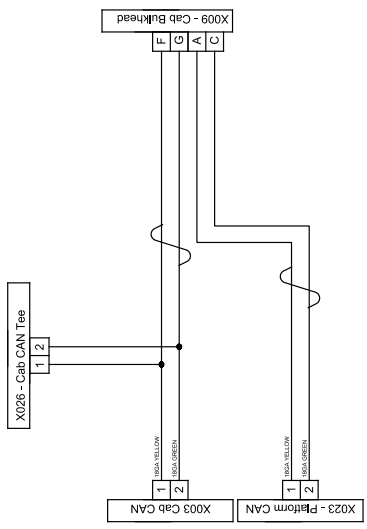



REV.	DESCRIPTION	DATE	BY	DESCRIPTION	DATE	BY
A	Released for Production	02/02/2022	S.W			
B	Corrected WDS part numbers & added wire between pins 6&7	02/28/2022	S.W			

HILLCO TECHNOLOGIES, INC.		Part # 1376241		B	
Description		OT ASM, HAR, DEERE SERVICE		Treatment	
Material		SEE BELOW		NONE	
Designed		SJM / Drawn		SJM	
Sheet 1 of 1		Vt		N/A	
UNIT OF MEASURE: INCHES		Weld according to HILLCO Welding Standards Doc ID-802540J00A			

WELDING TOLERANCES  
 1/16" ± 0.005  
 1/8" ± 0.005  
 1/4" ± 0.005  
 3/8" ± 0.005  
 1/2" ± 0.005  
 3/4" ± 0.005  
 1" ± 0.005  
 All information contained in this document is confidential and proprietary. Do not distribute or reproduce without written permission. If you have any questions, please contact your account manager. If you are not an authorized user, receipt of this information is unauthorized and its use, disclosure, or distribution for any purpose other than that for which it may be issued, is prohibited.

CONNECTOR TABLE			
CONNECTOR	DESCRIPTION	TYPE	HOUSING PART #
X036	DEERE MPC	DEUTSCH	HDP26-24-9TSE-P064
X082	DEERE SERVICE	DEUTSCH	HD16-9-1939S
			0462-201-16141, 0462-203-12141, 0462-203-08141
			114017
			ACCESSORIES PART #
			HD30-18BT-BK, 114017

LENGTH TABLE	
BRANCH	LENGTH
1	70 INCHES

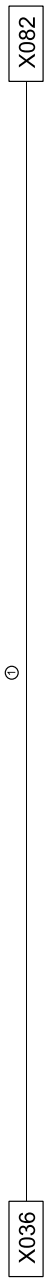
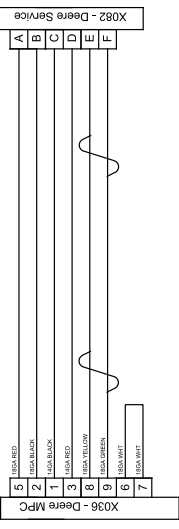



# Hydraulic Components & Schematic

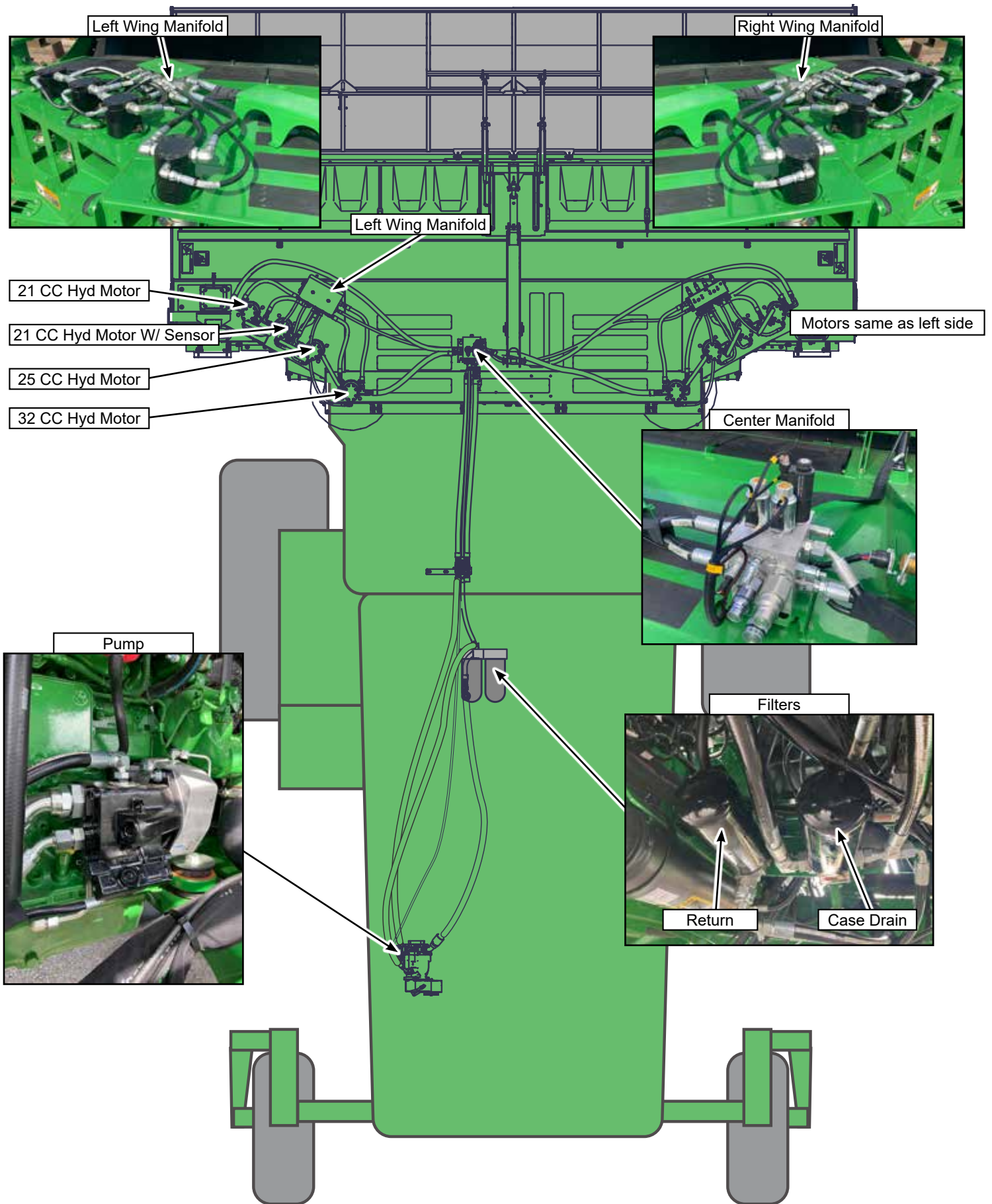

# Hydraulic Schematic

