

Operators Manual & Parts Book

Model WTR410

Model WTR510

Wrap Twine Remover

Patent Pending

D-211027DMC01
November 2023

A blue circular icon containing a white silhouette of a person sitting and reading a book or manual.	<p>! WARNING</p> <p>Read and understand operator's manual prior to operating this equipment.</p> <p>Failure to follow operation instructions could result in personal injury or damage to the equipment.</p>
--	---

Hillco Technologies, Inc. 1010 1st Ave. Nezperce, Idaho
Phone: 800.937.2461
www.hillcotechnologies.com

Table of Contents

General Information	3
Serial Number Location	3
Text and Illustrations	3
Abbreviations	3
Right and left Identification	3
Part Orders	3
Warranty	4
Safety	5
Operation	11
Best Practices	12
Adjustments	13
Knife Replacement	14
Hook Replacement	17
Spear Installation	19
Parts Book	20
Upper Frame	21
Lower Frame	22
Hook Arm	23
Hook Cartridge	24
Knife Arm	25
Knife Cartridge	26
Manifold	27
Hydraulic Junction	28
Cylinders	29
Decals	30
Electrical	31
Hydraulic & Electrical Schematics	32
Troubleshooting	33
Notes	34

Contact Information

Hillco Technologies, Inc.
1010 1st Avenue
Nezperce, Idaho 83543

www.hillcotechnologies.com

Phone 800-937-2461
208-937-2461
Fax 208-937-2280

email: support@hillcotechnologies.com

General Information

SERIAL NUMBER LOCATION



TEXT AND ILLUSTRATIONS

The arrangement of this parts catalog is for easy identification of parts. All parts are illustrated in exploded views in proper relation to each other. Some diagrams refer to other pages for further information. Reference numbers used in the illustrations refer to line numbers in the part lists. The part lists appear to the right or below all diagrams and correspond with those diagrams. Included in the part lists, along with the reference numbers are part numbers, part descriptions and the quantity of the part required per Wrap Twine Remover System.

ABBREVIATIONS

SN “Serial Number” refers to the serial number given to each WTR410/WTR510 by Hillco Technologies. See above for the Wrap Twine Remover System’s serial number location. This abbreviation is used interchangeably in both instances. Each Model WTR410/WTR510 uses the following serial number format:
xxxx (sequential numbers).

ASM “Assembly” refers to a whole grouping of parts (shown in the diagram corresponding with the page where “ASM” is shown unless otherwise noted). Some assemblies have parts that are sold separately, however some must be purchased as a single unit. Hillco Product Specialists will be able to assist you with any questions.

NS “Not Shown” refers to a part that is not depicted in the illustration.

RIGHT AND LEFT IDENTIFICATION

The reference to right-hand and left-hand in this catalog is identified by the operator sitting in the operator’s seat, looking toward the front of the machine (in normal forward travel).

PART ORDERS

Orders must specify product model, serial number, correct part number, complete description, quantity required, method of shipment, shipping address, and billing address.



Statement of Limited Warranty

Class III Warranty

Parts Only

Hillco warrants its Class III products to be free from defects in material and workmanship for a period of twelve (12) consecutive months following the warranty start date.

The warranty start date for Hillco Class III products is the date of the invoice, or the first date of use, whichever is earliest. Once the warranty period has begun, it cannot be stopped or interrupted.

Hillco warrants genuine Hillco replacement parts and components to be free from defects in material and workmanship for a period of ninety (90) consecutive days following the Hillco invoice date, or the remainder of the original equipment warranty period, whichever is longer.

Hillco's obligation under this parts warranty shall be limited to repairing or replacing, any part(s) that, in Hillco's judgment, shows evidence of such defect, to the original purchaser. This parts warranty does not cover any related labor associated with replacing parts deemed to be defective.

Limitations to Warranty

This warranty does not cover:

- 1) Any product damaged by accident, abuse, misuse, negligence, or improper maintenance.
- 2) Any unauthorized product alteration or modification.
- 3) Any unauthorized repairs made with parts other than genuine Hillco parts unless specifically authorized by Hillco.
- 4) Any repairs performed by anyone other than Hillco or an authorized Hillco dealer unless specifically authorized by Hillco.
- 5) Any claims directly resulting from improper installation, except those installations performed by Hillco.
- 6) Any labor costs associated with the defective part(s).

Warranty Procedure

Hillco Class III Warranty Registration Card must be completed and submitted by retail customer within thirty (30) days of purchase.

All warranty work must be performed, and claims submitted, within thirty (30) days of the occurrence of the claim and within the warranty period.

All parts removed during warranty repair should be held for a period of sixty (60) days after the warranty claim has been submitted to Hillco.

Hillco reserves the right to either inspect the product at the original retail purchaser's location, or the authorized Hillco's dealer's location; or require it to be returned to Hillco, transportation charges prepaid, for inspection.

To file a warranty claim, email support@hillcotechnologies.com with the following information:

- Your full name and phone number
- Proof of purchase
- Description of issue
- Serial number and/or part number(s) of items needing replaced, and
- If available, include any photos that can assist to describe the issue.

Limitation of Liability

Hillco makes no express warranties other than those, which are specifically described herein. Any description of the goods sold hereunder, including any reference to buyer's specifications and any descriptions in circulars and other media published by Hillco is for the sole purpose of identifying such goods and shall not create an express warranty that the goods shall conform to such description.

THIS WARRANTY IS EXPRESSLY IN LIEU OF ALL OTHER WARRANTIES EXPRESSED OR IMPLIED. There are no implied warranties of merchantability or fitness for a particular purpose. This warranty states Hillco's entire and exclusive liability and buyer's exclusive remedy for any claim for damages in connection with the sale or furnishing of Hillco products, their design, suitability for use, installation, operation, or for any claimed defects herein. **HILLCO WILL IN NO EVENT BE LIABLE FOR ANY INCIDENTAL OR CONSEQUENTIAL DAMAGES WHATSOEVER, NOR FOR ANY SUM IN EXCESS OF THE PRICE RECEIVED FOR THE GOODS FOR WHICH LIABILITY IS CLAIMED.**

Neither representative of Hillco nor any dealer associated with Hillco has the authority to change the items of this warranty in any manner whatsoever, and no assistance to purchaser by Hillco in the repair or operation of any Hillco product shall constitute a waiver of the conditions of this warranty, nor shall such assistance extend or revive it.

Hillco reserves the right to make improvements in design or changes in specifications at any time, without incurring any obligation to owners of units previously sold.

SAFETY ALERT SYMBOL





This Safety Alert symbol means
ATTENTION! BECOME ALERT! YOUR SAFETY IS INVOLVED!

The Safety Alert symbol identifies important safety messages on the Hillco Wrap Twine Remover and in the manual. When you see this symbol, be alert to the possibility of personal injury or death. Follow the instructions in the safety message.

SIGNAL WORDS

Note the use of the signal words DANGER, WARNING, and CAUTION with the safety messages. The appropriate signal word for each message has been selected using the following guidelines:

 DANGER	DANGER - An immediate and specific hazard, which WILL result in severe personal injury or death if the proper precautions are not taken.
 WARNING	WARNING - A specific hazard or unsafe practice, which COULD result in severe personal injury or death if proper precautions are not taken.
 CAUTION	CAUTION - Unsafe practices which COULD result in personal injury if proper practices are not taken, or as a reminder of good safety practices.
NOTICE	NOTICE - is used to address practices not related to physical injury.

OPERATION SAFETY

1. Read and understand the Operator's Manual and all safety labels before operating the Wrap Twine Removal system.
2. Make sure that all controls are in the neutral position before starting the tractor.
3. Clear the area of all bystanders, especially children, before starting the system and during operation.
4. Make sure all safety shields are in place before operating the Wrap Twine Remover. Never operate the machine with the shields removed.
5. Keep hands, feet, hair and clothing away from all moving and/or rotating parts.
6. Stay seated in the cab during operation.
7. Operate controls only when sitting in the seat of the tractor.
8. Always travel at a safe speed. Use caution when making turns or traversing ditches.

HYDRAULIC SAFETY

1. Do not search for high-pressure hydraulic leaks without hand and face protection. A tiny, almost invisible leak can penetrate skin, thereby requiring immediate medical attention.
2. Use cardboard or wood to detect leaks – never your hands!
3. Before inspecting the hydraulic system of the Wrap Twine Remover system, install the safety stops where applicable.
4. Before operating the WTR, ensure that there are no obstructions between or around the arms.
5. Maintain proper hydraulic fluid levels.
6. Ensure all fittings and hoses are in good repair.



SERVICING AND MAINTENANCE SAFETY

1. Review the Operator's Manual and all safety items before servicing or maintaining the Wrap Twine Remover.
2. Stop the engine, wait for any moving parts to stop, block the tires, and the cylinder areas before servicing, repairing, adjusting, or maintaining the Wrap Twine Remover system.
3. Place Selector switch to middle position and set hydraulics to float (if possible) to relieve system pressure.
4. Hydraulic oil is under pressure. Use caution when dealing with the hydraulic system.
5. Keep hands, feet clothing and hair away from all moving and/or rotating parts.
6. Clear the area of bystanders, especially children, when carrying out any maintenance, repairs or making any adjustments.

HIGHWAY OPERATION AND TRANSPORT SAFETY

1. Check with local authorities regarding transport on public roads. Obey all applicable regulations and laws.
2. Check clearance elevations and widths of implement for travel near power lines, bridges, trees, etc.
3. Always travel at a safe speed. Use caution when making corners or meeting traffic.
4. WTR is not designed to transport bales long distances on public roads.

READ OPERATOR'S MANUAL SYMBOL

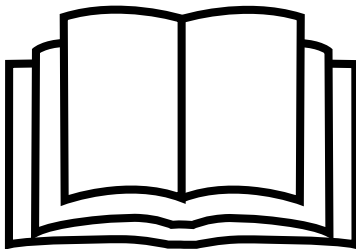

Decals, which display the —Read Operator's Manual symbol, are intended to direct the operator to the Operator's Manual for further information regarding maintenance, adjustments and/or procedures for particular areas of the Wrap Twine Remover. When a decal displays this symbol refer to the Operator's Manual for further instructions.

Safety Labels

Familiarize yourself with the location of all safety labels. Read them carefully to understand the safe operation of your machine.

TO APPLY NEW OR REPLACEMENT LABELS

1. Make sure the label area is smooth by removing any debris such as dirt or old labels.
2. Wash the area with soap and water and then dry it thoroughly.
3. After the area has completely dried, peel the backing off the safety label and place it onto the cleaned area.
4. Make sure all areas of the label have adhered to the machine by pressing down on the entire face of the label, including the corners.

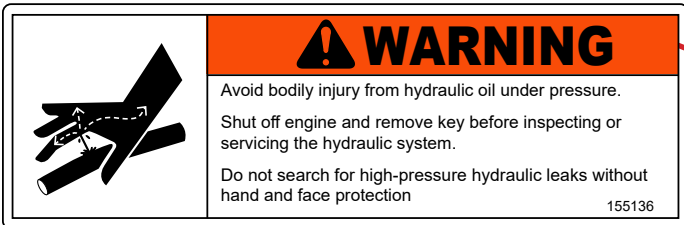
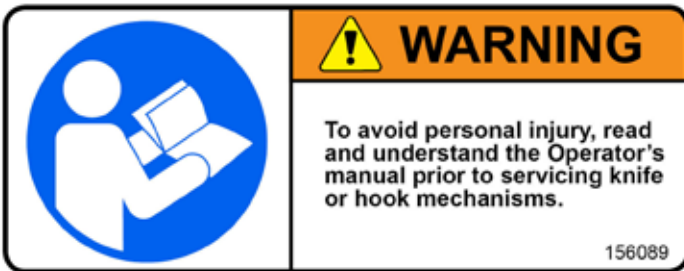
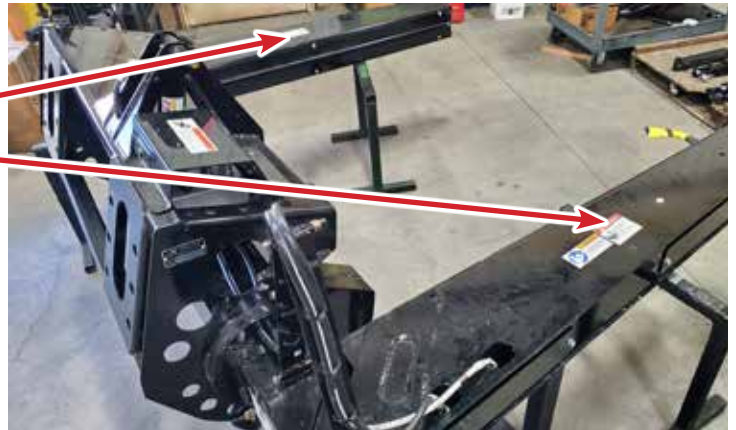

! DANGER



PINCH POINT HAZARD

- Keep hands, feet and body away from moving parts.
- Do not stand or climb on machine when operating.

155139



NOTICE

Maximum Lifting Capacity:

**3000 lbs
(1360 kg)**

156088



! WARNING *Do not cycle the knife or hooks when someone is near the WTR.*

Hydraulics, Electrical, and Implement connections.

Attach the Wrap Twine Remover to your loader as per the instructions in your loader's Operator's Manual. Connect the two hydraulic hoses to the service ports on the loader tractor. (If your tractor is not equipped with service ports at the front of the loader you can route hoses from the rear of the tractor, these hoses are not included in the kit.) Connect the electrical plug near the manifold and the system is ready for use.

Operation:

The WTR has three functions controlled by a switch box in the cab.

Bale Squeeze – Used to squeeze the bale and position the hooks and knife into position to grab and cut the bale twine/wrap.

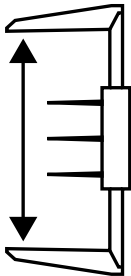

Rotate – Used to rotate the squeeze arms out of the way when handling bales that are tightly stacked

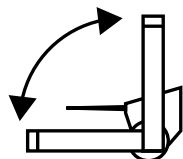

Cut – Cycles a series of hooks on the left arm and a knife on the right arm. The hooks grab into the bale and capture the twine/wrap while the knife simultaneously cuts the twine/wrap.

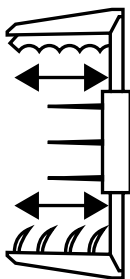

NOTICE

If WTR power is connected to permanent power, leave the switch in the center (rotate) position to avoid draining the battery.

Best Practices

Position the bale squeeze arms so that they are level with the bale and slightly below the bale center line.



After cutting the bale covering, open the bale squeeze arms fully to put some tension into the twine/wrap. Next rotate the arms upward to pull the wrap free from the bale. Then tip the bale downward and allow it to slide forward off the spears.



Adjustments:

The hook bank can be moved in/out of the left arm to adjust how deep the hooks are reaching into the bale. For twine wrapped bales it is best to have the hooks reach further into the bale to ensure they get behind each string. For round bales with net wrap the hooks can be adjusted inwards to reduce the amount of hay that is trapped by the hooks.

Hook Depth Adjustment
Use 9/16" Socket



Knife blade replacement

Use the following procedure to safely remove the knife cartridge for blade replacement

Open the arms at least 1 foot from their fully closed position then shut off the vehicle engine and remove the key.

WARNING

The knife blade is very sharp! Wear proper protective equipment while handling the knife.



Open the rear access cover (A) on the outside of the arm and disconnect the rod end of the cylinder from the knife cartridge. Place one of the keeper pins (C) from the cylinder through the hole at the center of the knife cartridge where the blade extends out. This will help prevent the blade accidentally extending outward while the cartridge is removed.



If equipped with the net wrap hook, open the front access cover (B) and disconnect the struts from the rocker assembly. The struts will be removed with the knife cartridge.

NOTICE

If the blade is cycled while the safety pin is in place, irreparable damage will occur.



Remove the six bolts (A) from the inside face of the cartridge then remove the cartridge taking extra care to ensure that the knife blade remains inside the cartridge. You will have to tip the cartridge downward to clear the arm frame.

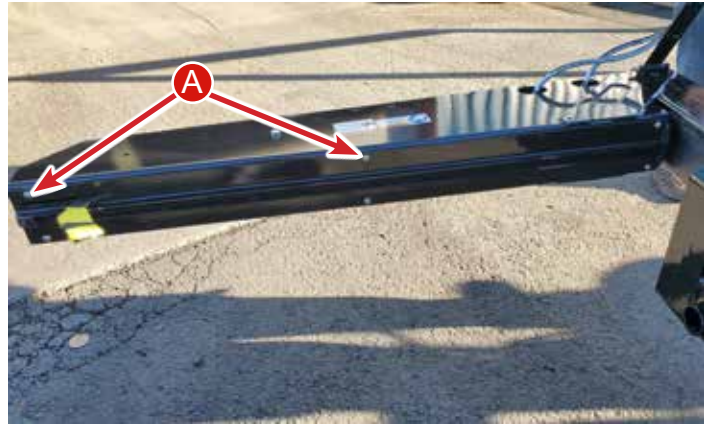

Set the cartridge on a sturdy work surface and remove the linkages (B) that connect the knife holder to the cartridge.



From the outside of the cartridge remove the safety pin (C) and then the knife holder



Slide the knife holder forward then rotate to remove the knife holder from the cartridge frame as shown.



Using a T30 wrench remove the screws (A) holding the blade to the knife holder. When re-installing the blade make sure to match the angle of the blade to the angle of the knife holder at the front and rear. Use locktite on all bolts and tighten them to 75 in-lbs.



Assembly is the reverse of the process above.

Hook replacement

Use the following procedure to safely remove the hook cartridge for hook replacement



CAUTION

Be aware of pinching hazards while handling the hook cartridge.

Open the arms at least 1 foot from their fully closed position. Ensure that the hooks are fully retracted. Shut off the vehicle engine and remove the key.



Open the access cover (A) on the outside of the arm and disconnect the rod end of the cylinder from the hook cartridge.

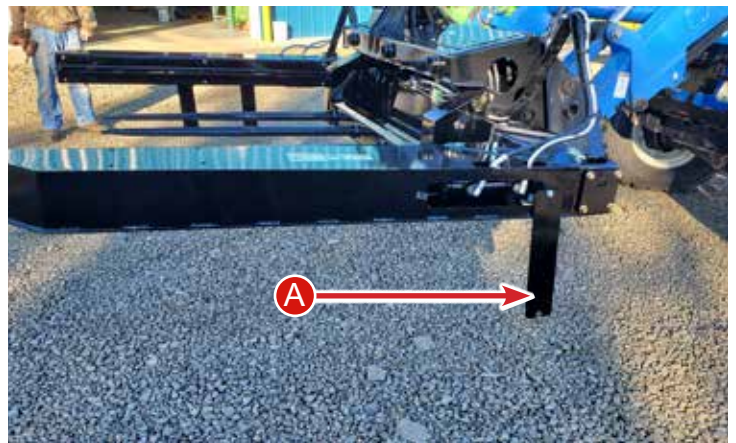

Remove the six bolts (B) from the inside face of the cartridge then remove the cartridge

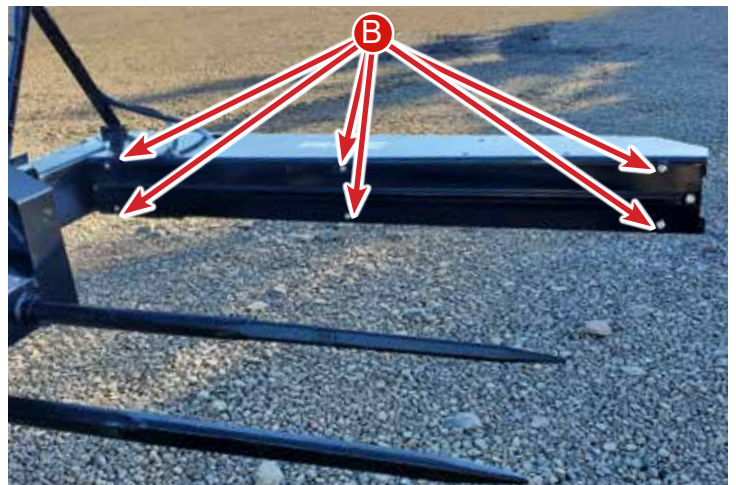

Set the cartridge on a sturdy work surface. The hooks can be removed one at a time by removing the two bolts that attach them to the pivot frame and actuator arm. It is recommended that you replace the bushing when replacing the hook.



When re-installing the hooks, tighten the bolt (A) that passes through the pivot bushing snugly but only tighten the bolt (B) on the actuation arm tight enough that the bolt can still be turned freely by hand. If the bolts to the actuation arm are too tight the mechanism can bind.

Assembly is the reverse of the process above.

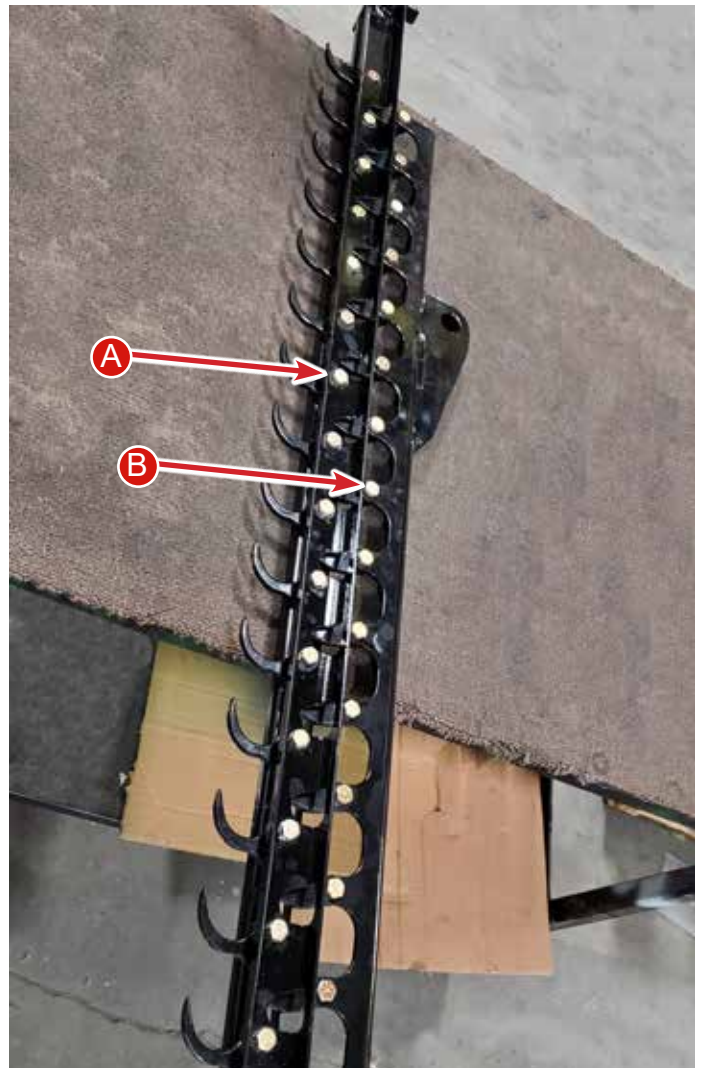

Spear Installation

The WTR comes with and three upper (A) and an optional four lower (B) spear locations. Up to seven spears in any combination can be installed. Three spears are included. An additional fourth spear is included with the optional lower mount.

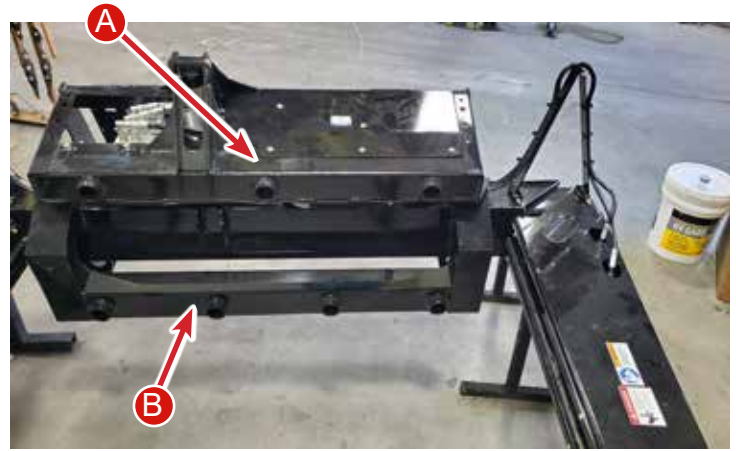

Setup

Read this prior to beginning the setup procedure:

Due to the variety of different loader options on the market, the WTR is shipped without service hoses from the manifold to the loader hydraulics. Secondly, if your tractor does not have auxiliary hydraulics at the loader then hoses from the rear remotes will need to be routed to the WTR. It is advisable to have these hoses made prior to beginning the system setup.

Hillco recommends a 3/8 inch service hose with 90° -8 (1/2") SAE Oring Face seal fittings on one end and the quick coupler option of your choice on the other end.

Step 1:

Unpackaging and Inventory:

Unpack the WTR system, including the boxed items, and compare the items to the inventory list below. If there are any damaged or missing items contact Hillco Technologies, Inc. at 1-800-937-2461 for assistance.

Item Description	Quantity	Weight (Pounds)
Center Assembly	1	640
Hook Arm Assembly	1	200 (WTR510), 175 (WTR410)
Knife Arm Assembly	1	200 (WTR510), 175 (WTR410)
Bale Spears	2*	30
--Boxed Items --		9
Hose Support	4	
Operators Manual	1	
3/4-10 x 2-1/2" Bolt, Grade 8	8	
3/4-10 Stover Nut, Grade 8	8	
Switch Box Assembly	1	
Harness, Switch box to Valve	1	
Ram-Mount U-bolt kit	1	
Ram-Mount Double Swivel Arm	1	
5/16-18 x 3-1/2" Bolt, Grade 5	6	
5/16 Ny-lock Nut, Grade 8	6	

* Additional spears are available at the time of order.

You will also need the loader adapter kit chosen at the time of ordering. It may have been shipped separately.

Step 2:

Rotating the center assembly:

Using one of the spears as a lever, rotate the center assembly upwards to provide access to the rear of the frame.



The spear can rest against the ground to help stabilize the center assembly.



Step3:

Installing service hoses:

Locate and remove the two caps from the fittings on the rear of the manifold. (It may be easier to remove the manifold cover using a T45 torx bit).

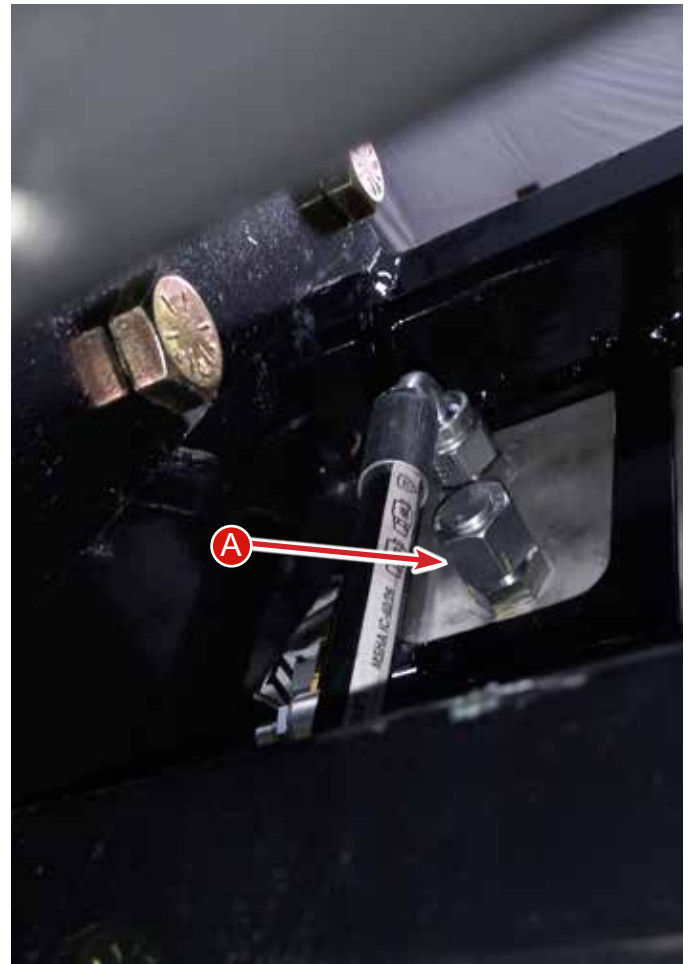

Connect the hoses to the fittings at the rear of the manifold then route the service hoses towards the right side of the center frame. The hoses should exit under the right side of the manifold cover. (B)



Step 4

Installing loader adapter

Locate the loader adapter kit. It should include a left and right adapter plate of your choice along with 12ea. $\frac{3}{4}$ -10 x 1-3/4 bolts and nylock nuts. (A) Position the left plate between the mounting ears at the rear of the frame and install the 6 bolts from the inside and start the lock nuts. Tighten all nuts using an impact wrench and repeat this process for the right plate.

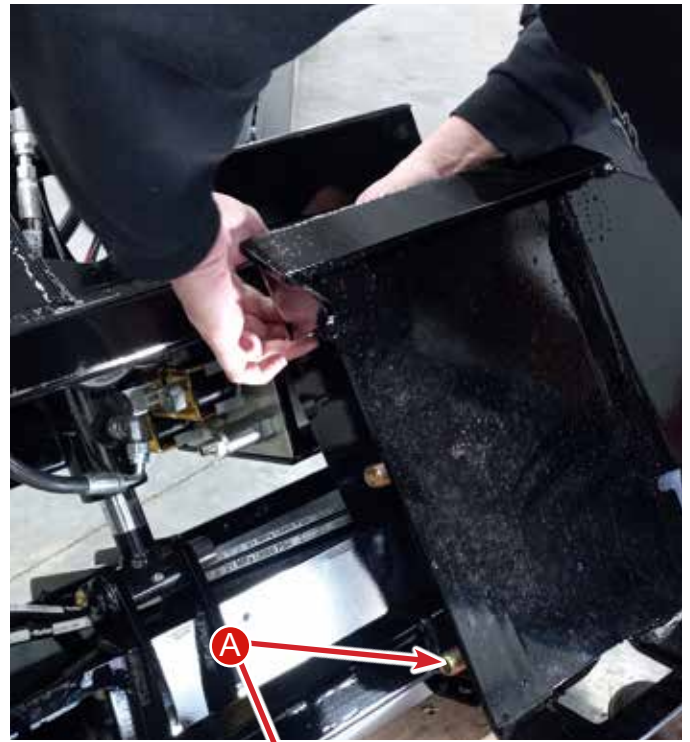

Note: The skidsteer mount is shown, your kit may vary.



Step 5.

Pickup the center frame and secure it to your loader tractor.



Step 6:

Installing Knife Arm.

Place a nail or screw driver through the hole in the knife cartridge lip (A) to prevent the knife blade from extending accidentally.



Cut the zip tie (B) holding the arm hoses in place and set the hoses out of the way for now.



Lower the center frame with your loader tractor and position the arm near the right side mount plate so that it can be bolted in place. There are two positions to install the arms. The narrow position (shown) is optimal for round bales, while the wide position is intended for large square bales that are 8 feet long or longer.



If using the narrow position, make sure the red indicator rod will pass through the guide hole the arm mount. Install all bolts with the nuts at the rear and tighten with an impact wrench. Make sure to hit each bolt multiple times to verify they are properly tightened.

Remove the screw driver from from the knife cartridge lip.



Step 7:

Installing the Hook Arm

Cut the zip tie holding the arm hoses to the mounting plate and set them aside.

Position the hook arm on the shipping pallet and align it with the left side mount. As with the right side, there are two positions for mounting the arm. Typically, the arms are mounted into the same position on each side but this is not required.

Install the bolts with the nuts facing the rear of the unit and tighten with an impact wrench. Again, tighten each bolt multiple times to ensure they are all tightened properly.



Step 8:

Installing hose guides:

Locate the 4 hose guides from the box as well as 6ea. 5/16 bolts and nuts. Install the hose guides as shown and tighten. Note that the bolts must be left loose enough to allow the guides to move freely as the arm extends and retracts.

Repeat this process on the opposite side



Step 9:

Connecting arm cylinder hoses:

Remove the rear cover from the side of the hook arm to gain access to the hydraulic cylinder inside the arm.



Route the hoses from the center frame, over the top of the guides and through the two holes in the top of the arm. Connect them to their corresponding ports on the arm cylinder. The ends of the hoses are different to prevent connecting them incorrectly. Note that you may have to loosen the fittings in the cylinder to adjust them to the proper angle.

Zip tie the hoses to the guides then tighten all connections near the arm cylinder. Reinstall the rear arm cover then repeat this process for the opposite side.



Step 10:

Installing spears

If you are using the top spear mount you will need to remove the manifold and hose covers using a T45 torx bit. If you are using the optional lower spear mount then you will not need to remove the covers.

Insert the spears into the desired bushings and secure them with the included nut. Be sure to install the nut so the cone shaped end is towards the bushing. Re-install the covers if necessary.



Step 11:

Installing electrical.

Find a convenient location inside the cab to mount the switch box and secure it using the provided Ram mounts. You will need to provide 12 volts – 5 amps to the orange wire and ground to the black wire. Hillco recommends connecting the switch box to a keyed power source to avoid accidentally draining your tractors battery if the switches are left on.



Connect the extension harness to the manifold harness (already installed) then route the free end down the side of your loader to the switch box in the cab and connect the two together. Be sure to secure the harness with zip ties so it won't rub or pinch as the loader is used.



Startup:

Please read through the following procedure fully prior to attempting the first startup of your WTR.



Rotate:

Make sure there are no people standing near the unit. Start the tractor, verify the switch box is in the center position then slowly provide oil to the WTR. If nothing happens, try reversing the hydraulics. The arms should slowly rotate upwards as you apply oil. Once the arms have rotated fully upwards, slowly reverse the hydraulic flow to lower them. Repeat these 3 or 4 times to remove all air from the cylinder. It is important to do this step slowly until all air is removed from the system to prevent the arms from rotating too fast and damaging the cylinder.



Squeeze:

Change the switch to the bale squeeze position (A red light should illuminate on the switch). Slowly provide oil to the WTR. If nothing happens slowly reverse the flow. The arms will start to extend, most likely one at a time. It is normal for the arms to chatter as the air is bled from the system. Once the arms are fully extended Hillco recommends that a dry lubricant, such as graphite, be sprayed liberally onto the arm tubes. Cycle the arms fully 3 or 4 times to purge all air from the system.



Cut:

Change the switch to the cut position. (A red light should illuminate on the switch). Double check no one is standing near the WTR, then slowly provide oil. As before, if nothing happens try reversing the flow. You should be able to see the red indicator rod at the rear of the right arm extend rearward. If you position the loader properly, you can see the hooks and knife deploy.

Note that the knife blade is shipped with tape over it for safety. Now is a good time to carefully remove the tape from the knife edge. The best way to do this is to slowly cycle the cut mechanism and stop as the blade is exposed. This will provide access to remove the tape. Cycle the knife and hook 2 – 3 times to purge air from the system.

Shut down the tractor engine and inspect the WTR for any oil leaks. Hillco also recommends checking the hydraulic fluid level w.

Thank you for purchasing your Hillco Technologies, Inc. product. Please contact our customer support department with any questions regarding your WTR system.

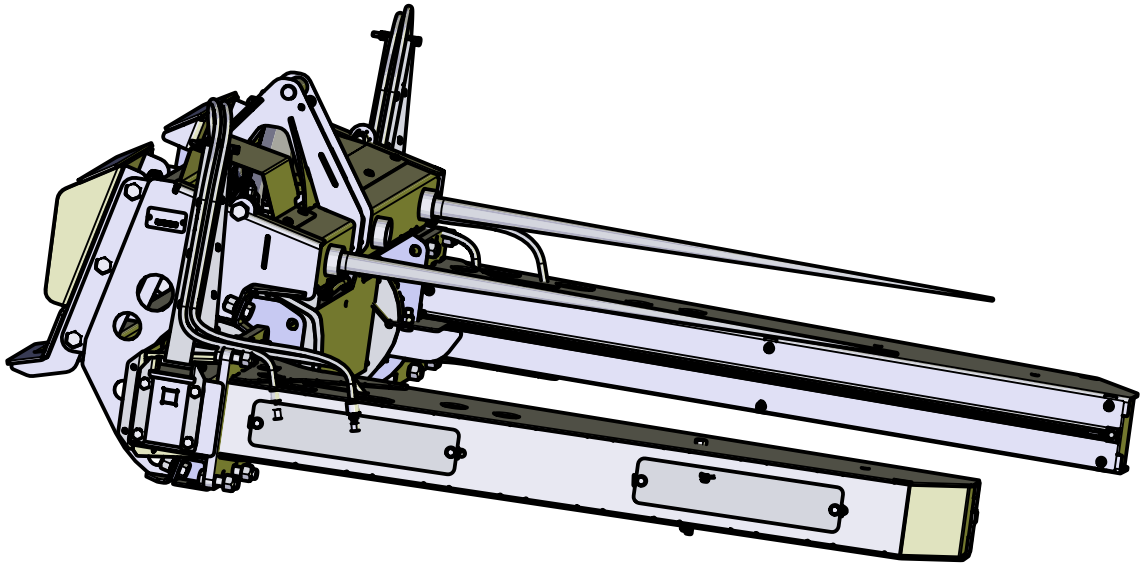

Model WTR410 WTR510 Wrap Twine Remover Parts Manual

D-211027DMC01

Upper Frame

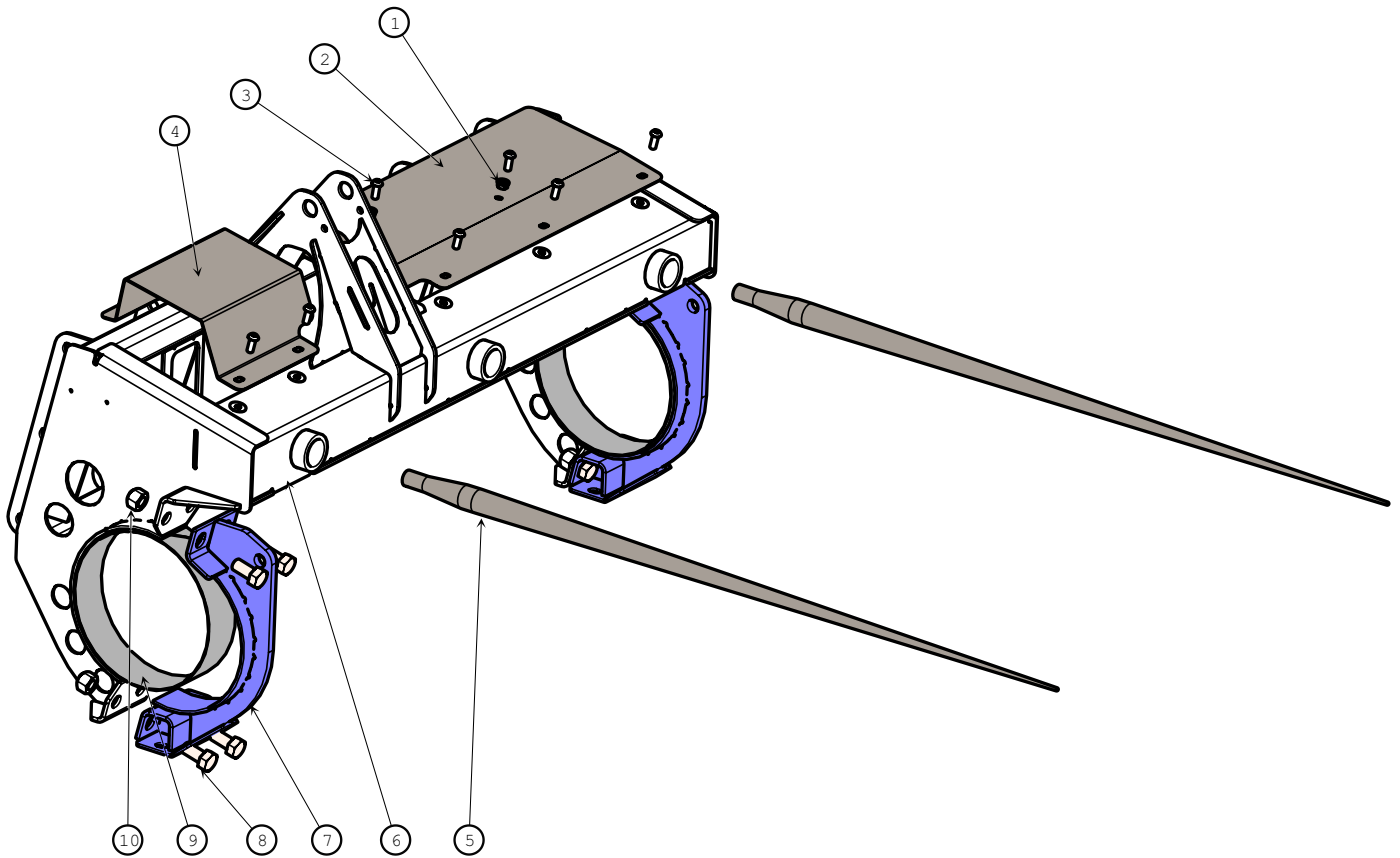

BOM ID	Part No.	Qty	Description
1	216.006	2	NUT,HX,FL,GR8 3/8-16
2	1363733	1	COVER, LEFT
3	257.006.016	7	SCREW, PHM, TX, 3/8-16 X 1"
4	1363744	1	COVER, RIGHT
5	156048	2	BALE SPEAR, 49 INCH
6	1355204	1	FRAME
7	1361633	2	PIVOT CLAMP
8	102.012.024	8	BOLT,HX,GR8 3/4-10 X 1-1/2"
9	1366161	2	ROTATE BUSHING
10	188.012	8	STV,GR8 3/4
11	1363733	1	COVER, LEFT

Lower Frame

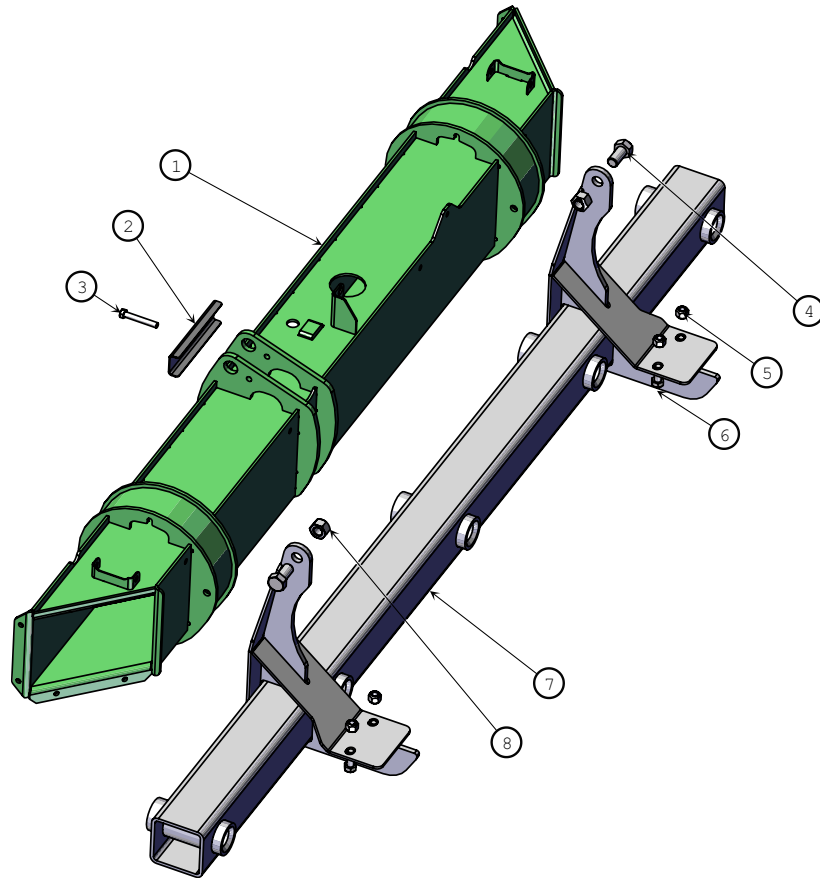

BOM ID	Part No.	Qty	Description
1	1355873	1	CLAMP FRAME
2	1361961	1	PIN LOCK, CLAMP CYLINDER
3	102.006.040	1	BOLT, HX, GR8 3/8-16 X 2-1/2
4	102.012.024	2	BOLT,HX,GR8 3/4-10 X 1-1/2"
5	188.008	4	NUT,HX,STV,GR8 1/2
6	102.008.020	4	BOLT,HX,GR8 1/2-13X1-1/4
7	1377391	1	LOWER SPEAR FRAME
8	188.012	2	NUT, HX,STV,GR8 3/4-10

Bale Squeeze Tube

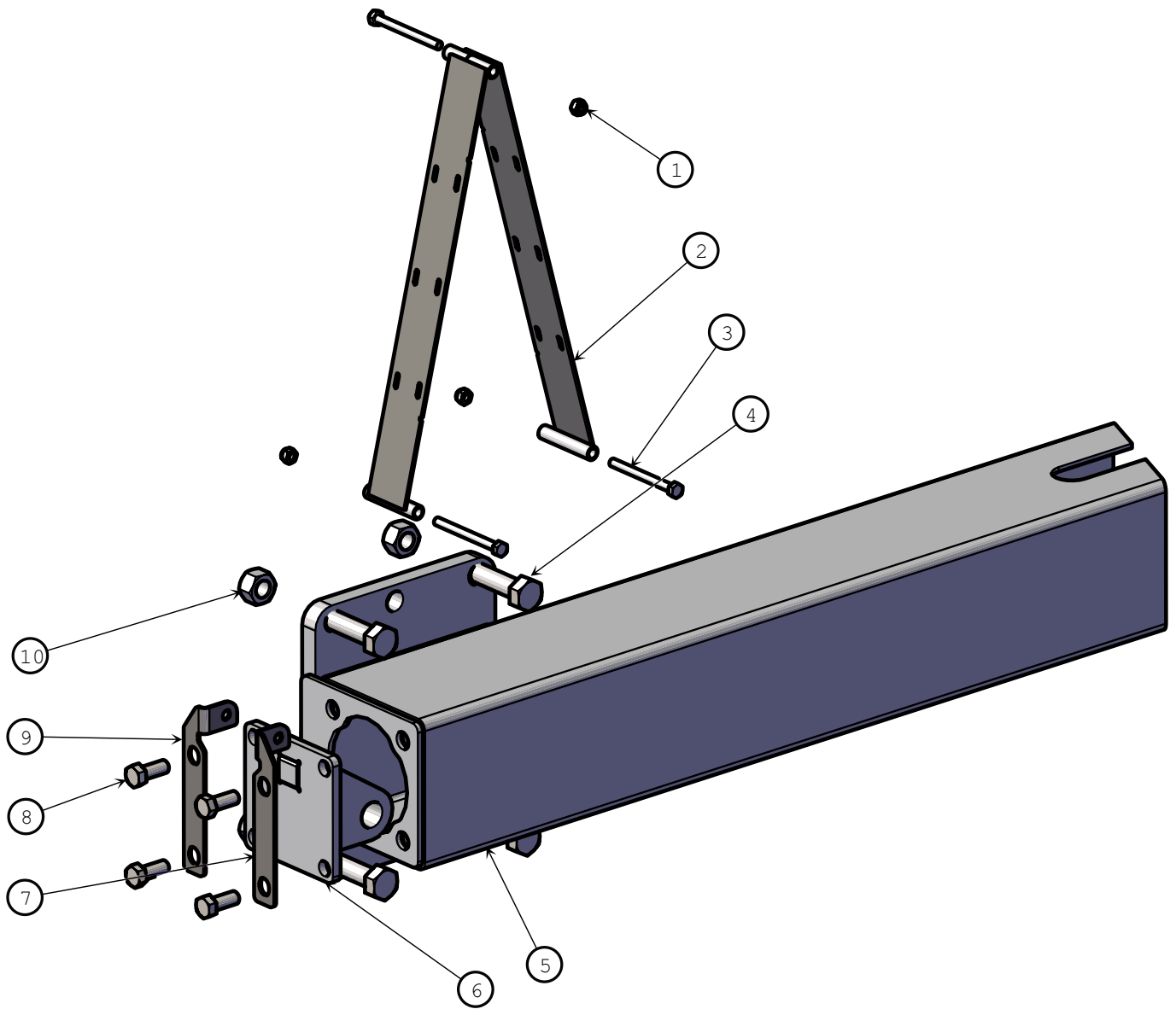

BOM ID	Part No.	Qty	Description
1	187.005	3	NUT,HX,NYL,GR8 5/16
2	1356012	2	SUPPORT, HOSE
3	101.005.056	3	BOLT, HX, GR5 5/16-18 X 3.5"
4	102.012.040	4	BOLT,HX,GR8 3/4-10X2-1/2"
5	1376741	1	CLAMP TUBE
6	1355843	1	ROD MOUNT, CLAMP CYL
7	1376791	1	BASE, HOSE SUPPORT A
8	102.008.020	4	BOLT,HX,GR8 1/2-13X1-1/4
9	1377491	1	BASE, HOSE SUPPORT B
10	188.012	4	NUT, HX,STV,GR8 3/4-10

Hook Arm

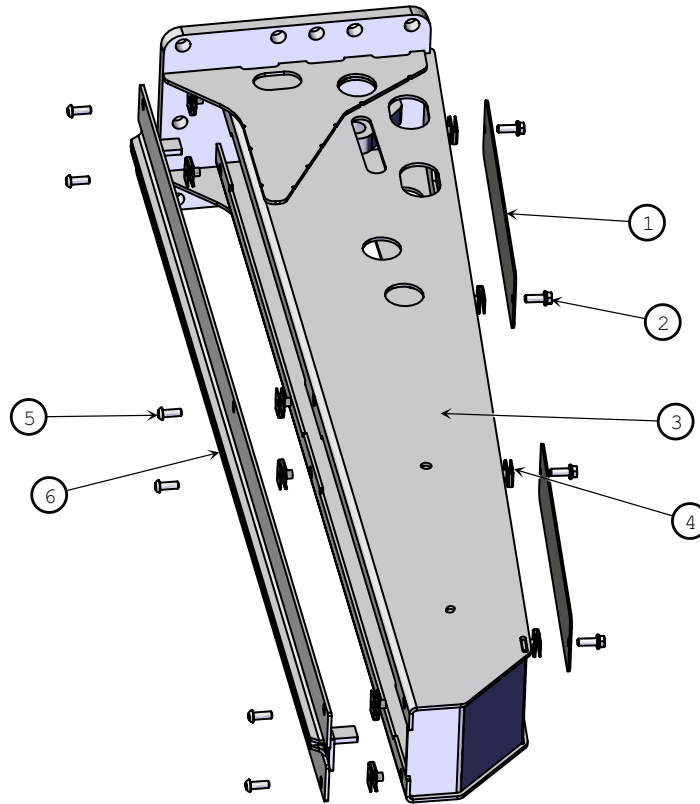

BOM ID	Part No.	Qty	Description
1	1365591	2	COVER, CYLINDER ACCESS
2	111.006.016	4	BOLT, HX, FL, GR5 3/8-16X1
3	1377501	1	WTR410 CLAMP ARM
*ns	1376841	1	WTR510 CLAMP ARM
4	155993	10	U-NUT, TINNEMAN, EXTRUDED 3/8-16
5	257.006.016	6	SCREW, PHM, TX, 3/8-16 X 1"
6	1365472	1	HOOK MOUNT

Hook Cartridge

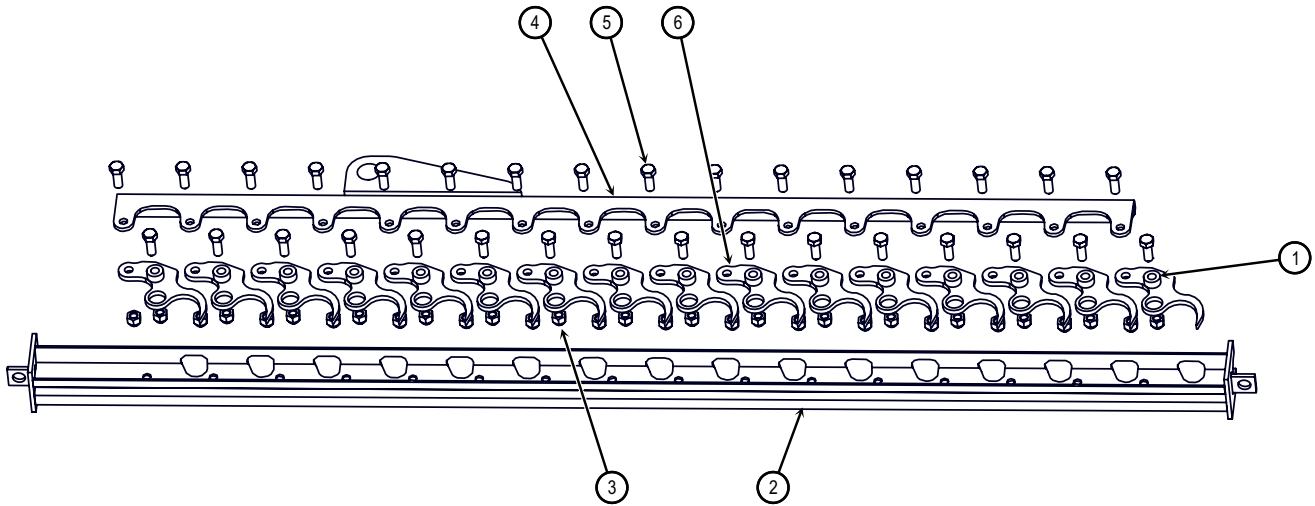

WTR410			
BOM ID	Part No.	Qty	Description
1	156082	16	SPACER, UNTHREADED ZINC PLATE, 1/2" ID X 3/4" OD X 3/8"L
2	1365462	1	HOOK FRAME
3	187.006	32	NUT,HX,NYL,GR8 3/8
4	1365482	1	HOOK ACTUATOR
5	102.006.016	32	BOLT,HX,GR8 3/8-16X1
6	1356184	16	HOOK
WTR510			
BOM ID	Part No.	Qty	Description
1	156082	16	SPACER, UNTHREADED ZINC PLATE, 1/2" ID X 3/4" OD X 3/8"L
2	1366471	1	HOOK FRAME
3	187.006	40	NUT,HX,NYL,GR8 3/8
4	1367361	1	HOOK ACTUATOR
5	102.006.016	40	BOLT,HX,GR8 3/8-16X1
6	1356184	20	HOOK

Knife Arm

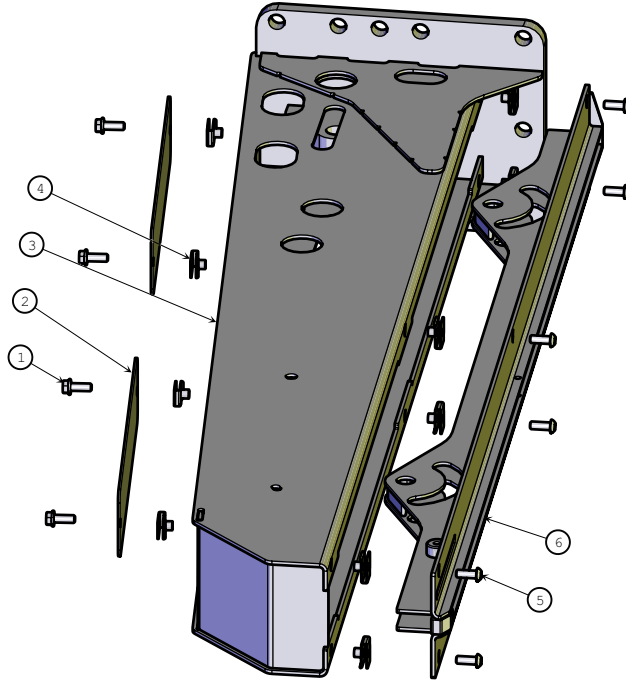

WTR410			
BOM ID	Part No.	Quantity	Description
1	111.006.016	4	BOLT,HX,FL,GR5 3/8-16X1
2	1365591	2	COVER, CYLINDER ACCESS
3	1377501	1	CLAMP ARM
*NS	1376841		CLAMP ARM WTR510
4	155993	10	U-NUT, TINNEMAN, EXTRUDED 3/8-16
5	257.006.016	6	SCREW, PHM, TX, 3/8-16 X 1"
6	1365503	1	KNIFE CARTRIDGE
*ns	1366413	1	KNIFE CARTRIDGE WTR510

Knife Cartridge

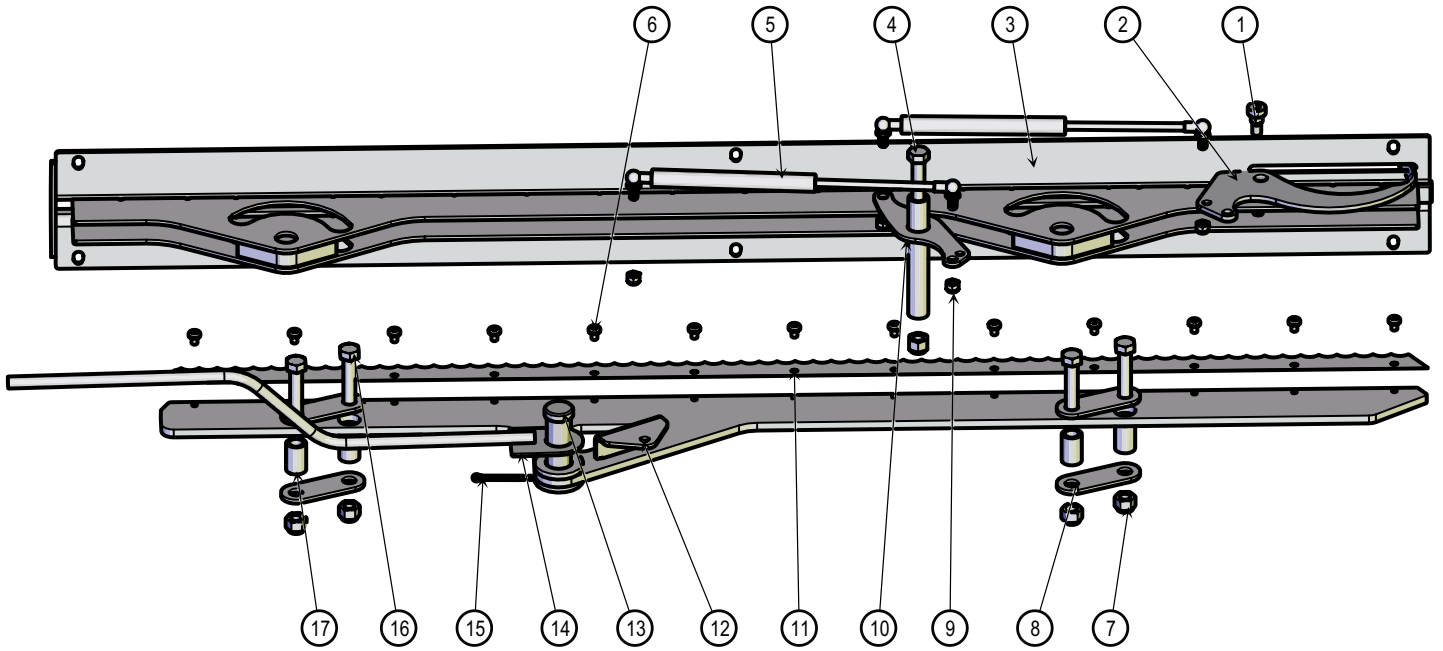

Knife Cartridge

WTR410			
BOM ID	Part No.	Qty	Description
1	208.08.006	1	BOLT,SHL 1/2 X 3/8 SHLDR X 3/8-16 X 5/8 THD
2	1369601	1	EDGE HOOK
3	1365503	1	KNIFE CARTRIDGE
4	101.008.112	1	BOLT,HX,GR5 1/2-13X11
5	156081	2	GAS SPRING, 50 LBF, 13.19" EXTENDED X 4.92" STROKE
6	255.04.006	13	SCREW PHM, TX,SERR 1/4-20X3/8"
7	187.008	5	NUT,HX,NYL,GR8 1/2-13
8	1356093	4	KNIFE LINK
9	187.005	4	NUT,HX,NYL,GR8 5/16
10	1369611	1	ROCKER, EDGE HOOK
11	1366402	1	BLADE, BEVELED
12	1369592	1	KNIFE HOLDER
13	156261	1	PIN, CYLINDER, 1 OD X 2-15/16 LONG
14	1376951	1	KNIFE INDICATOR
15	142.003.032	1	PIN,COTTER 3/16
16	102.008.040	4	BOLT,HX,GR8 1/2-13 X 2-1/2
17	10060.08.00030	4	PIPE,BARE,SCH80 1/2 X 1-7/8
WTR510			
BOM ID	Part No.	Qty	Description
1	208.08.006	1	BOLT,SHL 1/2 X 3/8 SHLDR X 3/8-16 X 5/8 THD
2	1369601	1	EDGE HOOK
3	1366413	1	KNIFE CARTRIDGE
4	101.008.112	1	BOLT,HX,GR5 1/2-13X11
5	156081	2	GAS SPRING, 50 LBF, 13.19" EXTENDED X 4.92" STROKE
6	255.04.006	16	SCREW PHM, TX,SERR 1/4-20X3/8"
7	187.008	5	NUT,HX,NYL,GR8 1/2-13
8	1356093	4	KNIFE LINK
9	187.005	4	NUT,HX,NYL,GR8 5/16
10	1369611	1	ROCKER, EDGE HOOK
11	1372771	1	BLADE,BEVELED,LONG
12	1376631	1	KNIFE HOLDER, LONG
13	156261	1	PIN, CYLINDER, 1 OD X 2-15/16 LONG
14	1376951	1	KNIFE INDICATOR
15	142.003.032	1	PIN,COTTER 3/16
16	102.008.040	4	BOLT,HX,GR8 1/2-13 X 2-1/2
17	10060.08.00030	4	PIPE,BARE,SCH80 1/2 X 1-7/8

Manifold

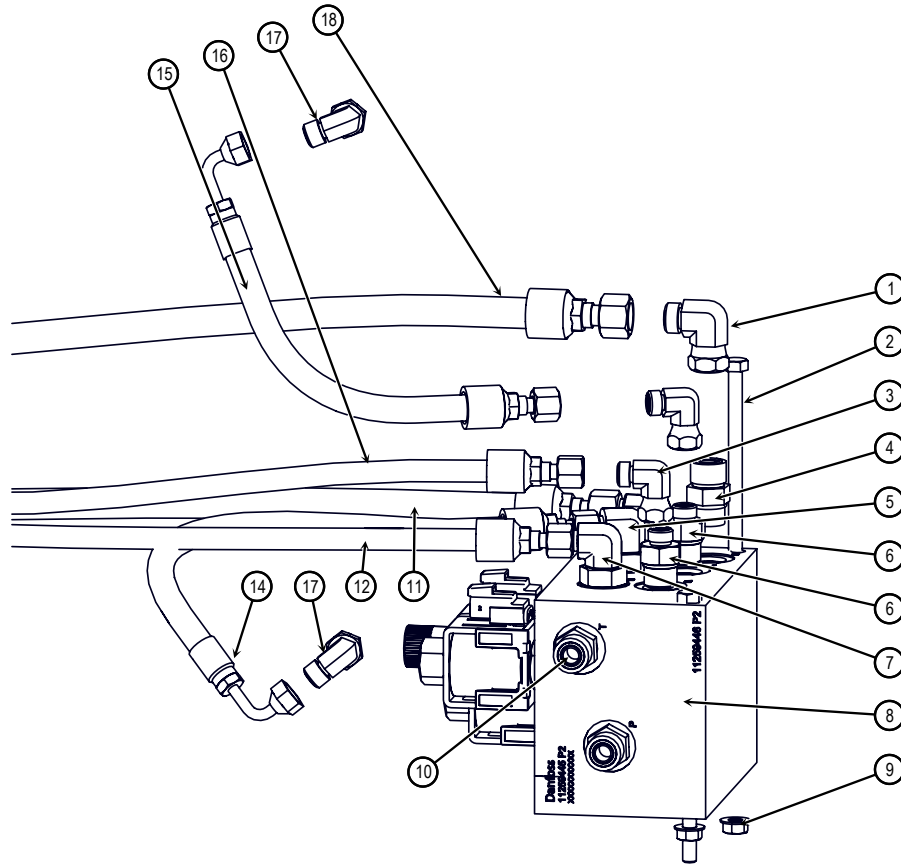

BOM ID	Hillco Part No.	Qty	Description
1	1006.06.06	1	-6FORFS x -6MORFS
2	102.005.096	2	BOLT,HX,GR8 5/16-18X6
3	1006.04.04	2	-4FORFS x-4MORFS
4	1001.08.06	1	HA,STR -8MORB X -6MORFS
5	1003.08.06	1	HA,90° -8MORB X -6MORFS
6	1001.08.04	2	HA,STR -8MORB X -4MORS
7	1003.08.04	2	HA,90° -8MORB X -4MORFS
8	156225	1	MANIFOLD ASM, DIVERTER VALVE WITH RELIEF & ORIFICE
9	216.005	1	NUT,HX,FL,GR8 5/16-18
10	1001.08.08	1	HA,STR -8MORB X -8MORFS
11	1368531	1	100R17AR-06X58, -6 FORS STR X -8 FORS 90
12	1368461	1	100R17AR-04X60, -4 FORS STR X -4 FORS 90
13	155059	1	SWEEP90° D21MM,
14	1368471	1	100R17AR-04X17, -4 FORS STR X -4 FORS 90
15	1368481	1	100R17AR -04X13", -4FORS STR X -4FORS 90°
16	1368451	1	100R17AR-04X63, -4 FORS STR X -4 FORS 90
17	1003.06.04	2	HA,90° -6MORB X -4MORFS
18	1368541	1	100R17AR-06X63-1/2, -6 FORS STR X -8 FORS 90

Hydraulic Junction

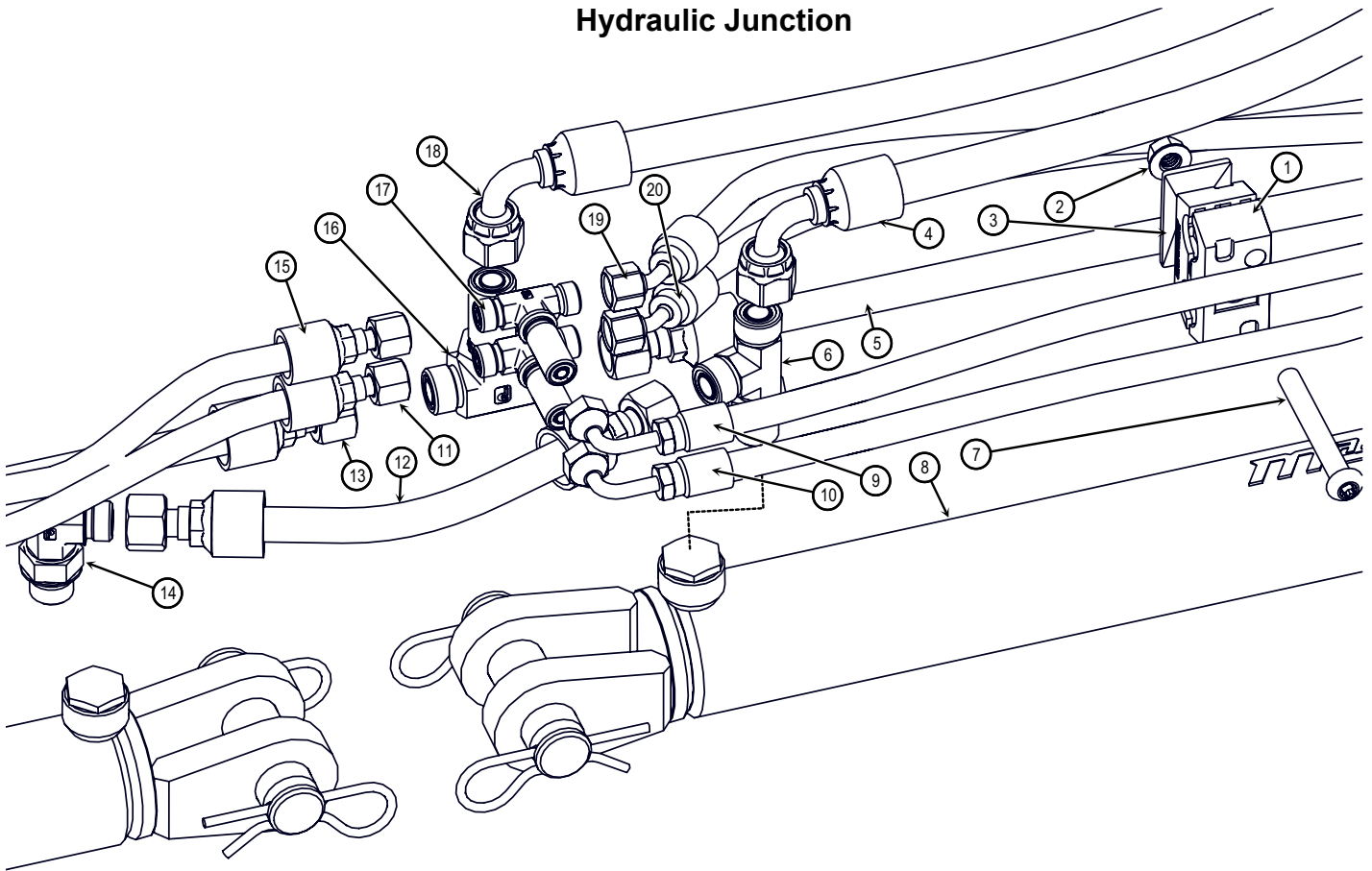

BOM ID	Part No.	Qty	Description
1	155531	1	.500 DIA
2	216.006	1	NUT,HX,FL,GR8 3/8-16
3	139231	1	CLAMP, COVER PLATE
4	1368531	1	100R17AR-06X58, -6 FORS STR X -8 FORS 90
5	1367651	1	100R17AR-06X27"; -6FORS STR x -8FORS STR
6	1007.08	1	STR, THD, RUN -8ORFS
7	257.006.048	1	SCREW,PHM,TX, 3/8-16 X 3
8	156086	2	CYLINDER, CLEVIS, 2" BORE, 1-1/4 ROD, 24"
9	1368461	1	100R17AR-04X60, -4 FORS STR X -4 FORS 90
10	1368451	1	100R17AR-04X63, -4 FORS STR X -4 FORS 90
11	1368501	1	100R17AR-04X80-1/2, -4 FORS STR X -4 FORS STR
12	1367641	1	100R17AR-06X9-1/2"; -6FORS STR x -8FORS STR
13	1367661	1	100R17AR-06X31-1/2"; -6FORS STR x -8FORS STR
14	1003.08.06	1	HA,90° -8MORB X -6MORFS
15	1368491	1	100R17AR-04X77-1/2, -4 FORS STR X -6 FORS STR
16	1015.08	1	HA,TEE,BKHD,BRA -8ORFS
17	1015.04	2	HA,TEE,BKHD,BRA -4ORFS
18	1368541	1	100R17AR-06X63-1/2, -6 FORS STR X -8 FORS 90
19	1368521	1	100R17AR-04X75, -4 FORS 45 X -4 FORS STR
20	1368511	1	100R17AR-04X73, -4 FORS 45 X -6 FORS STR

Cylinders

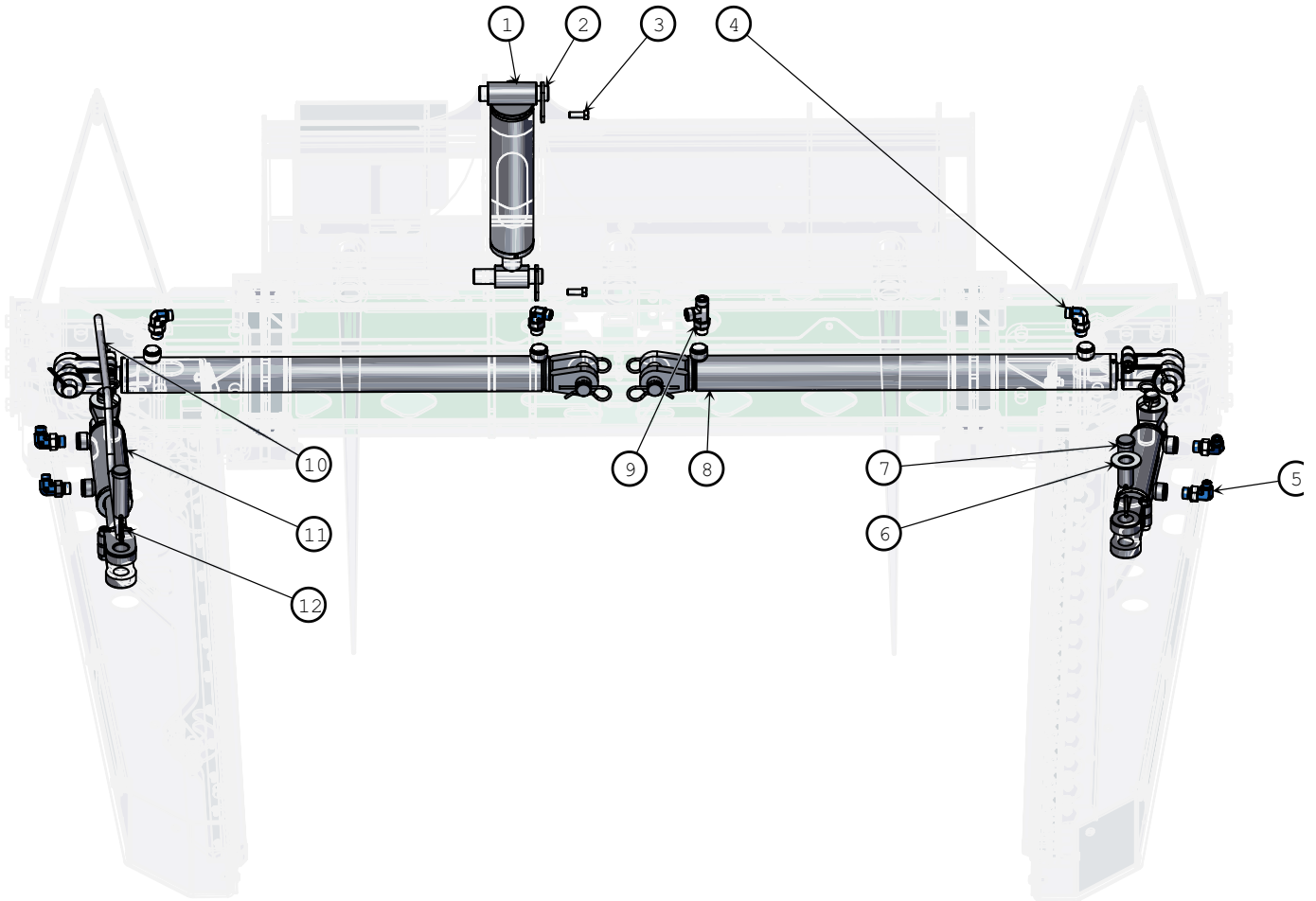

BOM ID	Part No.	Qty	Description
1	156239	1	CYLINDER, 2-1/2" BORE, 1-1/4" ROD, 8" STROKE, 16" CPC
2	1361752	2	PIN, ROTATE CYL
3	102.006.016	2	BOLT, HX, GR8 3/8-16X1
4	1003.08.06	5	HA,90° -8MORB X -6MORFS
5	1003.08.04	2	HA, 90° -8MORB X -4MORFS
6	133.016	3	WASHER,FLT,HARD 3/8
7	156261	6	PIN, CYLINDER, 1 OD X 2-15/16 LONG
8	156086	2	CYLINDER, CLEVIS, 2" BORE, 1-1/4 ROD, 24" STROKE, 34-1/4" CPC
9	1007.08	1	HA TEE STR, THD, RUN -8ORFS
10	1376951	1	KNIFE INDICATOR
11	156080	2	CYLINDER, 2" BORE, 1-1/4 ROD, 4" STROKE, 14-1/4" CPC
12	142.003	4	PIN,COTTER 3/16

Hydraulic Hose From-To Table		
Hose	From	To
1368451	MANIFOLD 1A	LOWER TEE BRANCH
1368461	MANIFOLD 1B	UPPER TEE BRANCH
1368471	MANIFOLD 2B	ROTATE CYLINDER ROD
1368481	MANIFOLD 2A	ROTATE CYLINDER BASE
1368491	LOWER TEE RIGHT BRANCH	KNIFE CYLINDER ROD
1368501	UPPER TEE RIGHT BRANCH	KNIFE CYLINDER BASE
1368511	LOWER TEE LEFT BRANCH	HOOK CYLINDER BASE
1368521	UPPER TEE LEFT BRANCH	HOOK CYLINDER ROD
1368531	MANIFOLD 3A	CLAMP CYLINDER BASE TEE
1368541	MANIFOLD 3B	CLAMP CYLINDER ROD TEE

Decals



156209

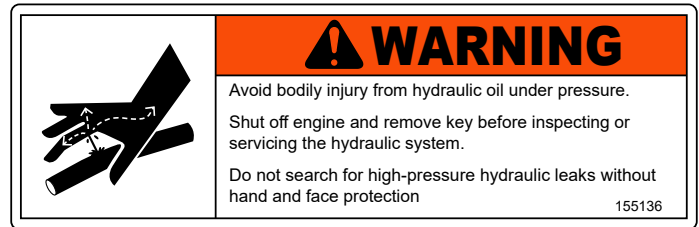

156210



156208



PART NO.	QTY.	DESCRIPTION
155136	1	DECAL, HYDRAULIC WARNING
155139	2	PINCH POINT DANGER
156008	2	DECAL, DANGER, WTR KNIFE
156088	1	DECAL, LOAD LIMIT
156089	2	DECAL, OPERATORS MANUAL
156047	1	WTR SWITCH BOX DECAL
156208	2	DECAL, HILLCO WTR
156209	2	DECAL, HILLCO WTR
1562010	1	DECAL, MADE IN AMERICA

Electrical

Part No.	Qty	Description
114.#10.008	4	SCREW,PHM,CH 10-24X1/2
119.#10	4	NUT,HX,FL,SERR 10-24
1366311	1	SWITCH BOX HARNESS
1366321	1	MANIFOLD HARNESS
1366341	1	SWITCH BOX TO VALVE, 30FT
1367451	1	SWITCH POWER
153851	1	RAM 2-7/16" X 1-5/16" BASE W/ 1" BALL
155265	1	SWITCH BOX
156001	1	SWITCH, ROCKER DPDT, ON-OFF-ON
156002	1	SWITCH ACTUATOR, BLACK W/ RED LENS
156084	1	RAM HANDLEBAR U-BOLT BASE,1/2" TO 1-1/4" DIA
156085	1	RAM COMPOSITE DOUBLE SOCKET SWIVEL ARM
EC-145021	1	CIRCUIT BREAKER-TYPE 1, 12VDC, 8AMP

Hydraulic Schematic

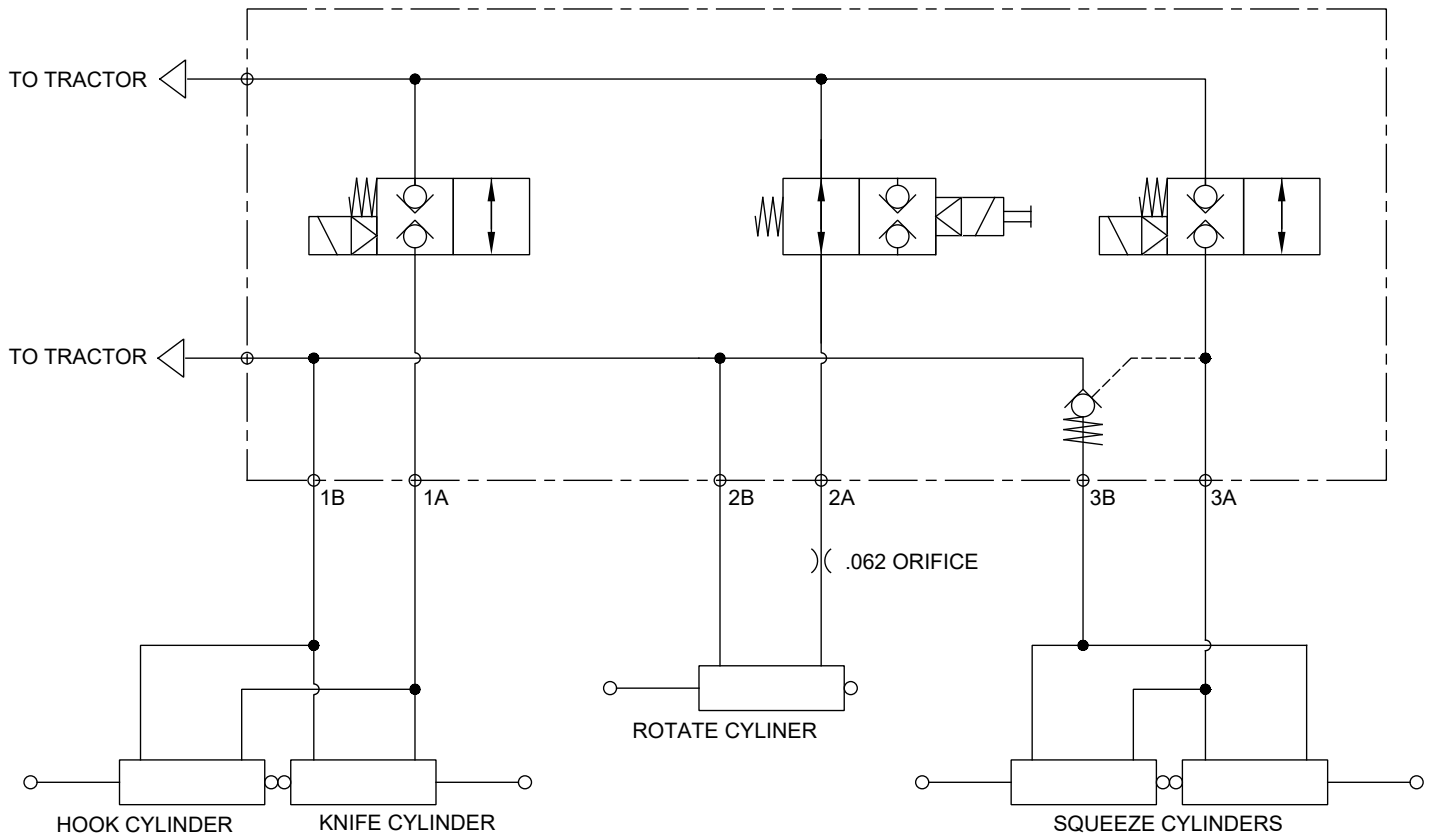

Electrical Schematic

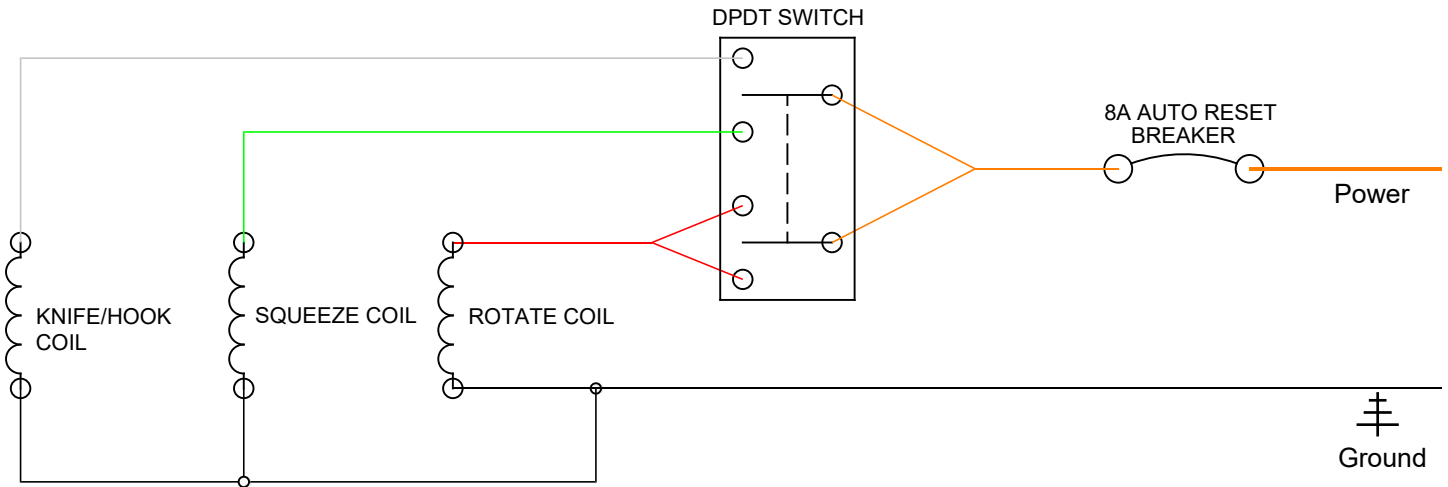

Electrical Theory of Operation

When the switch is in the Rotate position (B), no power is supplied to any of the coils at the hydraulic manifold. Valves #1 and #3 are normally closed and valve #2 is normally open. When the switch is moved to the Squeeze Position (A), 12V power goes to both the Green and Red wires. The Green wire opens valve port #1 and the Red wire closes valve port #2 diverting oil flow to the Squeeze cylinders. When the switch is moved to the Cut/Grab position (C), 12V power goes to both the White and Red wires. The White wire opens valve port #3 and the red wire closes valve port #2 causing hydraulic flow to go to the Cut/Grab cylinders.

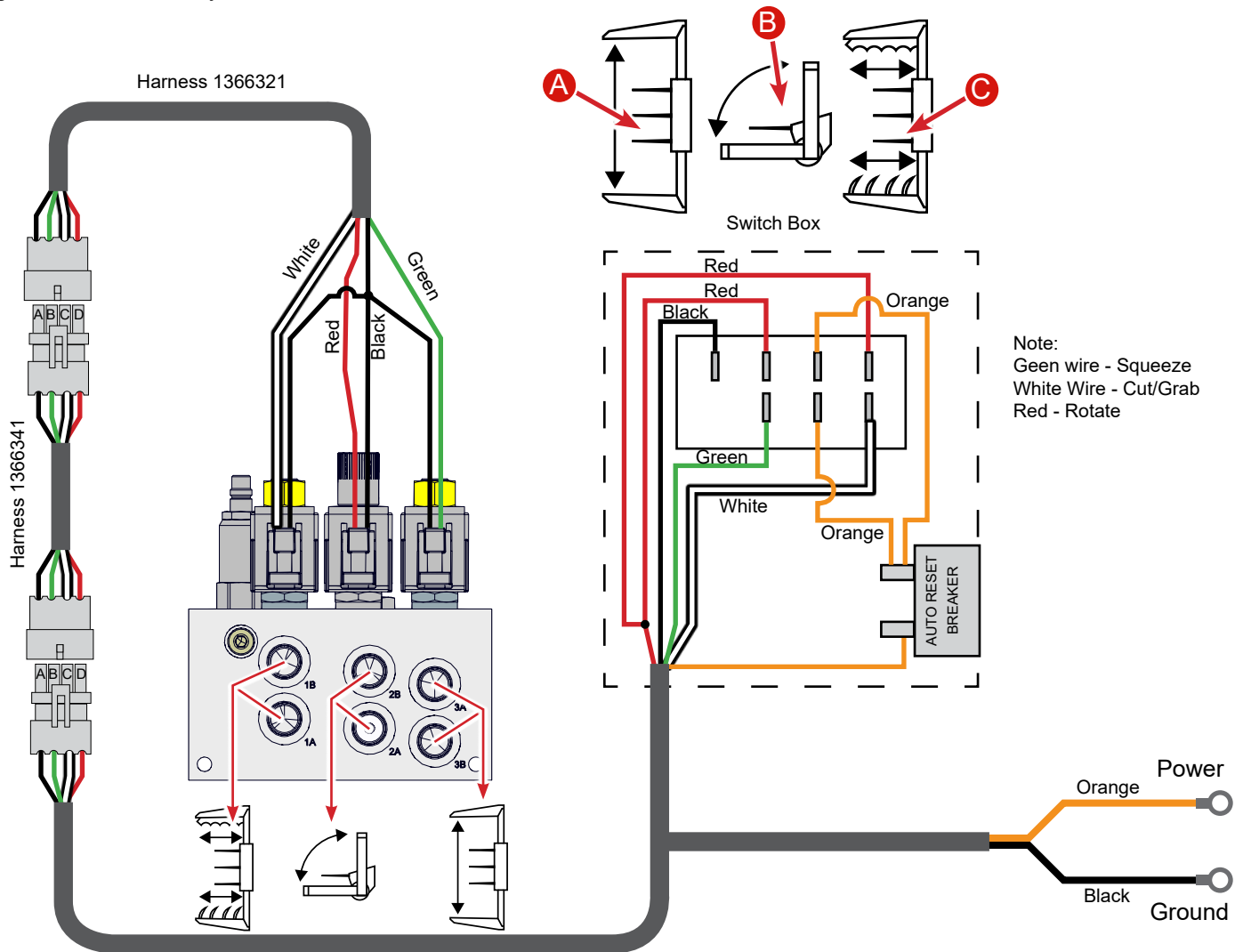

Trouble Shooting Guide		
Symptom	Probable Cause	Solution
Arms will not move in any switch position	Hydraulic oil is not being supplied to attachment	Check hydraulic connections between the attachment and tractor Check that tractor hydraulic system is functioning
Arms will not squeeze	No power to squeeze valve coil Hydraulic leak inside squeeze frame Debris in squeeze valve	Place switch into squeeze and check for 12v power on front coil (Green wire) Check all hoses for leaks or loose fittings Remove valve and inspect/clean
Attachment will not cut/grab	No power to cut valve on cut coil Hydraulic leak inside squeeze arms Debris in cut/grab valve	Place switch into squeeze and check for 12v power on rear coil (White wire) Check all hoses for leaks or loose fittings Remove valve and inspect/clean
Arms rotate in all switch positions	No power to switch box No power to rotate valve on cut coil Hydraulic leak between valve and rotate cylinder Plugged rotate orifice Debris in rotate valve	Check for power to switch box, lights on switches should light up in cut/grab and squeeze positions 8A breaker inside box is tripped, cycle key power to reset Place switch into cut or squeeze and check for 12v power on center coil (Red wire) Check all wiring for damaged or loose connections Check all hoses for leaks or loose fittings Remove orifice and inspect/clean Remove valve and inspect/clean
Edge hook will not deploy or retract with knife	Hook wedged inside arm Broken or loose strut	Remove front access panel and inspect mechanism for debris or obstruction Remove front access panel and inspect
Squeeze arms move slowly or chatter	Air in cylinders Debris in rotate valve	Lower loader to the ground and cycle squeeze arms fully several times Remove valve and inspect/clean
Hooks pull through netwrap	Netwrap is degraded over time	Adjust hooks outward to grab deeper into the bale
Hooks trap too much hay	Hooks are reaching excessively deep into bale	Adjust hooks inward to grab less hay
Knife stalls when cutting bale	Bale is wet/frozen Knife blade is dull or damaged	Reduce clamp force slightly Cycle knife additional times Replace blade (See maintenance section for proper procedure)
Hooks stall when cutting bale	Bent or damaged hook binding inside arm Hook actuator to hook bolts too tight	Replace damaged hooks (See maintenance section for proper procedure) Adjust tension on bolts (See maintenance section for proper procedure)
Knife misses outermost string on square bales	Twine is pulled tighter into bale than typical	Increase squeeze force Install shim washers between outermost knife cartridge bolts and knife arm frame

