



# Operator's Manual

(SN21001-21999)

**Model HC1010**  
Hillco Flex Harrow  
48', 60', 72' & 84'

D-170412CMA01C

## Table of Contents

Serial Number Tag	3
Safety Labels	3
Connecting to the Harrow	5
Disconnecting from the Harrow	5
Transport to Field Position	6
Field to Transport Position	8
Operation	9
Maintenance and Service	10
10 Hr Service	10
50 Hr Service	11
Annual Service	12
Tire Pressure	12
Center Frame	13
Adjustments	14
Push-Rod	14
Latch Mount	15
Latch Spring	16
Pull Pin	16
Hitch Height	17
Wing Wheel	17
Inspection Intervals	18
Bolt Torque	18
SAE Torque Chart	21

## Serial Number Tag

The serial number tag is located by the jack (A).

Write down your Serial Number here for future reference.

HC1010- \_\_\_\_\_

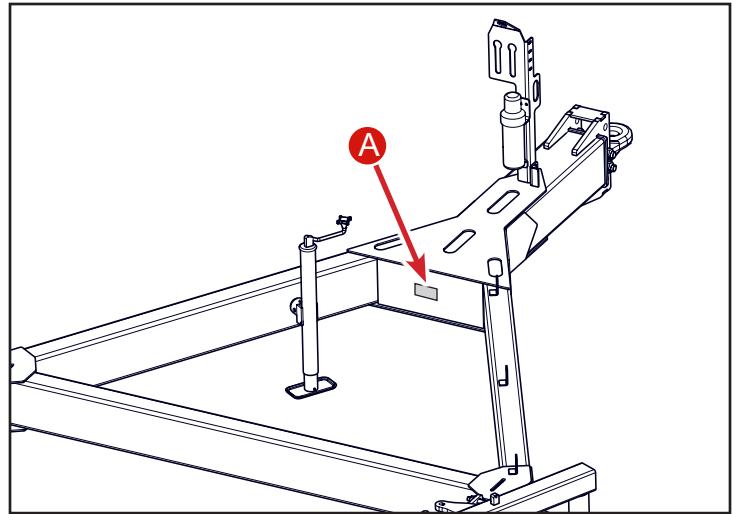

## Safety Labels

Familiarize yourself with the location of all safety labels. Read them carefully to understand the safe operation of your machine.

### READ OPERATOR'S MANUAL SYMBOL

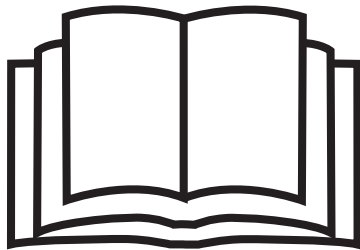

Decals, which display the Read Operator's Manual symbol, are intended to direct the operator to the Operator's Manual for further information regarding maintenance, adjustments and/or procedures for particular areas of the Leveling System. When a decal displays this symbol refer to the Operator's Manual for further instructions.

### TO APPLY NEW OR REPLACEMENT LABELS

1. Make sure the label area is smooth by removing any debris such as dirt or old labels.
2. Wash the area with soap and water and then dry it thoroughly.
3. After the area has completely dried, peel the backing off the safety label and place it onto the cleaned area.
4. Make sure all areas of the label have adhered to the machine by pressing down on the entire face of the label, including the corners.

**! WARNING**

**IMPLEMENT CONTROL HAZARD**

1. Do not tow at speeds over 20 mph.
2. The towing vehicle must weigh at least 2/3 the weight of this implement. Refer to Operator's Manual for more information.

**FAILURE TO FOLLOW THESE INSTRUCTIONS COULD RESULT IN SERIOUS INJURY OR DEATH**

155678



**! WARNING**

**SAFETY STOP ON LIFT CYLINDERS**

1. USE SAFETY STOPS ON LIFT CYLINDERS (A) WHEN IN TRANSPORT MODE.
2. STORE SAFETY STOPS ON SWING ARMS (B) WHEN IN FIELD MODE.

**FAILURE TO FOLLOW THESE INSTRUCTIONS COULD RESULT IN SERIOUS INJURY OR DEATH**

155681



**! WARNING**

**SAFETY STOP ON WING CYLINDERS**

1. USE SAFETY STOPS ON WING CYLINDERS (A) WHEN IN TRANSPORT MODE.
2. STORE SAFETY STOPS ON WHEEL PIVOT MOUNT (B) WHEN IN FIELD MODE.

**FAILURE TO FOLLOW THESE INSTRUCTIONS COULD RESULT IN SERIOUS INJURY OR DEATH**

155682



## Connecting to the Harrow

1. Before connecting the harrow cart to the tractor, raise or lower the jack to the proper height.
2. Back the tractor to the tongue and install the hitch pin. Note: Be sure to use a high strength, appropriately sized hitch pin with a mechanical retainer.
3. Connect the safety chain to the drawbar support or the frame of the tractor or tow vehicle.
4. Connect the hydraulic hoses to the tractor. Note: The ½” hoses connect to the lift cylinders and the ¼” hoses connect to the wing cylinders.
5. Lower the jack, remove the pin and rotate it out of the way and reinstall the pin.

## Disconnecting from the Harrow

1. Disconnect from the harrow on a hard level surface. If on a incline, it may be necessary to place blocking in front and behind the tires.
2. Make sure that all safety stops are in place on the lift and the wing cylinders.
3. Remove the pin and rotate the jack down and reinstall the pin.
4. Remove the hydraulic hoses and stow them in the hose hanger.
5. Remove the safety chain and the hitch pin.



# IMPORTANT

Do not park the harrow on a steep incline with the harrow in the field position. It is possible that the center of gravity may be such that there is no tongue weight allowing the back of the harrow to sit on the ground. This will result in the tongue lifting upward.

## Transport to Field Position

1. Remove the safety stops from the wing cylinders (A) and pin them to the tab (B).
2. Remove the safety stop from the pins above the lift cylinders (C) and pin them to the top of the swing arms (D).

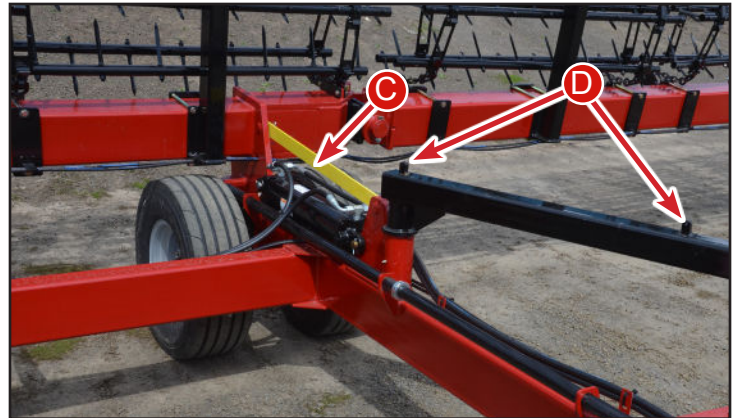
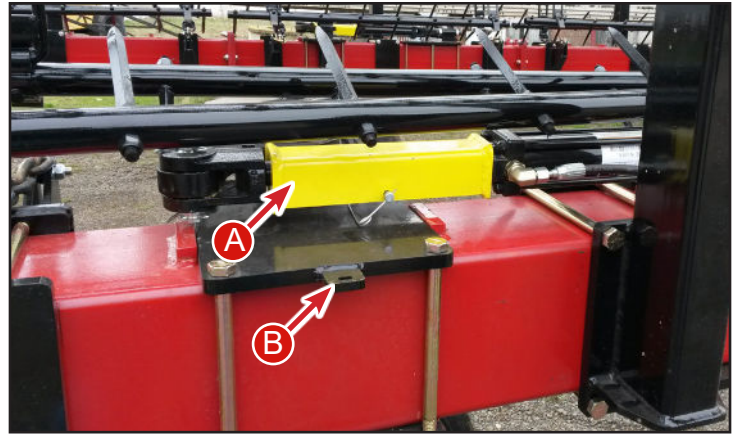

3. Rotate the wing wheels to approximately 45°.
4. Slowly back up until the pull arm pin makes contact with the latching pocket. As you back up, be sure the wings open evenly.
5. After the pull arms pins have made contact with the latching pocket, finish rotating the wing wheels so they are pointed the same direction as the cart tires (F).



6. Rotate the harrows rearward until the lock arm fully engages the pin (A) and locks into place. **IMPORTANT!** Be sure to visually check that the lock arm has fully engaged the pull arm pin before driving forward.
7. Drive forward slowly and lower the harrow into the field position.

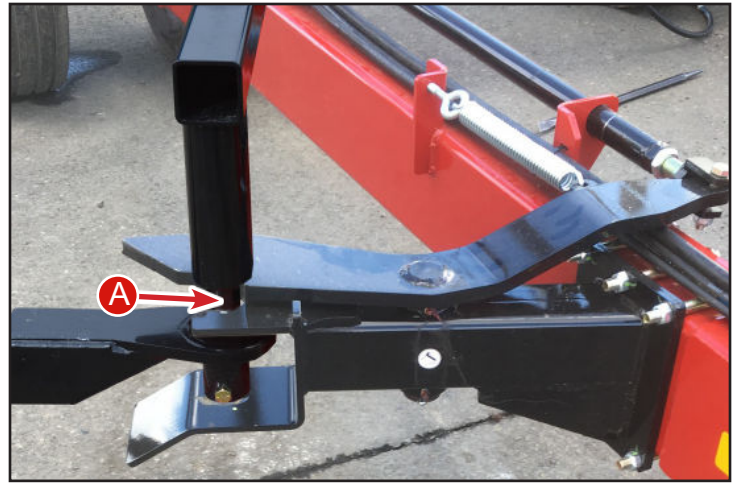

## Field to Transport Position

1. Rotate the harrows to the upright position until the cylinders bottom out.
2. Rotate the wing wheels so they are parallel with the wing beams.
3. Slowly drive the unit forward until the wings are straight back behind the cart.
4. Install the safety stop to the pins above the left lift cylinders and pin into place (A).
5. Install the safety stops on the wing cylinder and pin into place (B).
6. Inspect the two center sections and the sections closest to the hinge to make sure that they are lying properly so the harrow sections won't bind when turning corners.

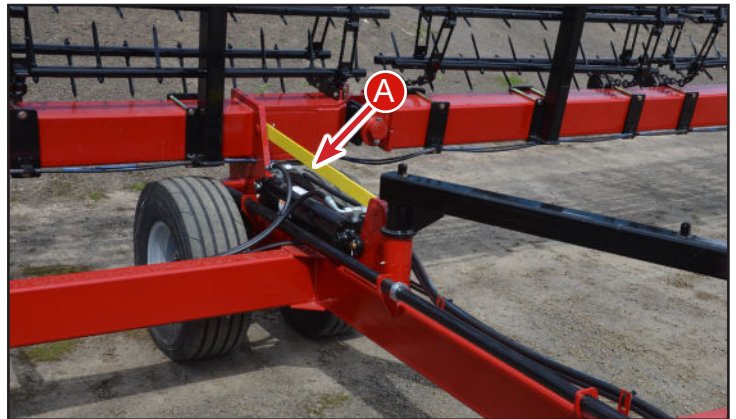



## Operation

For best results operate the harrow at speeds 6-9 mph.

### NOTE

To prevent damage when going through draws and ditches, we recommend running the harrow in float mode.

When turning corners do not turn too short such that the harrows start to bunch up on the inside sections or if the inside wing starts to go backwards. This will cause damage to either the harrow or the cart. If you get in a situation like this you can lift the harrow up to where the back section of the harrow is off the ground. **Do not lift the harrow further than that otherwise the pull arms will unlatch and the wings will fold back.**

Center of the turning radius is at the edge of the wing. Not the wing wheels. If you pivot around the wing wheels damage will occur.

Center of Turning Radius →

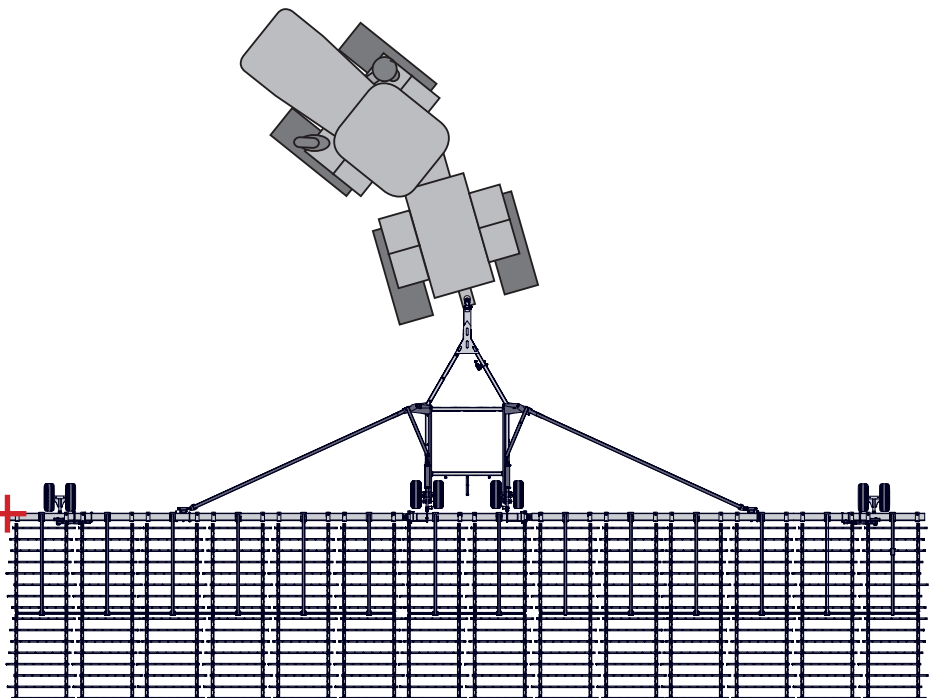

## Maintenance and Service Schedule

Prior to each use, check for loose bolts and replace lost or worn parts.

### 10 Hour Service

Zerks on left side shown. Repeat for right side.

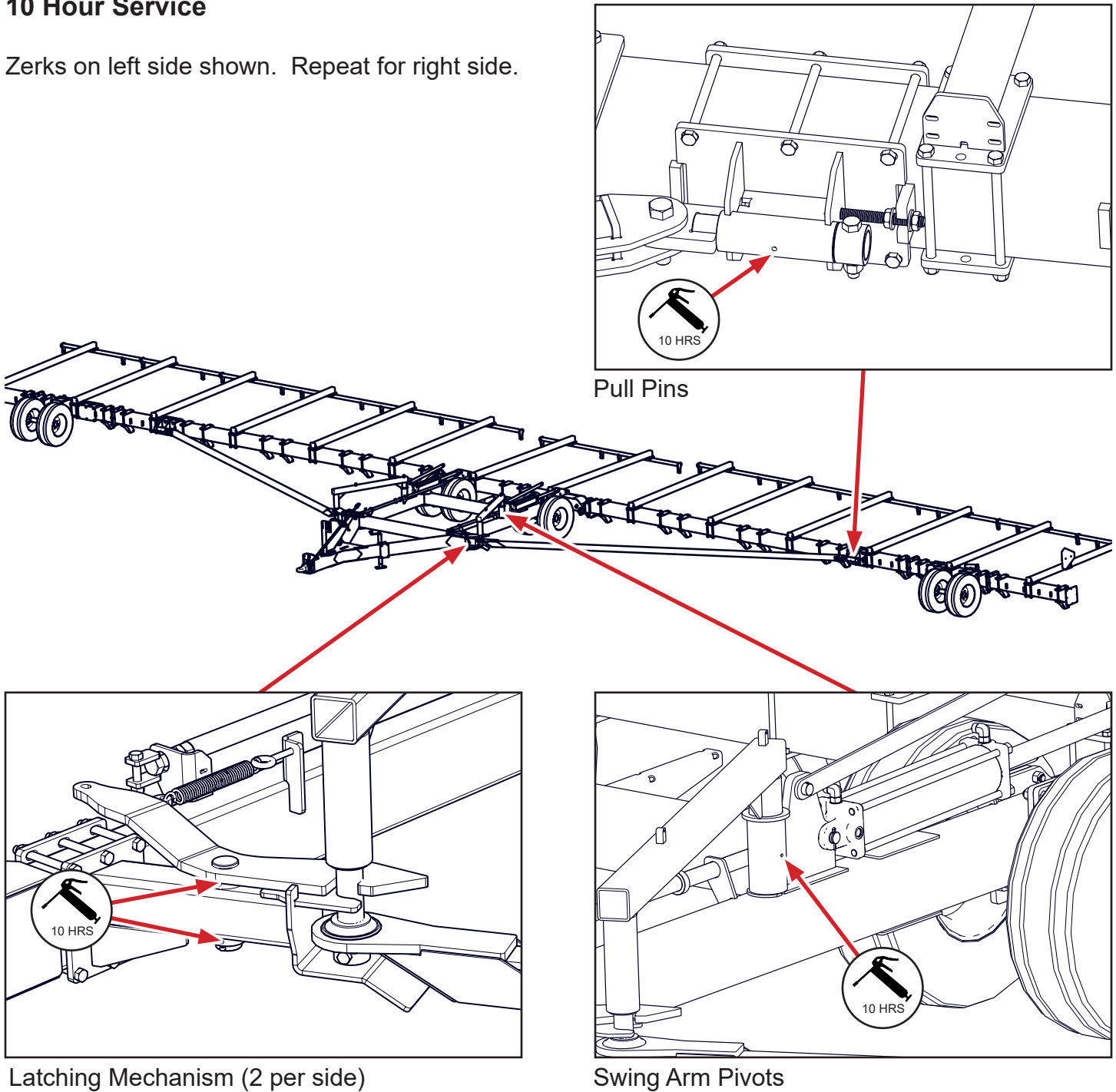

## 50 Hour Service

Zerks on left side shown. Repeat for right side.

Wing Wheel Pivots (1 per side)

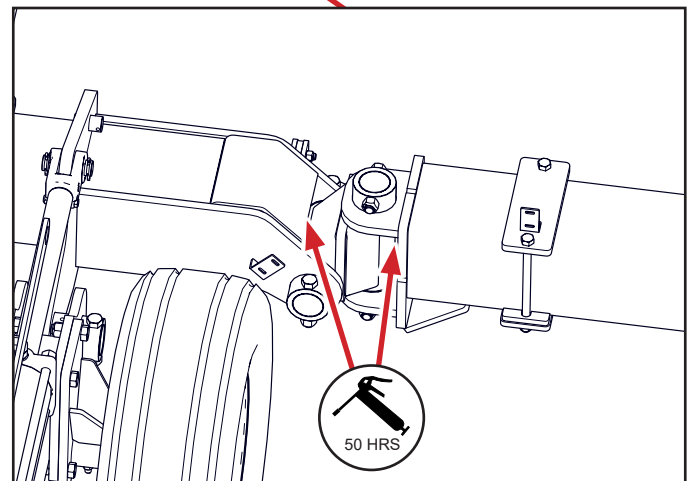
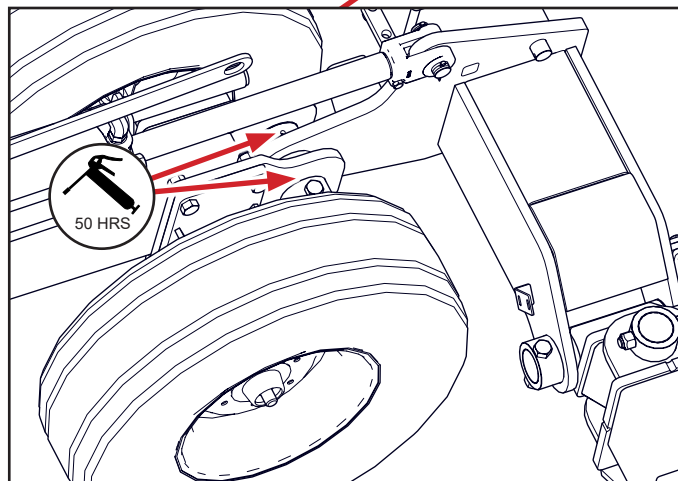
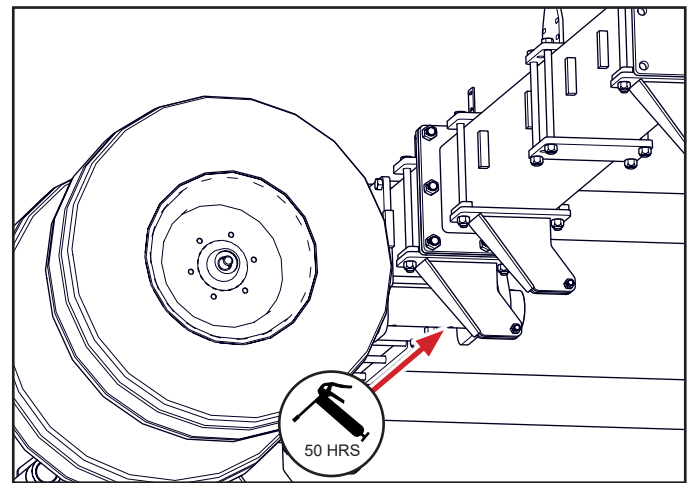
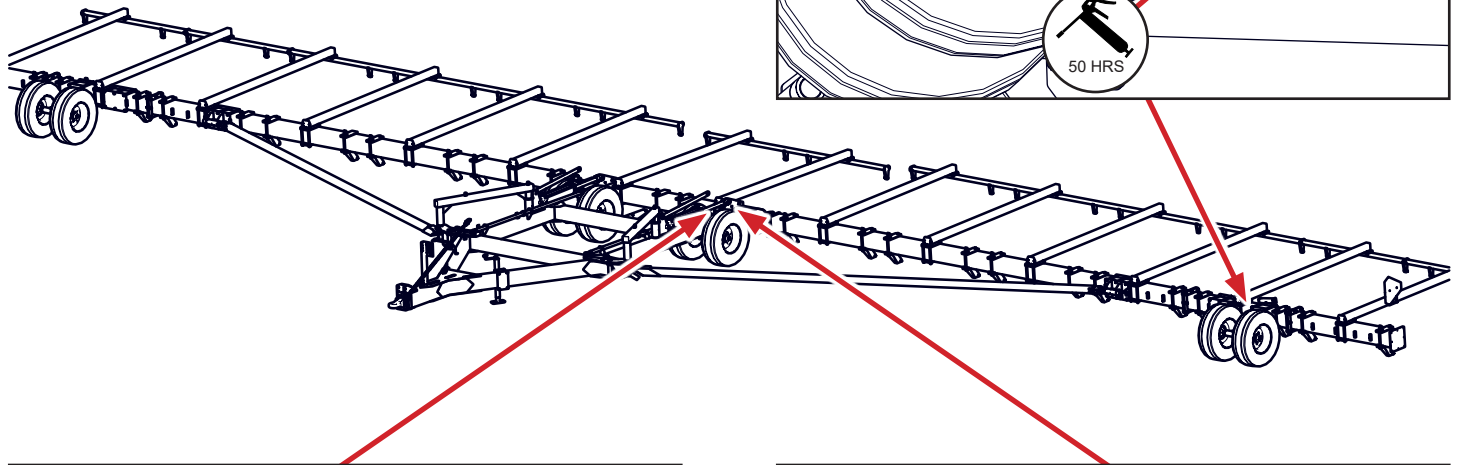

Center Section Cylinder Mounts (2 per side)  
Access to these zerks is easiest in field position.

Wing Pivots (2 per side)

## Annual Service

The hubs are equipped with a grease fitting and it is up to the operator whether or not these are used. Do not over-grease the hubs or damage may occur to the seals.

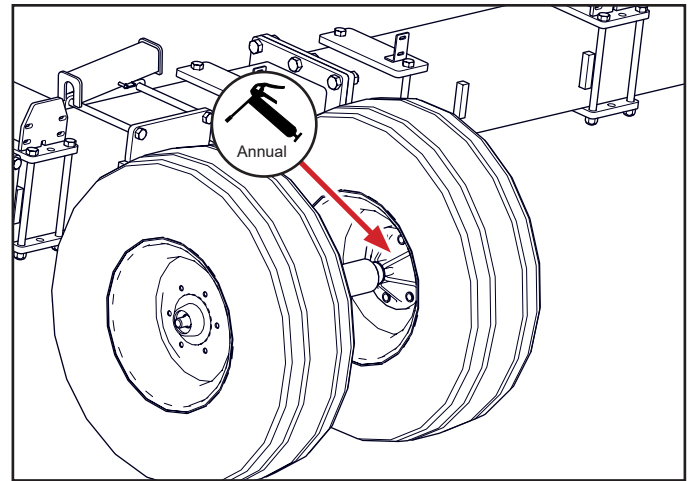

Wheel bearings

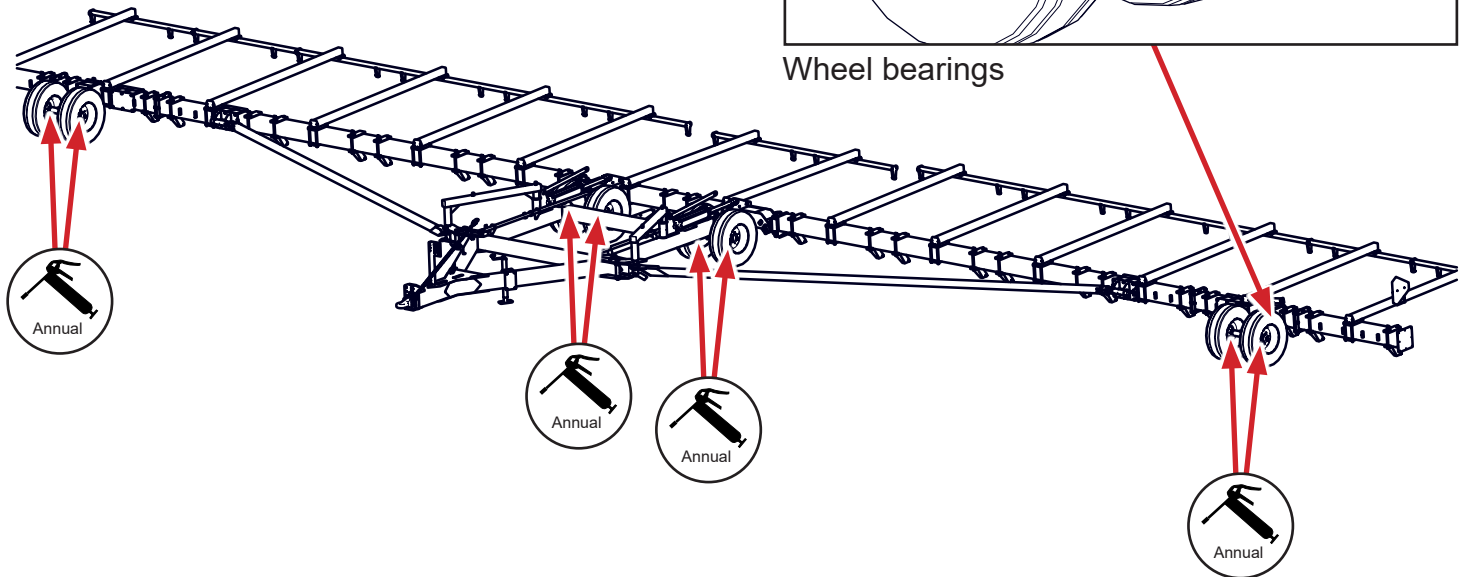

## Tire Pressure (Firestone AD2 IF280/70R15)

- Recommended Minimum Tire Pressure - 45 PSI
- Maximum Tire Pressure - 64 PSI (4680 LB Load Rating @ 40 MPH Maximum Speed)

## Tire Pressure (11L-15 IL 12-ply)

- Recommended Minimum Tire Pressure - 45 PSI
- Maximum Tire Pressure - 52 PSI (3,200 LB Load Rating @ 30 MPH Maximum Speed)



## Center Frame

The center frame is built to support a tank or Valmar.

If the cart is equipped with the Firestone IF280/70R15 tires the limiting load carrying capacity is the spindle. Each spindle is rated for 4,570 lbs. The gross weight allowed on the center 4 tires is 18,280 for carts with dual center wheels. On carts with single center tires the max gross weight is 9,140 lbs.

If the cart is equipped with 11L15 12 ply tires the the limiting load carrying capacity is the tire. Each tire has a load rating of 3,200 lbs per tire at 52 psi. The gross weight allowed on the center 4 tires is 12,800 for carts with dual center wheels. On carts with single center tires the max gross weight is 6,400 lbs.



## Adjustments

### Push-rod Adjustment

This adjustment is necessary if cart latch does not easily unlock when switching from field to road mode.

It is easiest to make this adjustment with the cart in road transport. Make sure cart wheels are blocked.

Use a jack to lift the pull arm so that the bearing is off the collar. Disconnect the pull arm from the support arm by removing the bottom bolt and collar (A). Lower the jack to slide the pull arm off of the support arm.

Pivot the Support Arm towards the latch so that it can be swung into the latch mount and latch plate by hand.

Loosen the jam nut (B) on the clevis end of the pushrod.

Adjust the pushrod until the latch plate clears the pin by about 1/16" (C).

Retighten the jam nut. Reconnect support arm to pull arm and reinstall collar and bolt.

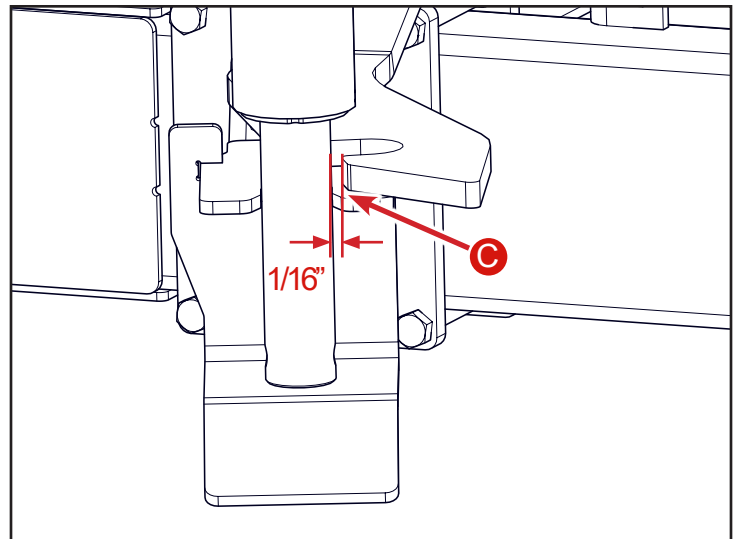
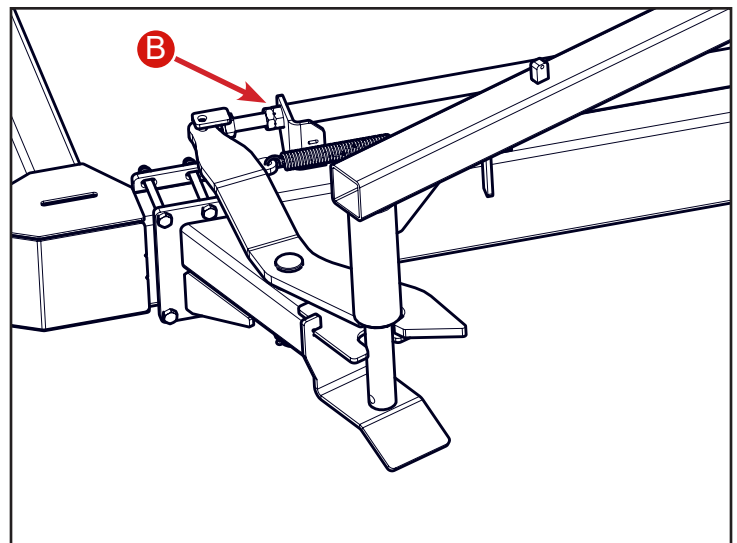
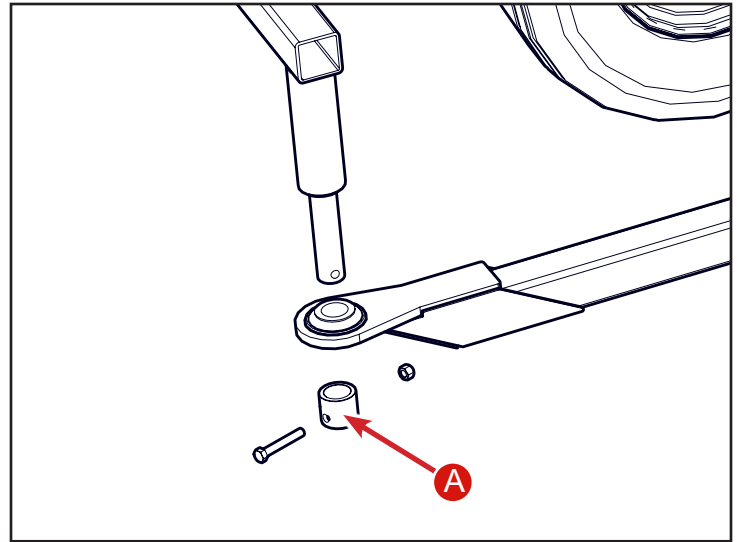

## Latch Mount Adjustment

This adjustment is necessary if the support arm (A) does not align with the latch mount (B).

It is easiest to make this adjustment with the cart in road transport. Make sure cart wheels are blocked.

Use a jack to lift the pull arm so that the bearing is off the collar. Disconnect the pull arm from the support arm by removing the bottom bolt and collar (C). Lower the jack to slide the pull arm off of the support arm.

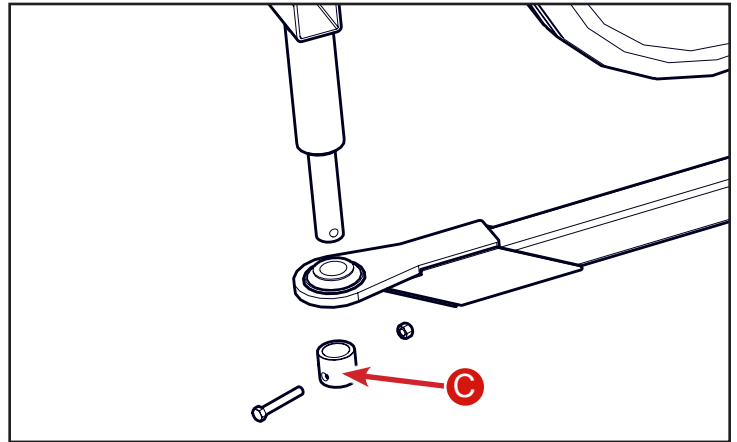
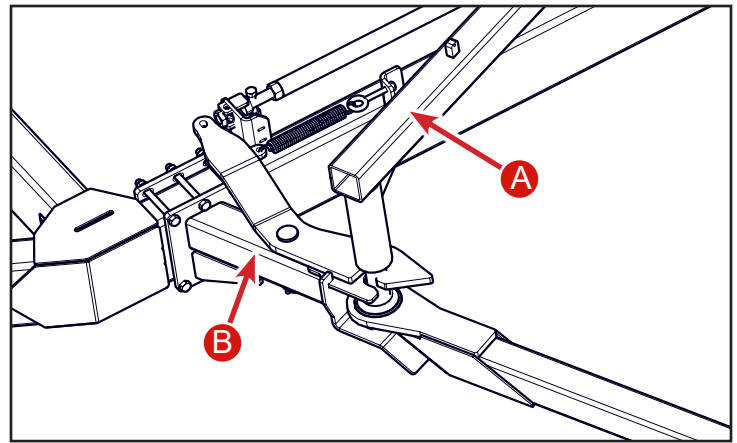

Loosen & remove the eyebolt (D) and pull spring (E).

Loosen the (6) mounting bolts (F) for the latch mount

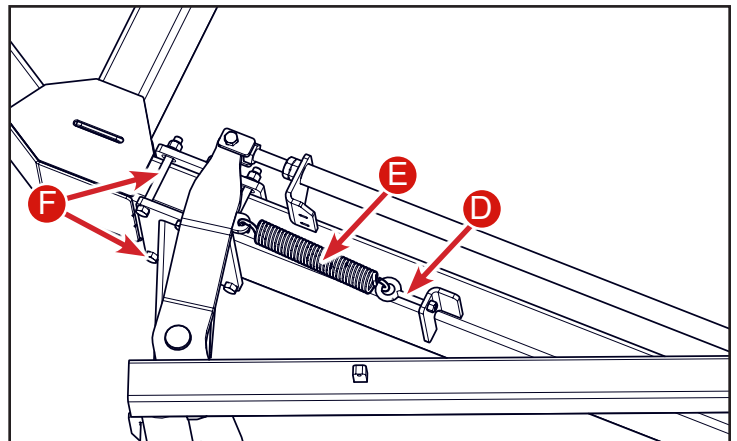

Rotate the swing arm into the latch mount cradle, adjusting the mount fore or aft until the pin on the swing arm (G) seats into the cradle

Tighten the (6) latch mount bolts  
Reinstall the pull arm to the swing arm  
Reinstall the pull spring & eyebolt

Reconnect support arm to pull arm and reinstall collar and bolt.

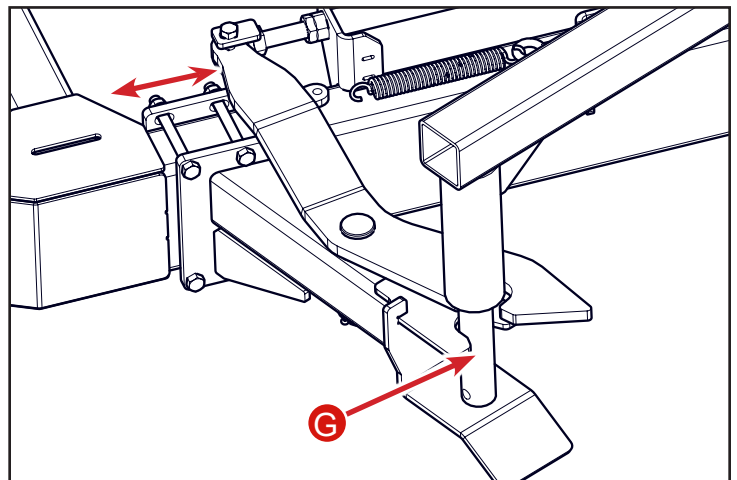

## Latch Spring Adjustment

Adjust nut (A) so there is 7/8" from the mounting plate to the end of the eyebolt. If more tension is desired, tightening the nut increases tension.

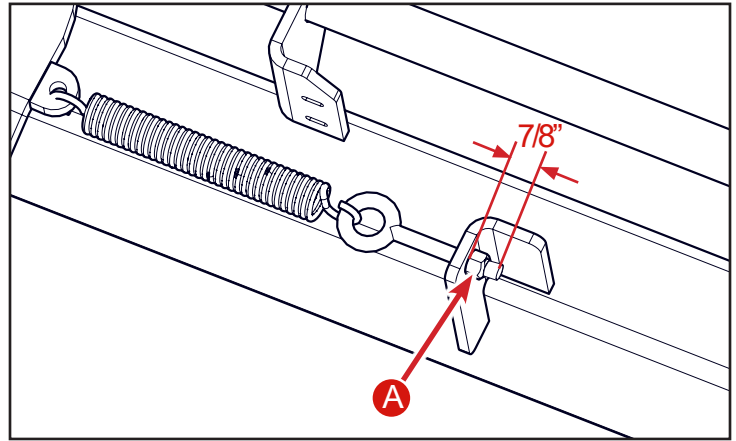

## Pull Pin Adjustment

If a wing tube (B) is not parallel to the center tube (C) then the pull pins can be adjusted to make the tubes parallel.

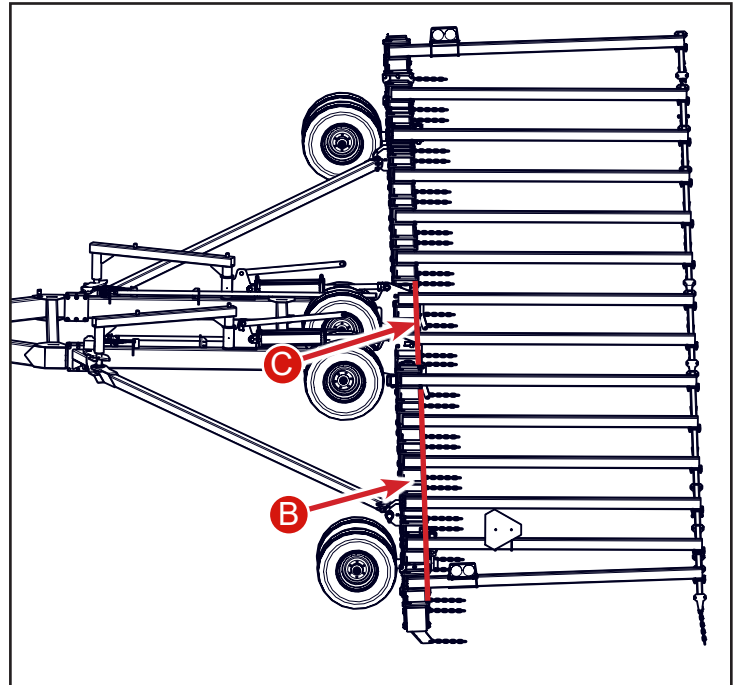

Make sure the harrow sections are on the ground.

Remove bolt connecting pull arm to pin. (D)

Remove Pull Arm (E).

Remove collar and bolt from pin (F).

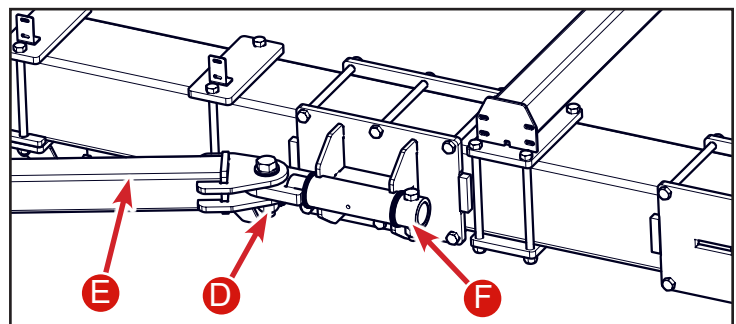

To bring the wing back move bushings from the outside (H) to the inside (G). To move the wing forward move bushings from the inside (G) to the outside (H).

Reinstall pin, collar and retaining bolt. Reinstall pull arm.

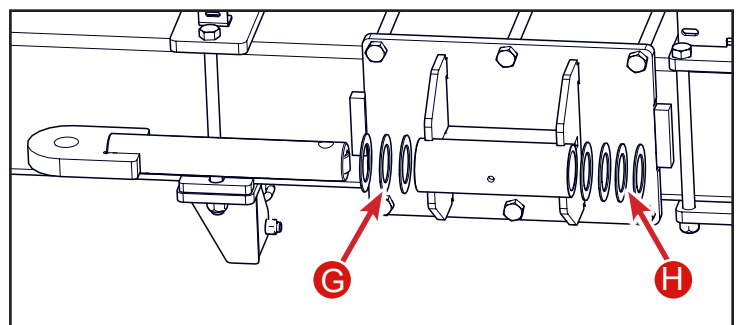



## Hitch Adjustment

Adjust the hitch so that when it is coupled to the tractor drawbar, the cart frame sits level with the ground.

Uncouple the hitch from the tractor.

Remove the 1-inch bolt (A) that retains the safety chain and remove.

Remove the (2) 1-inch bolts (B) that retain the draw ring to the cart frame

Raising the hitch one set of holes makes a 2-1/2" change in height

Move the hitch to the desired set of holes and reinstall the 1-inch bolts.

Retorque the draw ring bolts to 150 lb/ft

Move the safety chain to an empty hole and retorque.

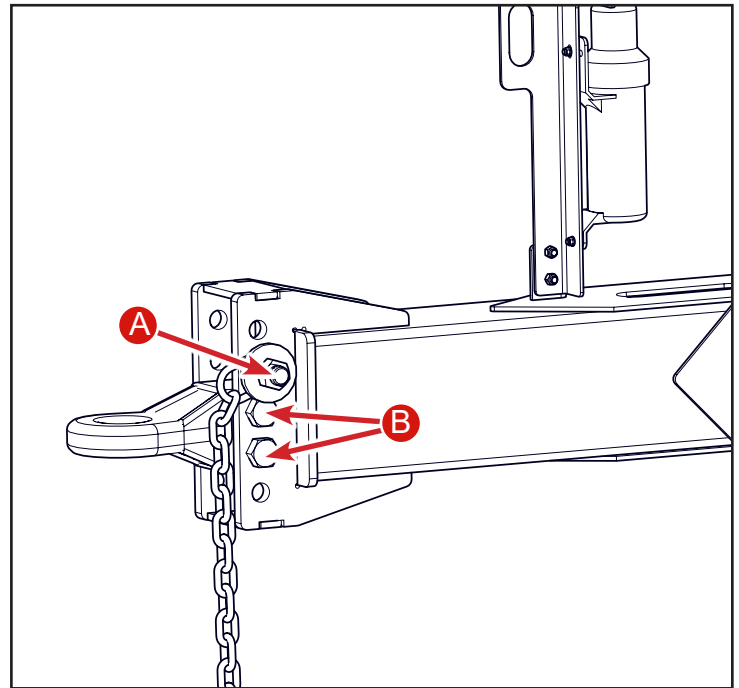

## Wing Wheel Adjustment

With the 1/4" hydraulic hoses connected to a tractor, actuate the wing wheel cylinders until fully compressed

Place a straight edge across the face of the wing tires (A)

Use a 1" end wrench to hold the base mount (C).

Use a 1-7/8" end wrench to loosen the jam nuts (D).

Adjust the wing wheel base cylinder mount until the straight edge is parallel to the wing tube (B)

Retighten the jam nuts.

This process can also be done with the harrow in the field position.

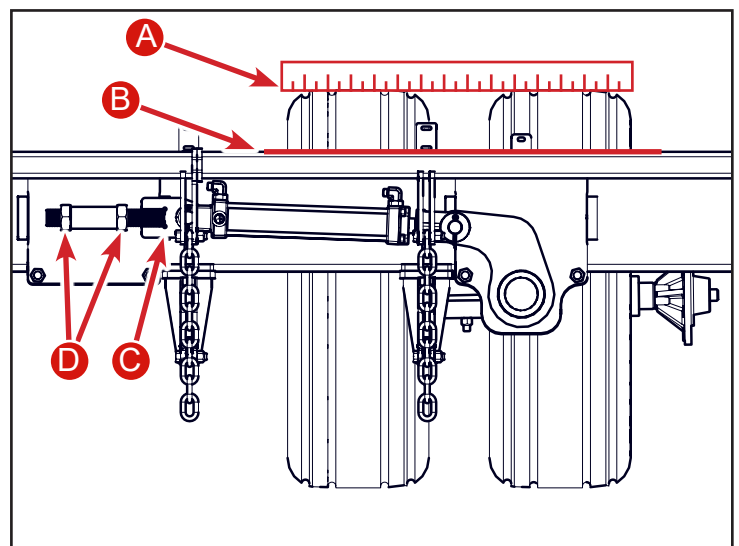

## Inspection Intervals

### After 1st Day of Use

Perform a visual inspection of all of the mounting hardware on the cart and harrow sections checking for loose or missing fasteners

If any loose fasteners are found, torque to the specifications as outlined under the bolt torque section.

### After 1st Week of Use

Perform a thorough inspection of the harrow sections looking for loose or missing fasteners. Torque all fasteners covered in the Bolt Torque section on pages 17-19 after first week.

### Before Each Season

Perform a visual inspection of all of the mounting hardware on the cart and harrow sections checking for loose or missing fasteners.

## Bolt Torque

(Torque All Bolts to the Value Shown in the Chart for a Grade 5 or Grade 8 bolt with a Dry Thread)

The following bolts are torqued to special specifications because of the application in which they are used:

Lift Arm Mounting Bolts (5/8-inch) = 110 lb-ft. (A)

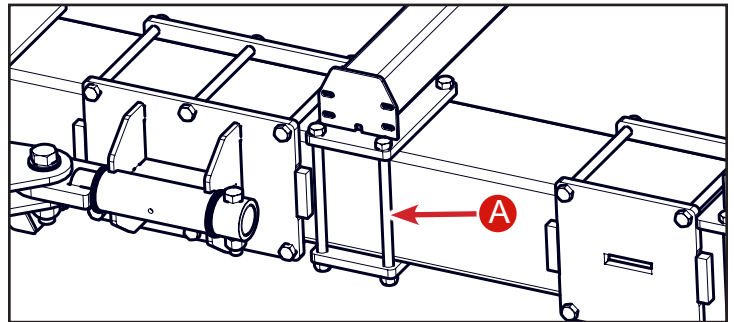

Harrow Pull Mounting Bolts (5/8-inch) = 120 lb-ft (B)

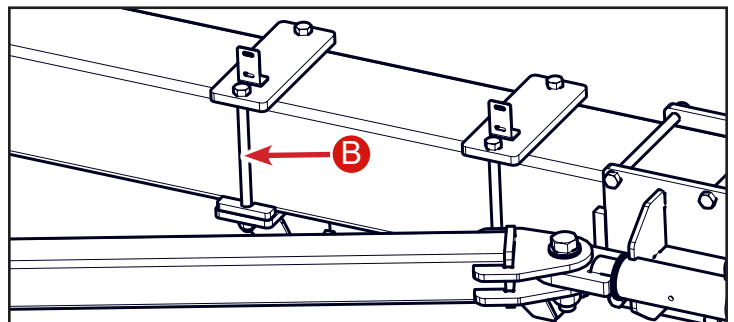

Axle Pivot Mounting Bolts (5/8-inch) = 120 lb-ft (A)

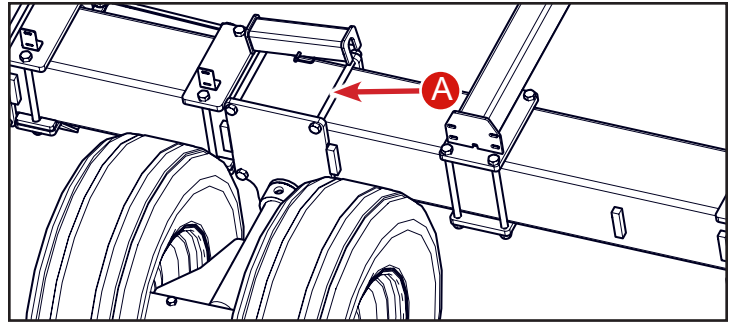

Harrow Spike Nuts (1/2-inch) = 30-32 lb-ft. (B)

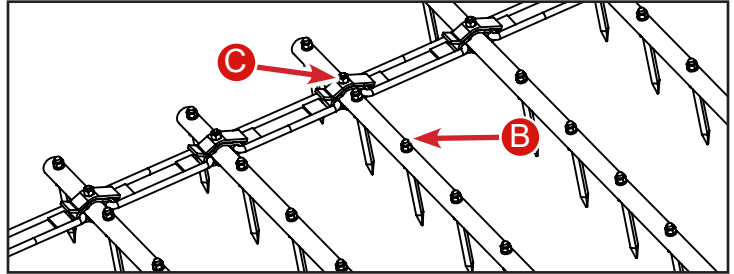

Bar Clamp Bolts (1/2-inch) = 60 lb-ft. (C)

Lift & Pull Chains on Cart End (1/2-inch) (D)  
Tighten until the bolt just begins to deflect the plates (Chain Must Be Able to Swivel)

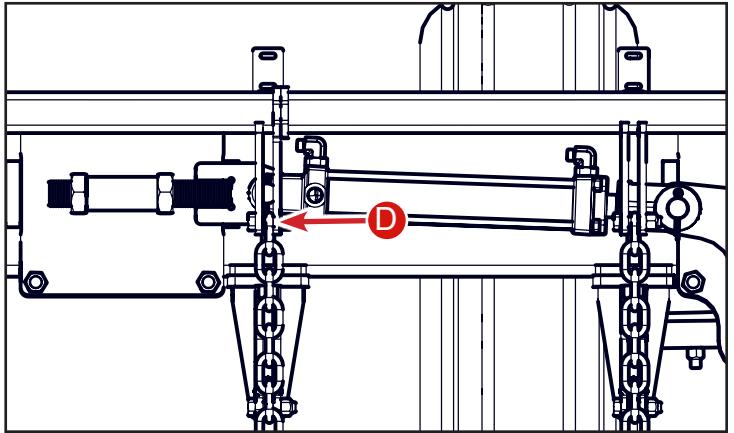

Draw Ring Bolts (1-inch) = 150 lb-ft. (E)

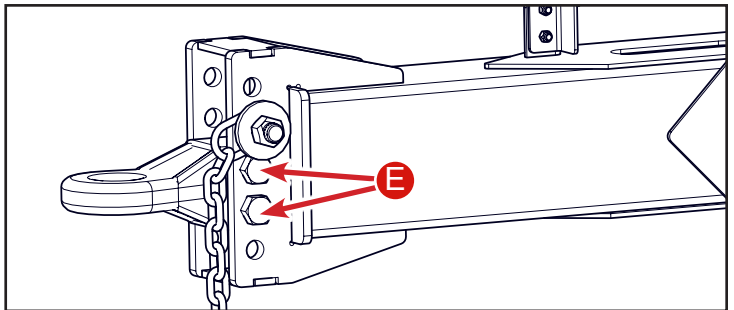

- Pull Pin Bolts (1-inch) = Tighten until the bolt just begins to deflect the plates. (F)

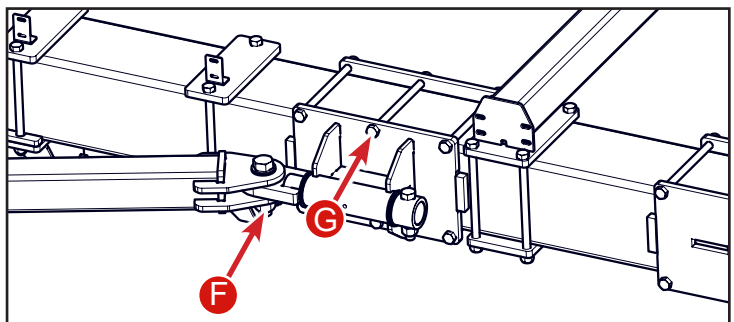

Pull Pin Mounting Bolts (5/8-inch) = 120 lb-ft. (G)

Wing Cylinder Base Mount Bolts (5/8-inch) = 120 lb-ft. (A)

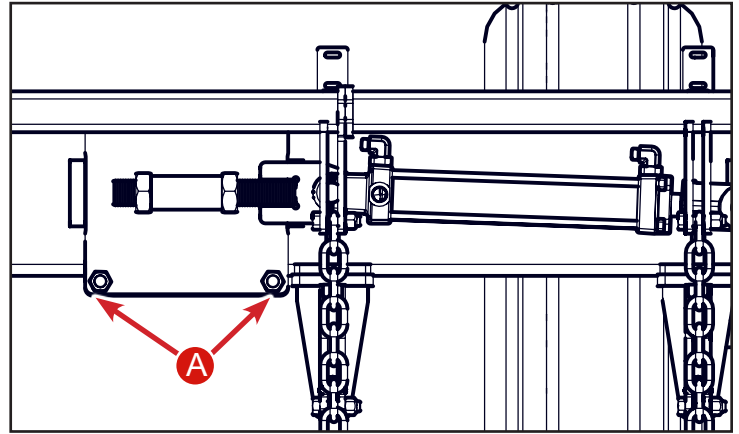

Pushrod Clevis Bolts (5/8-inch) (B)  
Tighten until the bolt just begins to deflect the plates.

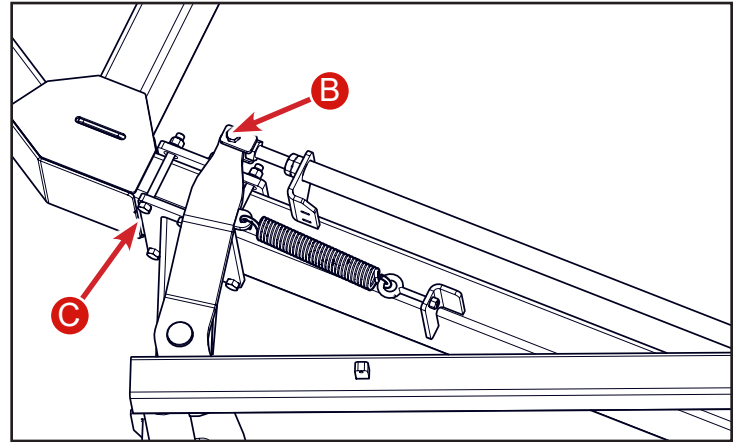

Latch Mount Bolts (5/8-inch) = 150 lb-ft (C)

## Unified Inch Bolt and Cap Screw Torque Values

SAE Grade and Head Markings		
SAE Grade and Nut Markings		

SIZE	Grade 5, 5.1, or 5.2				Grade 8 or 8.2			
	Lubricated(1)		Dry(2)		Lubricated(1)		Dry(2)	
	N*m	lb-ft	N*m	lb-ft	N*m	lb-ft	N*m	lb-ft
1/4	9.5	7	12	9	13.5	10	17	12.5
5/16	20	15	25	18	28	21	35	26
3/8	35	26	44	33	50	36	63	46
7/16	55	41	70	52	80	58	100	75
1/2	85	63	110	80	120	90	150	115
9/16	125	90	155	115	175	130	225	160
5/8	170	125	215	160	240	175	300	225
3/4	300	225	375	280	425	310	550	400
7/8	490	360	625	450	700	500	875	650
1	725	540	925	675	1050	750	1300	975
1-1/8	900	675	1150	850	1450	1075	1850	1350
1-1/4	1300	950	1650	1200	2050	1500	2600	1950
1-3/8	1750	1250	2150	1550	2700	2000	3400	2550
1-1/2	2250	1650	2850	2100	3600	2650	4550	3350

(1) "Lubricated" Means coated with a lubricant such as engine oil, or fasteners with phosphate and oil coatings.

(2) "Dry" means plain or zinc plated without any lubrication.

