

Model CH7010 Hillco Leveling System
For Serial Numbers CH7010-12001 thru CH7010-12999



Model CH7010 Sidehill Leveling System Parts Manual

SN CH7010-12001 thru CH7010-12999

For Case IH 5130, 6130,
and 7130 Combines

D-120624CMA01A

Table of Contents

General Information	2
Serial Number Location	2
Text and Illustrations	2
Abbreviations	2
Right and left Identification	2
Part Orders	2
Transition	3
Transition Fasteners	5
Radial Pin Slip Clutch	7
Carriage	8
Carriage Fasteners	10
Drop Axle	12
Ladder	13
Electrical	15
Electrical Connectors and Cables	17
Hydraulics	19
Code 62 Adapters	20
Hydraulic Manifold	22
Hydraulic Hoses	24
Hydraulic Adapters	25
Miscellaneous	26

Model CH7010 Hillco Leveling System
For Serial Numbers CH7010-12001 thru CH7010-12999

Hillco Technologies, Inc.
107 1st Avenue
Nezperce, Idaho 83543

Phone	800-937-2461
	208-937-2461
Fax	208-937-2280

www.hillcotechnologies.com
email: support@hillcotechnologies.com

General Information

Serial Number Location

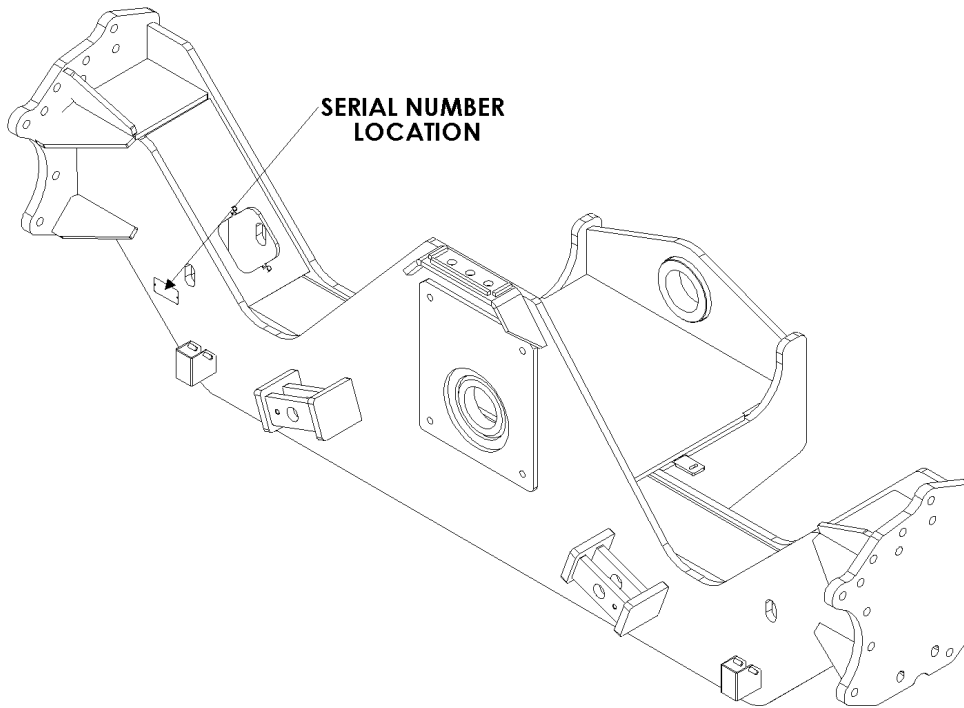

Text and Illustrations

The arrangement of this parts catalog is for easy identification of parts. All parts are illustrated in exploded views in proper relation to each other. Some diagrams refer to other pages for further information. Reference numbers used in the illustrations refer to line numbers in the part lists. The part lists appear to the right or below all diagrams and correspond with those diagrams. Included in the part lists, along with the reference numbers are part numbers, part descriptions and the quantity of the part required per leveling system.

Abbreviations

SN “Serial Number” refers to the serial number given to each leveling system (by Hillco Technologies), as well as the serial number given to the combine (by the specific combine manufacturer) the leveling system is installed. See above for the leveling system’s serial number location. This abbreviation is used interchangeably in both instances. Each Model CH7010 Leveling System uses the following serial number format: CH7010-XXXX (sequential numbers).

ASM “Assembly” refers to a whole grouping of parts (shown in the diagram corresponding with the page where “ASM” is shown unless otherwise noted). Some assemblies have parts that are sold separately, however some must be purchased as a single unit. Hillco Product Specialists will be able to assist you with any questions.

NS “Not Shown” refers to a part that is not depicted in the illustration.

Right and left Identification

The reference to right-hand and left-hand in this catalog is identified by the operator sitting in the operator’s seat, looking toward the front of the machine (in normal forward travel).

Part Orders

Orders must specify product model, serial number, correct part number, complete description, quantity required, method of shipment, shipping address, and billing address.

Transition With Header Adapter

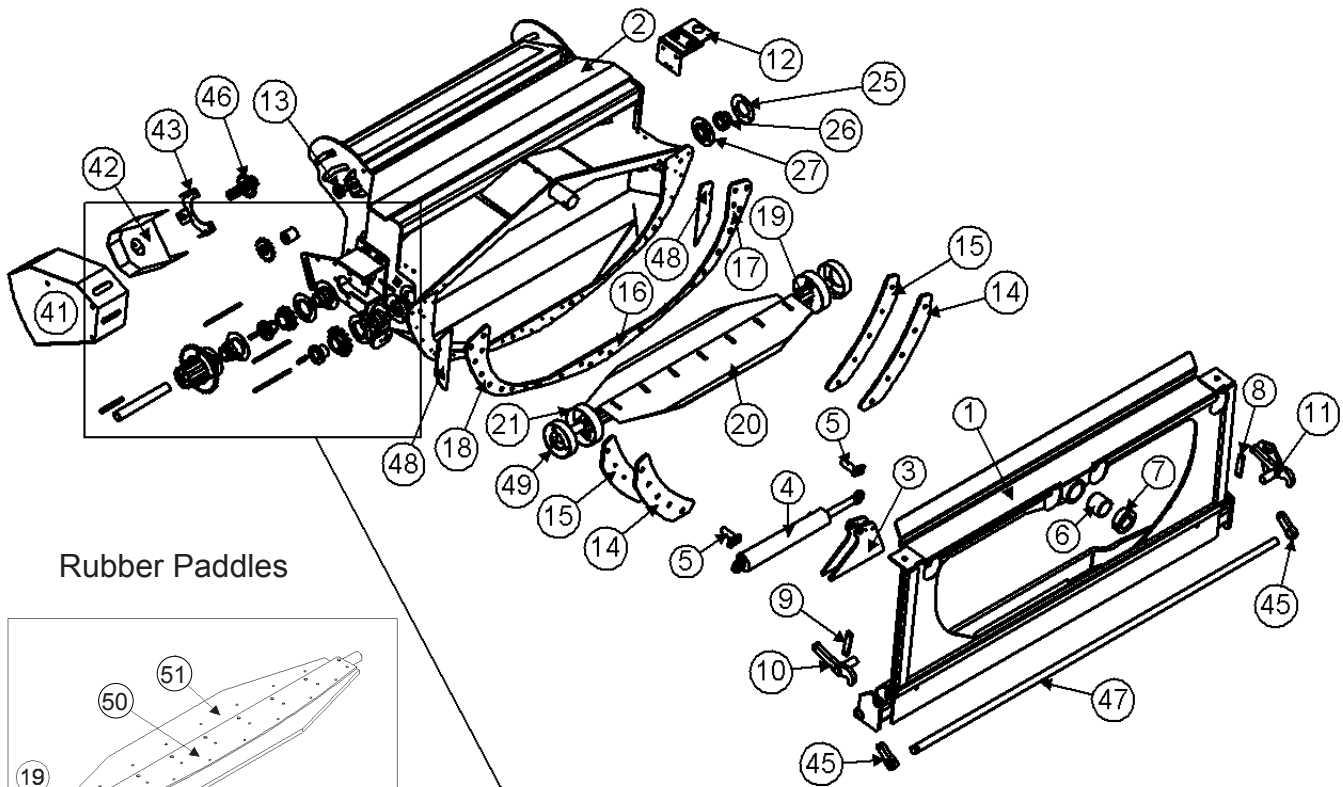

DRIVE COMPONENT DETAIL

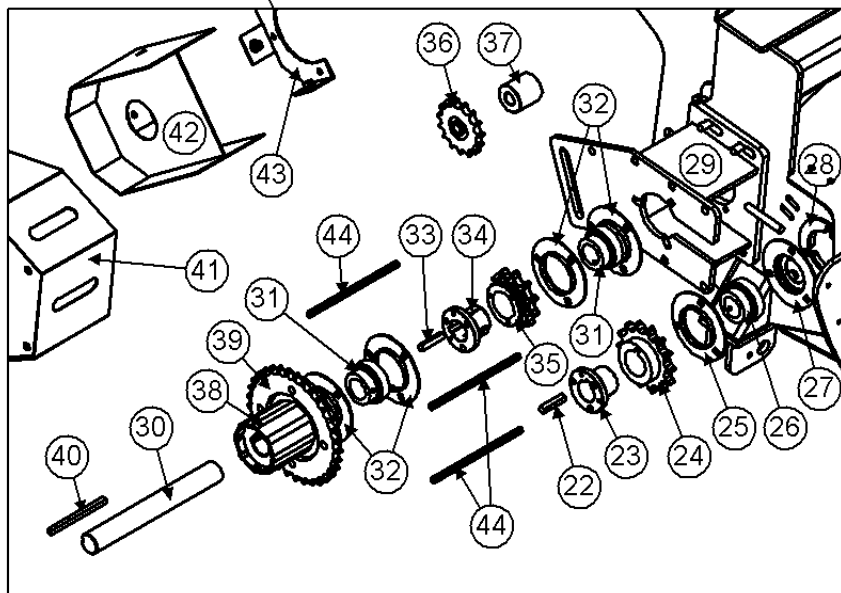

Model CH7010 Hillco Leveling System
For Serial Numbers CH7010-12001 thru CH7010-12999

TRANSITION COMPONENTS				
REF.	PART NO.	QTY.	PART NAME	NOTES
ASM	LA-298111	1	TRANSITION COMPLETE ASM	
1	LW-251516	1	TA ASM	
2	LW-267162	1	TT ASM	
3	LA-255141	1	TM MOUNT ASM, ROD	
4	HC-100706	1	CYLINDER, SLAVE	
5	LA-229071	2	TM PIN ASM, TRIM CYLINDER	
6	LTP-241721	1	BUSHING, PIVOT	
7	MC-150741	1	TM COLLAR, PIVOT	
8	LM-270201	1	TM LINKAGE, LH HDR LOCK	
9	LM-270211	1	TM LINKAGE, RH HDR LOCK	
10	LA-270251	1	TM ASM, RH HDR LATCH	
11	LA-270261	1	TM ASM, LH HDR LATCH	
12	LA-253621	1	TM ASM, HYDRAULIC COUPLER	
13	LM-251791	2	TM SPACER, EYEBOLT	
14	LP-249871	2	TM UHMW, BACKING	
15	LM-255121	2	TM PLATE, BACKING	
16	LM-255182	1	TM PLATE, WEAR BOTTOM	
17	LM-255192	1	TM PLATE, WEAR LH	
18	LM-255202	1	TM PLATE, WEAR RH	
BEATER SHAFT				
19	LA-251632	1	TB ASM, SHAFT	
20	LB-286321	2	TB PADDLE, METAL	
21	LW-292671	2	BEARING PROTECT WALL	
22	LS-212701	1	TM KEY, BEATER DRIVE	
23	MC-135511	1	HUB, SPLIT TAPER 1-7/16	
24	MC-136151	1	SPROCKET, 80P, 14T TAPER BORE	
25	MC-101339	1	FLANGETTES, RND BEARING (PAIR)	
26	MC-100548	2	INSERT, BEARING, 1-7/16	
27	LA-243691	2	TM ASM, INNER FLANGETTE	
28	LP-263111	2	TM SPACER, BEATER BEARING	
NS	LM-213243	1	TM CHAIN, 30 PIN 80 P	
NS	MC-142871	1	LINK, CONNECTING, 80P	
NS	MC-142881	1	LINK, OFFSET, 80P	
49	LW-292671	2	TM WLD BEARING PROTECT SHAFT	
TRANSITION THROAT JACK SHAFT				
29	LA-267351	1	TM ASM, JS MOUNT	
30	LM-267361	1	TT SHAFT, JACK	
31	MC-100548	2	INSERT, BEARING, 1-7/16	
32	MC-101339	2	FLANGETTES, RND BEARING (PAIR)	
33	LS-212701	1	TM KEY, JACK SHAFT	
34	MC-135511	1	HUB, SPLIT TAPER 1-7/16	
35	MC-135491	1	SPROCKET, 80P, 11T TAPER BORE	
36	MC-100237	1	SPROCKET, IDLER, 60P, 15T, 5/8B	
37	LM-251881	1	TM SPACER, 60P IDLER SPROCKET	
38	LA-259821	1	RADIAL PIN SLIP CLUTCH	
39	LM-226532	1	TM SPROCKET, RADIAL SLIP CLUTCH	
40	LS-244471	1	TM KEY, RADIAL SLIP CLUTCH	
NS	LP-251783	1	TM CHAIN, 70 PIN #60	
NS	MC-139361	1	LINK, CONNECTING, 60P	
NS	MC-139371	1	LINK, OFFSET, 60P	
41	LA-267431	1	TM ASM, FRONT SHIELD	
42	LA-267441	1	TM ASM, REAR SHIELD	
43	LA-267451	1	TM ASM, REAR SHIELD MOUNT	
44	LM-263021	3	TM ALL THREAD, MAIN DRIVE SHIELD	
45	LM-270191	1	TM ARM, RH LOWER PIVOT	
46	LA-267491	1	TM ASM, TRANSITION DRIVE	
47	LA-270272	1	TM ASM, HDR LATCH CROSS SHAFT	
OPTIONS FOR COMBINES WITH STEEL PADDLES				
48	LM-259861	2	TM PLATE, NARROWING	
OPTIONS FOR COMBINES WITH RUBBER PADDLES				
50	LM-272171	2	TB PLT, METAL BACKING	
51	LM-272181	2	TB PADDLE, RUBBER	
OPTION FOR GRASS				
NS	LP-262041	2	TM COVER, GRASS	18 OZ. TARP MATERIAL

Transition Fasteners

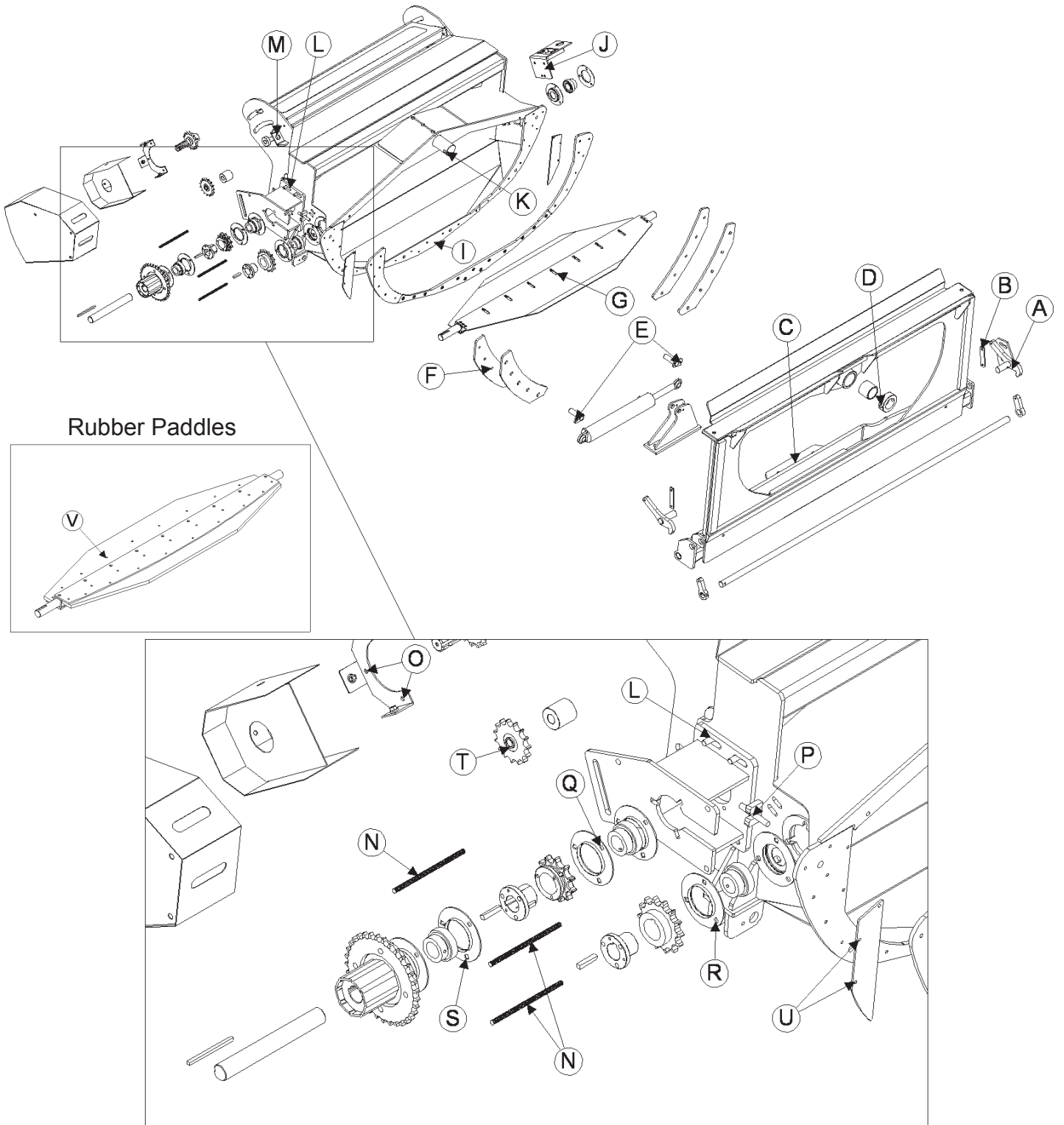

Model CH7010 Hillco Leveling System
For Serial Numbers CH7010-12001 thru CH7010-12999

TRANSITION FASTENERS				
REF.	PART NO.	QTY.	PART NAME	WHERE USED
A	F-PR-06X32	2	PIN, ROLL, 3/8 X 2 PLT	HEADER LOCK LINKAGE
A	F-HCF-10M060E	1	FLHC-10.9 M10 X 1.50 X 60 PLT	HEADER LOCK LINKAGE
A	F-HNS-10ME	1	HN-10.9 M10 X 1.50 STOVER PLT	HEADER LOCK LINKAGE
A	F-MB-18NR20	6	BUSHING, MACH 18 GA NR, 1-1/4 ID	HEADER LOCK LINKAGE
A	F-MB-18NR24	4	BUSHING, MACH 18 GA NR, 1-1/2 ID	HEADER LOCK LINKAGE
B	F-HCF-10M040E	4	FLHC-10.0 M10 X 1.50 X 40	LINKAGE TO LOWER PIVOT AND LOCK ARM
B	F-HNSF-10ME	4	FLHN-10.9 M10 X 1.50 STV	LINKAGE TO LOWER PIVOT AND LOCK ARM
C	F-HC-16M050E	3	HC-10.9 M16 X 2.00 X 50 PLT	ROD MNT
C	F-HNS-16ME	3	HN-10.9 M16 X 2.00 STV PLT	ROD MNT
D	F-HC-16M120E	1	HC-10.9 M16 X 2.00 X 120 PLT	TT PIVOT PIN COLLAR
D	F-HNS-16ME	1	HN-10.9 M16 X 2.00 STV PLT	TT PIVOT PIN COLLAR
E	F-HCF-10M020E	2	FLHC-10.9 M10 X 1.50 X 20 PLT	SLAVE CYLINDER MOUNT PIN
F	F-HCF-12M040E	10	FLHC-10.9 M12 X 1.75 X 40 PLT	BACKING PLATES
G	F-HNSF-12ME	9	FLHN-10.9 M12 X 1.75 STV FLNG PLT	STEEL PADDLES
G	F-HCF-12M080E	9	FLHC-10.9 M12 X 1.75 X 80 PLT	STEEL PADDLES
I	F-FHS-8M016E	29	FHSC-10.9 M8 X 1.25 X 16	TT FACE PLATE
J	F-HCF-10M025E	2	FLHC-10.9 M10 X 1.50 X 25 PLT	HEADER HYDRAULIC COUPLER MOUNT
J	F-HNF-10ME	2	FLHN-10.9 M10 X 1.50 PLT	HEADER HYDRAULIC COUPLER MOUNT
K	F-MB-14NR40	3	BUSHING, MACH 14 GA, NR, 2-1/2 ID	TT PIVOT PIN
L	F-HNF-12ME	4	FLHN-10.9 M12 X 1.75 PLT	TT 80P CHAIN ADJUSTER
M	F-EYB-20M150E	2	EYEBOLT M20 X 2.50 X 150	ANGLE ADJUSTMENT
M	F-HNF-20ME	4	FLHN-10.9 M20 X 2.50 PLT	ANGLE ADJUSTMENT
M	F-CB-12C56	2	CARR-GR. 5 3/4-10 X 3-1/2 PLT	ANGLE ADJUSTMENT
M	F-HNF-12C	2	FLHN-GR. 5 3/4-10 PLT	ANGLE ADJUSTMENT
N	F-HNF-10ME	12	FLHN-10.9 M10 X 1.50 PLT	MAIN BEATER DRIVE SHIELD
N	F-HNJ-10MF	3	HN-8.8 M10 X 1.50 JAM PLT	MAIN BEATER DRIVE SHIELD
O	F-HCF-08M020E	6	FLHC-10.9 M8 X 1.25 X 20	REAR TRANSITION DRIVE SHIELD
O	F-HNF-08ME	3	FLHN-10.9 M8 X 1.25	REAR TRANSITION DRIVE SHIELD
P	F-FWH-08	6	FW 1/2 HD YELLOW PLT	TT 80P CHAIN ADJUSTER
P	F-HNJ-12MF	2	HN-8.8 M12 X 1.75 JAM PLT	TT 80P CHAIN ADJUSTER
Q	F-HCF-10M016E	3	FLHC-10.9 M10 X 1.50 X 16 PLT	INNER JACKSHAFT BEARING
R	F-CB-10M030F	6	CARR-8.8 M10 X 1.50 X 30 PLT	TT BEATER BRNG
R	F-HNF-10MF	6	FLHN-8.8 M10 X 1.50 PLT	TT BEATER BRNG
S	F-CB-10M030F	3	CARR-8.8 M10 X 1.50 X 30 PLT	OUTER JACKSHAFT BEARING
S	F-HNF-10MF	3	FLHN-8.8 M10 X 1.50 PLT	OUTER JACKSHAFT BEARING
T	F-HC-16M110E	1	HC-10.9 M16 X 2.0 X 110 PLT	60P IDLER SPROCKET
T	F-HNS-16ME	1	HN-10.9 M16 X 2.0 STV PLT	60P IDLER SPROCKET
T	F-FWH-10	5	FW 5/8 HD	60P IDLER SPROCKET
OPTIONAL NARROWING PLATES				
U	F-HC-06M020F	6	HC-8.8 M6 X 1.0 X 20	NARROWING PLATES
U	F-HNF-6ME	6	FLHN-10.9 M6 X 1.0	NARROWING PLATES
OPTIONAL RUBBER PADDLES				
V	F-EB-04C20	34	BOLT, ELEVATOR, 1/4-20 X 1-1/4	RUBBER PADDLES
V	F-HNF-04C	34	FLHN 1/4-20, SERR	RUBBER PADDLES

Radial Pin Slip Clutch

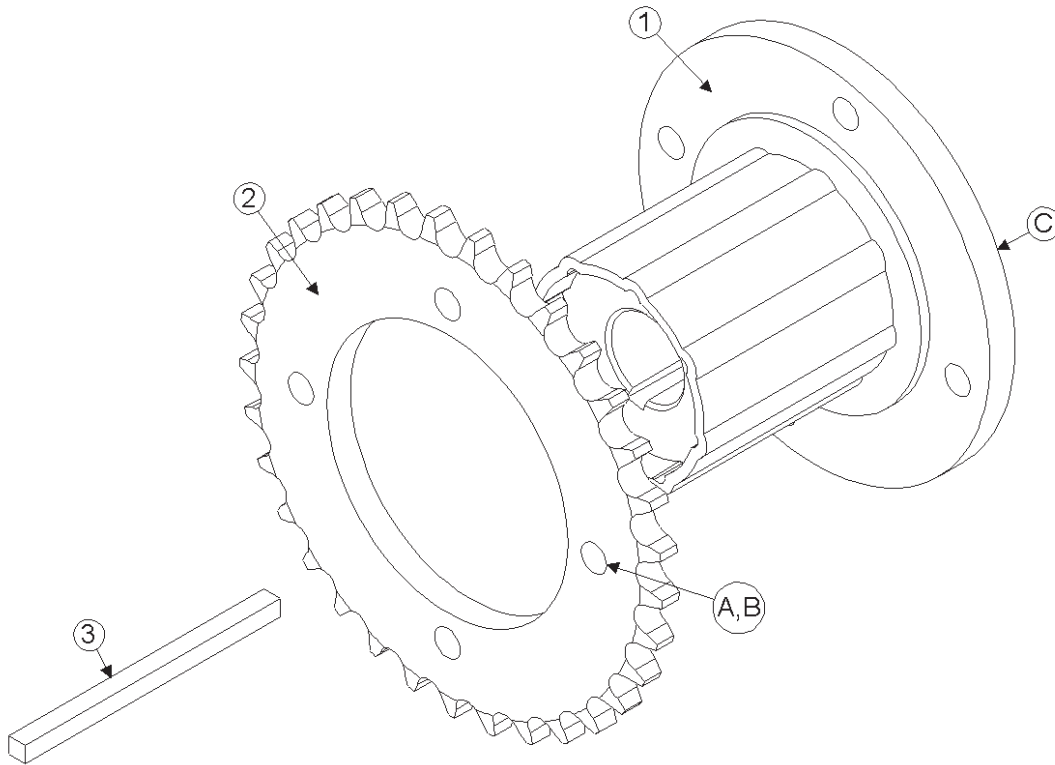

RADIAL PIN SLIP CLUTCH				
REF.	PART NO.	QTY.	PART NAME	NOTES
1	MC-150071	1	RADIAL PIN SLIP CLUTCH PIN 1-7/16B X 5/16 KEY	
2	LM-226532	1	TM SPROCKET, RADIAL SLIP CLUTCH	
3	LS-244471	1	TM KEY, RADIAL SLIP CLUTCH	
RADIAL PIN SLIP CLUTCH FASTENERS				
REF.	PART NO.	QTY.	PART NAME	WHERE USED
A	F-HC8-08F20	4	HC8 1/2-20 X 1-1/4	
B	F-LW-08A	4	LW 1/2 HD	
C	F-SSS-06C08	2	SCREW, SOCKET SET 3/8-16 X 1/2	

Model CH7010 Hillco Leveling System
For Serial Numbers CH7010-12001 thru CH7010-12999

Carriage

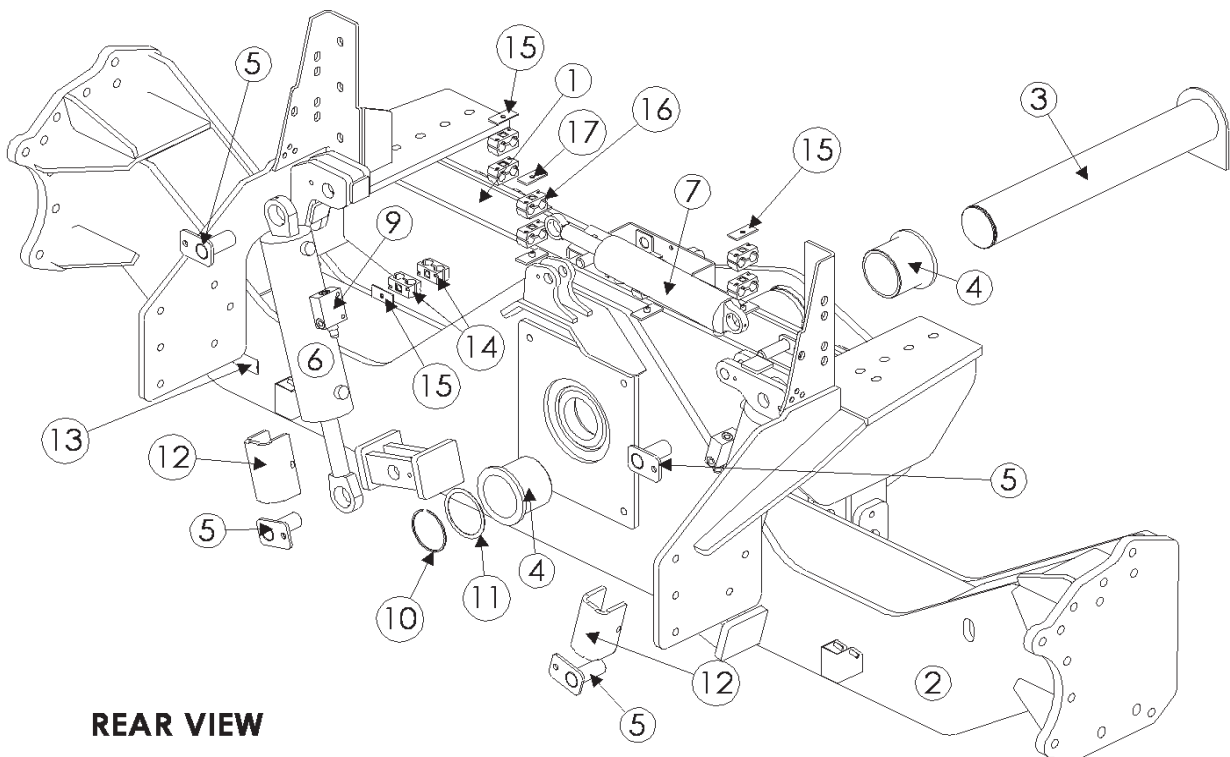
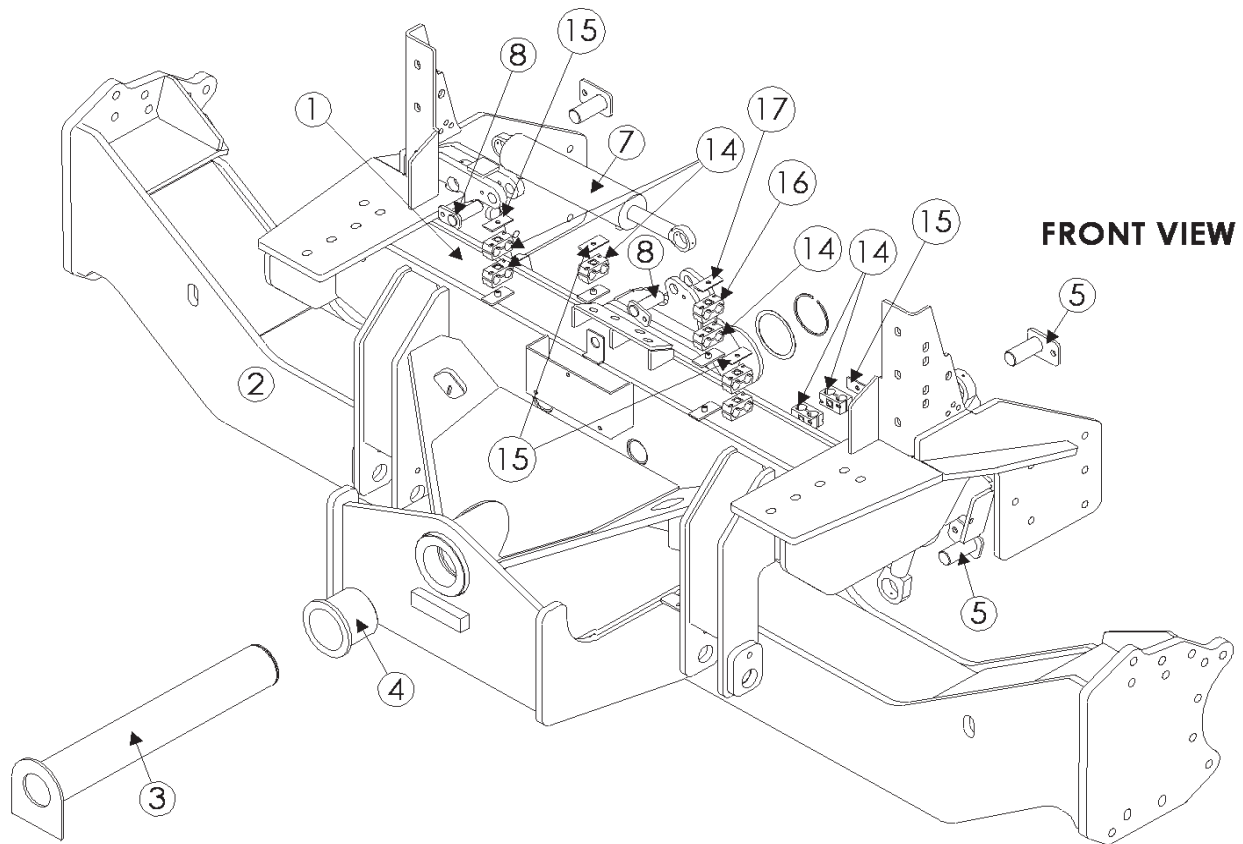

Model CH7010 Hillco Leveling System
For Serial Numbers CH7010-12001 thru CH7010-12999

CARRIAGE COMPONENTS				
REF.	PART NO.	QTY.	PART NAME	NOTES
ASM	LA-298091	1	OC/UC COMPLETE ASM	
1	LA-266631	1	CO ASM	
2	LA-266791	1	CU ASM	
3	LA-267021	1	CM ASM, MAIN PVT PIN	
4	LP-247961	2	CM BUSHING, PIVOT	
5	LA-230551	4	CM PIN ASM, MAIN CYLINDER	
6	HC-147511	2	CYLINDER, MAIN LEVELING	SEE PAGE 7-1
7	HC-147501	1	CYLINDER, MASTER LEVELING	SEE PAGE 7-1
8	LA-229071	2	TM PIN ASM, TRIM CYLINDER	
9	HC-138901	2	VALVE, 3-PORT COUNTERBALANCE	SEE PAGE 7-1
10	MC-138651	1	SNAP RING 4"	
11	MC-138641	1-4	WASHER 4.016ID X 4.764OD X .048	
12	LW-298001	2	CM WLD, CYLINDER STOP	
13	LA-295821	1	TAG, SERIAL NUMBER CH7010	
OPTIONAL-SAFETY STOPS				
NS	MC-137251	?	COLLAR, 2-PIECE CLAMPING W/ 2" BORE	QTY - AS NEEDED
NS	MC-137501	?	WASHER, QUICK REPAIR 2"	QTY - AS NEEDED
MISCELLANEOUS CARRIAGE COMPONENTS				
REF.	PART NO.	QTY.	PART NAME	NOTES
14	HC-139431	8	BEHRINGER TWIN CLAMP .750 DIAMETER	
15	HC-139451	2	BEHRINGER TWIN COVER PLATE (FOR .750)	
16	HC-139481	1	BEHRINGER TWIN CLAMP .620 DIAMETER	
17	HC-139501	1	BEHRINGER TWIN COVER PLATE (FOR .620)	

Model CH7010 Hillco Leveling System
For Serial Numbers CH7010-12001 thru CH7010-12999

Carriage Fasteners

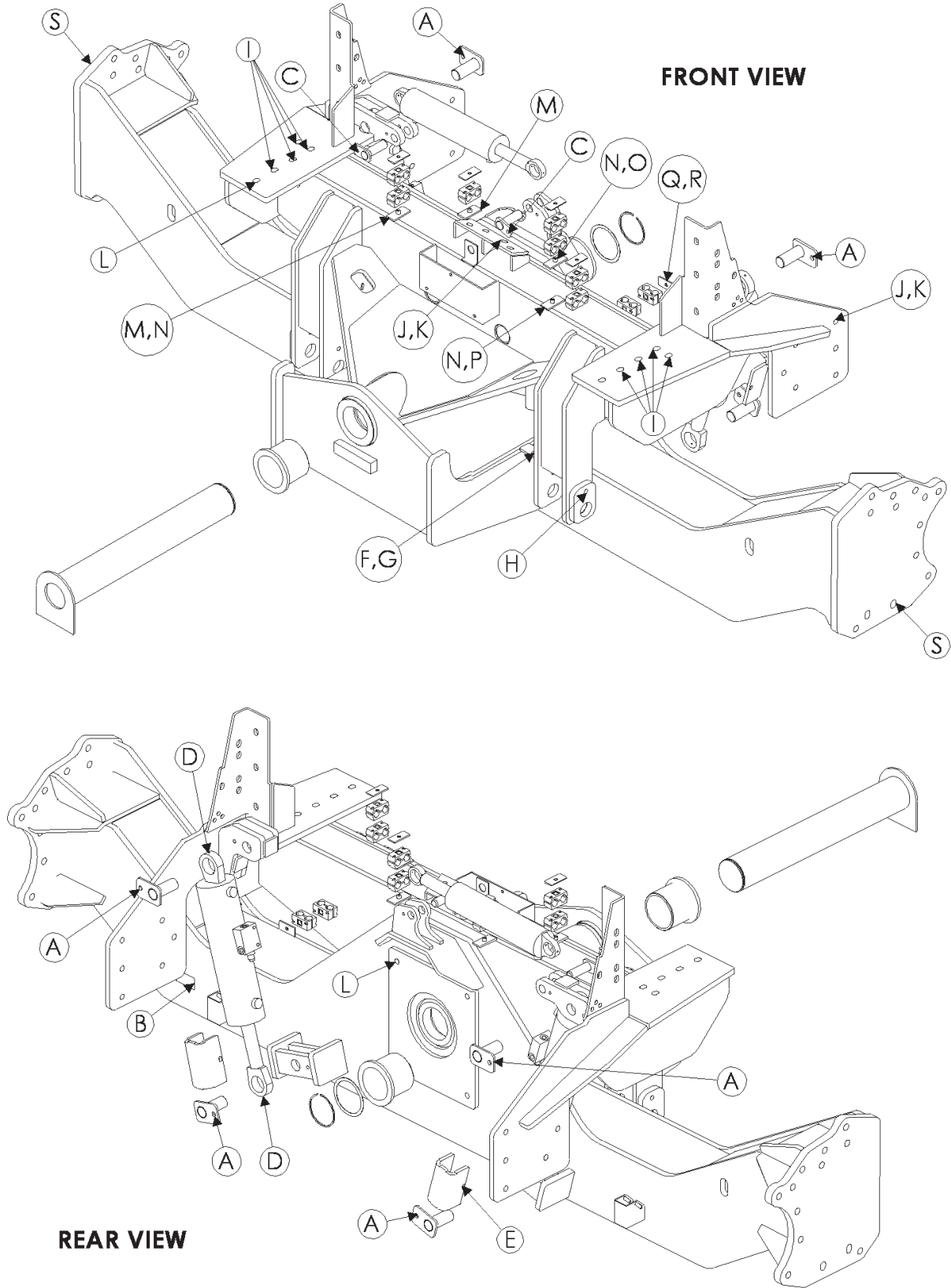

Model CH7010 Hillco Leveling System
For Serial Numbers CH7010-12001 thru CH7010-12999

CARRIAGE FASTENERS				
REF.	PART NO.	QTY.	PART NAME	WHERE USED
A	F-HCF-12M025F	4	FLHC-8.8 M12 X 1.75 X 25 PLT	LEVELING CYL MNT PIN
B	F-UDS-#7X06	2	#7 X 3/8 U-DRIVE SCREW	SERIAL NUMBER PLATE
C	F-HCF-10M020E	2	FLHC-10.9 M10 X 1.50 X 20 PLT	MASTER CYL MNT PIN
D	F-SSS-04F04	6	SET SCREW, 1/4-28 X 1/4	CYLINDERS
E	F-PSL-04X48	2	SNAP LOCK PIN 1/4 X 3	SAFETY STOPS ON CYLINDERS
F	F-EB-04C32	2	BOLT, ELEV 1/4-20 X 2 PLT	LIMIT SWITCH STOPS
G	F-HNF-04C	4	HN 1/4-20 FLG SERR	LIMIT SWITCH STOPS
H	F-HC-12M065F	2	HC-8.8 M12 X 1.75 X 65	HEADER LIFT CYLINDER PINS
I	F-HCF-16M045E	8	FLHC-10.9 M16 X 2.00 X 45	OC BASE PLATE
J	F-HCF-16M040E	8	FLHC-10.9 M16 X 2.00 X 40	X-BRACES & OC TO C-CHANNEL
K	F-HNF-16ME	8	FLHN-10.9 M16 X 2.00	X-BRACES & OC TO C-CHANNEL
L	F-HCF-16M050E	6	FLHC-10.9 M16 X 2.00 X 50	TRANSMISSION & FRONT OC BASE PLATE
M	HC-139461	1	BEHRINGER TWIN BOLT (FOR .750)	
M	HC-139471	1	BEHRINGER STACK BOLT (FOR .750)	
O	HC-139511	1	BEHRINGER TWIN BOLT (FOR .620)	
P	F-HC5-05C32	1	HC5 5/16-18 X 2	
Q	F-HC-08M100F	1	HC-8.8 M8 X 1.25 X 100	
R	F-HNF-08ME	1	FLHN-10.9 M8 X 1.25	
S	F-HC-20M070E	26	HC-10.9 M20 X 2.5 X 70	CHN P/N: 827-20070

Model CH7010 Hillco Leveling System
 For Serial Numbers CH7010-12001 thru CH7010-12999

Drop Axle

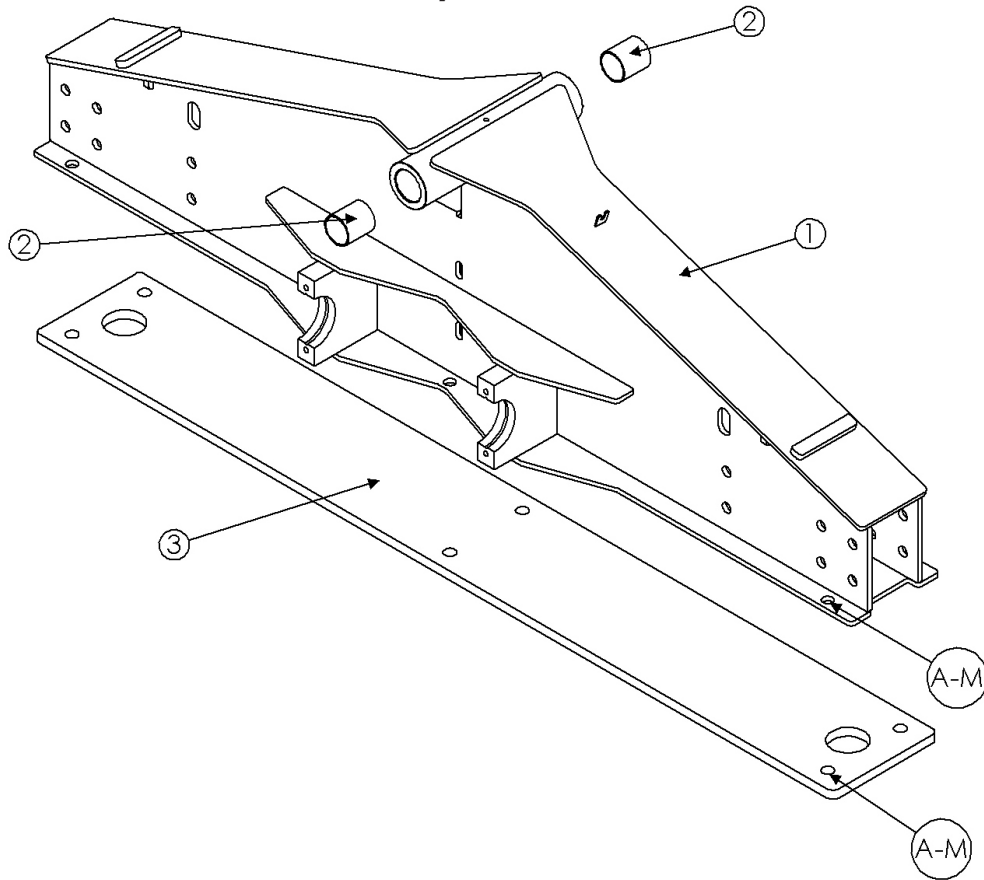

DROP AXLE COMPONENTS				
REF.	PART NO.	QTY.	PART NAME	NOTES
ASM	LA-267531	1	DA COMPLETE ASM, 3700	
1	LA-269851	1	DA ASM	
2	MC-140791	2	REAR AXLE PIVOT SLEEVE	CNH Part # 84334438
3	LP-274461	0-10	DA WEIGHT, 159 LB.	
DROP AXLE FASTENERS				
A	F-HC8-12C56	6	HC8 3/4-10 X 3-1/2	1 WEIGHT BOLT PACKAGE
B	F-HC8-12C56	6	HC8 3/4-10 X 3-1/2	2 WEIGHT BOLT PACKAGE
C	F-HC8-12C72	6	HC8 3/4-10 X 4-1/2	3 WEIGHT BOLT PACKAGE
D	F-HC8-12C88	6	HC8 3/4-10 X 5-1/2	4 WEIGHT BOLT PACKAGE
E	F-HC8-12C96	6	HC8 3/4-10 X 6	5 WEIGHT BOLT PACKAGE
F	F-HC8-12C112	6	HC8 3/4-10 X 7	6 WEIGHT BOLT PACKAGE
G	F-HC8-12C120	6	HC8 3/4-10 X 7-1/2	7 WEIGHT BOLT PACKAGE
H	F-HC8-12C136	6	HC8 3/4-10 X 8-1/2	8 WEIGHT BOLT PACKAGE
I	F-HC8-12C144	6	HC8 3/4-10 X 9	9 WEIGHT BOLT PACKAGE
J	F-HC8-12C160	6	HC8 3/4-10 X 10	10 WEIGHT BOLT PACKAGE
K	F-HN8-12C	6	HN8 3/4-10	ALL WEIGHT BOLT PACKAGES
L	F-LW-12A	6	LW 3/4 HD	ALL WEIGHT BOLT PACKAGES
M	F-FWH-12	6	FW 3/4 HD	ALL WEIGHT BOLT PACKAGES

Model CH7010 Hillco Leveling System
For Serial Numbers CH7010-12001 thru CH7010-12999

Ladder

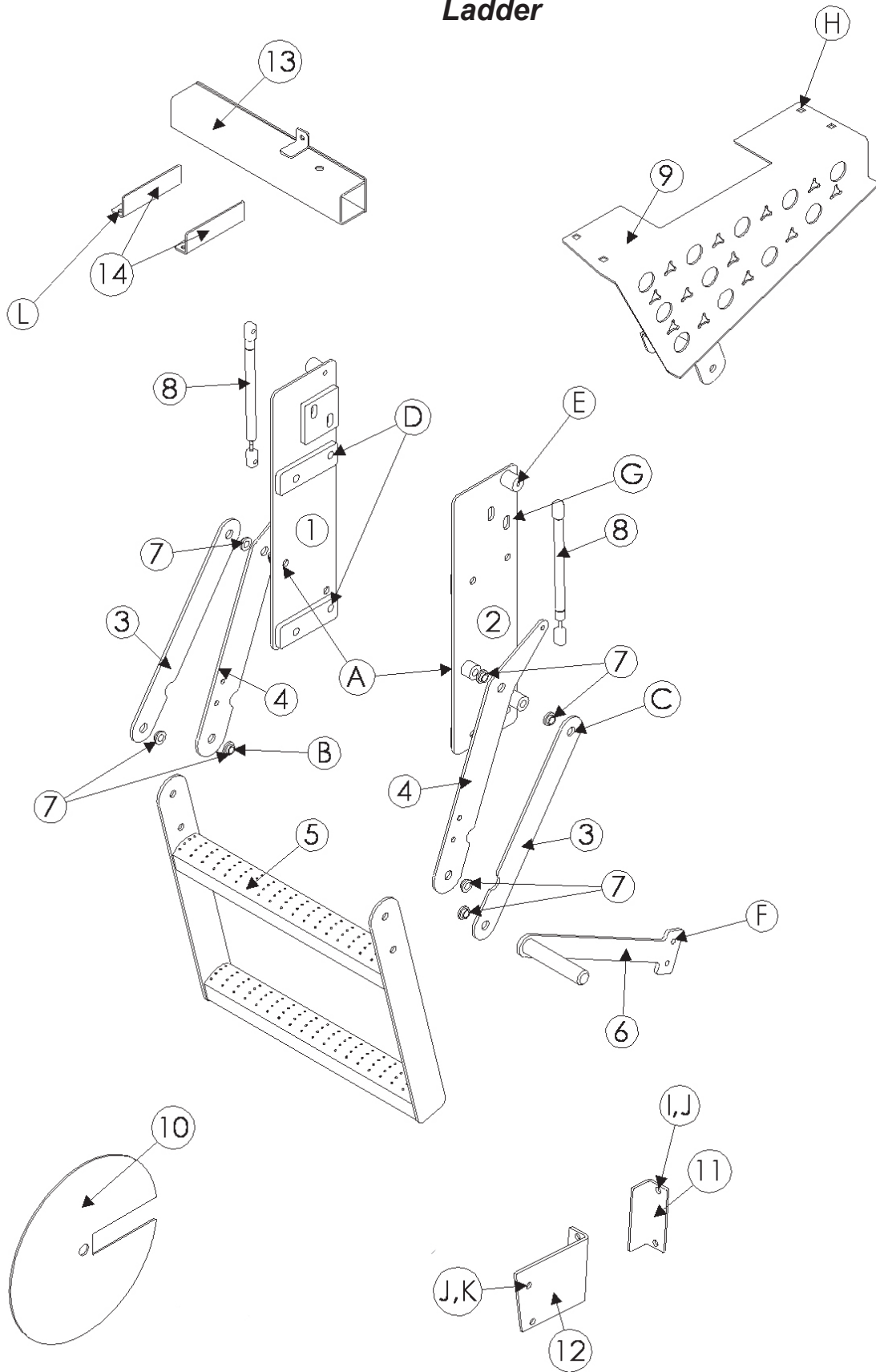

Model CH7010 Hillco Leveling System
For Serial Numbers CH7010-12001 thru CH7010-12999

LADDER COMPONENTS				
REF.	PART NO.	QTY.	PART NAME	NOTES
ASM	LA-267541	1	LM ASM, 3700 FOLDING LADDER	
1	LA-266991	1	LM ASM, LEFT LADDER MNT	
2	LA-267001	1	LM ASM, RIGHT LADDER MNT	
3	LM-266971	2	LM PLT, FOLDING LADDER LINK	
4	LM-266961	2	LM PLATE, UPPER ARM	
5	LA-267011	1	LM STEP ASM, FOLDING LDR	
6	LA-248861	1	LM ASM, LADDER HANDLE	
7	LM-267981	8	LM BUSHING, LADDER PIVOT	
8	MC-139251	2	GAS CHARGED LIFT SUPPORT (60 LB)	
9	LA-268831	1	LM ASM, LADDER WEDGE	
10	LP-268711	1	LM PLATE, PULLEY SHIELD	
11	LP-268781	1	LM CLAMP, FRONT HANDRAIL	
12	LP-268791	1	LM MOUNT, FRONT HANDRAIL	
13	LA-268741	1	LM ASM, RH FLASHING LIGHT	
14	LP-268721	2	LM CLAMP, RH FLASHING LIGHT	
NS	MC-134931	2	LIFT SUPPORT BRACKETS (PAIR)	

LADDER FASTENERS				
REF.	PART NO.	QTY.	PART NAME	WHERE USED
A	F-HC-12M050F	2	HC-8.8 M12 X 1.75 X 50 PLT	TOP SIDE PLATE PIVOT
A	F-HNS-12ME	2	HN-10.9 M12 X 1.75 ST PLT	TOP SIDE PLATE PIVOT
B	F-HC-12M030F	4	HC-8.8 M12 X 1.75 X 30 PLT	MIDDLE PIVOTS
B	F-HNS-12ME	4	HN-10.9 M12 X 1.75 ST PLT	MIDDLE PIVOTS
C	F-HC-12M065F	2	HC-8.8 M12 X 1.75 X 65 PLT	BOTTOM SIDE PLT PIVOTS
C	F-HNS-12ME	2	HN-10.9 M12 X 1.75 ST PLT	BOTTOM SIDE PLT PIVOTS
D	F-HCF-10M040E	8	FLHC-10.9 M10 X 1.50 X 40	SIDE PLATE MOUNTS
D	F-HNF-10ME	8	FLHN-10.9 M10 X 1.50	SIDE PLATE MOUNTS
E	F-HNJ-05C	2	HN5 5/16-18 JAM NUT PLT	BALL STUD
E	F-LW-05	4	LW 5/16	BALL STUD
F	F-HC-08M025F	2	HC-8.8 M8 X 1.25 X 25 PLT	HANDLE
F	F-HNF-08ME	2	FLHN-10.9 M8 X 1.25 PLT	HANDLE
G	F-HCF-10M035E	4	FLHC-10.9 M10 X 1.50 X 35	HANDLES
G	F-HNF-10ME	4	FLHN-10.9 M10 X 1.50	HANDLES
H	F-CB-10M030F	2	CARR-8.8 M10 X 1.50 X 30	WEDGE
H	F-HNF-10ME	2	FLHN-10.9 M10 X 1.50	WEDGE
I	F-HC-10M110E	2	HC-10.9 M10 X 1.50 X 110	FRONT HANDRAIL MOUNT
J	F-HNF-10ME	4	FLHN-10.9 M10 X 1.50	FRONT HANDRAIL MOUNT
K	F-HCF-10M050E	2	FLHC-10.9 M10 X 1.50 X 50	FRONT HANDRAIL MOUNT
L	F-HC-08M120F	4	HC-8.8 M8 X 1.25 X 120	RH FLASHING LIGHT BRACKET
L	F-HNF-08ME	4	FLHN-10.9 M8 X 1.25	RH FLASHING LIGHT BRACKET

Electrical

MAIN ELECTRICAL CONTROL BOX

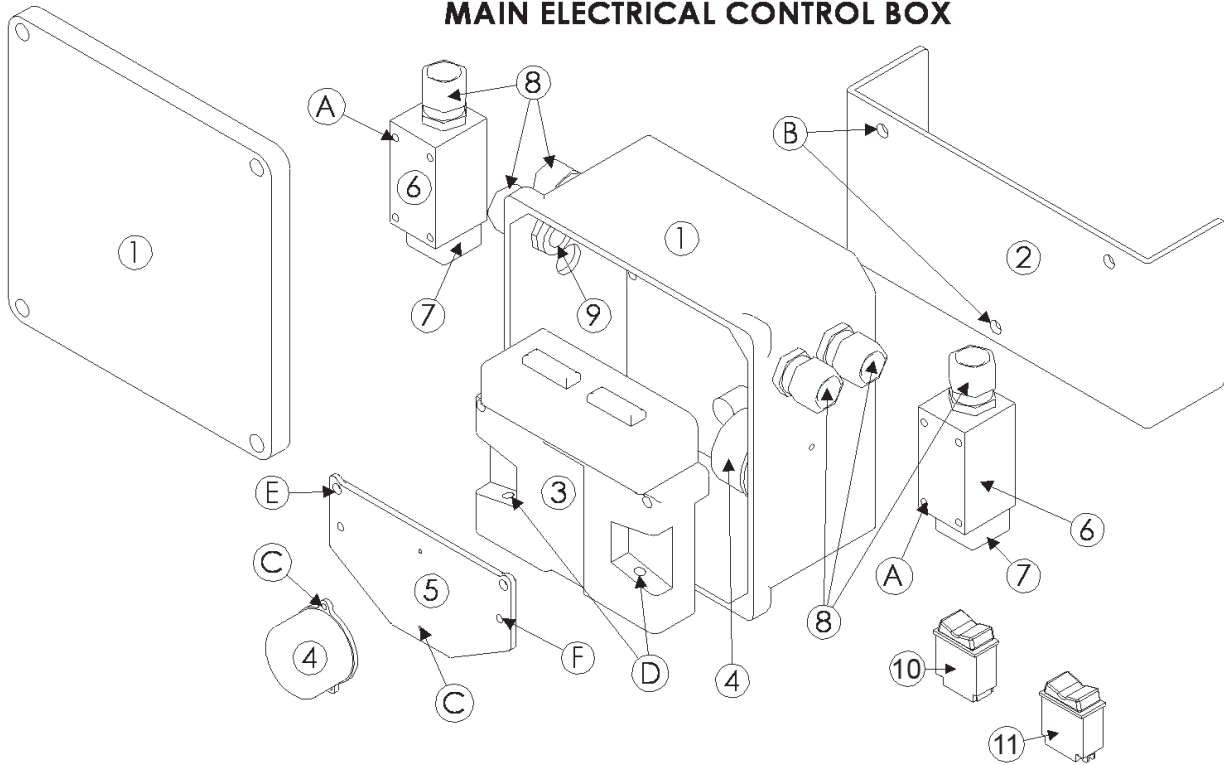

Cab Control Monitor Assembly

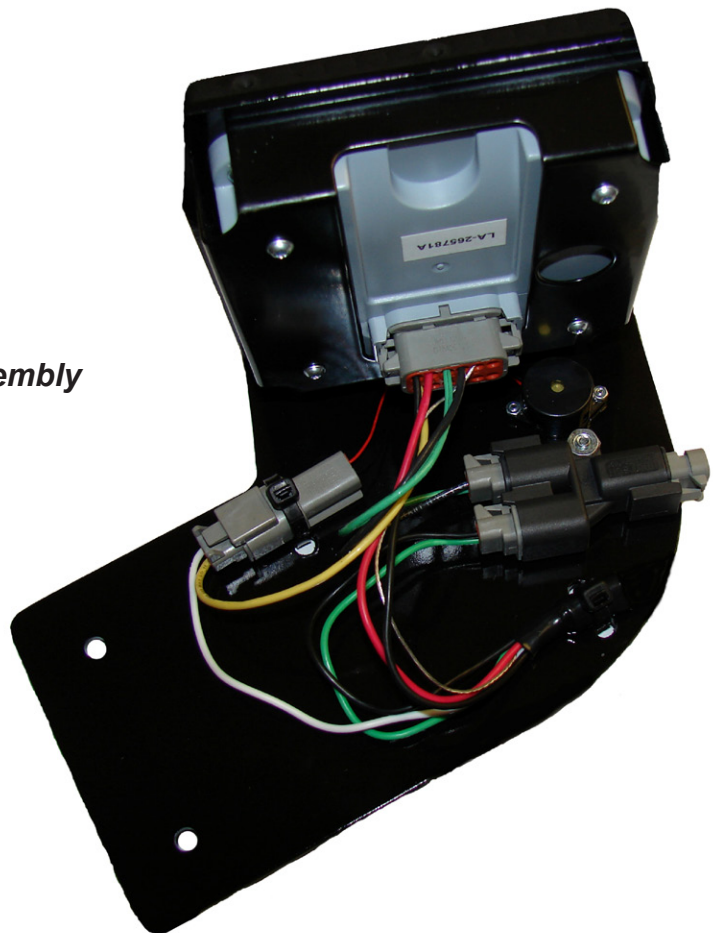

Model CH7010 Hillco Leveling System
For Serial Numbers CH7010-12001 thru CH7010-12999

MAIN ELECTRICAL BOX COMPONENTS				
REF.	PART NO.	QTY.	PART NAME	NOTES
ASM	LA-268271	1	EM ASM, CONTROLLER	
1	LM-260301	1	EM BOX, CONTROLLER MOUNT	
2	LP-266511	1	EM MOUNT, LEVELING BOX	WELDED TO CARRIAGE
3	EC-141831	1	CONTROLLER	
4	LA-255821	2	EM ASM, CLINOMETER	SEE NOTE BELOW DIAGRAM
5	LM-255331	1	EM SHT, CLINOMETER MOUNT	
6	EC-100557	2	BODY, LIMIT SWITCH	
7	EC-100692	2	HEAD, LIMIT SWITCH STRAIGHT PLUNGER	
8	EC-138781	6	STRAIN RELIEF, NYLON, BLK, 1/2 NPT	
9	EC-142121	4	STRAIN RELIEF NUT, 1/2" NYLON, BLK	
REMOTE SWITCH CONTROLS				
REF.	PART NO.	QTY.	PART NAME	NOTES
ASM	LA-281881	1	EM PACKAGE, REMOTE SWITCH	
10	EC-143401	1	SWITCH, LEFT/RIGHT LEVELING	
11	EC-150501	1	SWITCH, AUTO/MANUAL	
FASTENERS				
REF.	PART NO.	QTY.	PART NAME	WHERE USED
A	F-PHM-#10C28	8	PHMS 10-24 X 1-3/4	LIMIT SWITCH MNT
A	F-HNF-#10C	8	HN 10-24, FLNG SERR	LIMIT SWITCH MNT
B	F-HC5-04C12	3	HC5 1/4-20 X 3/4	PVC BOX TO BRACKET
B	F-LW-04	3	LW 1/4	PVC BOX TO BRACKET
C	F-PHM-#6C06	2	PHMS #6-32 X 3/8	CLINOMETER MOUNT
D	F-PHM-04C24	2	PHMS 1/4-20 X 1-1/2	CONTROLLER TO PVC BOX
D	F-HNF-04C	2	FLHN 1/4-20 SERR.	CONTROLLER TO PVC BOX
E	F-PHM-04C36	2	PHMS 1/4-20 X 2-1/4	GROUNDING PLATE MOUNTING
E	F-HNF-04C	2	FLHN 1/4-20 SERR.	GROUNDING PLATE MOUNTING
F	F-PHM-#10C12	2	PHMS 10-24 X 3/4	GROUNDING PLATE GROUND
F	F-HNF-#10C	2	HN5 10-24, FLNG SERR	GROUNDING PLATE GROUND
F	F-HN-#10C	2	HN 10-24	GROUNDING PLATE GROUND
CAB CONTROL MONITOR DISPLAY				
REF.	PART NO.	QTY.	PART NAME	NOTES
ASM	LA-268361	1	EM ASM, CAB CONTROL MONITOR	
..	LM-268281X	1	EM MOUNT, DISPLAY	
..	EC-146461	1	GRAPHICAL TERMINAL, S-D DP200	COMES WITH MOUNTING BRACKET, GASKET AND SCREWS
..	LA-268301	1	EM CABLE ASM, CAB TO BOX	SEE PAGE 6-3
..	LA-265791	1	EM CABLE ASM, BUZZER	SEE PAGE 6-3
..	EC-146481	1	BUZZER, PIEZO ELECTRIC	INCLUDED IN LA-265791
..	EC-146531	1	Y-CONNECTOR, BLACK	
..	EC-146541	1	PLUG, GRAY, W/120 OHM RESISTOR	
..	EC-138781	2	STRAIN RELIEF, NYLON, BLK, 1/2 NPT	
..	EC-142121	2	STRAIN RELIEF NUT, 1/2" NYLON, BLK	
FASTENERS				
..	F-PHM-#10C08	1	PHMS 10-24 X 1/2	Y-CONNECTOR MOUNTING
..	F-HN-#10C	1	HN5 10-24	Y-CONNECTOR MOUNTING
..	F-HN-#2C	2	HN #2-56	FASTEN PIEZO BUZZER TO MONITOR MOUNT
..	F-PHM-#2C05	2	PHMS #2-56 X 5/16	FASTEN PIEZO BUZZER TO MONITOR MOUNT

Electrical Connectors and Cables



#1 LA-268261
EM CABLE ASM, LIMIT SWITCH



#2 LA-268311
EM CABLE ASM, BOX TO VALVE



#3 LA-261191
EM ASM, CLINOMETER



#4 LA-268351
EM CABLE ASM, MANIFOLD



#5 LA-268301
EM CABLE ASM, CAB TO BOX



#7 LA-268291
EM CABLE ASM, POWER & GROUND

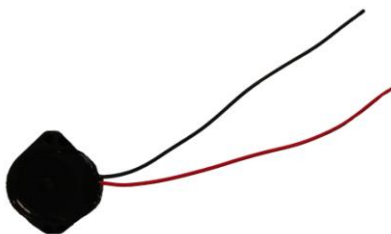

#6 LA-265791
EM CABLE ASM, BUZZER



#8 LA-289201
EM CABLE ASM, REMOTE SWITCH

Model CH7010 Hillco Leveling System
For Serial Numbers CH7010-12001 thru CH7010-12999

CABLE ASSEMBLIES				
REF.	PART NO.	QTY.	PART NAME	NOTES
1	LA-268261	2	EM CABLE ASM, LIMIT SWITCH	
2	LA-268311	1	EM CABLE ASM, BOX TO VALVE	
3	LA-261191	1	EM ASM, CLINOMETER	
4	LA-268351	1	EM CABLE ASM, MANIFOLD	
..	LA-268341	1	EM CABLE ASM, LEVELING MANIFOLD	INCLUDED IN LA-268351
..	LA-268331	1	EM CABLE ASM, RWA SIGNAL	INCLUDED IN LA-268351
5	LA-268301	1	EM CABLE ASM, CAB TO BOX	
6	LA-265791	1	EM CABLE ASM, BUZZER	
..	EC-146481	1	BUZZER, PIEZO ELECTRIC	INCLUDED IN LA-265791
7	LA-268291	1	EM CABLE ASM, POWER & GROUND	
8	LA-289201	1	EM CABLE ASM, REMOTE SWITCH	
ELECTRICAL CONNECTORS				
REF.	PART NO.	QTY.	PART NAME	NOTES
NS	EC-141741	4	DTM SERIES, 12-SOCKET WEDGE	
NS	EC-141751	3	DTM SERIES, 12-SOCKET PLUG-GRAY	
NS	EC-141761	1	DTM SERIES, 12-SOCKET PLUG-BLACK	
NS	EC-143261	1	DTM SERIES, 12-PIN, RECEPTACLE	
NS	EC-143271	1	DTM SERIES, 12-PIN WEDGE	
NS	EC-146521	2	DTM SERIES, 2-SOCKET WEDGE	
NS	EC-146611	1	DTM SERIES, 2-PIN WEDGE, BLACK	
NS	EC-146581	36	DTM SERIES, SOCKET CONTACT, SOLID	
NS	EC-146591	7	DTM SERIES, PIN CONTACT, SOLID	
NS	ET-ST-20#10	6	TERMINAL, RING, #10, 20 GA., NON-INS.	
NS	ET-ST-2004	1	TERMINAL, RING, NON-INS, 1/4, 20 GA	
NS	ET-ST-1406	1	TERMINAL, RING, 3/8, 14 GA, NON-INS.	
NS	EC-136661	2	TERMINAL, MALE PIN, WP	
NS	EC-136621	2	TERMINAL, FEMALE SLEEVE, WP	
NS	EC-143211	1	CONNECTOR, 2-MALE, WP	
NS	EC-143221	1	CONNECTOR, 2-FEMALE, WP	
NS	EC-139631	1	CONNECTOR, PARALLEL, 12-10 GA	
NS	EC-139641	3	CONNECTOR, PARALLEL, 16-14 GA	
NS	EC-146601	1	RECEPTACLE, GRAY, 2-PIN	
NS	EC-146881	1	MINI FUSE HOLDER, ATM	
NS	EC-146891	1	MINI BLADE FUSE, ATM, 5AMP	
NS	ET-SP-16	5	FEMALE SPADE	

Hydraulics

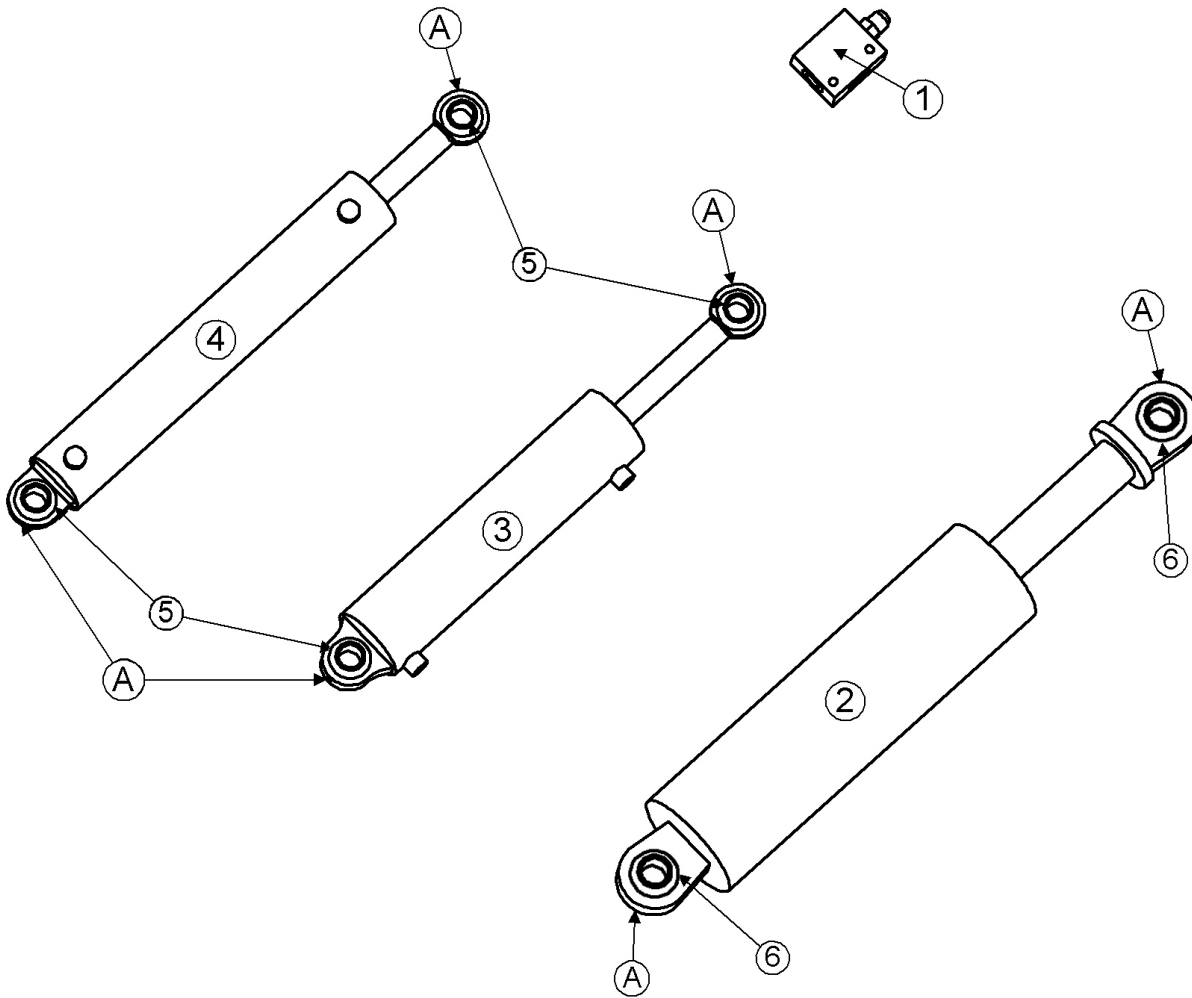

COUNTERBALANCE VALVE AND CYLINDERS				
REF.	PART NO.	QTY.	PART NAME	NOTES
1	HC-138901	2	VALVE, 3-PORT COUNTERBALANCE	MAIN LEVELING CYLINDERS BASE END
..	HC-139171	2	BODY, COUNTERBALANCE VALVE	
..	HC-139161	2	CARTRIDGE, COUNTERBALANCE VALVE	
NS	HC-140361	2	SEAL KIT, COUNTERBALANCE VALVE	
2	HC-103227	2	CYLINDER, MAIN LEVELING	SUBS TO HC-147511
..	HC-134251	2	SEAL KIT, MAIN LEVELING CYLINDER	
3	HC-101842	1	CYLINDER, MASTER LEVELING	SUBS TO HC-147501
..	HC-134201	1	SEAL KIT, MASTER LEVELING CYLINDER	
4	HC-100706	1	CYLINDER, SLAVE	SUBS TO HC-147491
..	HC-140011	1	SEAL KIT, SLAVE CYLINDER	
5	MC-150871	4	1" BEARING, SEALED SPHERICAL	
6	MC-150881	4	1 3/8" BEARING, SEALED SPHERICAL	
HYDRAULIC FASTENERS				
REF.	PART NO.	QTY.	PART NAME	WHERE USED
A	F-SSS-04F04	6	SET SCREW, 1/4-28 X 1/4	ALL CYLINDERS

Code 62 Adapters

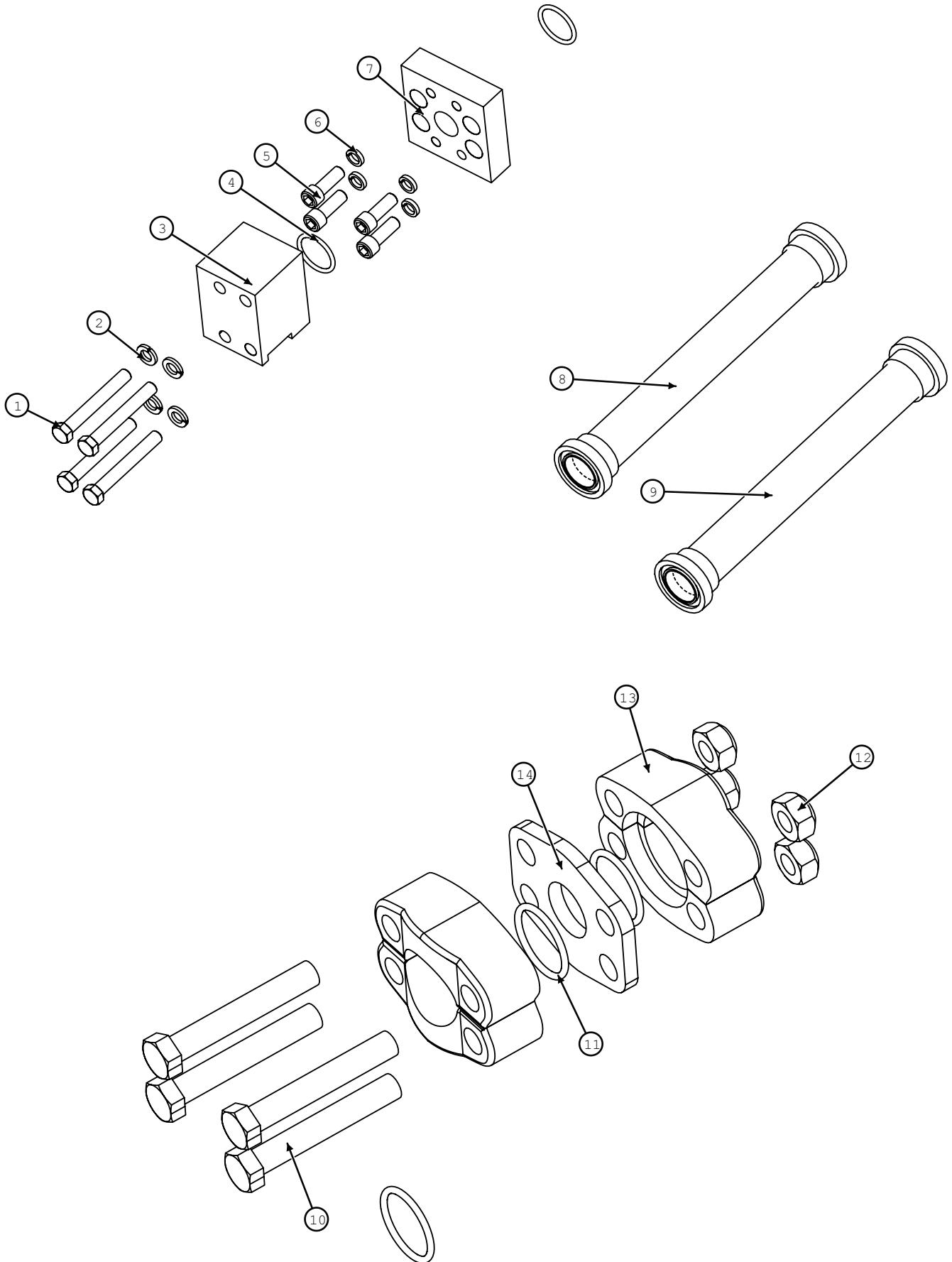

Model CH7010 Hillco Leveling System
For Serial Numbers CH7010-12001 thru CH7010-12999

CODE 62 ADAPTERS			
REF.	PART NO.	QTY.	PART NAME
1	F-HC8-07C52	4	HC8 7/16-14 X 3-1/4
2	F-LWH-07	8	LW 7/16 HD
3	LM-261081	1	HM BLOCK, CODE 62 90°
4	HC-147551	3	O-RING, CODE 62, 1"
5	F-SHC-07C20	4	SHCS 7/16-14 X 1-1/4
6	F-LWHC-07	4	LW 7/16 HD HIGH COLLAR
7	HC-143371	1	CODE 62 90° ROTATIONAL ADAPTER
8	HC-152551	1	EXTENSION, 1-1/4 CODE 62, EACH END, 8-1/2" LENGTH
9	HC-152581	1	EXTENSION, 1-1/4 CODE 62, EACH END, 7-1/2" LENGTH

10-14	LA-254951	2	KIT, HOSE COUPLER, 1-1/4 CODE 62
10	F-HC-14M090E	8	HC-10.9 M14 X 2.00 X 90
11	HC-147621	6	O-RING, CODE 62, 1-1/4"
12	F-HNS-14ME	8	HN-10.9 M14 X 2.00 STOVER
13	HC-147611	8	FLANGE, 1-1/4" CODE 62, HALF
14	LM-272161	2	HM PLT, CODE 62 1-1/4 UNION

Hydraulic Manifold

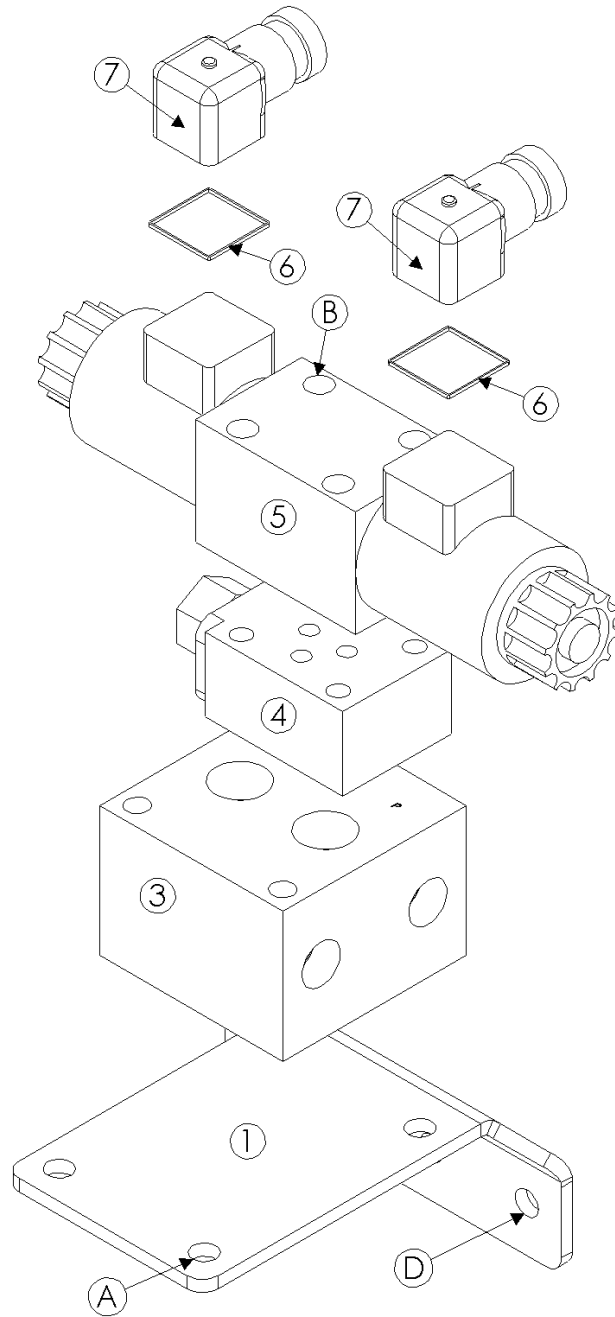

Model CH7010 Hillco Leveling System
For Serial Numbers CH7010-12001 thru CH7010-12999

MANIFOLD COMPONENTS				
REF.	PART NO.	QTY.	PART NAME	NOTES
ASM	LA-300791	1	LEVELING MANIFOLD ASM	
1	LW-300781	1	HM PLATE, MANIFOLD MOUNT	
2	HC-138691	1	MANIFOLD, RELIEF VALVE	HEADER TRIM CIRCUIT
..	HC-141351	2	CARTRIDGE, RELIEF VALVE	
NS	HC-141361	2	SEAL KIT, RELIEF VALVE	
3	HC-138861	1	MANIFOLD, SINGLE STATION	
4	HC-101264	1	SHUTTLE ASM, LOAD SENSE	
..	HC-101021	1	CARTRIDGE, LOAD SENSE VALVE	
..	HC-101022	1	BODY, LOAD SENSE VALVE	
NS	HC-102082	1	SEAL KIT, LOAD SENSE SHUTTLE ASM	
5	HC-140411	1	DIRECTIONAL CONTROL VALVE	
NS	LM-250111	1	ORIFICE, .128	
NS	HC-142731	1	SEAL KIT, DIRECTIONAL CONTROL VALVE	
6	HC-142971	2	GASKET, DIN CONNECTOR	
7	HC-140291	2	PLUG, DIN, LIGHTED	
MANIFOLD FASTENERS				
REF.	PART NO.	QTY.	PART NAME	WHERE USED
A	F-HCF-08M020E	4	FLHC-10.9 M8 X 1.25 X 20 PLT	
A	F-HNF-08ME	4	FLHN-10.9 M8 X 1.25 PLT	
B	F-SHC-#10C52	4	SHCS 10-24 X 3-1/4	
B	F-LW-#10	4	LW #10	
C	F-HCF-08M050E	2	FLHC-10.9 M8 X 1.25 X 50	
C	F-HNF-08ME	2	FLHN-10.9 M8 X 1.25 PLT	
D	F-HCF-08M020E	2	FLHC-10.9 M8 X 1.25 X 20 PLT	
D	F-HNF-08ME	2	FLHN-10.9 M8 X 1.25 PLT	

Model CH7010 Hillco Leveling System
For Serial Numbers CH7010-12001 thru CH7010-12999

Hydraulic Hoses

LEVELING AND TRIM				
REF.	PART NO.	QTY.	PART NAME	WHERE USED
NS	LA-146841	2	3/8" 100R2 HOSE 9-1/4" #6 FORS X #6 FORS 90°	MAIN ROD TO COUNTERBALANCE VALVE PORT #3 LEFT & RIGHT
NS	LA-146991	2	3/8" 100R2 HOSE 86" #6 FORS 90° X #6 FORS STR	LEVELING PORT "A" TO COUNTERBALANCE VALVE PORT #3 LEFT
NS	LA-146991	1	3/8" 100R2 HOSE 86" #6 FORS 90° X #6 FORS STR	LEVELING PORT "B" TO COUNTERBALANCE VALVE PORT #2 LEFT
NS	LA-146821	1	3/8" 100R2 HOSE 44" #6 FORS X #6 FORS 90°	COUNTERBALANCE VALVE PORT #2 RIGHT TO COUNTERBALANCE VALVE PORT #3 LEFT
NS	LA-146831	1	3/8" 100R2 HOSE 42-1/2" #6 FORS X #6 FORS 90°	COUNTERBALANCE VALVE PORT #3 RIGHT TO COUNTERBALANCE VALVE PORT #2 LEFT
NS	LA-147271	1	1/4" 100R2 HOSE 98" #6 FORS X #6 FORS 90°	MASTER CYLINDER BASE TO SLAVE CYLINDER BASE
NS	LA-147281	1	1/4" 100R2 HOSE 122" #6 FORS X #6 FORS	MASTER CYLINDER ROD TO SLAVE CYLINDER ROD
NS	LA-140592	1	1/4" 100R2 HOSE 90" #8 FORS X #6 FORS	FT "HEAD" PORT TO MASTER BASE
NS	LA-147022	1	1/4" 100R2 HOSE 82" #6 FORS X #6 FORS	FT "ROD" PORT TO MASTER ROD
NS	LA-147161	1	1/4" 100R2 HOSE 18" #6 FORS X #6 FORS	CROSS PORT RELIEF #1 TO "FTP" PORT ON FIELD TRACKER VALVE
NS	LA-146852		1/4" 100R2 HOSE 39" #4 FORS X #4 FORS	LOAD SENSE LINE
NS	LA-146862		5/8" 100R2 HOSE 17" #10 FORS 45 X #10 FORS	LEVELING VALVE PRESSURE HOSE
NS	LA-146872		5/8" 100R2 HOSE 34" #10 FORS 45 X #10 FORS	LEVELING VALVE RETURN HOSE
NS	HC-143581	1	ABRASION SLEEVE, NYLON - 1.22" X 24"	HOSES TO SLAVE CYLINDER
NS	HC-135771	3	1/4-28 MALE X 1/8 FPT 90°	MASTER & LEVELING CYLINDER BASE
NS	HC-135881	1	1/4-28 MALE X 1/8 FPT STR	MASTER CYLINDER ROD
HEADER LIFT CYLINDER HOSES				
NS	LA-147031	2	1/2" 100R2 HOSE 46" #8 FORS 45° X #8 FORS	HEADER LIFT HOSES
NS	HC-143581	2	ABRASION SLEEVE, NYLON - 1.22 ID X 24"	HEADER LIFT HOSES
DROP AXLE				
NS	LA-133331	1	3/16 R1 12" GREASE HOSE 1/8 MPT X 1/8 MPT	REAR AXLE ZERK
GREASE				
NS	LA-133331	2	3/16 R1 12" GREASE HOSE 1/8 MPT X 1/8 MPT	L & R MAIN LEVELING CYLINDER BASE TO LEFT AND RIGHT BULKHEADS
NS	LA-133341	1	3/16 R1 9-1/2" GREASE HOSE 1/8 MPT X 1/8 MPT	MASTER BASE TO RH BULKHEAD
NS	LA-133322	2	3/16 R1 55" GREASE HOSE 1/8 MPT X 1/8 MPT	MASTER ROD TO RH BULKHEAD & MAIN PIVOT PIN TO LH BULKHEAD
BRAKE HOSES				
NS	LA-146951	1	3/8" 100R2 HOSE 106" #6 FORS 90° X #6 FORS	RIGHT BRAKE HOSE TO HOSE 90° END
NS	LA-146961	1	3/8" 100R2 HOSE 106" #6 FORS X #6 FORS	LEFT BRAKE HOSE TO HOSE STR END
NS	LA-142142	1	3/8" 100R2 HOSE 25" #6 FORS 90 X #6 FORS 90	REPLACES STEEL BRAKE LINE LOOP
HYDRO HOSES				
NS	HC-133541	3	ABRASION SLEEVE, NYLON - 2.19 ID X 32"	HYDRO HOSES
STEERING HOSES				
NS	LA-146972	1	3/8" 100R2 HOSE 40" #8 FORS X #8 FORS	BOTTOM STEERING LINE
NS	LA-146982	1	3/8" 100R2 HOSE 40" #8 FORS X #8 MORS	TOP STEERING LINE
FEEDERHOUSE ENGAGE HOSES				
NS	LA-147001	1	3/8" 100R2 HOSE 80" #6 FORS X #8 FORS	C2 PORT ON BRAKE VALVE TO ROD END OF FEEDER ENGAGE CYLINDER
NS	LA-147011	1	3/8" 100R2 HOSE 80" #6 FORS 90 X #6 FORS	C1 PORT ON BRAKE VALVE TO BASE END OF FEEDER ENGAGE CYLINDER
NS	HC-142151	1	ABRASION SLEEVE, NYLON - 1.66 ID X 12"	FEEDER ENGAGE HOSES

Model CH7010 Hillco Leveling System
For Serial Numbers CH7010-12001 thru CH7010-12999

Hydraulic Adapters

LEVELING MANIFOLD				
REF.	PART NO.	QTY.	PART NAME	WHERE USED
NS	HA-M-4FF4MF	1	#4 ORS SWIVEL NUT RUN TEE	"LS" HOSE AT FEEDER VALVE
NS	HA-M-12FF12MF	1	#12 ORS SWIVEL NUT RUN TEE	PRESSURE HOSE AT FEEDER VALVE
NS	HA-S-12FF10MF	1	#12 FORS X #10 MORS STR.	#12 TEE @ FEEDER VALVE
NS	HA-M-16FF16MF	1	#16 ORS SWIVEL NUT RUN TEE	RETURN HOSE AT FEEDER VALVE
NS	HA-S-16FF10MF	1	#16 FORS X #10 MORS STR.	#16 TEE @ FEEDER VALVE
NS	HA-L-8FF8MF	1	#8 FORS X #8 MORS 90 DEG	"HEAD" PORT ON FT VALVE
NS	HA-L-6FF6MF	1	#6 FORS X #6 MORS 90 DEG	"ROD" PORT ON FT VALVE
NS	HA-L-6MF4MO	4	#4 MORB X #6 MORS 90°	#1 AND #2 PORTS IN RELIEF VALVE
NS	HA-L-6MF8MO	2	#6 MORS X #8 MORB 90°	"A" & "B" PORTS
NS	HA-E-10MO	2	#10 MORB SOCKET HEAD PLUG (ZERO-LEAK)	"P" & "T" PORTS
NS	HA-S-10MF10MO	2	#10 MORS X #10 MORB STR	"P" & "T" PORTS
NS	HA-L-10FF10MF	2	#10 FORS X #10 MORS 90°	"P" & "T" PORTS
NS	HA-L-4MF4MO	1	#4 MORS X #4 MORB 90°	LOAD SENSE SHUTTLE
NS	HA-L-8FF8MF	2	#8 FORS X #8 MORS 90°	STEERING CYLINDER PORTS
NS	HA-L-6FF6MF	1	#6 FORS X #6 MORS 90°	LEFT BRAKE PORT ON TRANSMISSION
NS	HA-L-6FF6MF	1	#6 FORS X #6 MORS 90°	FEEDER ENGAGE PORT ON BRAKE VALVE
NS	HA-F-6FF6MF	1	#6 FORS X #6 MORS 45°	BRAKE VALVE PRESSURE PORT
NS	HA-F-16FF16MF	1	#16 FORS X #16 MORS 45°	CASE DRAIN ON HYDRO MOTOR
NS	HA-L-16FF16MF	1	#16 MORS X #16 FORS 90°	CASE DRAIN ON HYDRO PUMP
MAIN CYLINDER AND COUNTERBALANCE VALVE				
NS	HA-L-6MO6MO	2	#6 MORB X #6 MORB 90°	LEFT & RIGHT COUNTERBALANCE VALVE PORT #1 TO MAIN CYL BASE
NS	HA-L-6MF8MO	2	#6 MORS X #8 MORB 90°	LEFT & RIGHT MAIN CYLINDER ROD
NS	HA-S-6FO8MO	2	#8 MORB X #6 FORB STR	LEFT & RIGHT MAIN CYLINDER BASE
NS	HA-Q-6MF6MO	3	#6 MORS STR THREAD BRANCH TEE	LEFT & RIGHT COUNTER BALANCE VALVE PORT #3 AND COUNTERBALANCE #2 LEFT
NS	HA-M-6FF6MF	1	#6 MORS X #6 FORS SWIVEL NUT RUN TEE	LEFT COUNTERBALANCE VALVE PORT #3
NS	HA-L-6MF6MO	1	#6 MORS X # 6 MORB 90°	RIGHT COUNTERBALANCE VALVE PORT #2
MASTER AND SLAVE CYLINDERS				
NS	HA-Q-6MF6MO	2	#6MORS STR THREAD BRANCH TEE	MASTER BASE AND ROD PORTS
NS	HA-L-6MF6MO	1	#6 MORS X #6 MORB 90°	SLAVE ROD PORT
NS	HA-S-6MF6MO	1	#6 MORS X #6 MORB STR	SLAVE BASE PORT
GREASE UNDERCARRIAGE/OVERCARRIAGE				
NS	HA-L-2FP2MP	1	1/8 MPT 90 STREET EL	MAIN PIVOT PIN
NS	HA-S-2MN2FP	5	1/8 NPSM X 1/8 FPT BULKHEAD CONNECTOR	GREASE BULKHEAD CONNECTORS
NS	HA-NJ-2FN	5	1/8 NPSM BULKHEAD LOCKNUT	GREASE BULKHEAD CONNECTORS
NS	HC-138011	5	ZERK, GREASE 1/4-28 STR	ALL GREASE HOSES
GREASE - DROP AXLE				
NS	HA-L-2FP2MP	1	1/8 MPT 90 STREET EL	DROP AXLE MAIN PIVOT PIN
NS	HA-S-2MN2FP	1	1/8 NPSM X 1/8 FPT BULKHEAD CONNECTOR	GREASE BULKHEAD CONNECTORS
NS	HA-NJ-2FN	1	1/8 NPSM BULKHEAD LOCKNUT	GREASE BULKHEAD CONNECTORS
NS	HC-138011	1	ZERK, GREASE 1/4-28 STRAIGHT	ALL GREASE HOSES

Miscellaneous



2 - LL-151061



1 - LL-33741

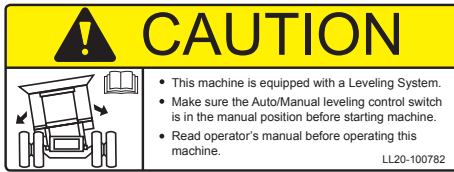

3 - LL20-100782



5 - LL20-100784



4 - LL20-100783



6 - LL20-100787



7 - LL20-100787



8 - LL20-100788



9 - LL-150511

10 - LL150521

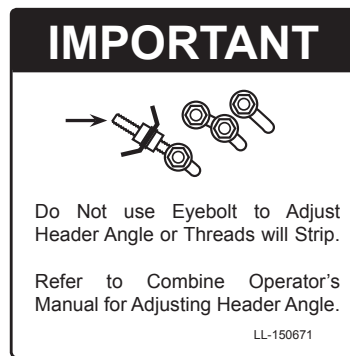

11 - LL150671

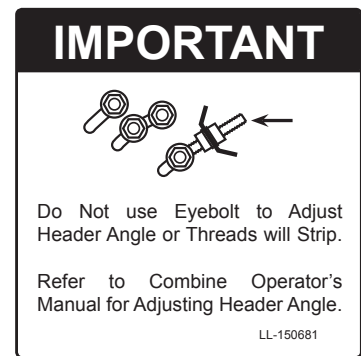

12 - LL150681

Model CH7010 Hillco Leveling System
For Serial Numbers CH7010-12001 thru CH7010-12999

DOCUMENTS AND LABELS				
REF.	PART NO.	QTY.	PART NAME	NOTES
NS	D-050611SLR01	1	WARRANTY REG CARD	SENT WITH OPERATOR'S MANUAL
NS	D-120417CMA01A	1	CH7010 OPERATORS MANUAL	
NS	LA-270031	1	TAG, SERIAL NUMBER 3700S	LEFT REAR OF UNDERCARRIAGE
NS	LL-133741	1	LABEL, GREASE 50 HRS	BY BASE END OF SLAVE CYLINDER
NS	LL-133741	2	LABEL, GREASE 50 HRS	
1	LL-133741	2	LABEL, GREASE 50 HRS	MAIN LEV CYL BOTTOM LEFT & RIGHT
1	LL-133741	2	LABEL, GREASE 50 HRS	BULKHEAD MOUNT LEFT & RIGHT
NS	LL-143621	2	DANGER, AVOID CRUSHING INJURY	REAR OF UNDERCARRIAGE NEAR THE SAFETY STOP MOUNTS
2	LL-151061	2	DECAL, CASE HILLSIDE LEVELING SYSTEM	SIDE PANELS ON COMBINE
3	LL20-100782	1	CAUTION LEVELING SYSTEM CAB	WINDOW IN CAB
4	LL20-100783	2	DANGER, CRUSHING HAZARD	FRONT OF UNDERCARRIAGE LEFT & RIGHT
4	LL20-100783	2	DANGER CRUSHING HAZARD	SIDE OF COMBINE ABOVE REAR TIRES
5	LL20-100784	2	DANGER PINCH POINT	UPPER TRANS FACE PLATE LEFT & RIGHT
6	LL20-100786	1	WARNING ELECTRONIC CRUSHING HAZARD	FRONT OF CONTROL BOX
7	LL20-100787	1	CAUTION LEVELING SYSTEM HAZARD	CLEAN GRAIN ELEVATOR-RIGHT; SCREEN- LEFT
8	LL20-100788	1	HYDRAULIC HAZARD DECAL	ABOVE HYDRAULIC MANIFOLD
8	LL20-100788	2	DANGER HYDRAULIC HAZARD	1- EA MAIN CYLINDERS
NS	LL-239412	1	LABEL, STEERING WHEEL	TIED TO STEERING WHEEL DURING INSTALLATION
NS	LL-274401	1	LIMIT SWITCH WARNING LABEL	INSTALLED ON 1 LIMIT SWITCH
11	LL-150671	1	LABEL, EYEBOLT LEFT	
12	LL150681	1	LABEL, EYEBOLT RIGHT	
MISCELLANEOUS COMPONENTS				
REF.	PART NO.	QTY.	PART NAME	NOTES
NS	HC-143601	2	CLAMP,HOSE 1-1/8" R/C 3/8 HOLE	SLAVE CYLINDER HOSES
NS	HC-139431	6	BEHRINGER TWIN CLAMP .750 DIAMETER	4 - BRAKE & HDR LIFT HOSES ON TOP OF OC; 2 - BRAKE & STEERING HOSES AT AUGER BED
NS	HC-139451	3	BEHRINGER TWIN COVER PLATE (FOR .750)	2 - BRAKE HOSES ON TOP OF OC; 1 - BRAKE & STEERING HOSES AT AUGER BED
NS	HC-139461	1	BEHRINGER TWIN BOLT (FOR .750)	LEFT HDR LIFT HOSE CLAMP ON TOP OF OC
NS	HC-139471	2	BEHRINGER STACK BOLT (FOR .750)	BRAKE HOSES ON TOP OF OC
NS	F-HC-08M100F	1	HC-8.8 M8 X 1.25 X 100	HOSE CLAMPS FOR BRAKE & STEERING HOSES
NS	F-HNF-08ME	1	FLHN-10.9 M8 X 1.25 PLT	HOSE CLAMPS FOR BRAKE & STEERING HOSES
NS	F-HCF-08M020E	2	FLHC-10.9 M8 X 1.25 X 20 PLT	HOSE CLAMPS FOR SLAVE CYL HOSES
NS	F-HNF-08ME	2	FLHN-10.9 M8 X 1.25 PLT	HOSE CLAMPS FOR SLAVE CYL HOSES
NS	F-HCF-16M040E	2	FLHC-10.9 M16 X 2.00 X 40	HANDLE TO HEADER LOCK MECHANISM
NS	F-HNF-16ME	2	FLHN-10.9 M16 X 2.00	HANDLE TO HEADER LOCK MECHANISM

Model CH7010 Hillco Leveling System
For Serial Numbers CH7010-12001 thru CH7010-12999

Hillco Technologies, Inc.
107 1st Avenue
Nezperce, Idaho 83543

Phone	800-937-2461
	208-937-2461
Fax	208-937-2280

www.hillcotechnologies.com
email: support@hillcotechnologies.com