

Model JS9010 Hillco Leveling System
For Serial Numbers JS9010-16001 thru JS9010-16999



Model JS9010 Sidehill Leveling System Parts Manual

SN JS9010-16001 thru JS9010-16999

For John Deere S680 & S690
S Series Combines

D-120618CMA01D



JS9010 Sidehill Leveling System

For S680 & S690 S-Series Combines

Table of Contents

General Information	3
Serial Number Location	3
Text and Illustrations	3
Abbreviations	3
Right and left Identification	3
Part Orders	3
Transition	4
Tilt Sensor	5
Feeder Drum Arms and Chain Extensions	6
Transition Throat	8
Transition Throat - Hydraulic Fore/Aft	10
Transition Header Adapter	12
Transition Header Adapter - Hydraulic Fore/Aft	14
Carriage	16
Overcarriage	17
Undercarriage	19
Carriage Misc. Parts	21
Carriage Position Sensor	22
Drop Axle	24
Hydraulic Components	25
Leveling Manifold	26
Header Trim Manifold	28
John Deere Header Lift Manifold	29
Hydraulic Hoses	31
Retractable Ladder	32
Single Step Retractable Ladder	32
Double Step Retractable Ladder	34
Ladder Wedge	36
Electrical	38
Controller/Wiring Harnesses	38
Decals and Literature	39

Contact Information

Hillco Technologies, Inc. 107 1st Avenue Nezperce, Idaho 83543	Phone 800-937-2461 208-937-2461
	Fax 208-937-2280
www.hillcotechnologies.com email: support@hillcotechnologies.com	

GENERAL INFORMATION

SERIAL NUMBER LOCATION

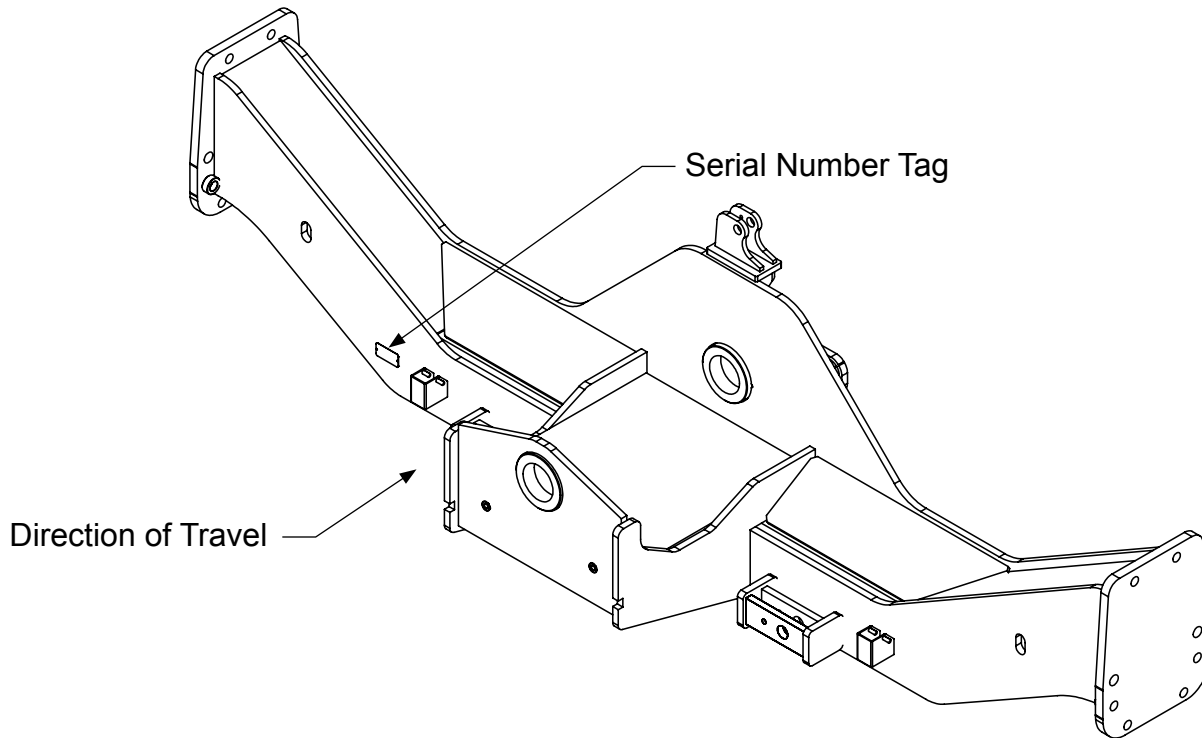

TEXT AND ILLUSTRATIONS

The arrangement of this parts catalog is for easy identification of parts. All parts are illustrated in exploded views in proper relation to each other. Some diagrams refer to other pages for further information. Reference numbers used in the illustrations refer to line numbers in the part lists. The part lists appear to the right or below all diagrams and correspond with those diagrams. Included in the part lists, along with the reference numbers are part numbers, part descriptions and the quantity of the part required per leveling system.

ABBREVIATIONS

SN “Serial Number” refers to the serial number given to each leveling system (by Hillco Technologies), as well as the serial number given to the combine (by the specific combine manufacturer) the leveling system is installed. See above for the leveling system’s serial number location. This abbreviation is used interchangeably in both instances. Each Model JS9010 Leveling System uses the following serial number format: JS9010-XXXXX (sequential numbers).

ASM “Assembly” refers to a whole grouping of parts (shown in the diagram corresponding with the page where “ASM” is shown unless otherwise noted). Some assemblies have parts that are sold separately, however some must be purchased as a single unit. Hillco Product Specialists will be able to assist you with any questions.

NS “Not Shown” refers to a part that is not depicted in the illustration.

RIGHT AND LEFT IDENTIFICATION

The reference to right-hand and left-hand in this catalog is identified by the operator sitting in the operator’s seat, looking toward the front of the machine (in normal forward travel).

PART ORDERS

Orders must specify product model, serial number, correct part number, complete description, quantity required, method of shipment, shipping address, and billing address.

TRANSITION

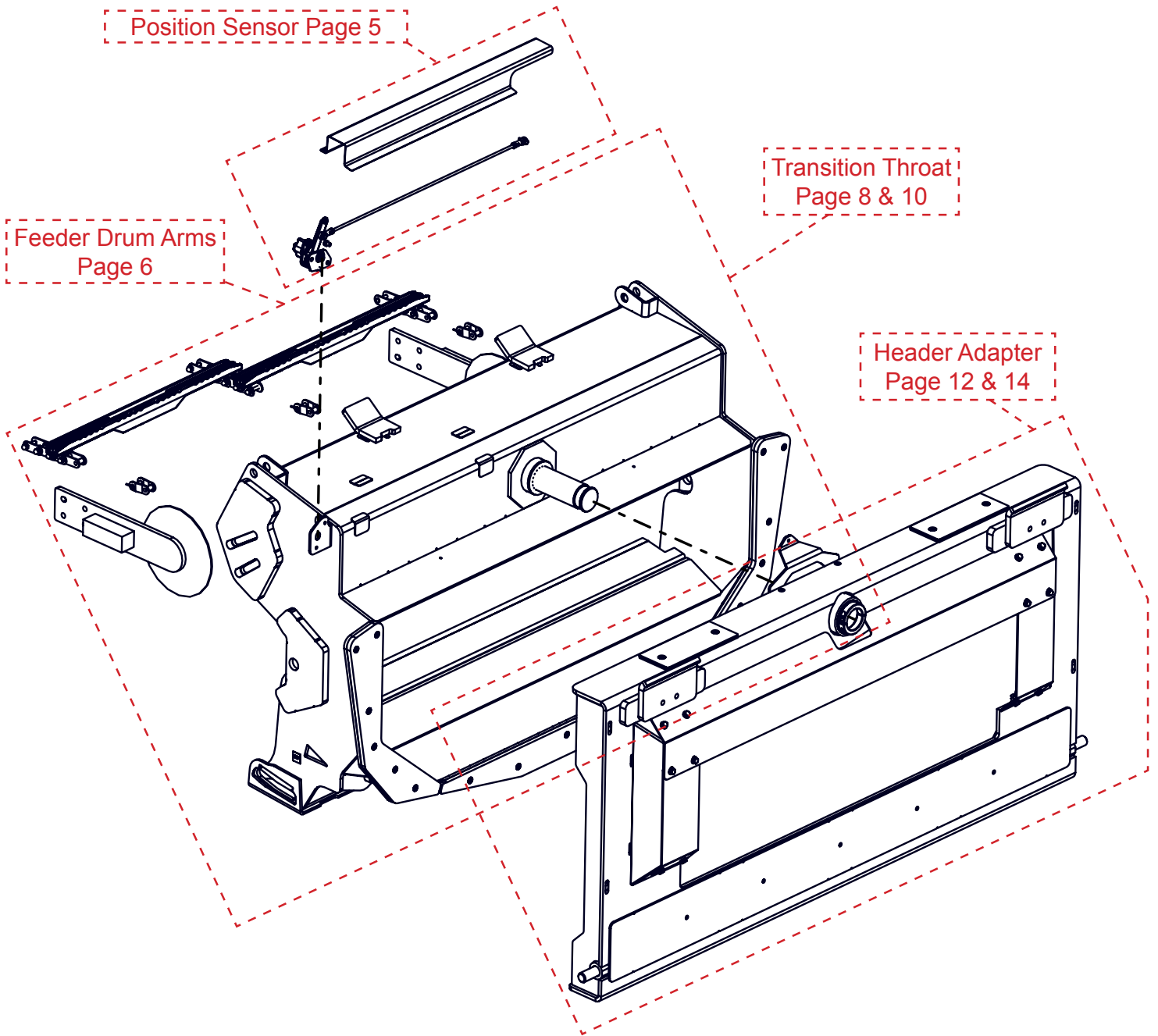

Model JS9010 Hillco Leveling System
 For Serial Numbers JS9010-16001 thru JS9010-16999

TRANSITION TILT SENSOR

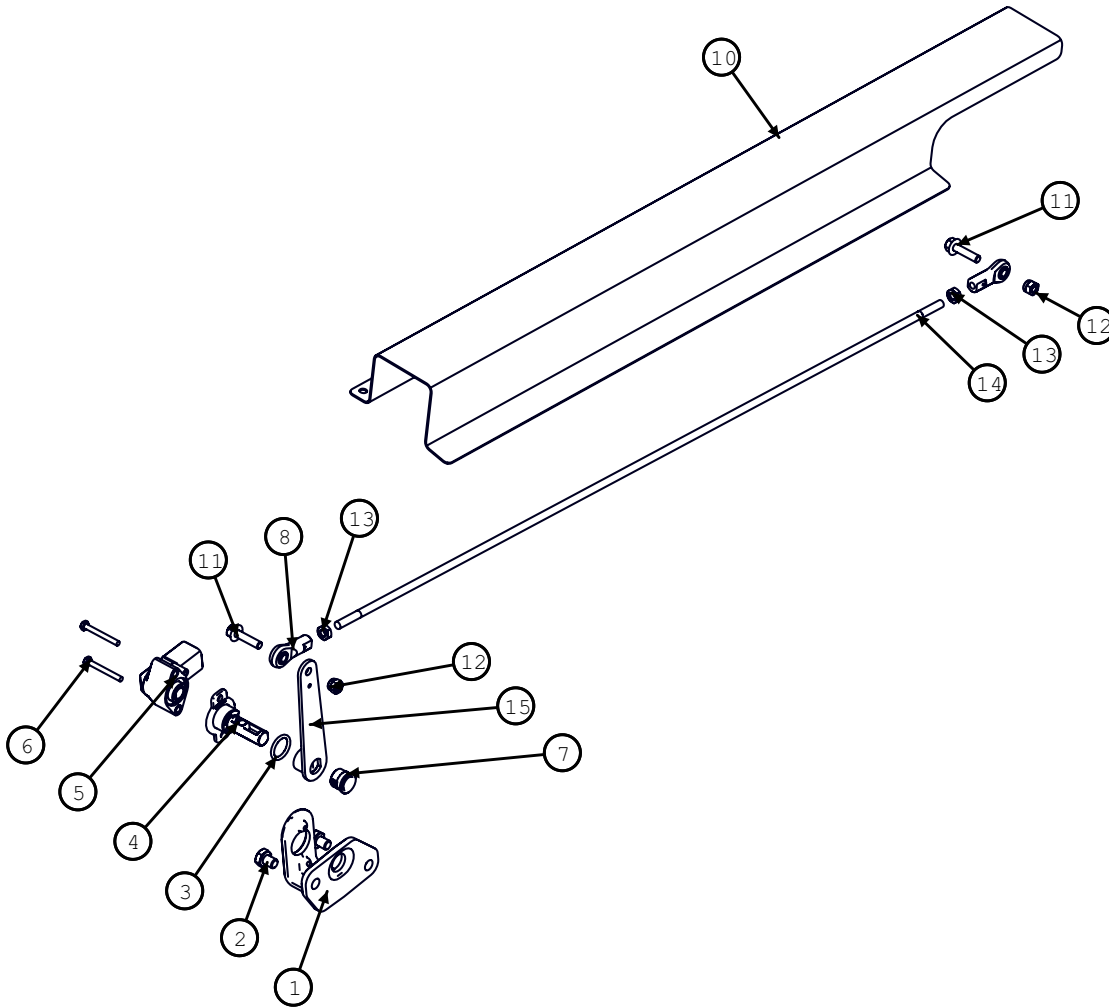

TRANSITION POSITION SENSOR			
BOM ID	Part No.	Qty	Description
1	151321	1	BRACKET, SENSOR
2	178.008	2	BOLT,HX,CL8.8 M8X10
3	151391	1	O-RING, 11/16 ID
4	151401	1	SENSOR SHAFT,
5	151381	1	SENSOR, ROTATION,
6	170.004	2	BOLT, HX,CL8.8
7	151361	1	BUSHING,
8	151881	2	ROD END, BALL JOINT,
9	201.006	1	PIN,ROLL M6X36
10	1295541	1	SENSOR LINKAGE
11	122.006	2	BOLT,HX,FL,CL10.9 M6X25
12	191.006	2	NUT,HX,NYL,CL8 M6
13	184.004	2	NUT,HX,JAM,GR5 1/4-28
14	1295502	1	SENSOR ROD
15	151371	1	ARM, TILT SENSOR

Feeder Drum Arms and Chain Extensions

10" Drum, 3 Strand

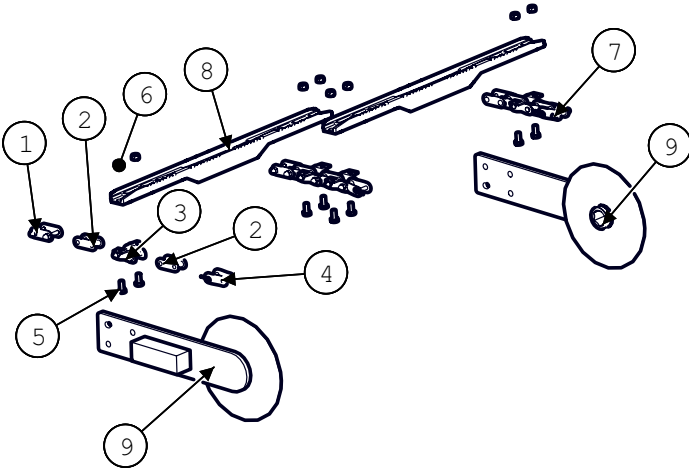

8" Drum, Full Travel, Hydraulic Fore/Aft

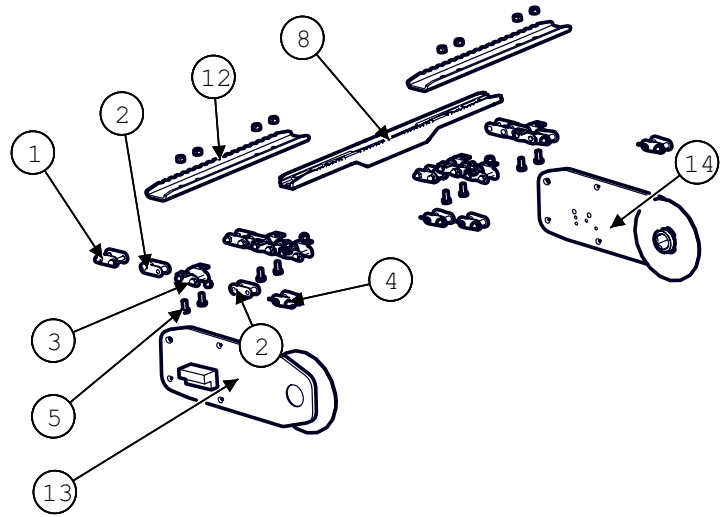

8" Drum, Limited Travel

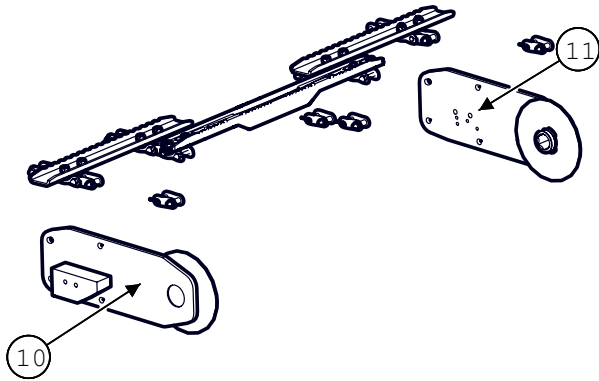

8" Drum, Full Travel

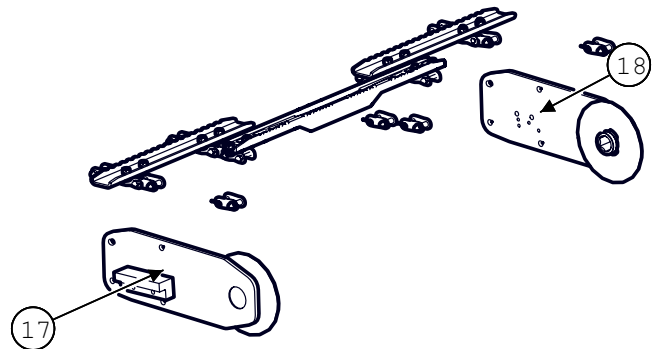

8" Drum, Limited Travel, Hydraulic Fore/Aft

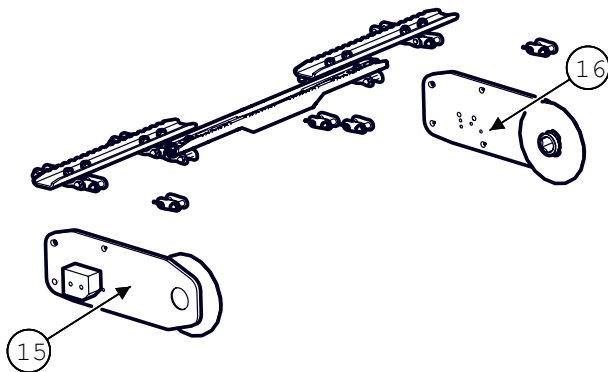

Model JS9010 Hillco Leveling System
For Serial Numbers JS9010-16001 thru JS9010-16999

Feeder Drum Arms & Feeder Chain			
10" DRUM, 3-STRAND,			
BOM ID	Part No.	Qty	Description
140261	1	3	COUPLER, CA557 CHAIN LINK
146391	2	6	LINK, FEMALE, CA557
146381	3	4	CHAIN LINK WITH K6 SIDEBAR
146641	4	3	LINK, OFFSET COUPLER CA557
120.010.020	5	10	BOLT,HX,CL10.9 M10
126.01	6	10	NUT,HX,STV,CL10 M10
146211	7	3	NUT 8MM X 1.25 ACORN
146402	8	2	SLAT, CAST
1269141	9	2	10" FEEDR DRUM ARM
8" DRUM, LIMITED TRAVEL			
140261	1	4	COUPLER, CA557 CHAIN LINK
146391	2	8	LINK, FEMALE, CA557
146381	3	6	CHAIN LINK WITH K6 SIDEBAR
146641	4	4	LINK, OFFSET COUPLER CA557
120.010.020	5	12	BOLT,HX,CL10.9 M10
126.01	6	12	NUT,HX,STV,CL10 M10
146211	7	6	NUT 8MM X 1.25 ACORN
146402	8	3	SLAT, CAST
1324681	10	1	8" DRUM ARM, LIMITED TRAVEL
1324671	11	1	8" DRUM ARM, LIMITED TRAVEL
155308	12	2	SHORT CONVEYOR
8" DRUM, FULL TRAVEL, HYDRAULIC FORE/AFT			
140261	1	4	COUPLER, CA557 CHAIN LINK
146391	2	8	LINK, FEMALE, CA557
146381	3	6	CHAIN LINK WITH K6 SIDEBAR
146641	4	4	LINK, OFFSET COUPLER CA557
120.010.020	5	12	BOLT,HX,CL10.9 M10
126.01	6	12	NUT,HX,STV,CL10 M10
146211	7	6	NUT 8MM X 1.25 ACORN
146402	8	3	SLAT, CAST
155308	12	2	SHORT CONVEYOR
1319641	13	1	8" DRUM ARM, FULL TRAVEL, HYDRAULIC FORE/AFT
1319631	14	1	8" DRUM ARM, FULL TRAVEL, HYDRAULIC FORE/AFT
8" DRUM, LIMITED TRAVEL, HYDRAULIC FORE/AFT			
140261	1	4	COUPLER, CA557 CHAIN LINK
146391	2	8	LINK, FEMALE, CA557
146381	3	6	CHAIN LINK WITH K6 SIDEBAR
146641	4	4	LINK, OFFSET COUPLER CA557
120.010.020	5	12	BOLT,HX,CL10.9 M10
126.01	6	12	NUT,HX,STV,CL10 M10
146211	7	6	NUT 8MM X 1.25 ACORN
146402	8	3	SLAT, CAST
155308	12	2	SHORT CONVEYOR
1324841	15	1	8" DRUM ARM, LIMITED TRAVEL, HYDRAULIC FORE/AFT
1324831	16	1	8" DRUM ARM, LIMITED TRAVEL, HYDRAULIC FORE/AFT
8" DRUM, FULL TRAVEL			
140261	1	4	COUPLER, CA557 CHAIN LINK
146391	2	8	LINK, FEMALE, CA557
146381	3	6	CHAIN LINK WITH K6 SIDEBAR
146641	4	4	LINK, OFFSET COUPLER CA557
120.010.020	5	12	BOLT,HX,CL10.9 M10
126.01	6	12	NUT,HX,STV,CL10 M10
146211	7	6	NUT 8MM X 1.25 ACORN
146402	8	3	SLAT, CAST
155308	12	2	SHORT CONVEYOR
1324711	17	1	8" DRUM ARM, FULL TRAVEL
1324701	18	1	8" DRUM ARM, FULL TRAVEL

Model JS9010 Hillco Leveling System
For Serial Numbers JS9010-16001 thru JS9010-16999

TRANSITION THROAT

Front

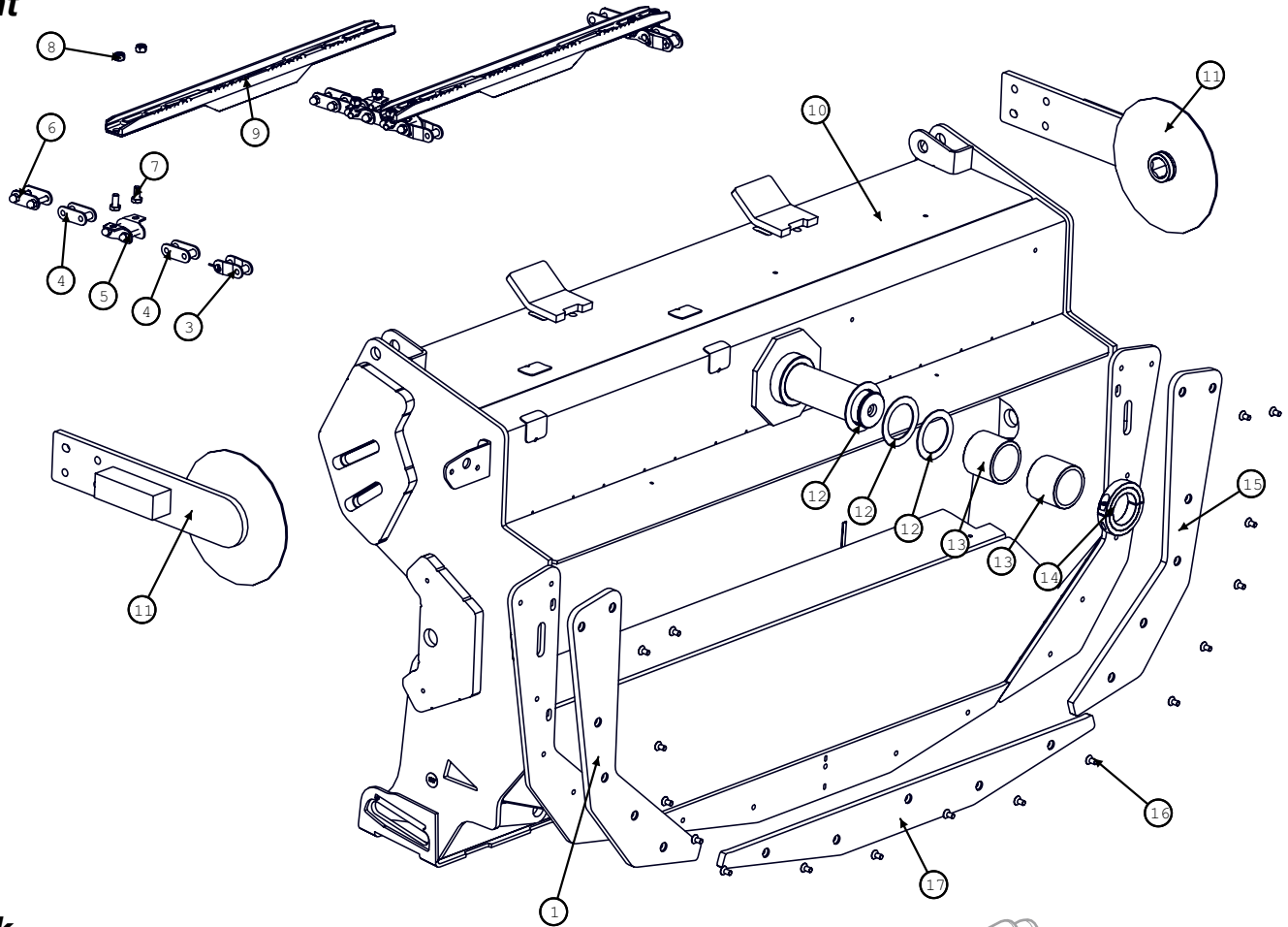

Back

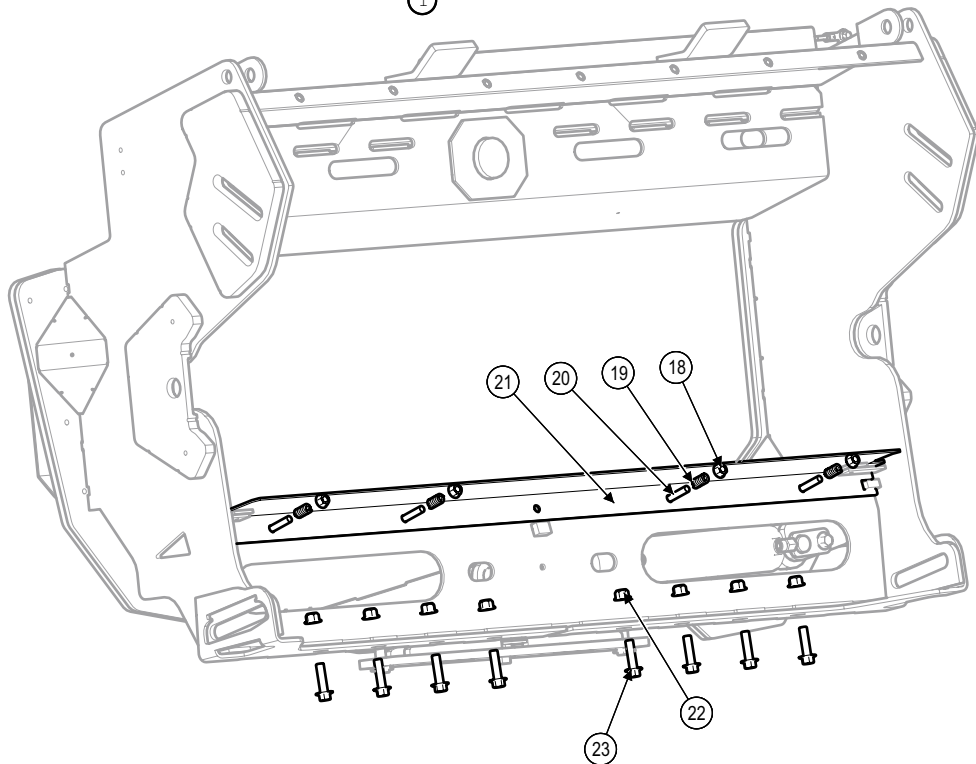

Model JS9010 Hillco Leveling System
For Serial Numbers JS9010-16001 thru JS9010-16999

Transition Throat			
BOM ID	Part No.	Qty	Description
1	1250571	1	RIGHT WEARPAD
3	146641	3	LINK, OFFSET COUPLER CA557
4	146391	6	LINK, FEMALE, CA557
5	146381	4	CHAIN LINK WITH K6 SIDEBAR
6	140261	3	COUPLER, CA557 CHAIN LINK
7	120.01	8	BOLT,HX,CL10.9 M10
8	126.01	8	NUT,HX,STV,CL10 M10
9	146402	2	SLAT, CAST (See previous pages for more slat options)
10	1290461	1	THROAT, SIDEHILL
11	1269141	2	FEEDR DRUM ARM (10" - See previous pages for more drum arm options)
12	162.014.040	3	BUSHING,MACH,NR
13	10133.06.00040	2	TM, GRAPHITE MICARTA
14	150742	1	COLLAR,CLAMPING,2-1/2 ID 3-3/4 OD, 2 PIECE HEAVY
15	1250561	1	LEFT WEARPAD
16	164.008	17	SCREW,FHSC,CL10.9 M8X16
17	1250581	1	BOTTOM WEARPAD
18	125.01	4	NUT,HX,NYL,CL10 M10
19	143591	4	SPRING, COMPRESSION
20	163.010.060	4	BOLT,CARR,CL8.8 M10
21	1313751	1	FLEX FLOOR
22	128.012	8	NUT,HX,FL,STV,CL10 M12
23	122.012.045	8	BOLT,HX,FL,CL10.9 M12X45

Model JS9010 Hillco Leveling System
For Serial Numbers JS9010-16001 thru JS9010-16999

TRANSITION THROAT - HYDRAULIC FORE/AFT

Front

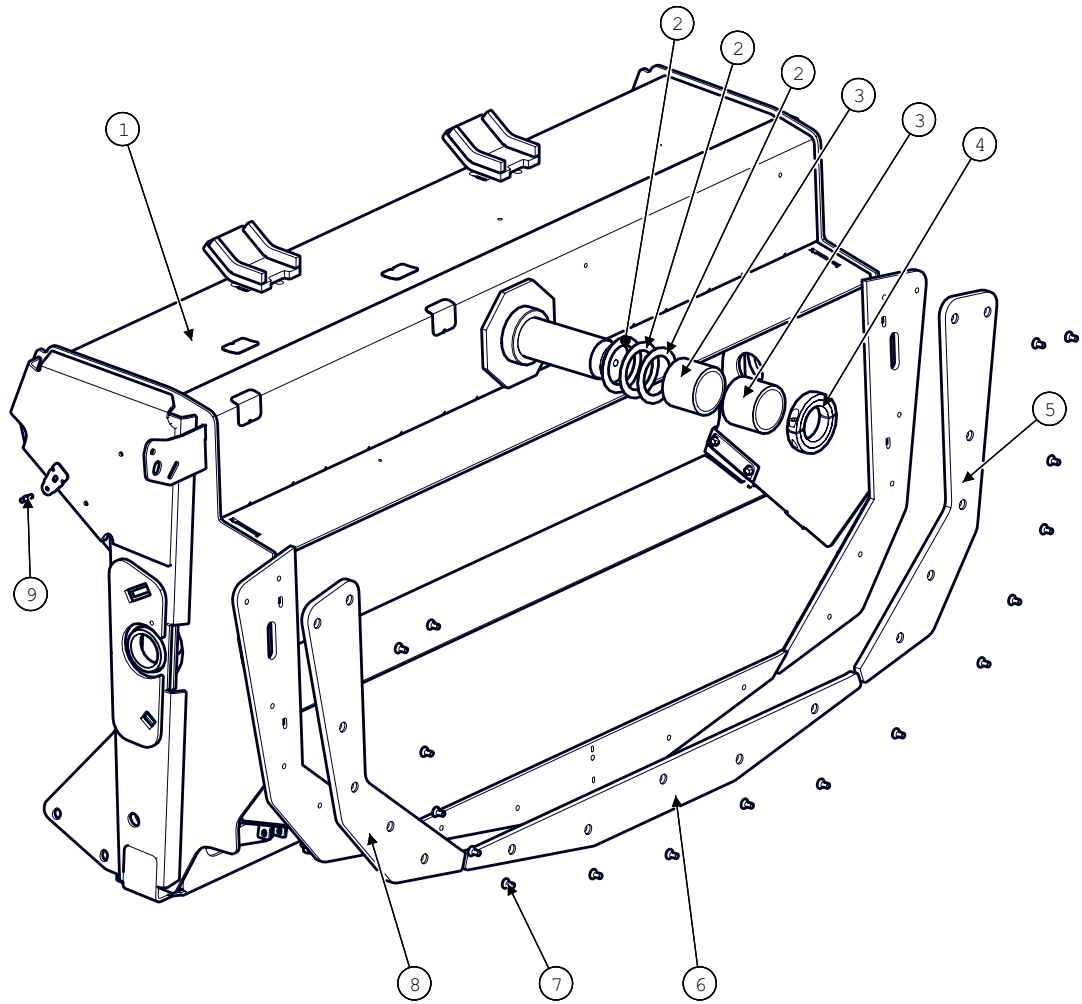

Back

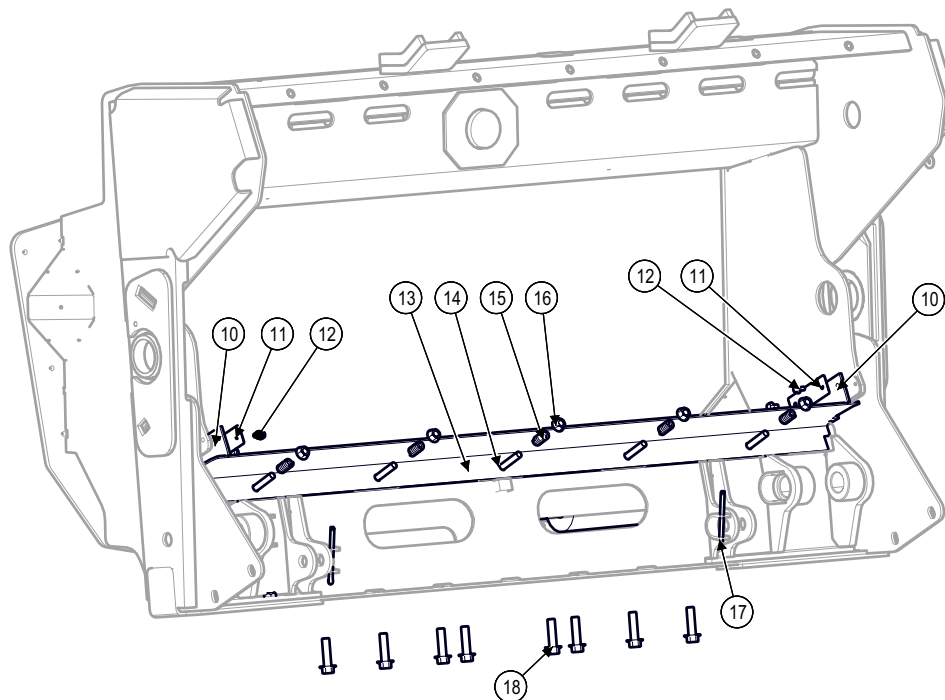

Model JS9010 Hillco Leveling System
For Serial Numbers JS9010-16001 thru JS9010-16999

Transition Throat - Hydraulic Fore/Aft			
BOM ID	Part No.	Qty	Description
1	1318241	1	THROAT, SIDEHILL
2	162.014.040	3	BUSHING,MACH,NR
3	10133.06.00040	2	TM, GRAPHITE MICARTA
4	150742	1	COLLAR,CLAMPING,2-1/2 ID 3-3/4 OD, 2 PIECE HEAVY
5	1250561	1	LEFT WEARPAD
6	1250581	1	BOTTOM WEARPAD
7	164.008.016	17	SCREW,FHSC,CL10.9 M8X16
8	1250571	1	RIGHT WEARPAD
9	151341	1	BALL STUD
10	1323251	2	SEAL
11	1323241	2	STIFFENER, SEAL
12	122.006.012	3	BOLT,HX,FL,CL10.9 M6X12
13	1318882	1	FLEX FLOOR
14	163.010.060	5	BOLT,CARR,CL8.8 M10
15	143591	5	SPRING, COMPRESSION
16	125.01	5	NUT,HX,NYL,CL10 M10
17	142.004.048	2	PIN,COTTER 1/4
18	122.012.04	9	BOLT,HX,FL,CL10.9 M12X4

TRANSITION HEADER ADAPTER

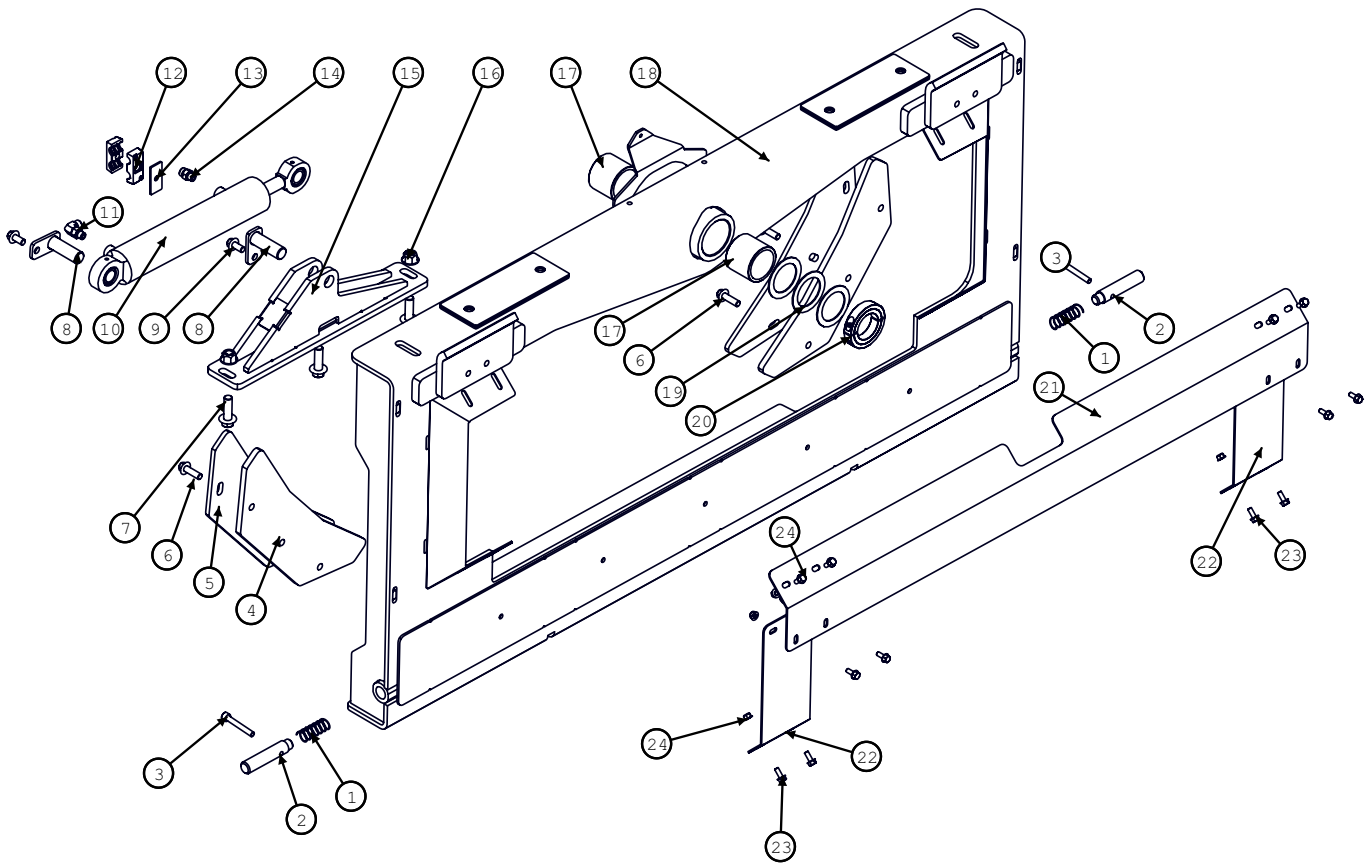

Model JS9010 Hillco Leveling System
For Serial Numbers JS9010-16001 thru JS9010-16999

Transition Header Adapter			
BOM ID	Part No.	Qty	Description
1	135531	2	SPRING, COMPRESSION
2	1229193	2	LOCKOUT PIN
3	195.010.070	2	SCREW,SHC,CL10.9 M10X70
4	1250551	2	BACKING WEARPAD
5	1250541	2	BACKING PLATE
6	122.012.040	6	BOLT,HX,FL,CL10.9 M12X40
7	122.016.050	3	BOLT,HX,FL,CL10.9,M16X50
8	1253883	2	CYLINDER PIN
9	122.012.025	2	BOLT,HX,FL,CL10.9 M12X25
10	138582	1	CYLINDER 2-1/2 X 10
11	1003.06.06	1	-6MORB X -6MORFS
12	139431	2	CLAMP, 3/4" TWIN BEHRINGER PAIR
13	139451	1	COVER PLATE,TWIN
14	1001.06.06	1	HEADER ADAPTER, STR
15	1250713	1	SLAVE CYL ROD MOUNT
16	128.016	2	NUT,HX,FL,STV,CL10 M16
17	10133.06.00040	2	TM, GRAPHITE MICARTA
18	1320921	1	HEADER ADAPTER
19	162.014.040	3	BUSHING,MACH,NR
20	150742	1	COLLAR, CLAMPING
21	1250522	1	TOP SHIELD
22	1250534	2	SIDE SHIELD
23	122.008.020	12	BOLT,HX,FL,CL10.9 M8X20
24	128.008	12	NUT,HX,FL,STV,CL10 M8

TRANSITION HEADER ADAPTER - HYDRAULIC FORE/AFT

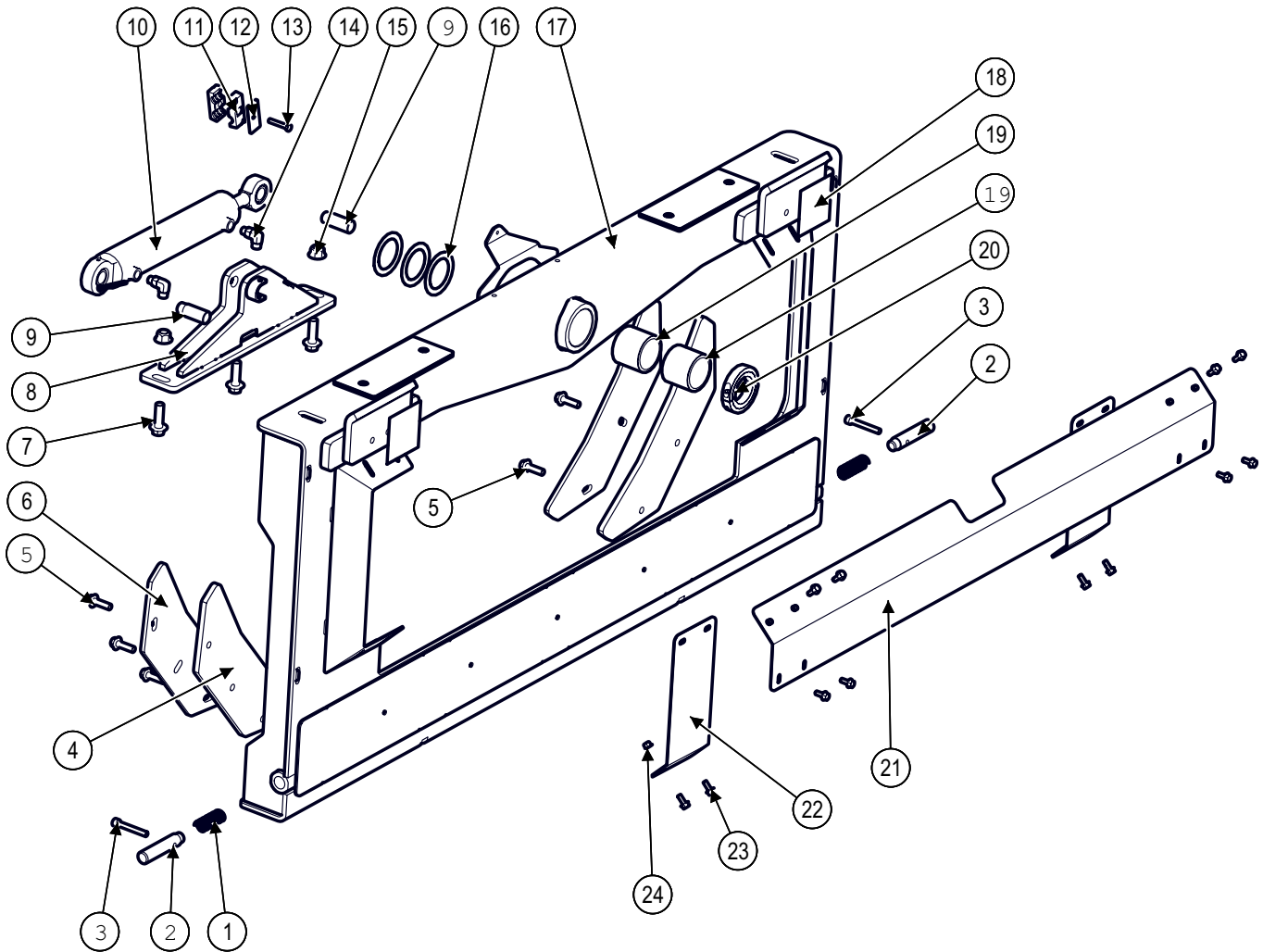

Model JS9010 Hillco Leveling System
For Serial Numbers JS9010-16001 thru JS9010-16999

Transition Header Adapter - Hydraulic Fore/Aft			
BOM ID	Part No.	Qty	Description
1	135531	2	SPRING, COMPRESSION
2	1229193	2	LOCKOUT PIN
3	195.010.070	2	SCREW,SHC,CL10.9 M10X70
4	1250551	2	BACKING WEARPAD
5	122.012.040	6	BOLT,HX,FL,CL10.9 M12X40
6	1250541	2	BACKING PLATE
7	122.016.050	3	BOLT,HX,FL,CL10.9,M16X50
8	1320941	1	CYLINDER MOUNT,
9	1320891	2	PIN, 1" X 2-1/2
10	138582	1	CYLINDER 2-1/2 X 10
11	139431	1	CLAMP, 3/4" TWIN BEHRINGER PAIR
12	139451	1	COVER PLATE,TWIN
13	170.008.045	1	BOLT,HX,CL8.8 M8X45
14	1003.06.06	2	-6MORB X -6MORFS
15	128.016	2	NUT,HX,FL,STV,CL10 M16
16	162.014.040	3	BUSHING,MACH,NR
17	1320921	1	HEADER ADAPTER
18	100784	2	LABEL, PINCH POINT
19	10133.06.00040	2	TM, GRAPHITE MICARTA
20	150742	1	COLLAR,CLAMPING,2-1/2 ID 3-3/4 OD, 2 PIECE HEAVY
21	1250522	1	TOP SHIELD
22	1250534	2	SIDE SHIELD
23	122.008.020	12	BOLT,HX,FL,CL10.9 M8X20
24	128.008	12	NUT,HX,FL,STV,CL10 M8

Model JS9010 Hillco Leveling System
For Serial Numbers JS9010-16001 thru JS9010-16999

Carriage

Overcarriage
Page 17

Carriage
Position Sensor
Page 22

Misc.
Carriage
Parts
Page 21

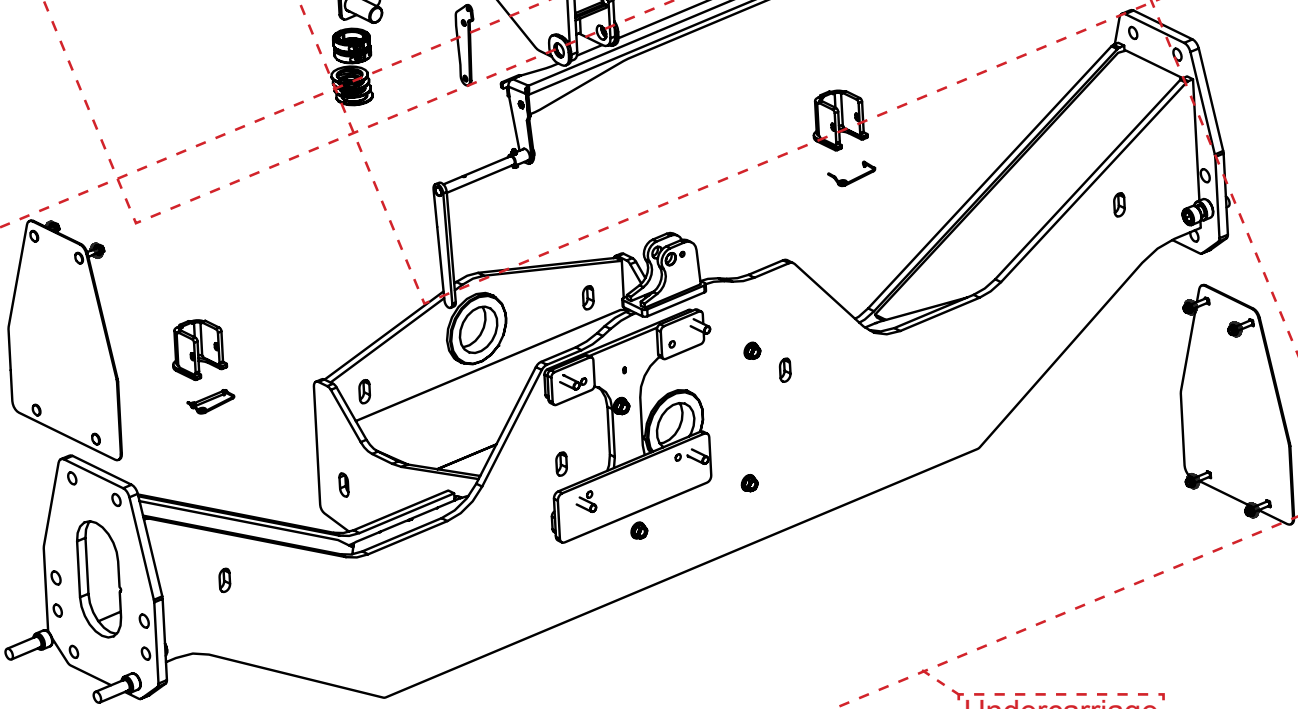
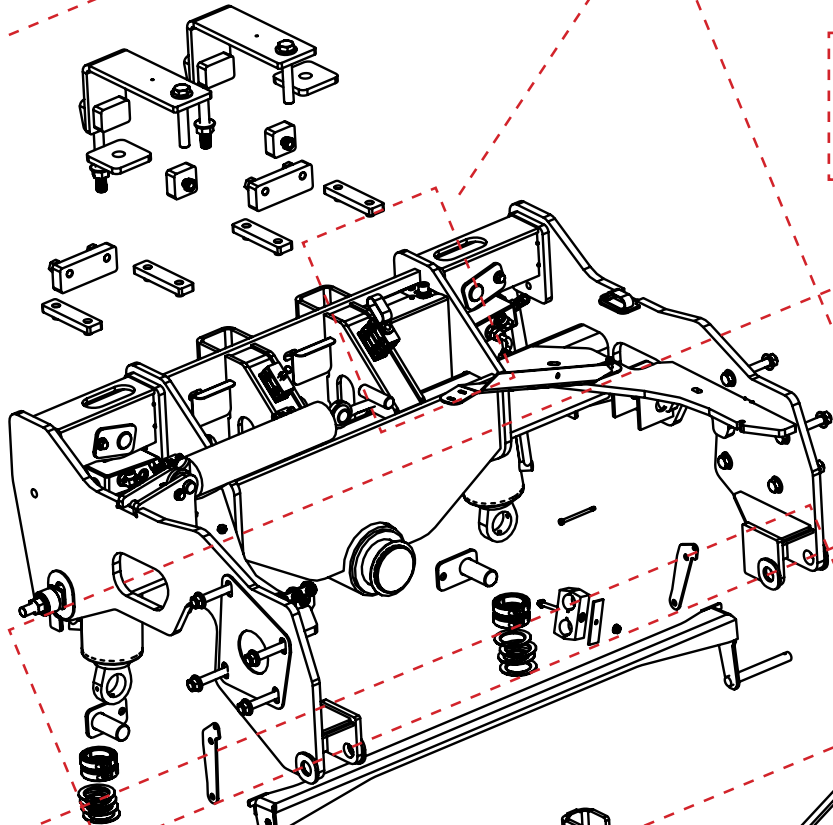

Undercarriage
Page 19

Model JS9010 Hillco Leveling System
For Serial Numbers JS9010-16001 thru JS9010-16999

Overcarriage

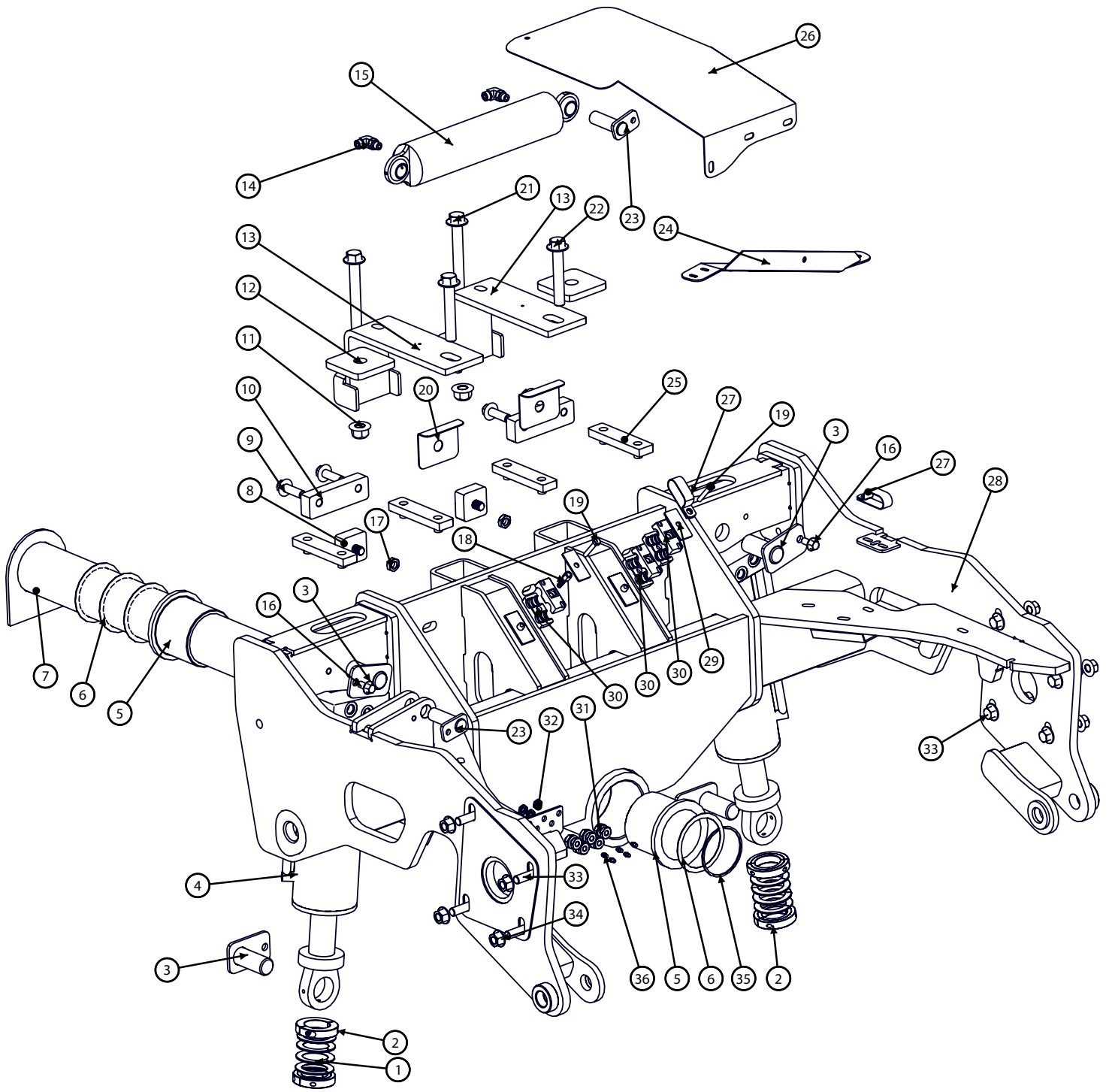

Model JS9010 Hillco Leveling System
For Serial Numbers JS9010-16001 thru JS9010-16999

Overcarriage			
BOM ID	Part No.	Qty	Description
1	137501	8	WASHER, QUICK REPAIR
2	153241	4	COLLAR, CLAMPING
3	1230552	4	PIN, MAIN CYLINDER
4	151002	2	CYLINDER, CB VALVE,
5	1247961	2	PIVOT BUSHING
6	138641	4	4.016ID X 4.7640D X 048
7	1291351	1	PIVOT PIN
8	1296581	2	UPPER CARRIAGE SHIM
9	122.016.050	4	BOLT,HX,FL,CL10.9,M16X50
10	1291731	2	CARRIAGE LOCK (9010)
11	128.02	2	NUT,HX,FL,STV,CL10 M20
12	1297901	2	SPACER, TUBE CLAMP
13	1293631	2	AXLE CLAMP
14	1009.06	2	STR THD, BRANCH,
15	140342	1	CYLINDER, CROSS PORT
16	122.012.025	2	BOLT,HX,FL,CL10.9 M12X25
17	165.016	2	NUT,HX,JAM,CL8 M16
18	139471	1	STACK BOLT, BEHRINGER
19	101.005.032	2	BOLT,HX,GR5 5/16-18X2
20	1270042	2	CARRIAGE SHIM
21	122.020.220	2	BOLT,HX,FL,CL10.9 M20
22	122.020.120	2	BOLT,HX,FL,CL10.9 M20
23	1229071	2	CYLINDER PIN, TRIM
24	1274901	1	SUPPORT, HYDRO HOSE
25	1293561	4	LOWER CARRIAGE SHIM
26	1274252	1	TABLE, HYDRO HOSE
27	147781	2	CLAMP 1/4" DOUBLE LOOP 3/8HOLE
28	1291332	1	OVERCARRIAGE
29	139451	2	COVER PLATE,TWIN
30	139431	3	CLAMP, 3/4" TWIN BEHRINGER PAIR
31	155157	5	BULKHEAD,GREASE,STR,
32	155158	5	BULKHEAD,LOCKNUT
33	122.016.060	8	BOLT, HX, FL, CL10.9, M16X60
34	123.016	8	NUT,HX,FL,CL10 M16
35	138651	1	SNAP RING; 4"
36	138011	5	ZERK,STR, 1/4-28MTAPER

Undercarriage

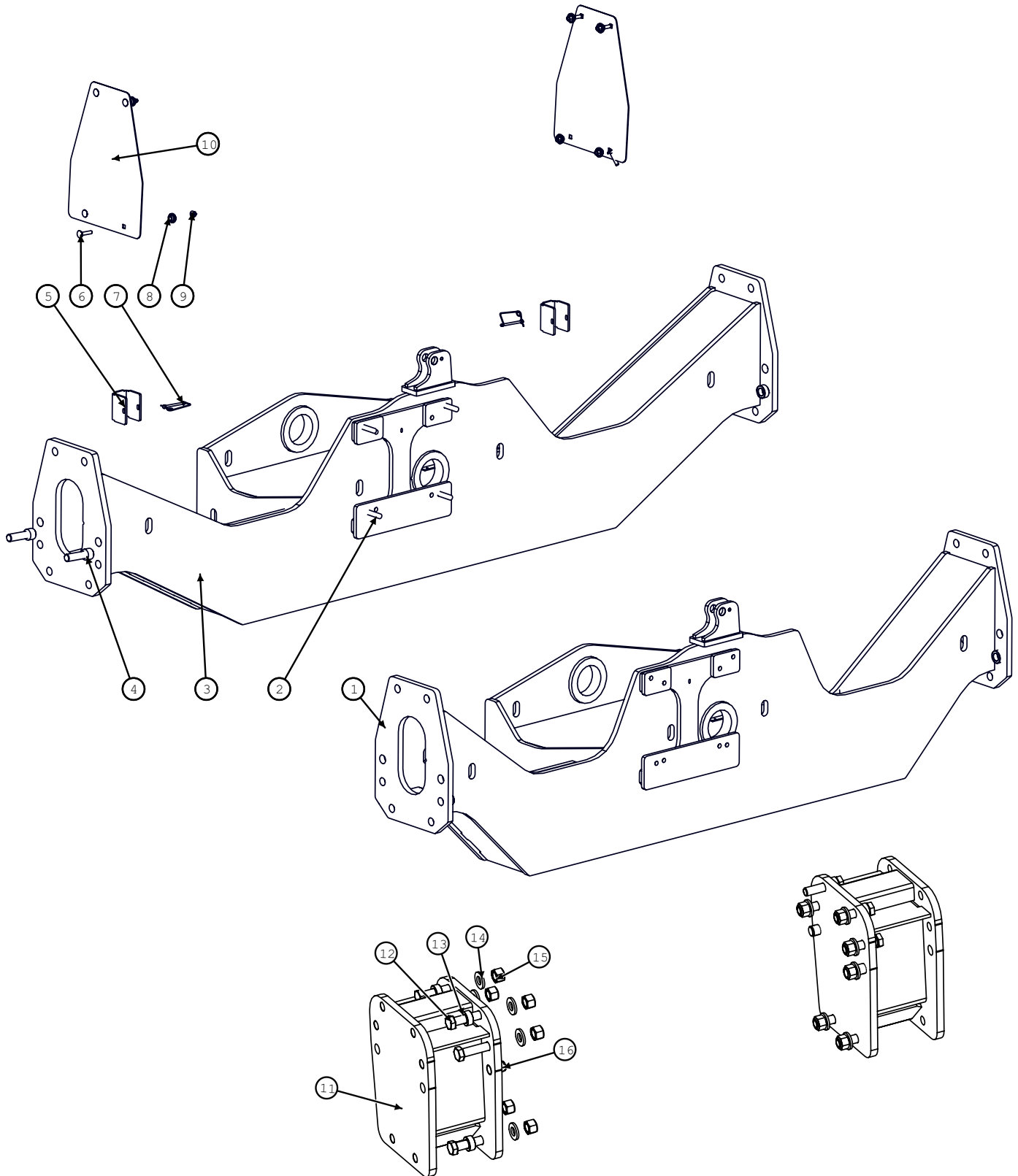

Model JS9010 Hillco Leveling System
For Serial Numbers JS9010-16001 thru JS9010-16999

Undercarriage			
BOM ID	Part No.	Qty	Description
1	1292921	1	UNDERCARRIAGE, NARROW, 96.25",
2	155.016	4	STUD, DOUBLE-10.9
3	1290811	1	UNDERCARRIAGE, WIDE, 114.75"
4	159.024.080	2	SCREW,SHC,CL12.9 M24
5	1307161	2	CYLINDER STOP
6	163.010.050	7	BOLT,CARR,CL8.8 M10
7	146.004.048	2	PIN,SNAP,LCK
8	151021	8	BUSHING, PLASTIC
9	123.01	8	NUT,HX,FL,CL10 M10
10	1293831	2	CAP, AXLE
11-16	LA-253141	1	NARROW UNDERCARRIAGE AXLE EXTENSIONS
11	LA-253132	2	LM WLD, 9.25 AXLE EXTENSION
12	F-HC-24M100E	12	M24 X 3 X 110 HEX CAP
13	LM-266382	8	CU TM, SPACER-FINAL DRIVE
14	MC-141121	12	FW M25.4 X 50.0 X 6.0
15	F-HNS-24ME	12	STOVER NUT 24MX3
16	LM-253871	4	LM RND, DOWEL

Model JS9010 Hillco Leveling System
For Serial Numbers JS9010-16001 thru JS9010-16999

Carriage Misc. Parts

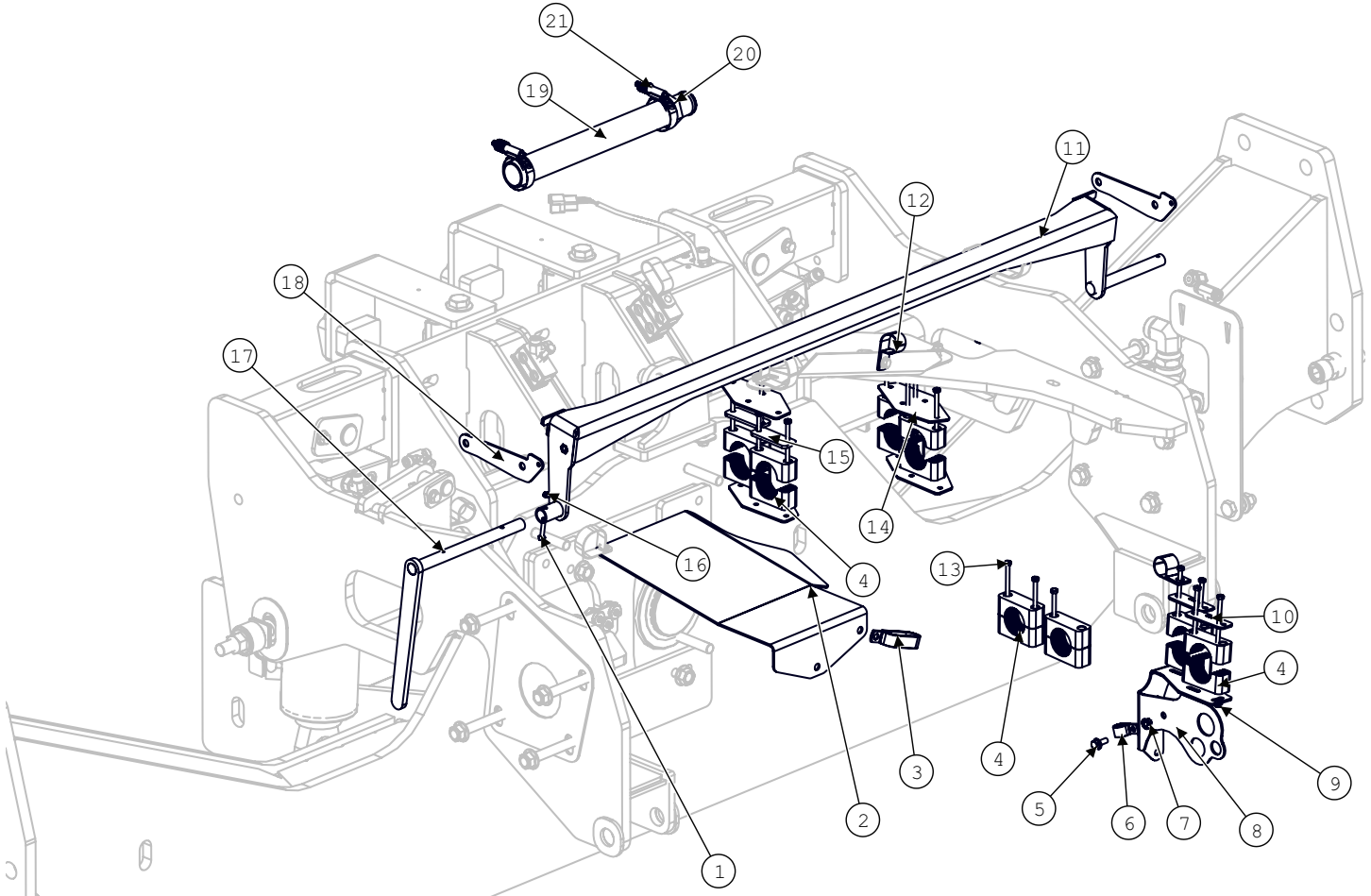

Overcarriage Misc.			
BOM ID	Part No.	Qty	Description
1	121.006.035	1	HC-10.9 M6x1.0X35
2	1274252	1	HM PLT, TABLE HYDRO HOSE
3	1151781	1	CLAMP, P-STYLE (JD#AH77884)
4	140641	8	CLAMP, 2" BEHRINGER STD
5	179.008.025	1	FLHC-10.9M8X1.25X20
6	135791	1	CLAMP, HOSE 7/8 R/C W 3/8HOLE (JD#AH78237)
7	123.008	1	FLHN-10.9M8X1.25
8	1297312	1	LM WLD, HYDRO HOSE SUPPORT
9	F-HNF-06ME	4	FLHN-10.9M6X1.00
10	140651	2	BEHRINGER STD COVER PLATE
11	1264511	1	LM ASM, LINKAGE, ROCK TRAP
12	143601	2	CLAMP, HOSE 1-1/8" R/C W 3/8
13	170.006.090	15	HC-8.8 M6 X 1.00 X 90
14	1274231	4	HM PLT, HYDRO HOSE SUPPORT
15	1276391	2	HM CLAMP SPACER
16	191.006	1	HN-8.8M6X1.0 NYLOCK
17	1264501	1	LM ASM, HANDLE, ROCK TRAP
18	1290741	2	LM SHT, ROCK TRAP LINKAGE, UPPER
19	1276351	1	HOSE, 1-1/2" BELLOWSFLEX HARDWALL 14"
20	1063.24.24	1	UNION, -24MB x -24MB
21	152061	2	CLAMP, HOSE, WORM GEAR, 1.5" TO 2.5"

Model JS9010 Hillco Leveling System
For Serial Numbers JS9010-16001 thru JS9010-16999

Carriage Position Sensor				
BOM ID	Hillco Part No.	John Deere Part No.	Qty	Description
1	151341	H168732	2	BALL STUD (H168732)
2	123.006	-	2	FLHN-10.9M6X1.00
3	151331	AH226146	1	LINKAGE, POSITION (AH226146)
4	151371	AXE17303	1	ARM, ASSY, TILT SENSOR, HM (axe17303)
5	151361	R41076	1	BUSHING, (R41076)
6	141841	-	2	EM ASM, CLINOMETER (Only 1 used on Sidehill's)
7	115.#06.004	-	4	PHMS #6-32X1/4
8	1295142	-	1	EM SHT, SENSOR MNT, CLINOMETER
9	122.012.035	-	1	FLHC 10.9 M12 X 1.75 X 35 PLT
10	142121	-	1	STRAIN RELIEF NUT, 1/2" BLACK
11	138781	-	1	STRAIN RELIEF, NYLON, BLK,
12	123.012	-	1	FLHN-10.9 M12 x 1.75 PLT
13	170.008.010	19m7008	2	HC-8.8M8X1.25X10 (19m7008)
14	151321	HXE16001	1	BRACKET, SENSOR MNT (HXE16001)
15	151391	P48347	1	O-RING, 11/16ID (P48347)
16	151401	AXE14888	1	SHAFT, ROUGH SERVICE DEVICE (AXE14888)
17	201.006.036	-	1	PIN, ROLL 6mm x 36mm
18	151381	AXE14246	1	SENSOR, ROTATION, HALL 2CH +/-120DE (axe14246)
19	170.004.035	19M9368	2	HC-8.8M4X0.7X035 (19m9368)
20	1303151	-	1	EM SHT, SHIELD SENSOR

Model JS9010 Hillco Leveling System
For Serial Numbers JS9010-16001 thru JS9010-16999

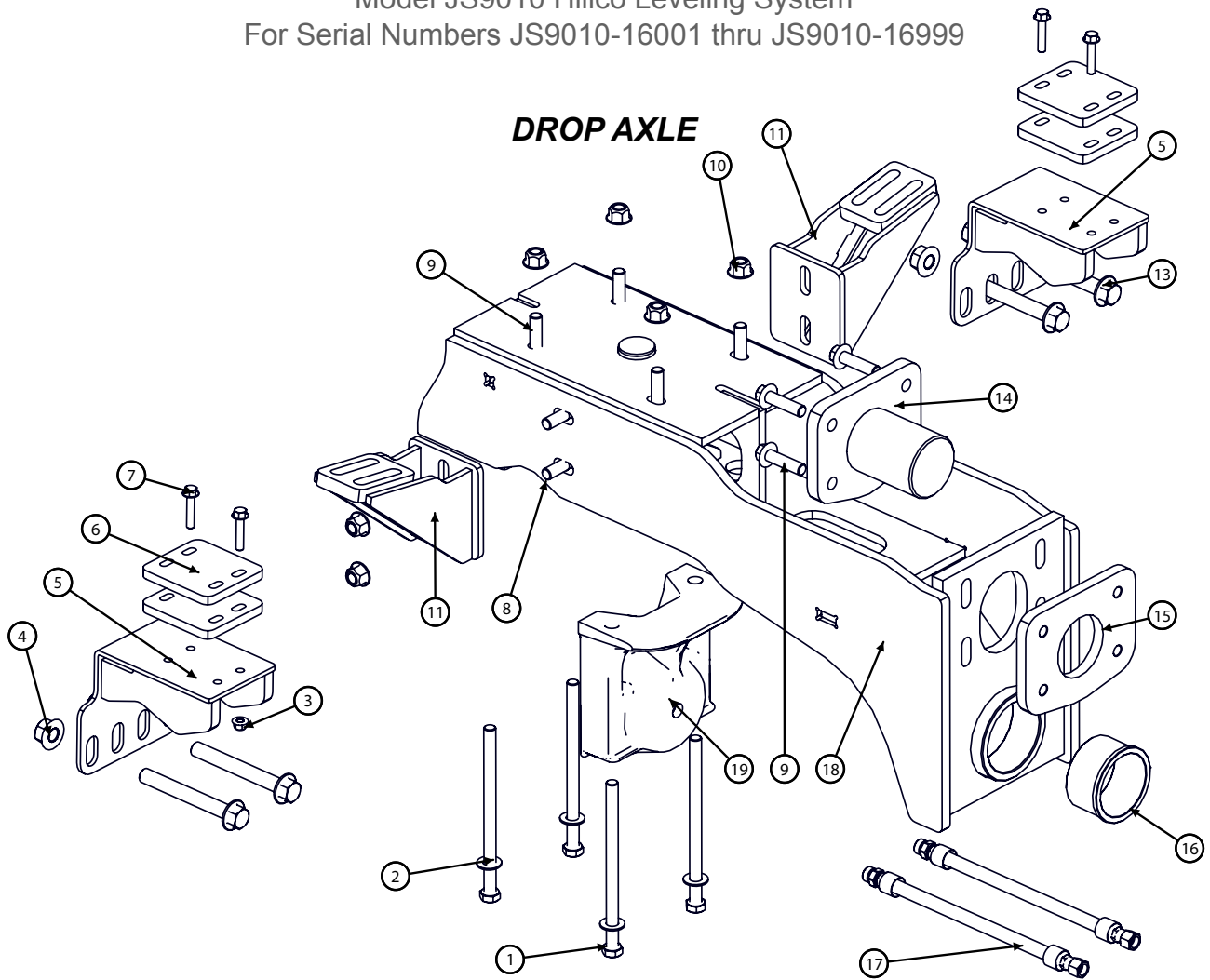

Drop Axle			
BOM ID	Part No.	Qty	Description
1	121.016.250	4	BOLT,HX,CL10.9 M16X250
2	133.01	4	WASHER,L9,HD 5/8
3	128.01	4	NUT,HX,FL,STV,CL10 M10
4	123.020	4	NUT,HX,FL,CL10 M20
5	1299792	2	ROTATION STOP
6	1299892	4	ROTATION STOP 16°
7	122.010.050	4	BOLT,HX,FL,CL10.9 M10X50
8	122.016.050	4	BOLT,HX, FL, CL10.9 M16X50
9	122.016.060	8	BOLT, HX, FL, CL10.9, M16X60
10	128.016	12	NUT,HX,FL,STV,CL10 M16
11	1313541	2	WING
13	122.020.160	4	BOLT,HX,FL,CL10.9 M20
14	1291071	1	PIVOT PIN
15	1291091	1	PIVOT LOCK
16	1235092	1	BUSHING, PIVOT
17	1273461	2	3/8" R2 #8FF#8MF 15"
18	1291023	1	DROP AXLE
19	1299801	1	STAND-OFF, REAR AXLE

Model JS9010 Hillco Leveling System
For Serial Numbers JS9010-16001 thru JS9010-16999

Hydraulic Components

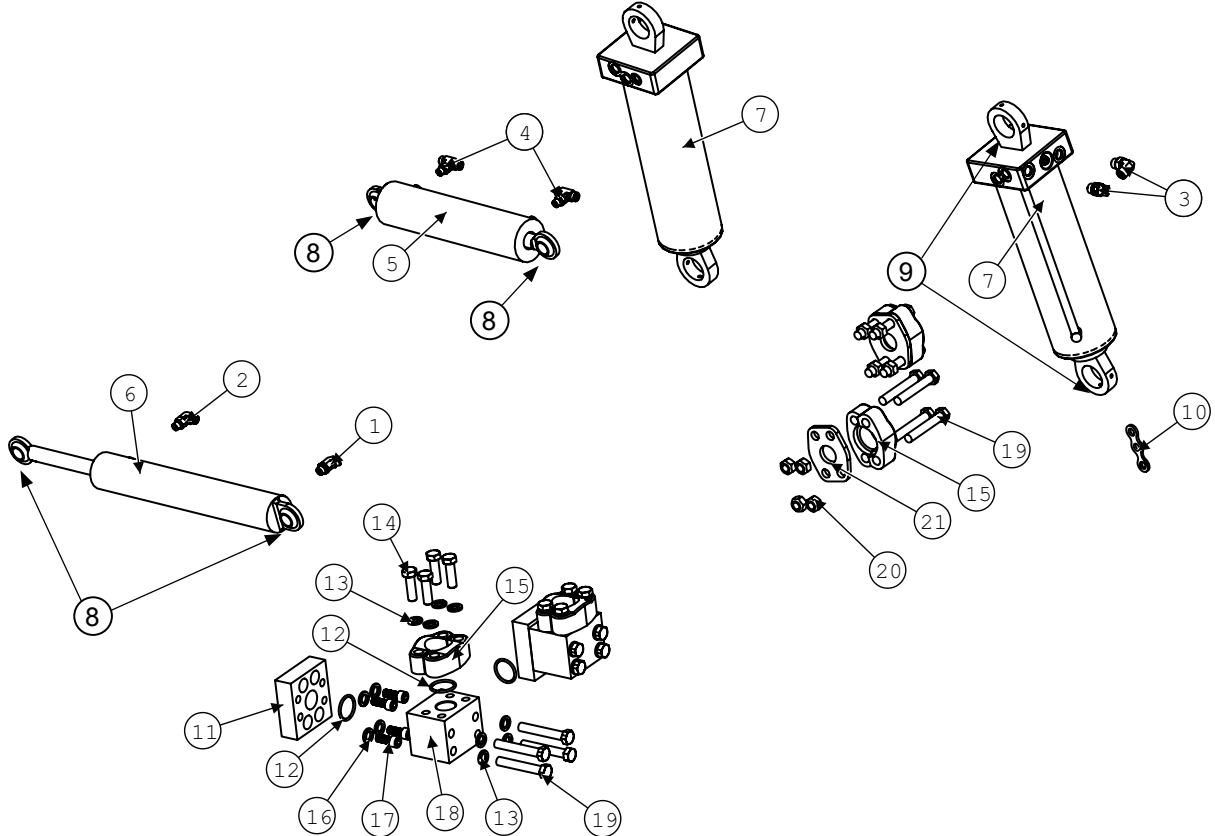

Hydraulic Components			
BOM ID	Part No.	Qty	Description
1	1001.06.06	2	#6 MORS X #6 MORB 45 DEG
2	1003.06.06	2	ELBOW, 90°, 6MF x 6MO
3	1003.08.08	3	ELBOW, 90°, #8MORS#8MORB
4	1009.06	5	TEE, STRAIGHT THREAD, BRANCH -6MF x -6MO
5	140342	2	MASTER CYLINDER, 3"B, 8-3/4"S,1-3/8"R, 17-1/4"CPC, CROSS
NS	HC-134201	-	SEAL KIT, MASTER CYLINDER
6	138582	4	SLAVE CYLINDER, 2-1/2 B, 1-1/8" R, 12-1/2" S, 21" CPC
NS	HC-141281	-	SEAL KIT, SLAVE CYLINDER
7	151002	2	LEVELING CYLINDER, 4-1/2"B,11"S,2"R, 22-1/2 CPC
NS	HC-135221	-	SEAL KIT, LEVELING CYLINDER
8	MC-140321	4	1" BEARING, SEALED SPHERICAL
9	MC-150881	4	1 3/8" BEARING, SEALED SPHERICAL
10	LP-274391	1	LM PLT, HYDRO HOSE SPACER
11	LM-272092	2	CODE 62 90° 1-1/4 ROTATIONAL ADAPTER
12	147621	8	O-RING, CODE 62, 1-1/4"
13	139.009	16	LW 9/16 HD
14	121.014.045	8	HC-10.9M14 X2.0X45
15	147611	8	FLANGE, 1-1/4" CODE 62, HALF
16	135.009	8	LW 9/16 HD HIGH COLLAR
17	159.014.030	8	SHCS-12.9M14X2.0X30
18	LM-272082	2	HM BLOCK, CODE 62 1-1/4 90°
19	121.014.090	16	HC-10.9 M14X2.0X90
20	126.014	8	HN-10.9M14X2.0 STVR
21	1272161	2	HM PLT, CODE 62 1-1/4 UNION

Leveling Manifold

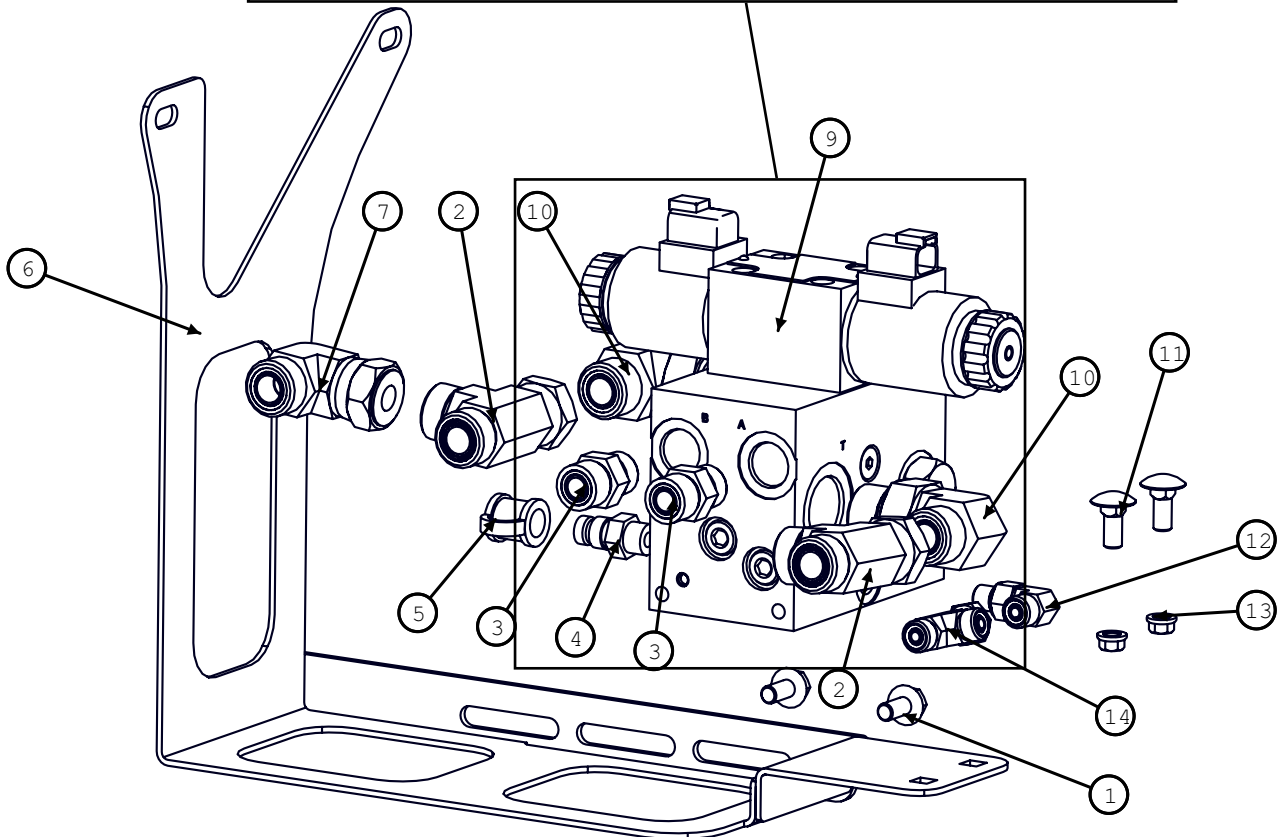
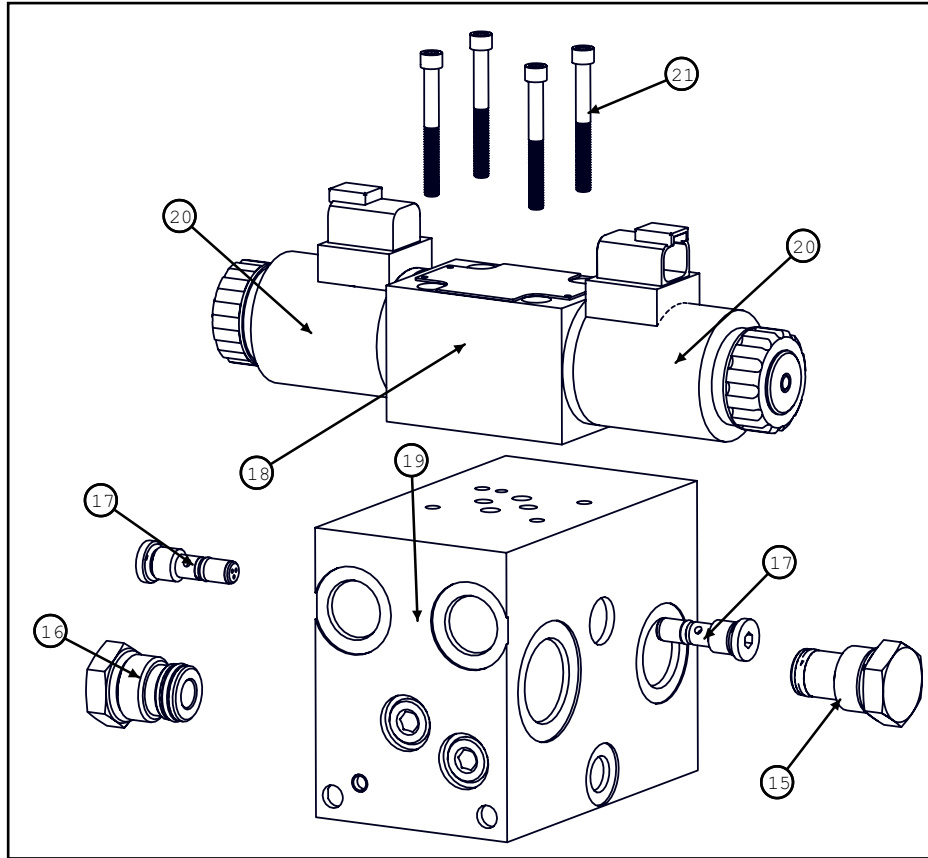

Model JS9010 Hillco Leveling System
For Serial Numbers JS9010-16001 thru JS9010-16999

Leveling Manifold			
BOM ID	Part No.	Qty	Description
1	111.005.010	2	BOLT,HX,FL,GR5 5/16-18X5/8
2	1008.1	2	HA,TEE,SWV,NUT,RUN
3	1001.08.08	2	HA,STR
4	143991	1	COUPLER,
5	144001	1	DUST COVER
6	1313601	1	MANIFOLD MOUNT
7	1006.10.10	1	HA,90°
9	1312741	1	MANIFOLD, CUSTOM, LEV
10	1003.12.10	2	HA,90°
11	163.008.020	2	BOLT,CARR,CL8.8 M8X20
12	1003.04.04	1	HA,90°
13	119.005	2	NUT,HX,FL,SERR 5/16-18
14	1008.04	1	SWV,NUT,RUN -4ORFS
15	155238	1	CAVITY PLUG, 2 WAY, 10 SERIES
16	155234	1	CAVITY PLUG, 3 WAY, 10 SERIES
17	155236	2	CHECK VALVE, REVERSE DIRECTION
18	155237	1	DIRECTIONAL VALVE,PROPORTIONAL (INCLUDES 155239)
19	155235	1	VALVE BODY, LEVELING
20	155239	2	SOLENOID COIL,D03,PROP,DEUTSCH
21	196.#10.028	4	SHCS 10-24 X 1.75

Header Trim Manifold

(Only on combines without factory Header Tilt. All stock corn combines come equipped with Contour Master.)

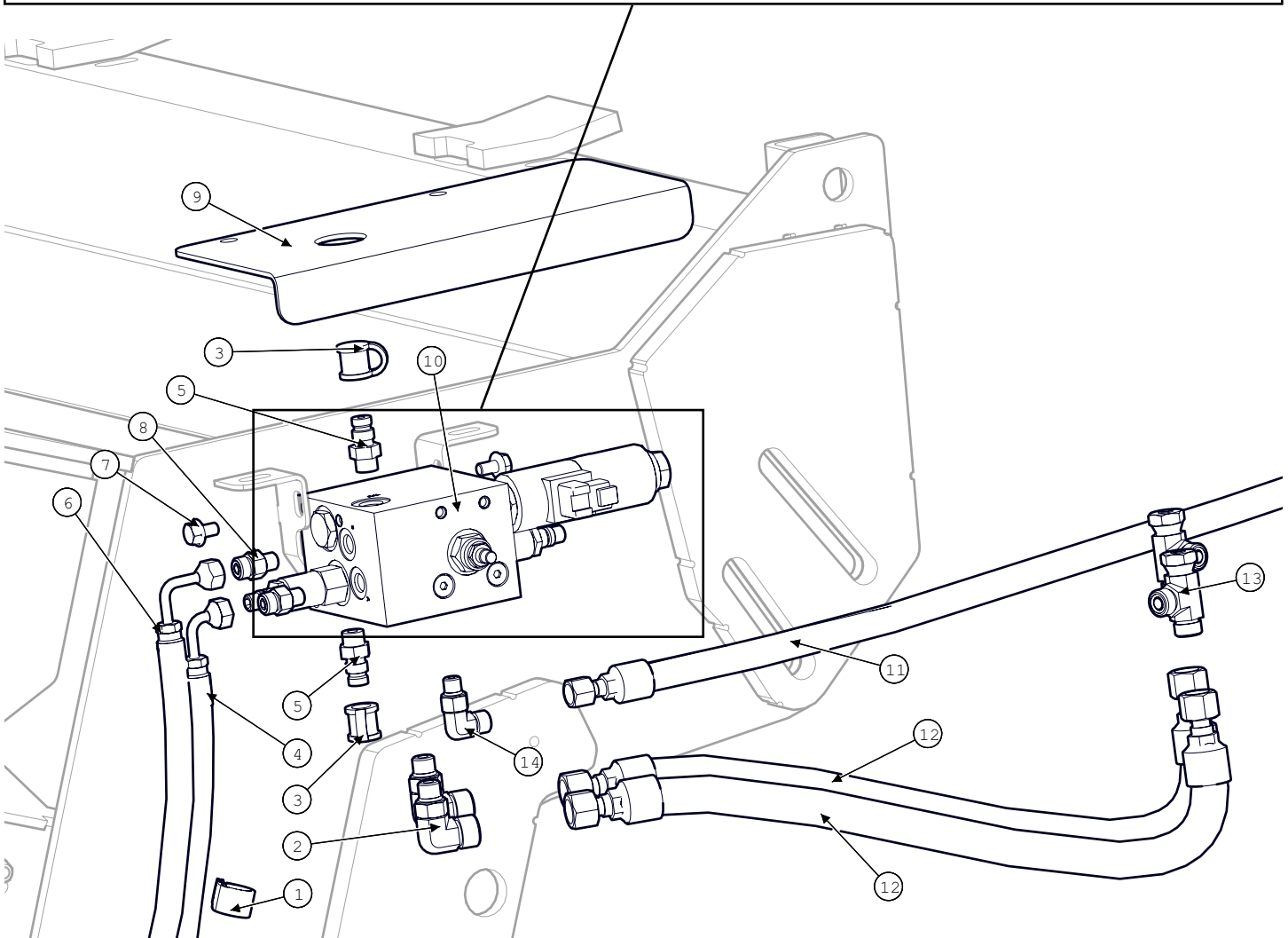
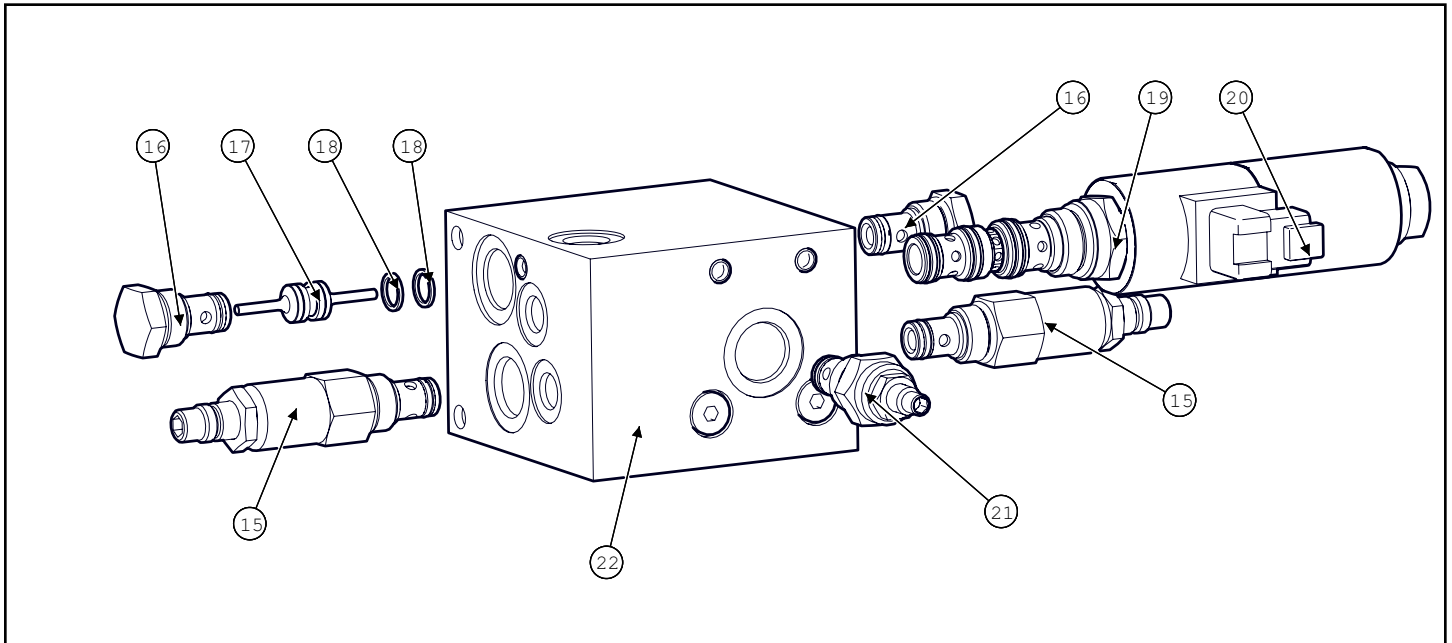

Model JS9010 Hillco Leveling System
For Serial Numbers JS9010-16001 thru JS9010-16999

Header Trim Manifold			
BOM ID	Part No.	Qty	Description
1	135791	2	CLAMP, HOSE
2	1003.08.06	2	-8MORB X -6MORFS
3	144001	2	DUST COVER
4	1322112	1	100R17-04 67",
5	143991	2	COUPLER,
6	1322101	1	100R17-04X80",
7	111.005.008	2	BOLT,HX,FL,GR5 5/16-18X1/2
8	1001.04.04	2	HA,STR
9	1316463	1	SHIELD, TRIM SHIELD
10	1326261	1	MANIFOLD, CUSTOM, TRIM
11	1320721	1	100R17AR-04X138",
12	1320711	2	100R17AR-06X38",
13	1008.06	2	SWIVEL NUT, RUN, -6ORFS
14	1003.04.04	1	HA,90°
15	155243	2	CARTRIDGE, PRESSURE RELIEF,
16	155246	2	CHECK VALVE, CARTRIDGE
17	155245	1	PILOT PISTON, DOUBLE ACTING
18	155247	2	BACKUP RING
19	155249	1	CARTRIDGE VALVE, 3 POS,4 WAY (INCLUDES 155248)
20	155248	2	SOLENOID COIL, CARTRIDGE, PROP
21	155244	1	NEEDLE VALVE, ADJUSTABLE FLOW
22	155242	1	VALVE BODY, TRIM

John Deere Header Lift Manifold Fittings

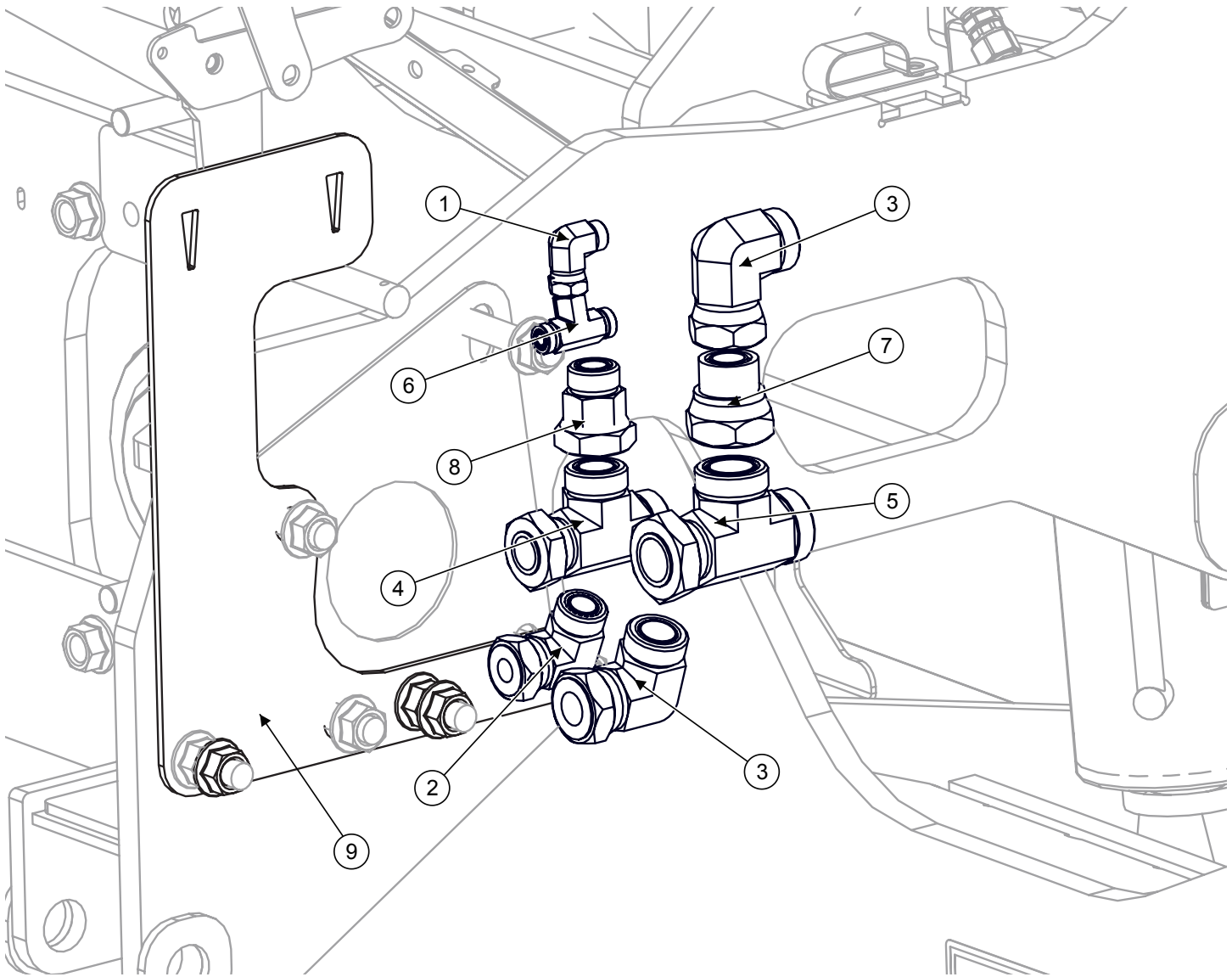

John Deere Header Lift Manifold Fittings			
BOM ID	Part No.	Qty	Description
1	1006.06.06	1	ELBOW, 90°, -6FF x -6MF
2	1006.12.12	1	ELBOW, 90°, -12MF x -12FF
3	1006.16.16	2	ELBOW, 90°, -16MF x -16FF
4	1008.16	1	TEE, SWIVEL NUT, RUN, #16
5	1008.20	1	TEE, SWIVEL NUT, RUN, #20
6	1008.06	1	TEE, SWIVEL NUT, RUN, -6FF x -6MF
7	1004.20.16	1	STR, -20FF x -16MF
8	1004.16.12	1	STR, 16FF x 12MF
9	1297821	1	MANIFOLD SPACER

Model JS9010 Hillco Leveling System
For Serial Numbers JS9010-16001 thru JS9010-16999

Hydraulic Hoses

Hydraulic Hoses			
Part No	Qty	Description	Hose Specs
1138942	1	Grease Hose	HOSE, 100R1-03, 33-1/2" 1/8 MPT X 1/8 MPT
1138951	1	Grease Hose	HOSE, 100R1-03, 40" 1/8 MPT X 1/8 MPT
1138963	1	Grease Hose	HOSE, 100R1-03, 54" 1/8 MPT X 1/8 MPT
1138974	2	Grease Hose	HOSE, 100R1-03, 77" 1/8 MPT X 1/8 MPT
1152451	1	Connect Yellow Port to Slave Cyl Base Port	HOSE ASM, 100R2-04 80", -6FF STR x -6FF 90°
1152461	1	Connects C/M Blue Port to Rod Port	HOSE ASM, 100R2-04 70", -6FF STR x -6FF 90°
1273461	2	Extends Steer Hoses	HOSE, 3/8" R2 #8FF#8MF 15"
1273462	2	Filter head; Front & Side Port to Valve Block Ports	HOSE ASM, 100R2-08 62", #10FF x #8FF 90°
1274141	1		HOSE ASM, 100R15-20 124", 90° XR FLNG x STR FLNG
1293431	2	Extends Rear Hydrostat Line	HOSE, 100R2-06 47" #8FORS #8FORS 90°
1295601	2	Leveling Manifold to Leveling Cyl	HOSE, 100R2-08, 103" 08FORSx08FORS
1295882	2	Connects Master Cyl to Slave Cyl	HOSE, 100R2-06 X 195" .-06FF STR x -06FF STR
1297421	1	Extends AH226084 to Proportionator Motor Supply	HOSE ASM, 100R2-10 66", -10FF 90° x -10MF STR
1297441	1	Extends AH226085 to Proportionator Pump Supply	HOSE ASM, 100R1-12 66", -12FF 90° x -12MF STR
1297452	1	Replaces AH219243; Connects Rear Filter Port to Proportionator Motor Return	HOSE ASM, 100R2-10 147", -10FF STR x -10FF 90°
1297481	1	Extends AH226119 to the Trans Lube	HOSE ASM, 100R2-06 31", -6FF 90° x -6MF STR
1297641	1	Extends Right Brake Hose	HOSE ASM, 100R2-06 78", -06MF STR x -06FF 90°
1297651	1	Extends Left Brake Line; Extends Lube Line	HOSE ASM, 100R2-06 60", -06MF STR x -06FF STR
1297841	1	Return, Manifold to Tee	HOSE ASM, 100R1-12 68", -16 90° x -10 STR
1297851	1	Pressure, Manifold to Tee	HOSE ASM, 100R2-10 72", -12 90° X -10 STR
1297863	1	Load Sense, Manifold to Tee	HOSE ASM, 100R2-04 80", -6 STR x -4 90°
1297922	1	Replaces JD Hose; Connects Manifold to Tee	HOSE ASM, 100R16-12 91", -12FF 90° x -12FF STR
1297932	1	Replaces Left Header Lift Pressure Hose	HOSE ASM, 100R16-12 44", -12FF STR x -12FF STR
1298291	1	Extends ProDrive Case Drain	HOSE ASM, 100R1-16 36", -16MF x -16FF
1298321	1	Replaces Right Header Lift Pressure Hose	HOSE ASM, 100R16-12 42", -12FF STR x -12FF 90°
1298331	1	Replaces the Header Lift Pressure Hose	HOSE ASM, 100R17-16 90", -16FF STR x -16FF 90°
1299191	1	Extends JH Hose to Shift Block	HOSE ASM, 100R2-04 15", -6FF 90° X -6MF STR
1305181	1	Replaces Forward Hydro Hose	HOSE ASM, 100R15-20 121", 90° MR FLNG x STR FLNG
1313641	1	CONNECTS TRIM MANIFOLD LOAD SENSE TO TEE AT LEVELING MANIFOLD	HH ASM, 451TC-04, 42", -4FF STR X -4FF 90°
1313651	1	CONNECTS TRIM MANIFOLD T PORT TO TEE AT LEVELING MANIFOLD	HH ASM, 451TC-06, 45", -10FF STR X -6FF STR
1313661	1	CONNECTS TRIM MANIFOLD P PORT TO TEE AT LEVELING MANIFOLD	HH ASM, 451TC-06, 36", -10FF STR X -6FF STR
1313671	1	CONNECTS TRIM MANIFOLD A PORT TO ROD PORT OF MASTER CYLINDER	HH ASM, 451TC-04, 137", -4FF 45° X -6FF STR
1313681	1	CONNECTS TRIM MANIFOLD B PORT TO BASE PORT OF	HH ASM, 451TC-04, 126", -4FF 45° X -6FF STR

Model JS9010 Hillco Leveling System
For Serial Numbers JS9010-16001 thru JS9010-16999

SINGLE STEP RETRACTABLE LADDER

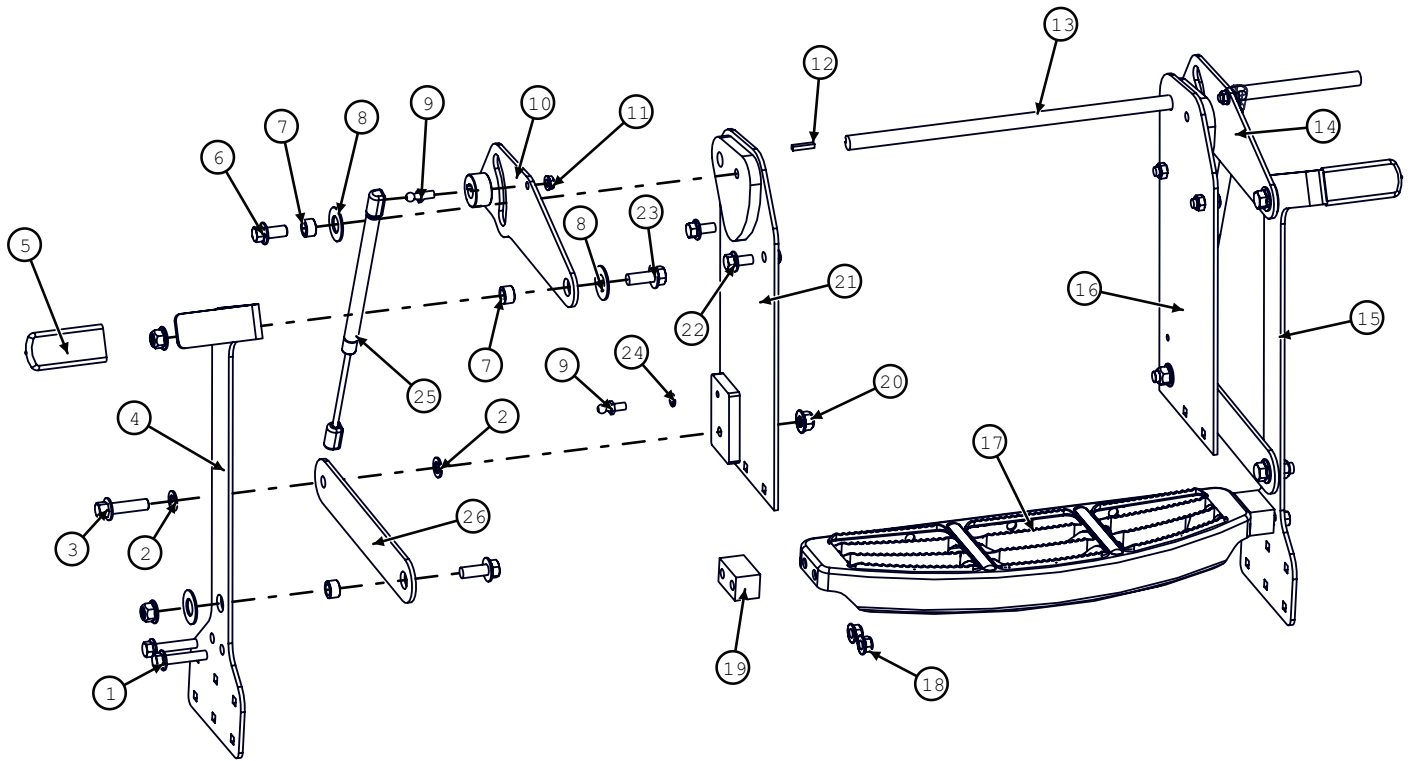

Model JS9010 Hillco Leveling System
For Serial Numbers JS9010-16001 thru JS9010-16999

Retractable Ladder

BOM ID	Part No.	Qty	Description
ASM	LA-297171	1	LM ASM, MOVING STEP (SIDEHILL)
1	F-HCF-10M050E	4	SCREW, FLANGED HEX CAP
2	F-MB-14NR08	4	MACHINE BUSHING 14GA NR 1/2ID
3	F-HCF-12M045E	2	FLHC-10.9M12X1.75X45
4	LB-298222	1	LM PLT, LADDER HANDLE, RIGHT
5	MC-151921	2	GRIP, JD#W25634
6	F-HCF-12M025E	2	FLHC-10.9M12X1.75X25
7	LM-299181	6	LM BUSHING, LADDER PIVOT
8	153.014.012	6	BUSHING, MACH, WR
9	MC-134931	2	LIFT SUPPORT BRACKETS (PAIR)
10	LW-298272	1	LM ASM, UPPER CONTROL LINK, RIGHT
11	F-HNF-05C	2	FLHN 5/16-18
12	F-KST-03X03X16	2	KEY, STR, 3/16 X 3/16 X 1
13	LM-298191	1	LM RND, ROCK SHAFT
14	LW-298252	1	LM WLD, UPPER CONTROL LINK
15	LB-298182	1	LM PLT, LADDER HANDLE, LEFT
16	LM-298132	1	LM WLD, LFT LADDER MNT
17	MC-152601	1	STEP, PLATFORM, STEP (HXE19816)
18	F-HNFS-10ME	8	FLHN-10.9M10X1.5 STVR
19	LM-299071	2	LM SPACER, LADDER STEP
20	F-HNFS-12ME	6	FLHN-10.9M12X1.75 STVR
21	LM-298212	1	LM WLD, RHT LADDER MNT
22	F-HCF-10M020E	4	FLHC-10.9 M10X1.75X20
23	F-HCF-12M30E	4	FLHC-10.9 M12X1.75X30
24	F-LW-05	2	LOCK WASHER 5/16"
25	MC-139251	2	GAS CHARGED LIFT SUPPORT
26	LM-298171	2	LM PLT, LOWER CONTROL LINK

Model JS9010 Hillco Leveling System
For Serial Numbers JS9010-16001 thru JS9010-16999

DOUBLE STEP RETRACTABLE LADDER

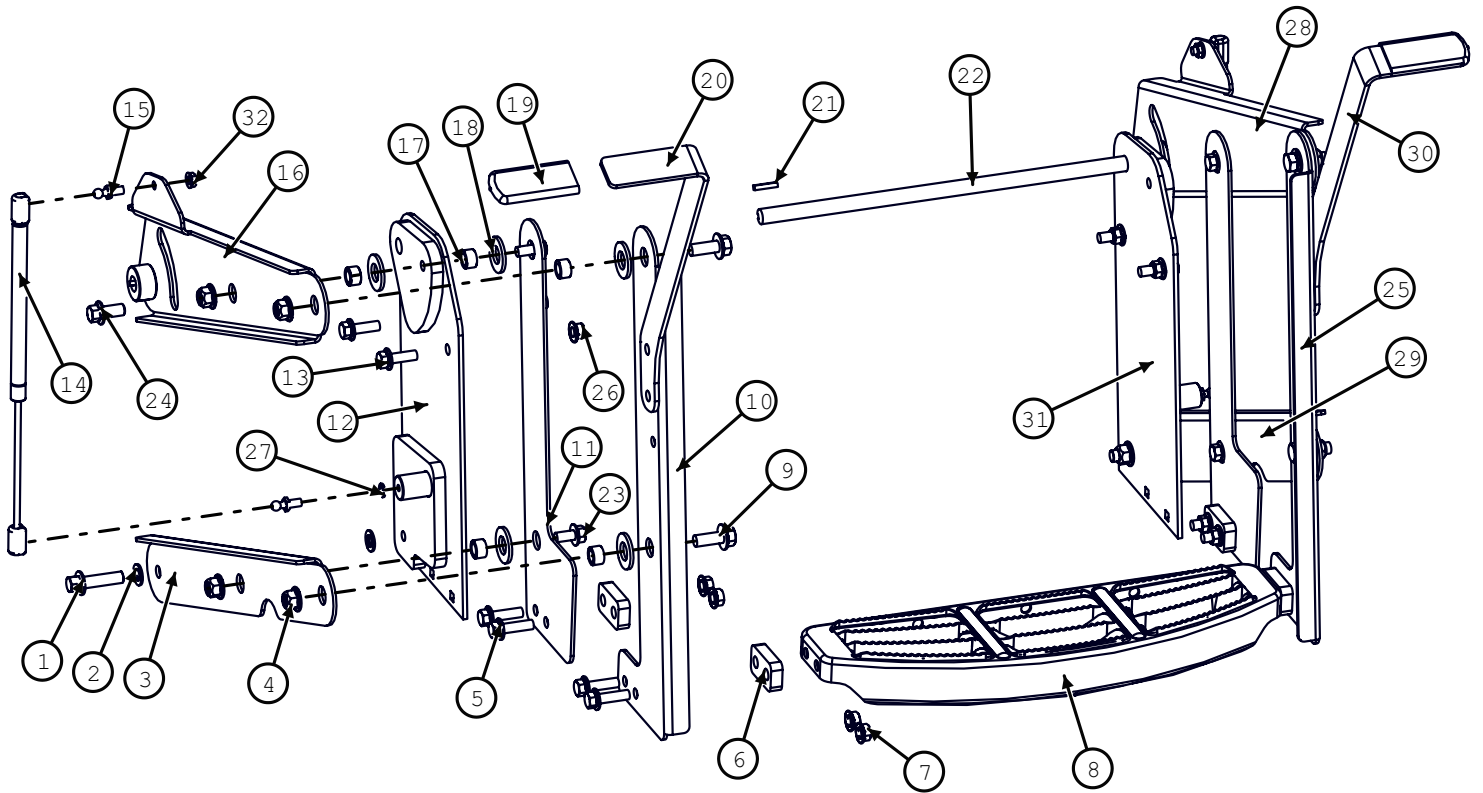

Model JS9010 Hillco Leveling System
For Serial Numbers JS9010-16001 thru JS9010-16999

Retractable Ladder

BOM ID	Part No.	Qty	Description
1-32	1300211	1	ASSEMBLY, MOVING STEP (HILLSIDE)
2	122.012.045	2	FLHC-10.9M12X1.75X45
2	162.014.008	4	MACHINE BUSHING 14GA NR 1/2ID
3	1300091	1	LM LINK, LWR RIGHT PARALLEL
4	128.012	10	FLHN-10.9M12X1.75 STVR
5	122.010.035	8	SCREW, FLANGED HEX CAP, 10.9
6	1300191	4	LM SPACER, STEP
7	123.01	12	FLHN-10.9 M10 X 1.50
8	152601	1	STEP, PLATFORM, STEP (HXE19816)
9	122.012.030	4	FLHC-10.9 M12X1.75X30
10	1300162	1	LM PLT, VERTICAL OUTER RIGHT
11	1300111	2	LM LINK, VERTICAL INNER
12	1300061	1	LM WLD, RHT LADDER MNT
13	122.010.030	4	FLHC 10.9 M10 X 1.5 X 30
14	155327	2	STRUT, LIFT, 100LB, 15OPC, 6" STROKE
15	134931	4	LIFT SUPPORT BRACKETS (PAIR)
16	1300121	1	LM WLD, TOP RIGHT LINK
17	1299181	10	LM BUSHING, LADDER PIVOT
18	153.010.012	10	MACHINE BUSHING 10GA WR 3/4ID
19	151921	2	GRIP, JD#W25634
20	1306351	1	LM PLT, HANDLE, LEFT
NS	1316512	1	LM PLT, HANDLE, LEFT - SHORT
21	10049.03.00016	2	KEY, STR, 3/16 X 3/16 X 1
22	1298191	1	LM RND, ROCK SHAFT
23	122.010.020	4	FLHC-10.9M10X1.75X20
24	122.012.025	2	FLHC-10.9M12X1.75X25
25	1300172	1	LM PLT, VERTICAL OUTER LEFT
26	128.01	4	FLHN-10.9M10X1.5 STVR
27	136.005	2	LOCK WASHER 5/16"
28	1300141	1	LM WLD, TOP LEFT LINK
29	1300101	1	LM LINK, LWR LEFT PARALLEL
30	1300182	1	LM PLT, LADDER HANDLE RIGHT
NS	1316502	1	LM PLT, HANDLE, RIGHT - SHORT
31	1300051	1	LM WLD, LEFT LADDER MNT
32	119.005	2	FLHN 5/16-18

Ladder Wedge

For Wide Under Carriage Combines or Narrow Under Carriage Combines with Axle Extensions

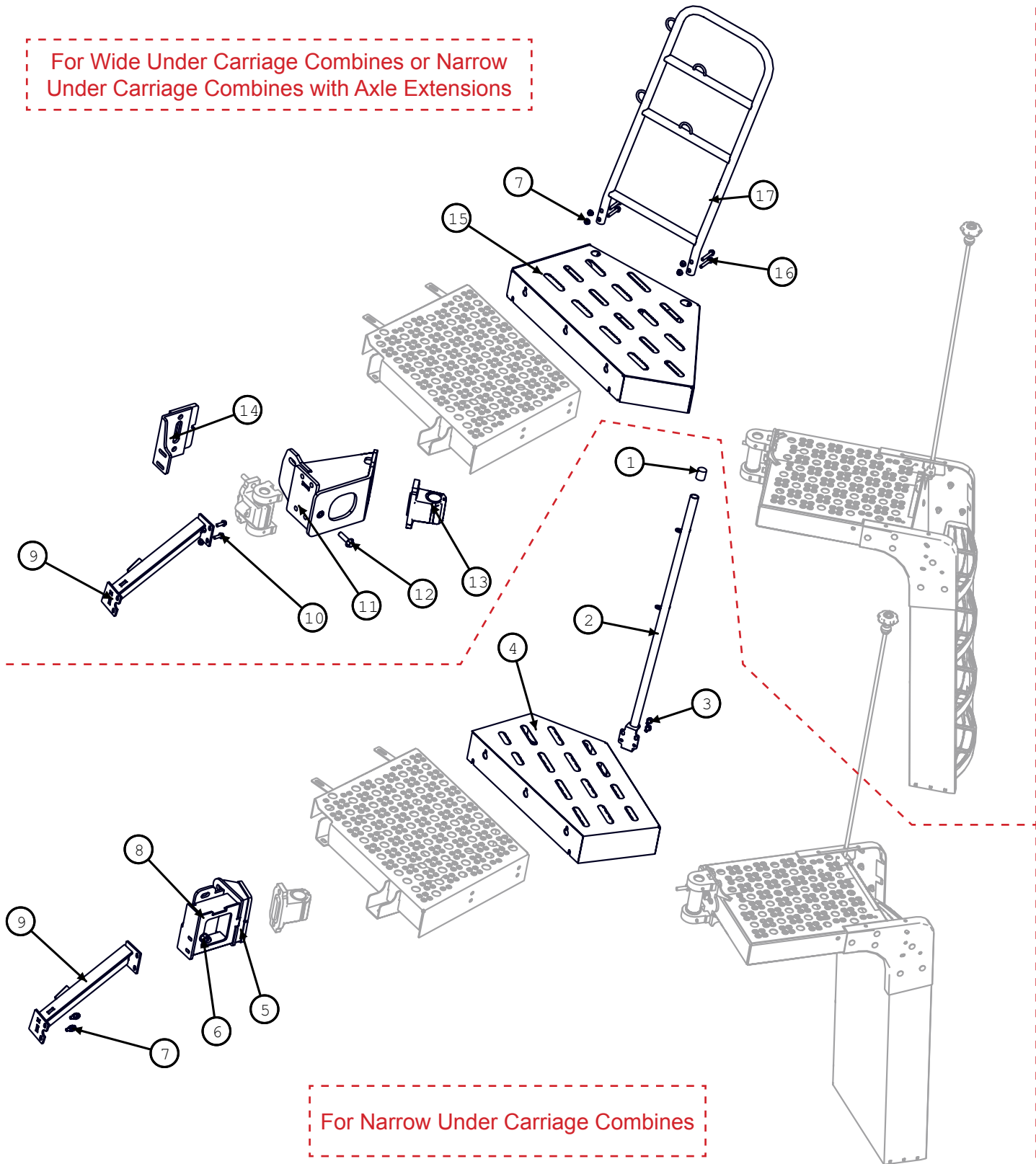

For Narrow Under Carriage Combines

Model JS9010 Hillco Leveling System
For Serial Numbers JS9010-16001 thru JS9010-16999

Ladder Wedge			
BOM ID	Part No.	Qty	Description
1-9	1314181	1	Narrow Undercarriage Ladder
1	151681	1	SHORT CAP, BLK, 1-1/4ID X 1-1/2L
2	1296681	1	HANDRAIL CORNER
3	122.010.020	4	BOLT,HX,FL,CL10.9 M10X20
4	1301803	1	PLATFORM, 17"
5	122.016.050	2	BOLT,HX,FL,CL10.9 M16X50
6	123.016	1	NUT,HX,FL,CL10 M16
7	123.01	12	NUT,HX,FL,CL10 M10
8	1300681	1	PIVOT EXTENSION
9-17	1314171	1	Wide Undercarriage Ladder or Narrow with Axle Extensions
9	1296081	2	LADDER BRACE
10	122.010.030	4	BOLT,HX,FL,CL10.9 M10X30
11	1300932	1	PIVOT EXTENSION
12	122.016.060	1	BOLT,HX,FL,CL10.9 M16X60
13	154501	1	PIVOT, LADDER,
14	1301181	1	SUPPORT BRACKET
15	1301102	1	PLATFORM
16	122.010.060	4	BOLT,HX,FL,CL10.9 M10X60
17	MC-153571	1	HANDRAIL, EXTENSION ASSY FRONT (AXE16380)

Controller/Wiring Harnesses

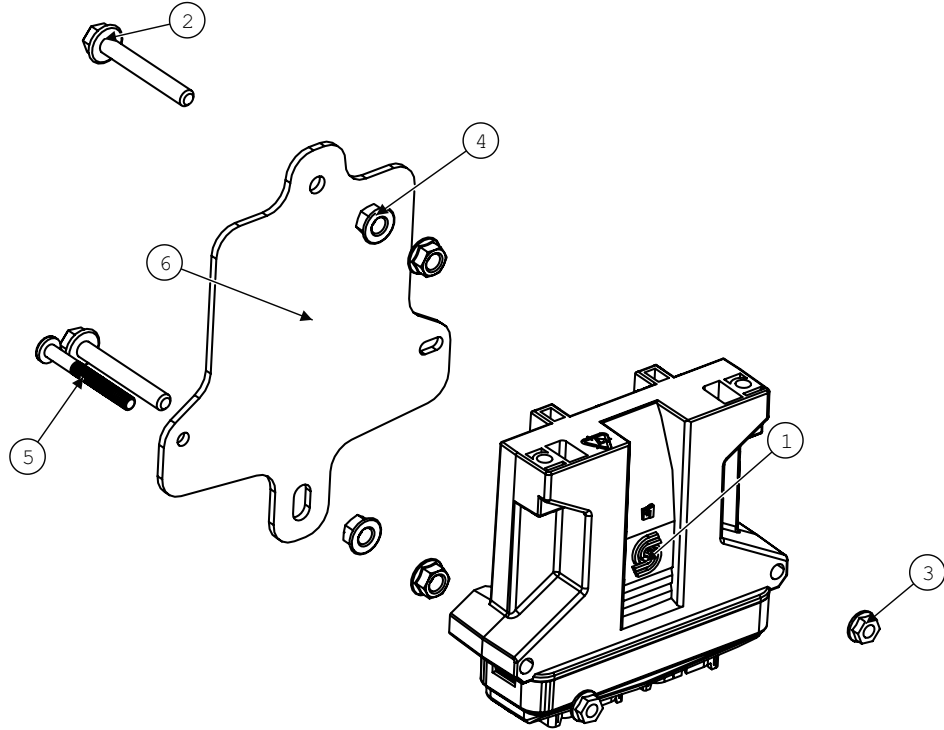

Electrical Components			
BOM ID	Part No.	Qty	Description
1-6	LA-295211	1	EM ASM, CONTROLLER W/MNT
1	1295221	1	SAUER-DANFOSS PLUS 1 CONTROLLER
2	122.008.060	2	FLHC-M08X1.25X60
3	119.004	2	FLHN-GR5 1/4-20
4	123.008	4	FLHN 10.9 M8 X 1.25
5	114.004.036	2	PHMS-GR5-1/4-20 X 2-1/4"
6	1295201	1	EM PLT, CONTROLLER MNT

Wiring Harnesses			
BOM ID	Part No.	Description	Purpose
NS	1294743	EM HARNESS, PRIMARY	POWER SUPPLY & SENSOR PACKAGE
NS	1295342	EM HARNESS, TA SENSOR	TRANSITION TILT SENSOR
NS	1295181	EM HARNESS, SENSOR PACKAGE	SENSOR PACKAGE WIRING
NS	1322771	TRIM SIGNAL EXTENSION	CONNECTS TRIM MANIFOLD TO DEERE CONTOUR MASTER
NS	1320731	HEADER TRIM	CONNECTS TRIM MANIFOLD TO DEERE CONTOUR MASTER
NS	1319741	PRIMARY HARNESS EXTENSION	EXTENSION FOR POWER SUPPLY
NS	1323231	CAB POWER PIGTAIL	POWER SUPPLY

Model JS9010 Hillco Leveling System
For Serial Numbers JS9010-16001 thru JS9010-16999

Decals and Literature



1) LL-133741



2) LL-151031

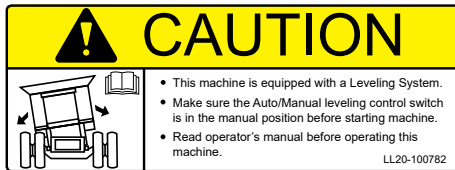

3) LL20-100782



4) LL20-100784



5) LL20-100783

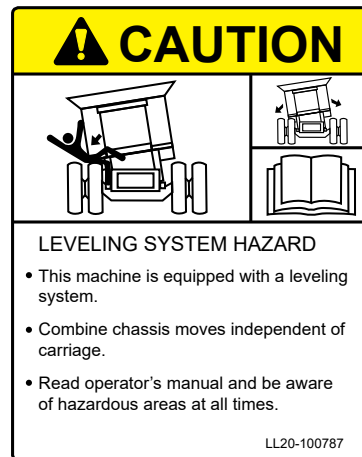

6) LL20-100787



7) LL20-100786



8) LL20-100788



9) LL-143621

Model JS9010 Hillco Leveling System
For Serial Numbers JS9010-16001 thru JS9010-16999

DECALS AND LITERATURE				
REF.	PART NO.	QTY.	PART NAME	DESCRIPTION
1	LL-133741	1	LABEL, GREASE 50 HRS	OC BULKHEAD
1	LL-133741	2	LABEL, GREASE 50 HRS	RIGHT & LEFT MAIN LEV CYL BOTTOM
1	LL-133741	1	LABEL, GREASE 50 HRS	MASTER CYLINDER ROD
2	LL-151031	2	DECAL, HILLSIDE LEVELING SYSTEM	SIDE OF COMBINE
4	LL20-100782	1	CAUTION LEVELING SYSTEM CAB	WINDOW IN CAB
5	LL20-100783	2	DANGER, CRUSHING HAZARD	RIGHT & LEFT UNDERCARRIAGE
5	LL20-100783	2	DANGER, CRUSHING HAZARD	SIDES OF DROP AXLE ASSEMBLY
6	LL20-100784	2	DECAL, DANGER PINCH POINT	RIGHT & LEFT UPPER TRANS FACE PLT
7	LL20-100786	1	WARNING ELECTRICAL CRUSHING HAZARD	FRONT OF ELECTRICAL CONTROL BOX
8	LL20-100787	1	CAUTION - LEVELING SYSTEM HAZARD	ON LADDER PLATFORM
9	LL20-100788	1	DANGER - HYDRAULIC HAZARD	ON SIDE OF COMBINE ABOVE THE HYDRAULIC MANIFOLD
9	LL20-100788	2	DANGER - HYDRAULIC HAZARD	FOR EACH LEVELING CYLINDER
10	LL-143621	2	DANGER, AVOID CRUSHING INJURY	IN AREA NEAR SAFETY STOP STORAGE LOCATION
NS	LL-147651	1	LABEL, FEMA MEMBER TAG	NEAR SERIAL NUMBER TAG
NS	LA-255961	1	TAG, SERIAL NUMBER	
NS	LL-289641	1	CM LABEL, MECHANICAL CYLINDER STOP	
NS	D-120620CMA01A	1	MANUAL, PARTS	
NS	D-111124CMA01B	1	MANUAL, OPERATORS	
NS	D-050611SLR01	1	WARRANTY REGISTRATION CARD	
NS	LL-239412	1	LABEL, STEERING WHEEL	TIED TO STEERING WHEEL DURING INSTALLATION
NS	D-120412CMA01	3	DEALER PDI & INSTALL CHECKLIST	

Model JS9010 Hillco Leveling System
For Serial Numbers JS9010-16001 thru JS9010-16999

Notes

Model JS9010 Hillco Leveling System
For Serial Numbers JS9010-16001 thru JS9010-16999

Hillco Technologies, Inc.
107 1st Avenue
Nezperce, Idaho 83543

Phone	800-937-2461
	208-937-2461
Fax	208-937-2280

www.hillcotechnologies.com
email: support@hillcotechnologies.com