



**LT-100**  
Lateral Header Tilt System  
**Operation & Parts Manual**

( D-030528CLA01B)



# **LT-100**

## **LATERAL HEADER TILT SYSTEM**

### **PARTS MANUAL**

FOR JOHN DEERE 9400, 9410, 9450, 9500, 9510, 9550, 9600, 9610, 9650, CTS, CTS II, 9650 CTS, 9650 STS & 9750STS

### **\*OPERATORS MANUAL**

\*ALL JOHN DEERE 50 SERIES COMBINES AND 1995 AND NEWER 9000 AND 10 SERIES COMBINES REFER TO YOUR JD COMBINE OPERATORS MANUAL UNDER CONTOUR MASTER™ FOR OPERATION INSTRUCTIONS BECAUSE THE OPERATION OF THE LT-100 IS IDENTICAL TO THE CONTOUR MASTER™. ALL 9000 SERIES COMBINES 1994 AND OLDER REFER TO THIS MANUAL.



D-030528CLA01 REV2

# INTRODUCTION

PLEASE READ THIS MANUAL COMPLETELY. This manual describes how to properly operate and service the LT-100. Failure to do so could result in personal injury or equipment damage.

This manual should be considered a permanent part of your combine and should remain with the combine as long as the LT-100 is attached to your John Deere combine.

The terms “Left, Right, Top, Bottom or Back” used in this manual are referenced as if sitting in the operator’s seat of the combine facing the direction of forward travel.

Record the serial number of the Hillco LT-100 here for future reference. The serial number is located on the left side of the LT-100.

Hillco LT-100 SN- \_\_\_\_\_



## **Statement of Limited Warranty**

Hillco Technologies, Inc. (Hillco) warrants its new products to be free from defects in material and workmanship for a period of twelve (12) consecutive months following the date of purchase by the retail purchaser.

Hillco warrants genuine Hillco replacement parts and components to be free from defects in material and workmanship for a period of six (6) consecutive months following the date of purchase or the remainder of the original equipment warranty period, whichever is longer.

Hillco's obligation under these warranties shall be limited to repairing or replacing, free of charge to the original purchaser, any part that, in Hillco's judgment, shows evidence of such defect.

### **Limitations to Warranty**

This warranty does not cover:

- 1) Warranty claims directly resulting from improper installation of the product.
- 2) Any product damaged by accident, abuse, misuse, or negligence after shipment from Hillco.
- 3) Any unauthorized product alteration or modification.
- 4) Any unauthorized repairs made with parts other than genuine Hillco parts.
- 5) Any repairs performed by anyone other than Hillco or an authorized Hillco dealer unless specifically authorized by Hillco.

### **Warranty Procedure**

A Hillco Warranty Registration Form must be fully completed and returned to Hillco within 30 days of sale of the product to the retail customer.

All warranty claims must be submitted on a Hillco Warranty Claim Form that is fully completed.

All warranty work must be performed, and claims submitted, within thirty (30) days of the occurrence of the claim and within the warranty period.

All parts removed during warranty repair should be held for a period of 60 days after the warranty claim has been submitted to Hillco.

Hillco reserves the right to either inspect the product at the original retail purchaser's location, or the authorized Hillco dealer's location; or require it to be returned to Hillco, F.O.B. Hillco, for inspection.

### **Limitation of Liability**

Hillco makes no express warranties other than those, which are specifically described herein. Any description of the goods sold hereunder, including any reference to buyer's specifications and any descriptions in circulars and other written material published by Hillco is for the sole purpose of identifying such goods and shall not create an express warranty that the goods shall conform to such description.

THIS WARRANTY IS EXPRESSLY IN LIEU OF ALL OTHER WARRANTIES EXPRESSED OR IMPLIED. There are no implied warranties of merchantability or fitness for a particular purpose. This warranty states Hillco's entire and exclusive liability and buyer's exclusive remedy for any claim for damages in connection with the sale or furnishing of Hillco products, their design, suitability for use, installation or operation, or for any claimed defects herein. HILLCO WILL IN NO EVENT BE LIABLE FOR ANY INCIDENTAL OR CONSEQUENTIAL DAMAGES WHATSOEVER, NOR FOR ANY SUM IN EXCESS OF THE PRICE RECEIVED FOR THE GOODS FOR WHICH LIABILITY IS CLAIMED.

No representative of Hillco nor any dealer associated with Hillco has the authority to change the items of this warranty in any manner whatsoever, and no assistance to purchaser by Hillco in the repair or operation of any Hillco product shall constitute a waiver of the conditions of this warranty, nor shall such assistance extend or revive it.

Hillco reserves the right to make improvements in design or changes in specifications at any time, without incurring any obligation to owners of units previously sold.

# SAFETY

## Safety Alert Symbol

When you see this symbol be alert to potential for personal injury or death. Follow recommended precautions and safe operating practices.



## Signal Words

These words are used with the safety alert symbol.

**DANGER** - An immediate and specific hazard that **WILL** result in severe personal injury or death.

**WARNING** - A specific hazard or unsafe practice that **COULD** result in severe personal injury or death if proper precautions are not taken.

**CAUTION** - Unsafe practices which **COULD** result in personal injury if proper practices are not taken, or as a reminder of good safety practices.



## HIGH PRESSURE FLUIDS

Escaping fluids under pressure can penetrate the skin causing serious injury.

Search for leaks with a piece of cardboard.

Relieve pressure before disconnecting hydraulic or other lines.

If an accident occurs consult a physician immediately.

Fluid injection into the skin must be surgically removed within a few hours or gangrene may result.

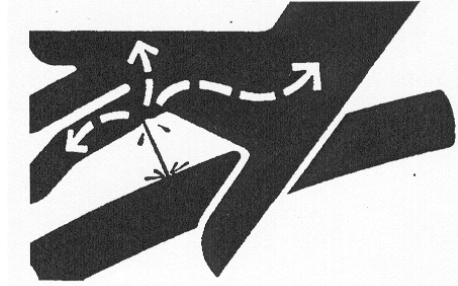

**SAFETY LABELS** are located on both the left and right side of the LT-100 as shown below.



# OPERATION

## OPERATING THE HILCO LT-100

**For John Deere 9400 SN (up to-660100), 9500 SN (up to-660200), 9600 SN (up to-660300), CTS SN (up to-660400) refer to this Hillco LT-100 Operators & Parts Manual.**

For John Deere 9450, 9550, 9650, 9650 CTS, 9650 STS & 9750 STS combines refer to the John Deere operator's manual for your model of combine under the Contour Master™ section for operation instructions.

For John Deere 9400 SN (660101- and up), 9500 SN (660201-and up), 9600 SN (660301-and up), CTS SN (660401-and up), 9410, 9510, 9610 & CTS II combines refer to the John Deere manual for your model of combine under the Contour Master™ section for operation instructions.

## HILCO LT-100 DESCRIPTION

The Hillco LT-100 is a bolt on aftermarket Lateral Header Tilt System designed to allow the operator to hydraulically tilt the header 4° manually or automatically in both directions.



The LT-100 uses the John Deere electronic circuit board to allow the John Deere Dial-A-Matic™ and Contour Master™ electronics and the Hillco LT-100 to work together to maintain the closest cutter bar position to the ground with flex platforms. If the Hillco LT-100 is switched to manual mode the John Deere Dial-A-Matic™ will still operate in automatic.

**NOTE:** On flex headers, the lateral tilt will be inactive if the head is off the ground or locked out.

## LT-100 CALIBRATION

To account for initial differences in the signals between the right and left sensor, it is necessary to level the system. This will need to be performed every time a different header is mounted onto the combine.



1. Turn the automatic switch to the manual position (A).

2. Engage the header.

3. (Rigid Platforms and Corn Heads) Raise the header until it clears the ground manually. Tilt the header by using the lateral header tilt switch (B) on the hydro handle until both ends of the header are equal distance from the ground.

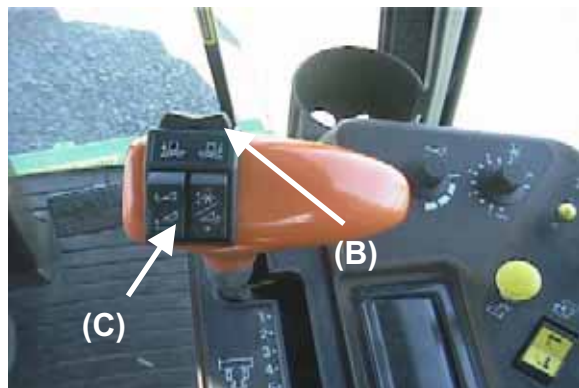

(Flex Platforms) Raise the header completely off the ground so that both skid shoes are hanging completely down. It is not necessary for the platform to match the ground contour.

4. While pushing the header raise button (C) on the hydro-handle turn the automatic lateral header tilt switch to (A) auto. The difference in the left and right signals is stored until this same procedure is repeated.



## LT-100 AUTOMATIC OPERATION

With the header engaged, switch the Hillco LT-100 switch (A) to the ON position. The header will then automatically follow the contour of the ground using non-contact sensors on the rigid platforms and corn heads and contacting sensors on flex platforms.



*NOTE: It is not necessary to engage the separator for the system to operate.*

The automatic function will shut off if any of the following happens:

1. Header disengages.
2. Operator is off seat for more than five seconds.
3. Tilt switch is turned off.
4. The header harness is disconnected.
5. The header is raised for more than 1-1/2 seconds.

## HILLCO LT-100 MANUAL OPERATION

To manually tilt the header, switch the Hillco switch (A) to the off position. Press the right half of the switch (B) to tilt it right. Press the left half of the switch (B) to go left.

*NOTE: The manual switch can be used during automatic operation, but as soon the manual switch is released, the automatic mode will re-adjust.*

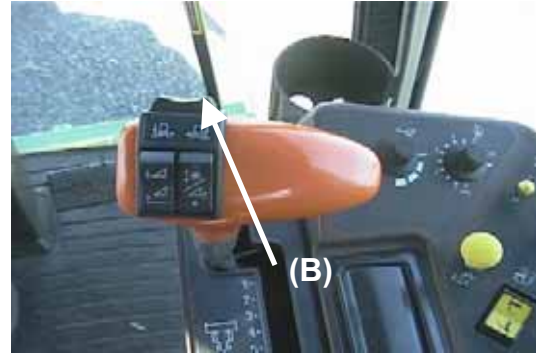
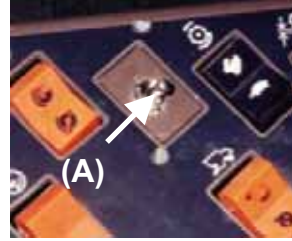

## HILLCO LT-100 SENSITIVITY ADJUSTMENTS

The sensitivity of the Hillco LT-100 can be adjusted by changing the switch positions on the JD Contour Master™ circuit board located in the central electronics box.

If the header seems to be too sensitive in the side-to-side motion, you can choose a less sensitive switch setting. If the header doesn't seem sensitive enough, you can try a more sensitive switch setting.

*NOTE: Switch #1 & #5 are always off.*

SWITCH 1	SWITCH 2	SWITCH 3	SWITCH 4	SWITCH 5	RESPONSIVENESS
OFF	OFF	OFF	OFF	OFF	LEAST
OFF	ON	OFF	OFF	OFF	
OFF	OFF	ON	OFF	OFF	MEDIUM
OFF	OFF	OFF	ON	OFF	
OFF	ON	ON	ON	OFF	MOST

Contour Master™ circuit board switch settings

## SERVICING THE HILLCO LT-100

Grease the tilt cylinder ends every 50 hours.



# PARTS

## HILCO LT-100 HEADER ADAPTER

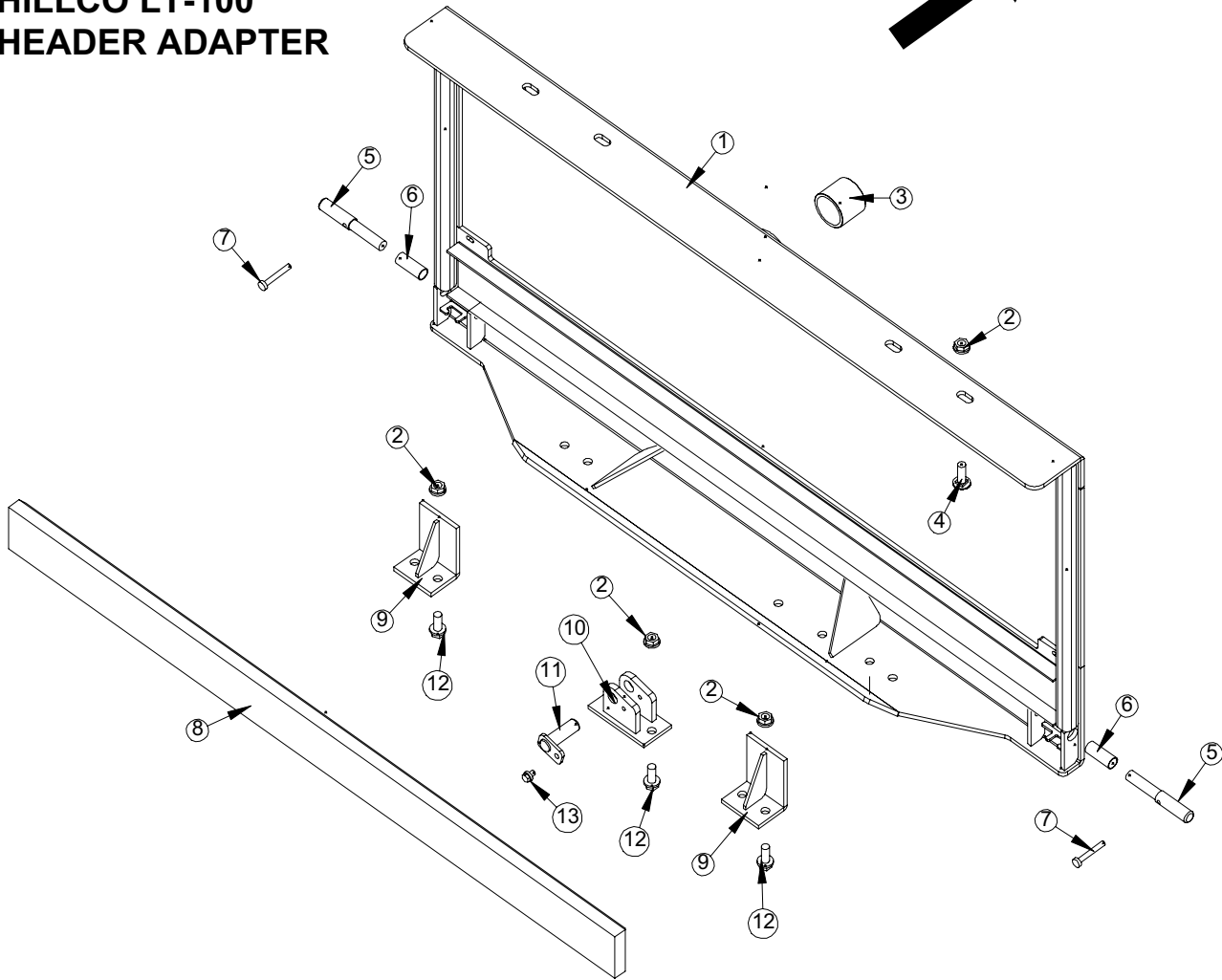
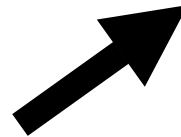

KEY	PART NUMBER	PART NAME	QTY.	REMARKS
1	LTA-241281	LTA ASM, LATERAL TILT	1	
2	F-HNF-16ME	M16 FLANGED NUT	10	
3	LTP-241721	BUSHING	1	
4	F-CB-16M045E	M16 X 45 CARRIAGE BOLT	4	
5	LM-229192	TM ROD, LOCK	2	
6	MC-135531	SPRING	2	
7	F-HC-10M070F	M10 X 70 FLANGE BOLT	2	
8	LTP-241751	UHMW PLASTIC, WEAR PAD	1	
9	LTA-241541	LTM ASM, STOP	2	
10	LTA-241571	LTM ASM, CYL MOUNT	1	
11	LTA-248541	TM PIN ASM	1	
12	F-HCF-16M040E	M16 X 40 FLANGE BOLT	6	
13	F-HCF-10M016F	M10 X 16 FLANGE BOLT	1	

# LT-100 OPERATORS AND PARTS MANUAL

D-030528CLA01 REV2

## HILLCO LT-100 THROAT

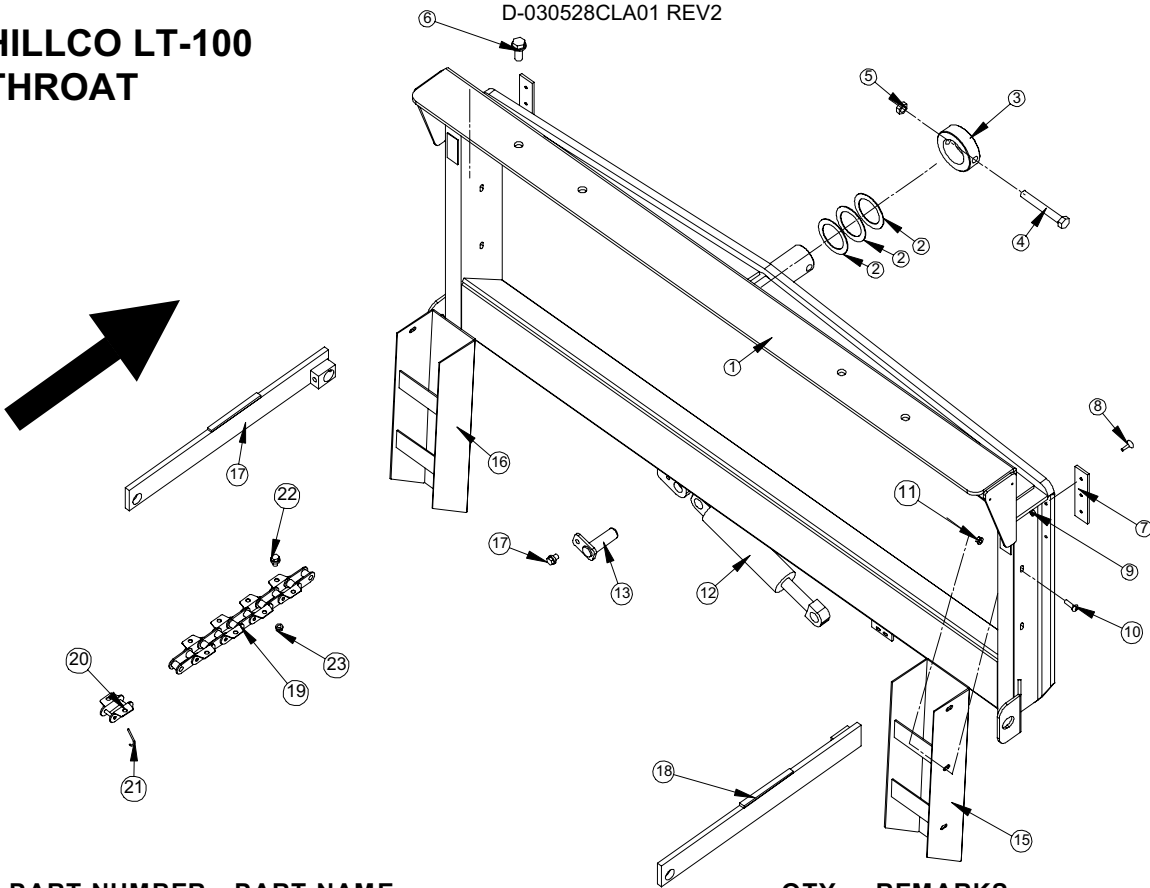

KEY	PART NUMBER	PART NAME	QTY.	REMARKS
1	LTA-241422	LTT ASM	1	
2	F-MB-14NR40	MACHINE BUSHING	As Req.	
3	LM-226841	TM COLLAR, PIVOT	1	
4	F-HC-16M120E	M16 X 120 BOLT	1	
5	F-HNS-16ME	M16 STOVER NUT	1	
6	F-HCF-12M040E	M12 X 40 FLANGE BOLT	4	9000 & 10 SERIES
	F-HCF-16M040E	M16 X 40 FLANGE BOLT	4	50 SERIES
7	LTM-242181	LTM UHMW, TOP WEAR PAD	2	
8	F-FHS-6M020E	M6 X 20 HEX SOCKET CAP	6	
9	F-HNN-6ME	M6 NYLOCK NUT	6	
10	F-CB-8M030E	M8 X 30 CARRIAGE BOLT	6	
11	F-HNF-08ME	M8 FLANGE NUTS	6	
12	HC-136811	CYLINDER	1	
	HC137231	SEAL KIT, CYLINDER		
13	LA-229071	TM PIN ASM	1	
14	F-HCF-10M016F	M10 X 16 FLANGE BOLT	1	
15	LTA-241653	LTM ASM, RH THROAT FILLER	1	
16	LTA-241683	LTM ASM, LH THROAT FILLER	1	
17	LTA-242251	LTM ASM, FEEDER DRUM ARM LH	1	
18	LTA-242221	LTM ASM, FEEDER DRUM ARM RH	1	
19	MC-136871	FEEDER CHAIN EXTENSION	3	4 USED ON 9600, 9610 & 9650
20	MC-137021	CONNECTOR LINK	3	4 USED ON 9600, 9610 & 9650
21	MC-137031	S-WIRE KEEPER PIN	8	12 USED ON 9600, 9610 & 9650
22	F-HC-8M016F	M8 X 16 BOLT	As Req.	
23	F-HNS-8ME	M8 STOVER NUT	As Req.	

### NOT SHOWN

	LL-136801	DECAL, LARGE HILLCO LT-100	1	TOP OF TRASITION
	LL-136791	DECAL, SMALL HILLCO LT-100	2	SIDES OF TRASITION
	LL-137051	DECAL, DANGER-PINCH POINT HAZARD	2	SIDES OF TRASITION

**HILLCO LT-100  
SHIELD AND HEX  
DRIVE ADAPTER**

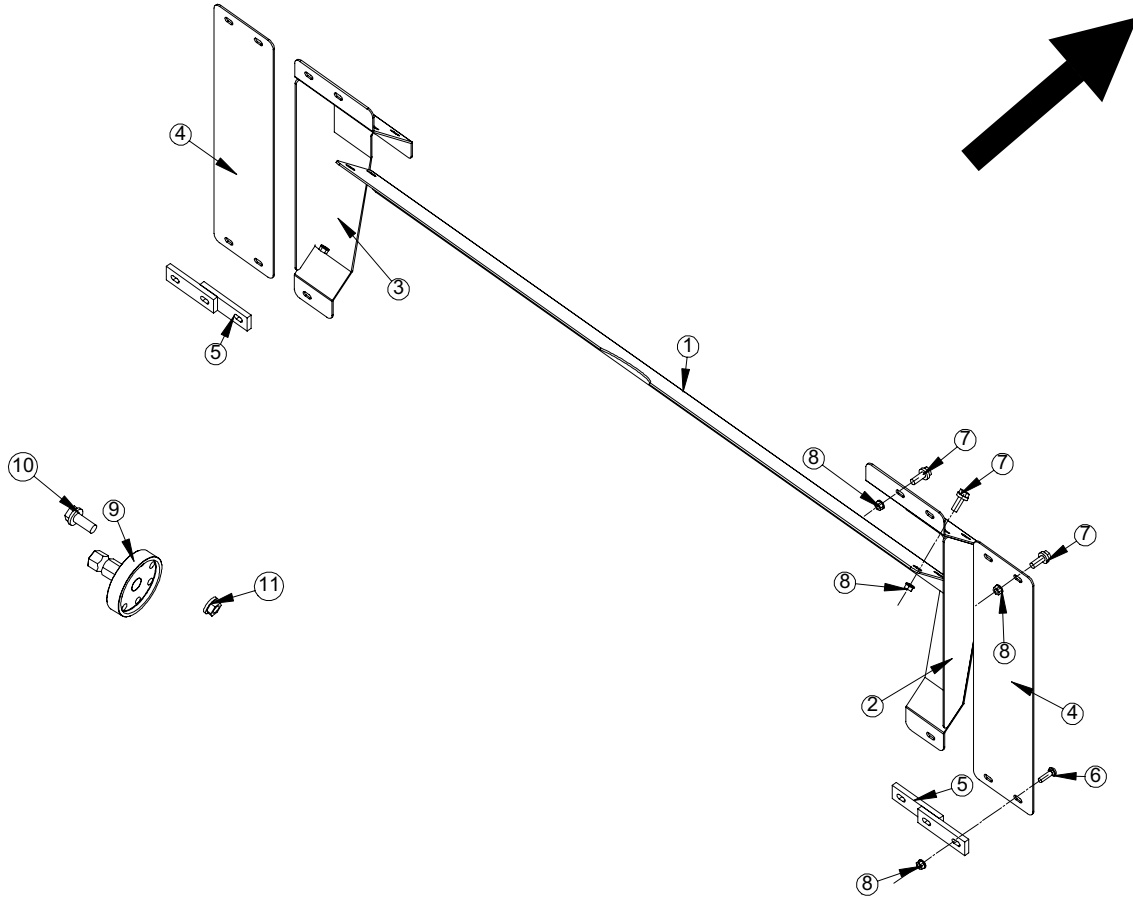

KEY	PART NUMBER	PART NAME	QTY.	REMARKS
1	LTP-241741	LTM PLT, SHIELD TOP	1	
2	LTA-241602	LTM ASM, RH SHIELD	1	
3	LTA-241632	LTM ASM, LH SHIELD	1	
4	LTP-241731	LTM PLT, SHIELD EXT	2	
5	LTA-241701	LTM ASM, SHIELD EXT SUPPORT	2	
6	F-CB-8M030E	M8 X 30 CARRIAGE BOLT	6	
7	F-HCF-8M020E	M8 X 20 FLANGE BOLT	12	
8	F-HNF-08ME	M8 FLANGE NUT	18	
9	LTA-242191	LTM ASM, HEX DRIVE ADAPTER	1	
10	F-HCF-12M040E	M12 X 40 FLANGE BOLT	7	9600 ONLY
11	F-HNN-12ME	M12 FLANGE NUT	7	9600 ONLY

**HILCO LT-100  
VALVE AND HOSES**

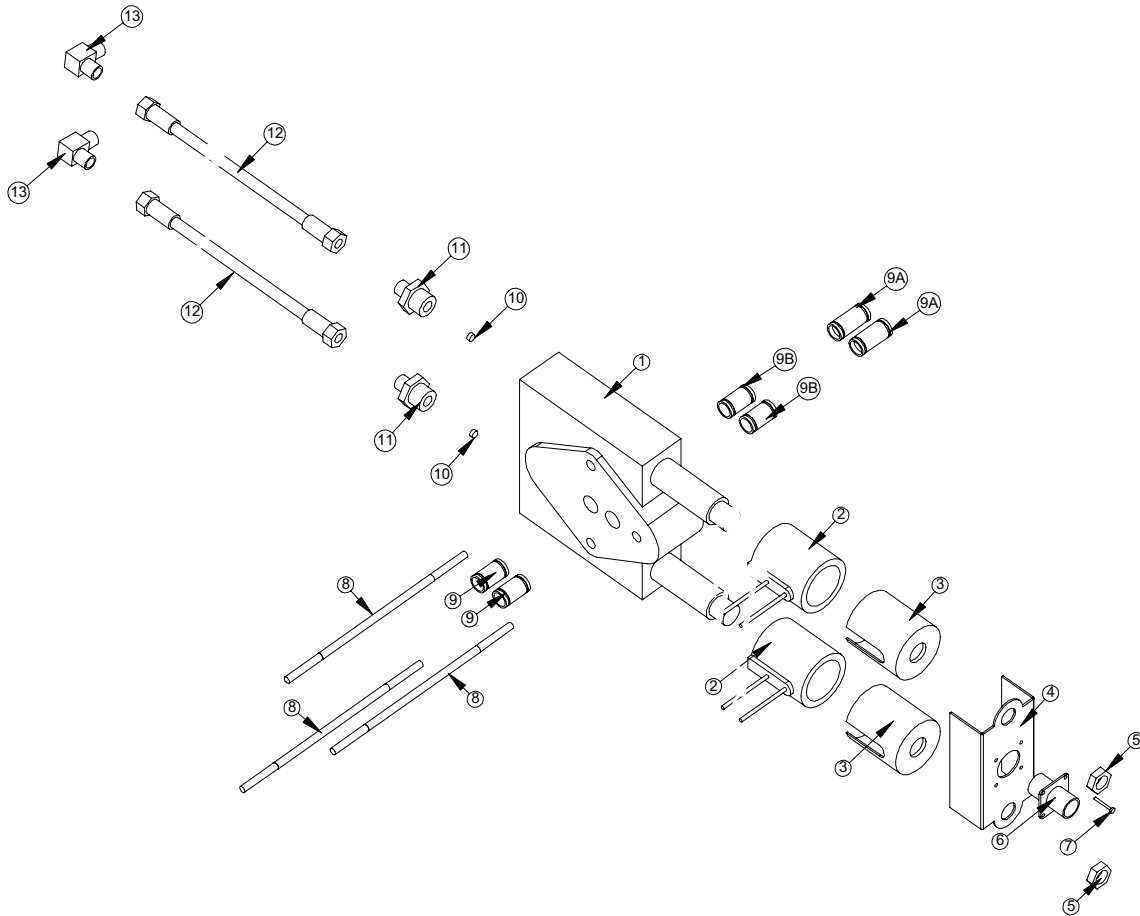

KEY	PART NUMBER	PART NAME	QTY.	REMARKS
1	HC-136511**	LATERAL TILT VALVE	1	COMPLETE MAIN BODY W/ INTERNAL PARTS
2	HC-136561	COILS	2	
3	HC-136571	COIL COVERS	2	
4	HC-136591	COVER	1	9000 & 10 SERIES ONLY
5	HC-136581	COIL COVER NUTS	2	
6	EC-136721	AMP 4-PIN CONNECTOR	1	9000 & 10 SERIES ONLY
7	MC-136841	#6 x 1/4 SCREW	4	9000 & 10 SERIES ONLY
8	LP-248471	TIE ROD BOLT	3	
9	HC-136551	SHORT THROUGH TUBES	2	
9A	HC-136541	LONG THROUGH TUBES	2	9000 & 10 SERIES ONLY
9B	HC-136551	SHORT THROUGH TUBES	2	50 SERIES ONLY
10	HC-136521	ORIFICE	2	
11	HA-S-4MF8MO	ADAPTER	2	#8MORB X #4 MORS STR.
12	LTA-242261	HOSE	2	1/4" 100R2 HOSE 249" #4 FORS BOTH ENDS
13	HA-L-4MF4MO	ADAPTER	2	#4MORB X #4MORS 90 DEG.

\*\*FOR INTERNAL PARTS FOR THE HC-136511 VALVE SEE YOUR JD DEALER, IT IS THE EXACT SAME VALVE AS THE JD CONTOUR MASTER™ VALVE.

**HILLCO LT-100  
ELECTRICAL**



KEY	PART NUMBER	PART NAME	QTY.	REMARKS
1	LTA-242281	LTM CABLE FOR DUMP VALVE	1	
2	LTA-242271	LTM CABLE MAIN W/ DIODES	1	
3	LTA-242291	LTM CABLE FOR OLDER JD COMBINES	1	MANUAL LATERAL TILT ONLY FOR 1994 AND OLDER COMBINES
4	LTA-243931	AUTO LATERAL TILT CABLE ASSEMBLY	1	AUTO LATERAL TILT FOR 1994 AND OLDER COMBINES

**NOT SHOWN**

	MC-136601	AMP TERMINAL EXTRACTION TOOL		FOR REMOVAL OF AMP TERMINALS
--	-----------	------------------------------	--	------------------------------