



Model 2810
Leveling System
Operator's Manual
S/N 2810-16001 - 2810-16999
(D-050511DJC01H)

TABLE OF CONTENTS



2000 Series Operator Manual Model 2810 Leveling System

SERIAL NUMBER LOCATION	4
WARRANTY REGISTRATION	5
WARRANTY POLICY	6
INTRODUCTION	7
SAFETY	8
SAFETY ALERT SYMBOL.....	8
OPERATION SAFETY	9
HYDRAULIC SAFETY.....	9
SERVICING AND MAINTENANCE SAFETY	9
HIGHWAY OPERATION AND TRANSPORT SAFETY	10
SAFETY LABELS.....	10
SAFETY LABEL LOCATIONS	11
SAFETY LABEL LOCATIONS	12
SAFETY LABEL SPECIFICATIONS	13
OPERATION, SETUP, AND MAINTENANCE.....	14
LEVELING SYSTEM CONTROLS.....	14
REAR WHEEL ASSIST WARNING ALARM.....	16
OPERATOR ADJUSTMENTS.....	17
ALARM TRIP ANGLE ADJUSTMENT.....	18
LEVELING ZERO POINT ADJUSTMENT	19
MANUAL LEVELING SPEED ADJUSTMENT	20
MONITOR CONTRAST ADJUSTMENT.....	21
MONITOR BRIGHTNESS ADJUSTMENT	22
ELECTRICAL SETTINGS	23
LIMIT SWITCHES AND MAXIMUM LEVEL LAMP.....	23
HOW TO SET LIMIT SWITCHES.....	23
LEVEL LIMIT STOPS	24
LEVELING CONTROLLER FUNCTION.....	24
MECHANICAL ADJUSTMENTS	25
MODEL 2810 TREAD WIDTH – Slope Restrictions.....	25
TIRE SELECTION – Slope Restrictions.....	25
FEEDER ADJUSTMENT FOR TIRE SIZE	25
CONVEYOR DRUM FORE / AFT POSITION	26
HEADER AND COMBINE CONNECTION	26
REAR AXLE WEIGHTING	26
REAR AXLE TOE IN.....	27
FEEDER CONVEYOR SLIP CLUTCH.....	27
TRANSITION DRIVE CHAIN	27
SHAFT STRIPPERS & NARROWING PLATES	27

TABLE OF CONTENTS

LADDER	29
LEVELING CYLINDER SAFETY STOPS.....	29
GENERAL SHIELDING.....	29
HYDRAULIC SETTINGS.....	29
PRESSURE COMPENSATOR SETTING (36' Draper Headers Only).....	30
HYDRAULIC HOSES	30
HYDRAULIC CYLINDERS	30
GREASE LOCATIONS.....	31
GREASE LOCATIONS.....	32
GREASE LOCATIONS.....	33
FASTENERS.....	34
METRIC TORQUE CHART	35
STANDARD TORQUE CHART	36
TIRE INFLATION	37
SCHEMATICS.....	38
2810 ELECTRICAL CIRCUIT SCHEMATIC.....	38
2810 HYDRAULIC CIRCUIT SCHEMATIC	39

SERIAL NUMBER LOCATION

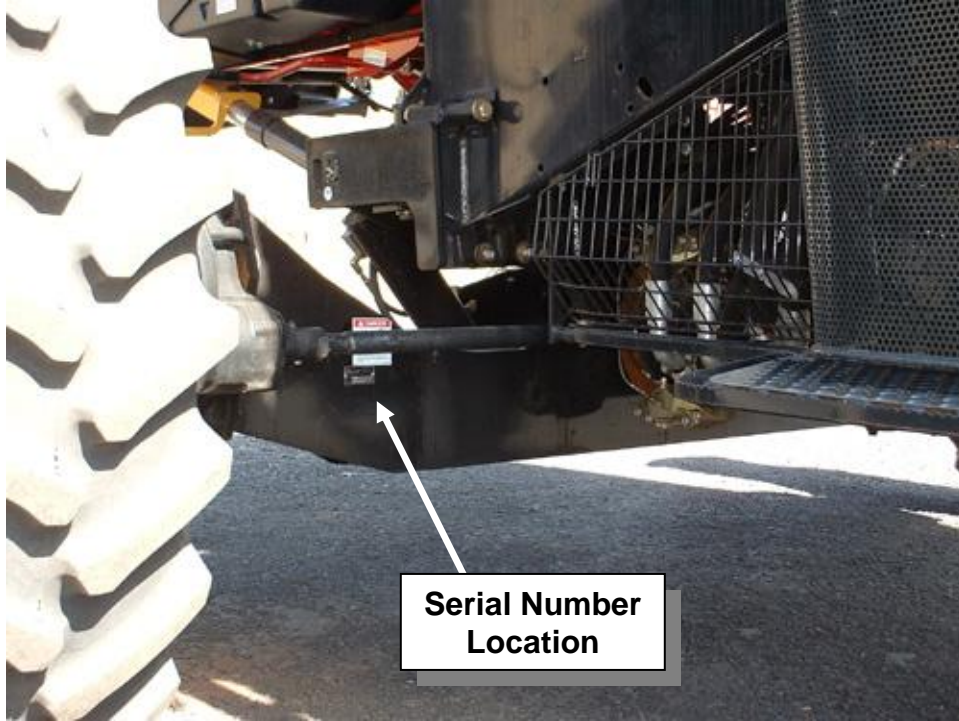

Write the serial number of the combine and the Leveling System on the lines provided. Give these numbers to your dealer when you need parts or information for your machine.

COMBINE SERIAL NUMBER

LEVELING SYSTEM SERIAL NUMBER

WARRANTY REGISTRATION

OWNER'S OBLIGATION

WARRANTY REGISTRATION You must complete the Warranty Registration Card and submit it to Hillco Technologies, Inc. within thirty (30) days of the date of delivery to register the new equipment under Hillco's Warranty Policy.

Warranty Void if not Registered!

MAINTENANCE SERVICE The operator's manual furnished to you with the equipment at the time of delivery contains important maintenance and service information. You should read the manual carefully and follow all maintenance and service recommendations. Doing so will result in greater satisfaction with your equipment and help to avoid service and warranty problems. Please remember that failures due to improper maintenance of your equipment are not covered by warranty.

The 2810H is compatible with all Case-IH heads up to the weight limit of 8510 lbs. Hillco does not guarantee any non Case-IH header applications and will not be responsible for any damage occurred from improper header configurations.

Please call Hillco Technologies if you have any questions regarding the 2810H or any other header configuration.

WARRANTY POLICY



Statement of Limited Warranty (North American Harvest Products)

Hillco Technologies, Inc. (Hillco) warrants its new products to be free from defects in material and workmanship for a period of twelve (12) consecutive months following the warranty start date.

The warranty start date for Hillco products invoiced by Hillco from October 1st through May 31st is the first day of June following the Hillco invoice date, or the first date of use, whichever is earliest. For Hillco products invoiced by Hillco from June 1st through September 30th the warranty start date is the date of invoice. Once the warranty period has begun, it cannot be stopped or interrupted.

Hillco's obligation under this warranty shall be limited to repairing or replacing, free of charge to the original purchaser, any part that, in Hillco's judgment, shows evidence of such defect. Hillco additionally agrees to repair, at no cost to the original purchaser, any physical damage to the product to which the Hillco product is directly attached provided that the damage is directly attributable to a defect in the design or manufacture of the Hillco product, as determined by Hillco, and that the damage occurs during the effective warranty period of the Hillco product.

Hillco warrants genuine Hillco replacement parts and components to be free from defects in material and workmanship for a period of ninety (90) consecutive days following the Hillco invoice date, or the remainder of the original equipment warranty period, whichever is longer.

Limitations to Warranty

This warranty does not cover:

- 1) Any product damaged by accident, abuse, misuse, negligence, or improper maintenance.
- 2) Any unauthorized product alteration or modification.
- 3) Any unauthorized repairs made with parts other than genuine Hillco parts unless specifically authorized by Hillco.
- 4) Any repairs performed by anyone other than Hillco or an authorized Hillco dealer unless specifically authorized by Hillco.
- 5) Any claims directly resulting from improper installation, except those installations performed by Hillco.

Warranty Procedure

A Hillco Warranty Registration Form must be fully completed and returned to Hillco within 30 days of sale of the product to the retail customer or the first day of use, whichever is earlier.

All warranty claims must be submitted on a fully completed Hillco Warranty Claim Form.

All warranty work must be performed, and claims submitted, within thirty (30) days of the occurrence of the claim and within the warranty period.

All parts removed during warranty repair should be held for a period of sixty (60) days after the warranty claim has been submitted to Hillco.

Hillco reserves the right to either inspect the product at the original retail purchaser's location, or the authorized Hillco dealer's location; or require it to be returned to Hillco, transportation charges prepaid, for inspection.

Limitation of Liability

Hillco makes no express warranties other than those, which are specifically described herein. Any description of the goods sold hereunder, including any reference to buyer's specifications and any descriptions in circulars and other media published by Hillco is for the sole purpose of identifying such goods and shall not create an express warranty that the goods shall conform to such description.

THIS WARRANTY IS EXPRESSLY IN LIEU OF ALL OTHER WARRANTIES EXPRESSED OR IMPLIED. There are no implied warranties of merchantability or fitness for a particular purpose. This warranty states Hillco's entire and exclusive liability and buyer's exclusive remedy for any claim for damages in connection with the sale or furnishing of Hillco products, their design, suitability for use, installation, operation, or for any claimed defects herein. **HILLCO WILL IN NO EVENT BE LIABLE FOR ANY INCIDENTAL OR CONSEQUENTIAL DAMAGES WHATSOEVER, NOR FOR ANY SUM IN EXCESS OF THE PRICE RECEIVED FOR THE GOODS FOR WHICH LIABILITY IS CLAIMED.**

No representative of Hillco nor any dealer associated with Hillco has the authority to change the items of this warranty in any manner whatsoever, and no assistance to purchaser by Hillco in the repair or operation of any Hillco product shall constitute a waiver of the conditions of this warranty, nor shall such assistance extend or revive it.

Hillco reserves the right to make improvements in design or changes in specifications at any time, without incurring any obligation to owners of units previously sold.

INTRODUCTION

Thank you for choosing the Hillco 2000 Series Leveling System to compliment your farming operation. This product has been designed and manufactured to meet the needs of a discriminating buyer for increasing the performance of a combine.

Safe, efficient and trouble free use of your Hillco 2000 Series Leveling System requires that you and anyone else who will be operating or maintaining the leveling system, read and understand the safety, operation, and maintenance information contained in the Operator's Manual.

If extra copies of the operator's manual are needed, contact Hillco at 1-800-937-2461 and ask for the document number found on the front cover page.



HILLCO MODEL 2810 LEVELING SYSTEM

This manual covers the Hillco 2000 Series Model 2810 (for the Case IH AFX 8010, 8120 or 9120 combines) Leveling System built by Hillco. Use the Table of Contents as a guide when searching for specific information.

Keep this manual handy for frequent reference and to pass on to new operators or owners. Call your Hillco dealer or Hillco if you need assistance or information at 1 (800) 937-2461.

OPERATOR ORIENTATION – The directions left, right, front, and rear, as mentioned throughout this manual, are as seen from the combine operator's seat and facing in the direction of forward travel.

SAFETY ALERT SYMBOL

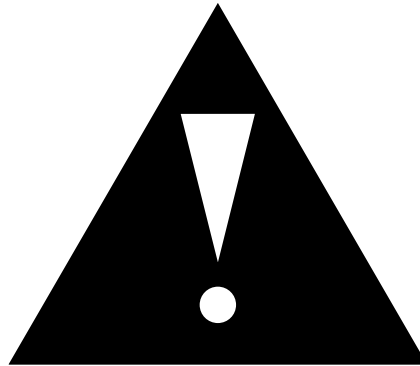

This Safety Alert symbol means
ATTENTION! BECOME ALERT! YOUR SAFETY IS INVOLVED!

The Safety Alert symbol identifies important safety messages on the Hillco 2000 Series Leveling System and in the manual. When you see this symbol, be alert to the possibility of personal injury or death. Follow the instructions in the safety message.

SIGNAL WORDS

Note the use of the signal words **DANGER**, **WARNING**, and **CAUTION** with the safety messages. The appropriate signal word for each message has been selected using the following guidelines:

DANGER - An immediate and specific hazard, which **WILL** result in severe personal injury or death if the proper precautions are not taken.

WARNING - A specific hazard or unsafe practice, which **COULD** result in severe personal injury or death if proper precautions are not taken.

CAUTION - Unsafe practices which **COULD** result in personal injury if proper practices are not taken, or as a reminder of good safety practices.

OPERATION SAFETY

1. Read and understand the Operator's Manual and all safety labels before operating the leveling system.
2. Make sure that all controls are in the manual position before starting the combine.
3. Clear the area of all bystanders, especially children, before starting the leveling system and during operation.
4. Make sure all safety shields are in place before operating the combine. Never operate the machine with the shields removed.
5. Keep hands, feet, hair and clothing away from all moving and/or rotating parts.
6. Stay seated in the cab during operation.
7. Operate controls only when sitting in the seat of the combine.
8. To avoid engine damage, do not run the machine for extended periods of time when it is in the leveled over position.
9. Always travel at a safe speed. Use caution when making turns or traversing ditches.
10. The leveling system is equipped with a maximum level warning lamp. This lamp indicates when the machine has reached its maximum leveling capability. There are restrictions as to tread width and tire selection for combines used in harvesting slopes greater than the maximum leveling capability of the leveling system. Refer to page 13 for important information on these restrictions.
11. The use of after-market grain tank extensions is prohibited from use on combines equipped with the Model 2810 leveling system.
12. Level Limit Stops should be used on combines that rely on the limit switches to stop the leveling prematurely to prevent sheet metal damage (Refer to Page 14).

HYDRAULIC SAFETY

1. Do not search for high-pressure hydraulic leaks without hand and face protection. A tiny, almost invisible leak can penetrate skin, thereby requiring immediate medical attention.
2. Use cardboard or wood to detect leaks – never your hands!
3. Double check that all is clear before operating hydraulics.
4. Maintain proper hydraulic fluid levels.
5. Ensure all fittings and hoses are in good repair.
6. Do not make any repairs to the leveling system hydraulic system including: cylinders, valves, hydraulic hoses, adapters, pumps, manifolds, or reservoirs without first contacting you authorized Hillco dealer. These hydraulic components stabilize the chassis of the combine. Improper repair or replacement of these components could lead to uncontrolled leveling of the combine's chassis.

SERVICING AND MAINTENANCE SAFETY

1. Review the Operator's Manual and all safety items before servicing or maintaining the leveling system.
2. Place the Auto/Off/Manual leveling switch in the "Off" position, stop the combine engine, wait for any moving parts to stop, block the tires, the header, and the cylinder areas before servicing, repairing, adjusting, or maintaining the leveling system.
3. Hydraulic oil is under pressure. Use caution when dealing with the hydraulic system.
4. Keep hands, feet clothing and hair away from all moving and/or rotating parts.
5. Clear the area of bystanders, especially children, when carrying out any maintenance, repairs or making any adjustments.

HIGHWAY OPERATION AND TRANSPORT SAFETY

1. Check with local authorities regarding combine transport on public roads. Obey all applicable regulations and laws.
2. Check clearance elevations and widths of combine for travel near power lines, bridges, trees, etc.
3. Make sure the Auto/Off/Manual leveling toggle switch is in the “Off” position for all transport and highway travel situations.
4. Always travel at a safe speed. Use caution when making corners or meeting traffic.

SAFETY LABELS

Familiarize yourself with the location of all safety labels. Read them carefully to understand the safe operation of your machine.

“Read Operator’s Manual” Symbol

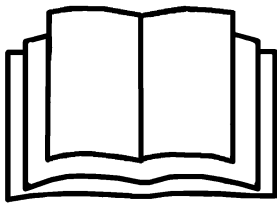

Decals, which display the “Read Operator’s Manual” symbol, are intended to direct the operator to the Operator’s Manual for further information regarding maintenance, adjustments and/or procedures for particular areas of the leveling system. When a decal displays this symbol refer to the Operator’s Manual for further instructions.

TO APPLY NEW OR REPLACEMENT LABELS:

1. Make sure the label area is smooth by removing any debris such as dirt or old labels.
2. Wash the area with soap and water and then dry it thoroughly.
3. After the area has completely dried, peel the backing off the safety label and place it onto the cleaned area.
4. Make sure all areas of the label have adhered to the machine by pressing down on the entire face of the label, including the corners.

SAFETY LABEL LOCATIONS



SAFETY LABEL LOCATIONS

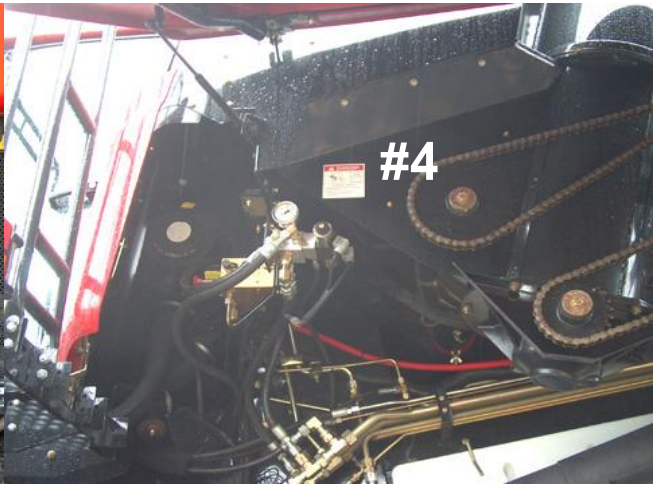
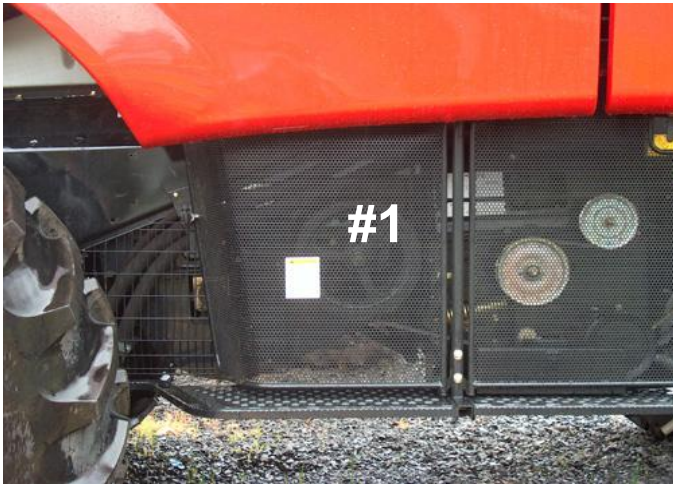

SAFETY LABEL SPECIFICATIONS

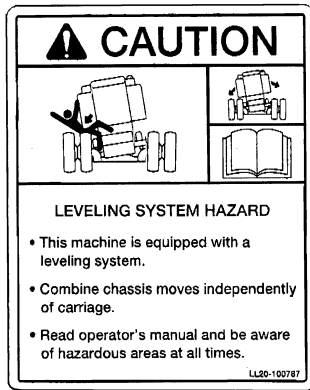

Label #1
Part number: LL20-100787
Locations: 2 (Left side on shield; Right side on elevator)



Label #2
Part Number: LL20-100783
Locations: 4 (Rear of undercarriage, and above rear axle)



Label #3
Part number: LL20-10784
Locations: 2 (Left and right side of upper transition face plate)

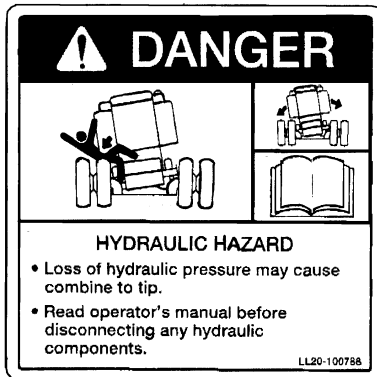

Label #4
Part number: LL20-100788
Locations: 3 (Main cylinders and above leveling manifold)



Label #5
Part number: LL20-100786
Locations: 1 (Front of electrical box)

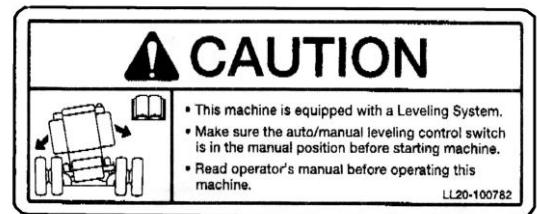

Label #6
Part number: LL20-100782
Locations: 1 (Inside cab window beyond console)



Label #7
Part number: LL20-100785
Locations: 1 (ladder well)

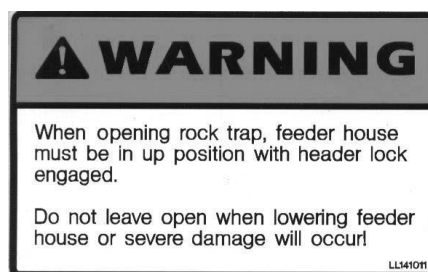

Label #8
Part number: LL-141011
Locations: 2 (Left Feeder Drive Shield and by Rock Trap Door Lever)



Label #9
Part number: LL-143621
Locations: 2 (Front of under carriage)

These safety labels should be present and legible at all times. If new labels are needed, or you have any questions concerning safety, please contact Hillco at 1-800-937-2461.

OPERATION, SETUP, AND MAINTENANCE

LEVELING SYSTEM CONTROLS

The leveling controls on the main page are shown below. The R/F (Road/Field) button must be in the F (Field) selection for the other buttons to function. If it is in the R (Road) selection then none of the other buttons will function. Pushing the button once will toggle the selection between R & F.

LEVEL LEFT: Push down and hold the Manual L (Left) Button.

LEVEL RIGHT: Push down and hold the Manual R (Right) Button.

AUTO: Pushing the A/M (Auto/Manual) Leveling Button once will toggle between A & M. When the A (Auto) is showing on the display, this means automatic leveling operation is engaged. The automatic leveling controller monitors changes in slope and corrects chassis position to maintain a level chassis position. The Manual Left/Right Leveling Buttons will override the automatic leveling controller while the switch is depressed. Upon release of the switch, the leveling system will return to automatic leveling mode.

MANUAL: Push the A/M (Auto/Manual) Leveling Button once to enter the Manual Leveling mode (M will be displayed). In Manual mode the Manual Left/Right leveling switches will level the combine left and right. When the switch is released the combine chassis will maintain its current position.

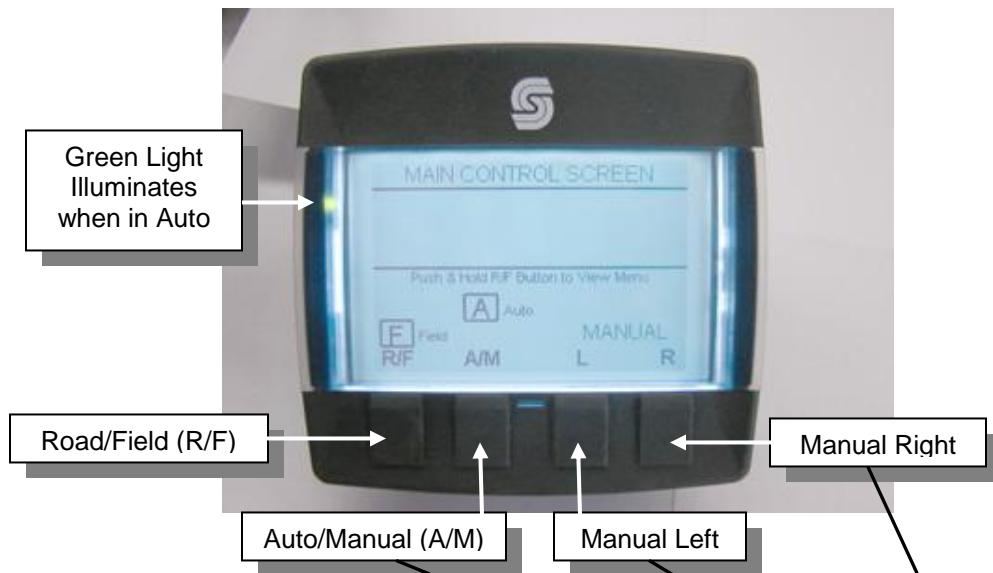

Remote Leveling Switches: Located above the Pro 600 monitor are remote leveling switches. These switches allow for Auto/Manual control and Left/Right leveling.

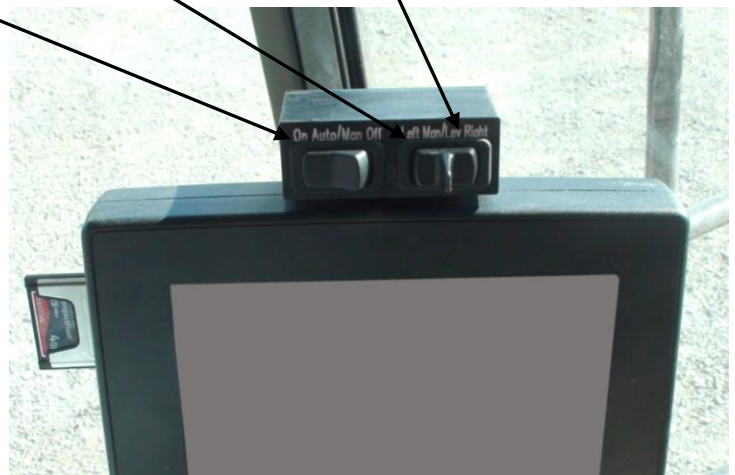

Leveling System Controls-Continued

The leveling system is equipped with a maximum level warning indicator on the monitor. On the Main Control Screen MAXIMUM LEVEL will be displayed and the lower right red LED will illuminate. This indicates when the machine has reached its maximum leveling capability. Important tire and tread width restrictions apply to the use of combines equipped with the Model 3700H Leveling system that are intended for use on slopes exceeding the maximum leveling capability. See the “Slope Restrictions” section of this manual for important details of these restrictions.



HEADER TRIM SWITCH

The header trim switch is the four-position header control switch mounted in the combine's SR control lever. It is used to raise and lower the header as well as trim the header left and right.

- TILT LEFT:** Push the switch to the left to tilt the header counterclockwise.
TILT RIGHT: Push the switch to the right to tilt the header clockwise



REAR WHEEL ASSIST WARNING ALARM

The Rear Wheel Assist (RWA) Warning Alarm is located in the Leveling System Control Monitor in the right corner of the cab. It will sound an alarm, a warning light will flash and RWA/SLOPE WARNING will be displayed on the monitor if the combine is traversing down a slope that is greater than 20% and the Rear Wheel Assist is engaged. Disengage the Rear Wheel Assist and the warning alarm and light will stop. On downhill slopes less than 20%, level ground or uphill slopes the alarm will never sound if RWA is engaged.

See your combine's Operator's Manual to understand how to operate the Rear Wheel Assist (RWA).

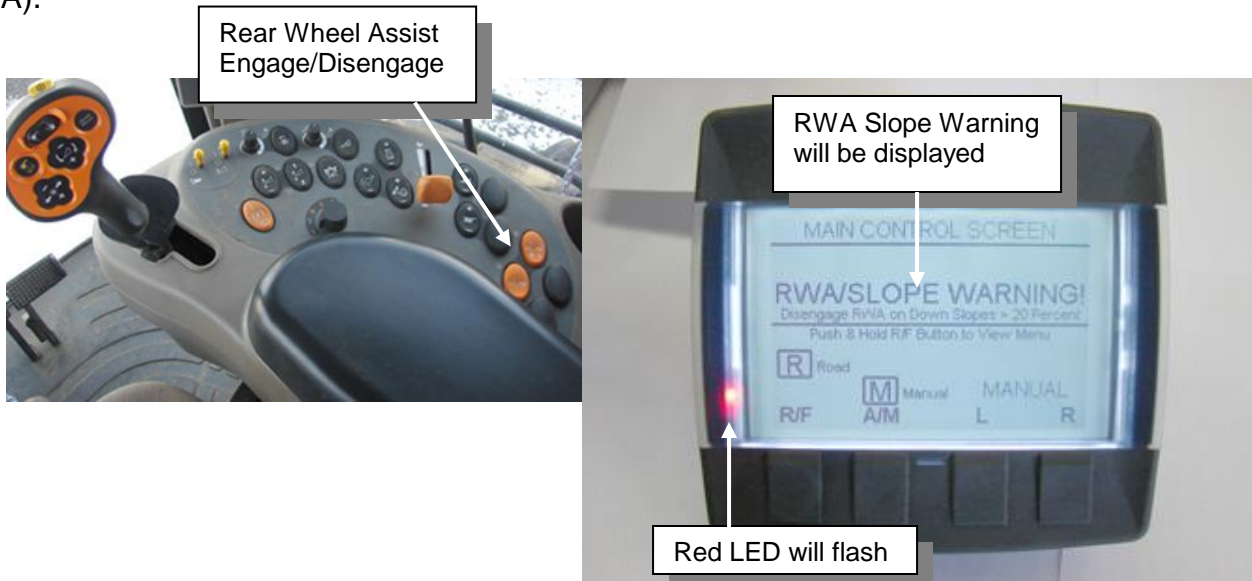

WARNING!

When the Rear Wheel Assist Warning Alarm Sounds and Warning Light Flashes **IMMEDIATELY DISENGAGE** the Rear Wheel Assist or Control of the Combine **COULD** be lost.

OPERATOR ADJUSTMENTS

From the Main Control Screen, Push & Hold the R/F button for two (2) seconds to go the Menu Screen.

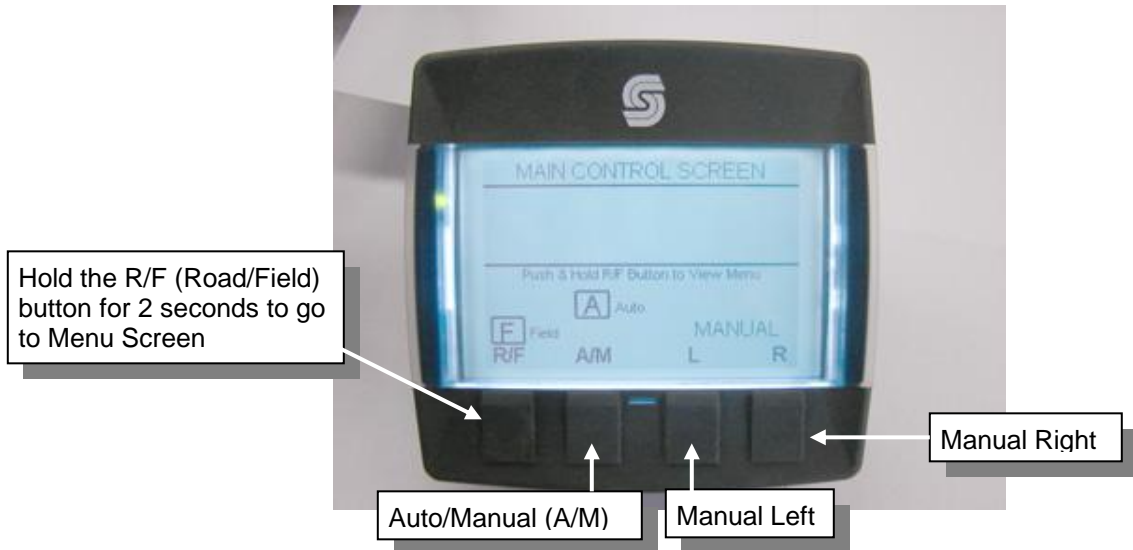

Push the **UP** or **DN** buttons to move the **X** to the Operator Adjustments Line and then push the **ENT** button to go into that Page. Note: Pushing the **ESC** button will take you back to the Main Control Screen.

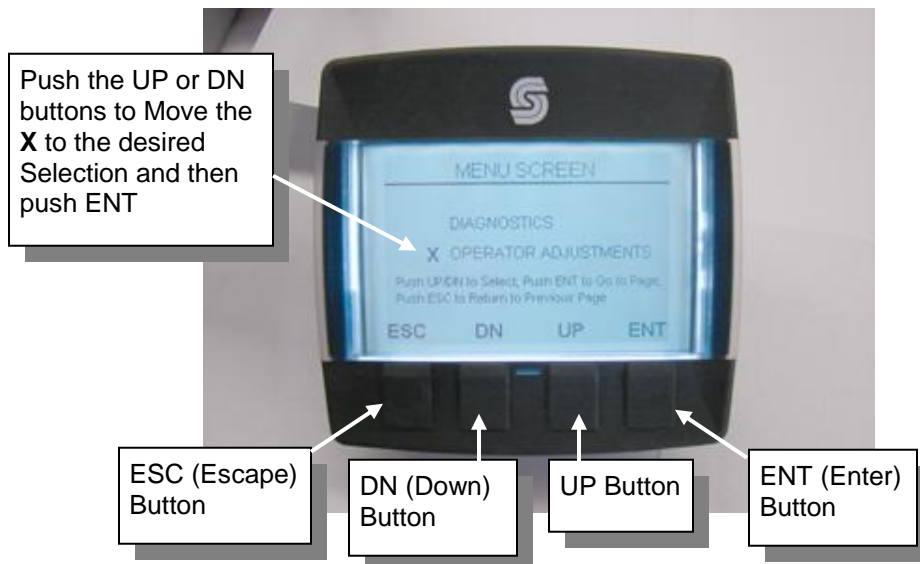

ALARM TRIP ANGLE ADJUSTMENT

From the Operator Adjustments Screen, Push the **UP** or **DN** buttons to move the **X** to the RWA Alarm Trip Angle and push **ENT**. Note: Pushing the **ESC** button will take you back to the Menu Screen.

Push the UP or DN buttons to Move the **X** to the desired Selection and then push ENT



Once in the Alarm Trip Angle Page push and hold the **ENT** button for one (1) second to set the Alarm Trip Angle. This is a one (1) time adjustment unless tire size increases/decreases or the clinometer is replaced. Push **ESC** to leave the page. Note: Pushing the **ESC** button will take you back to the Operator Adjustments Screen.



LEVELING ZERO POINT ADJUSTMENT

From the Operator Adjustments Screen, Push the **UP** or **DN** buttons to move the **X** to the Level Zero Point and push **ENT**. Note: Pushing the **ESC** button will take you back to the Menu Screen.

Push the UP or DN buttons to Move the **X** to the desired Selection and then push ENT



Once in the Level Zero Point Screen place a level on the cab floor. Manually level the combine to the left (**L**) or right (**R**) until the bubble shows level. Push and hold the **ENT** button for 1 second. This will set the Zero Point for Leveling. This is a one (1) time adjustment unless the clinometer or controller has been replaced. When done push the **ESC** button to leave the page. Note: Pushing the **ESC** button will take you back to the Menu Screen.



MANUAL LEVELING SPEED ADJUSTMENT

From the Operator Adjustments Screen, Push the **UP** or **DN** buttons to move the **X** to Manual Leveling Speed and push **ENT**. Note: Pushing the **ESC** button will take you back to the Menu Screen.

Push the UP or DN buttons to Move the **X** to the desired Selection and then push ENT



Once in the Manual Leveling Speed Screen, push the **UP** or **DN** buttons to increase or decrease the manual leveling speed (Default Setting is 13). Once the desired setting is reached on the bar graph, push and hold the **ENT** button for 1 second. This will lock the new manual leveling speed setting. When done push the **ESC** button to leave the page. Note: Pushing the **ESC** button will take you back to the Menu Screen.



MONITOR CONTRAST ADJUSTMENT

From the Operator Adjustments Screen, Push the **UP** or **DN** buttons to move the **X** to Monitor Contrast and push **ENT**. Note: Pushing the **ESC** button will take you back to the Menu Screen.

Push the UP or DN buttons to Move the **X** to the desired Selection and then push ENT



Once in the Monitor Contrast Screen, push the **UP** or **DN** buttons to increase or decrease the contrast (Default Setting is -3). Once the desired setting is reached, push and hold the **ENT** button for 1 second. This will lock the new monitor contrast setting. When done push the **ESC** button to leave the page. Note: Pushing the **ESC** button will take you back to the Menu Screen.



MONITOR BRIGHTNESS ADJUSTMENT

From the Operator Adjustments Screen, Push the **UP** or **DN** buttons to move the **X** to Monitor Brightness and push **ENT**. Note: Pushing the **ESC** button will take you back to the Menu Screen.

Push the UP or DN buttons to Move tAuto/MaRoad/Field (R/F) ction and then push ENT



Once in the Monitor Brightness Screen, push the **UP** or **DN** buttons to increase or decrease the brightness (Default Setting is 8). Once the desired setting is reached, push and hold the **ENT** button for 1 second. This will lock the new monitor brightness setting. When done push the **ESC** button to leave the page. Note: Pushing the **ESC** button will take you back to the Menu Screen.



ELECTRICAL SETTINGS

LIMIT SWITCHES AND MAXIMUM LEVEL LAMP

The leveling system is equipped with left and right level limit switches that disable the automatic/manual leveling when the combine reaches its maximum leveling capability in either direction. These switches are preset by the installer at either the maximum leveling capability of the combine or in some cases at a lesser angle to provide for proper tire clearance. It is important to note that in the event of a limit switch failure the combine may continue to level to its maximum capability. Care should be taken to make sure tire clearances are adequate in the maximum level position to prevent damage to the tire or chassis in the event that a limit switch failure should occur. The limit switches also actuate the maximum level lamp that indicates to the operator when the combine has reached its maximum leveling capability. The operator should daily level the combine to its maximum level position, with the bulk tank empty, using the manual leveling switch to insure the limit switches and maximum level lamp are operational. The maximum level lamp will only light when the manual switch is held into the left or right leveling position or the system is in the automatic mode when the combine reaches maximum level.

IMPORTANT:



With certain tire selections the limit switches can be used to prevent the need to modify the sheet metal on the left and right side panels of the combine. Installation of level limit stops is recommended to prevent sheet metal damage in the event of a limit switch failure. (See LEVEL LIMIT STOPS on Next Page)

HOW TO SET LIMIT SWITCHES

To set the limit switches, park the combine on level ground and set the parking brake. Then raise the feeder spout and drop the header lift cylinder safety stop. Place the auto/manual-leveling switch in the manual position. Lean the combine to the left until either the maximum leveling capabilities of the leveling system are reached or there is approximately one inch of clearance between the tires and any metal that may interfere with them. Next, shut off the machine. The limit switches are located on each side of the gray controller box near the main pivot pin. Loosen the bolt that holds the left limit switch stop in place. Adjust the left limit switch stop up to the point where you can hear the contacts on the limit switch snap and move slightly past this point. Repeat this process for the right limit switch.



If Level Limit Stops are used be sure that the limit switches are set to stop leveling before the level limit stops make contact. Damage to the cylinders or other leveling system components may occur if limit switches aren't set properly.

LEVEL LIMIT STOPS

On the Model 2810 Leveling System a Level Limiting Spacer Kit can be clamped on the main leveling cylinders to mechanically stop leveling if the limit switches were to fail. To determine how many spacers are needed to create a mechanical stop follow these steps:

1. Park the combine on level ground and apply the parking brake.
2. Raise the feeder spout and drop the header lift cylinder safety stop.
3. Place the auto/manual-leveling switch in the manual position and lean the combine to the left until the limit switch that was set previously stops leveling.
4. Shut off the machine and measure the distance between the packing gland on the rod end of the cylinder and the ring that is welded to the rod end.
5. Write down this dimension and repeat the process for the right side. (Both sides must be measured due to the fact that the combine may level further one direction than the other.)
6. The dimensions obtained will determine how many spacers are needed.

There is no additional charge for the level limit stops (Call Hillco with dimensions to order).



If Level Limit Stops are used be sure that the limit switches are set to stop leveling before the level limit stops make contact. Damage to the cylinders or other leveling system components may occur if limit switches aren't set properly.

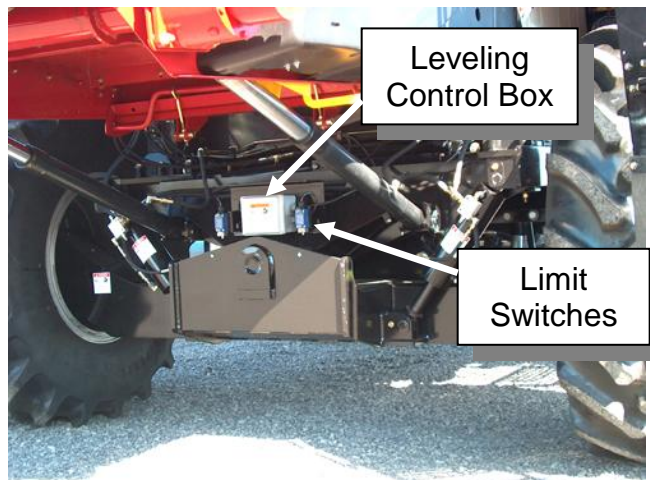

LEVELING CONTROLLER FUNCTION

The Hillco Model 2810 Leveling System is equipped with a proportional leveling system with manual control and automatic with manual override control. The clinometer, located in the control box, monitors changes in slope and corrects the position of the combine's chassis using proportional leveling. The clinometer maintains leveling accuracy to +/- 1/10th degrees by sending the leveling signal to the proportional leveling control valve on the manifold. As the combine reaches higher degrees of being out of level, the clinometer sends more voltage to the directional control valve's coil and pulls the spool open further to allow oil to flow faster and speed up leveling. As the combine gets closer to +/- 1/10th degrees out of level, less voltage is sent to the coil to slow leveling.

MECHANICAL ADJUSTMENTS

MODEL 2810 TREAD WIDTH – Slope Restrictions

The Model 2810 Leveling System is designed around a main undercarriage length of 3120mm (122-13/16”), which is identical to the combine’s original axle tube length with 265mm (10-7/16”) axle extensions. The final drives are mounted directly to the undercarriage and axle extensions are not required. **Dual tires are required on all AFX 8010 combines equipped with the Model 2810 Leveling System. The dual tire and wheel package sold from Hillco creates a 120”-180” tread spacing.**



TIRE SELECTION – Slope Restrictions

Model 2810 Dual Tires – **Combines equipped with the Model 2810 Leveling System must be equipped with the 650/75R32 172A8 R1W dual tire and wheel package supplied by Hillco or the 620/70R42 160A8 R1W supplied by Case IH to safely support the weight of the combine.**



Model 2810 Steering Tires – **Combines equipped with the Model 2810 Leveling System must be equipped with 480/70R30, 540/65R30, or 600/65R28 rear tires for proper rear side panel clearance. The 600/65R28 tire has the highest load carrying capacity and is the tire of choice.**



FEEDER ADJUSTMENT FOR TIRE SIZE

Adjust the feeder adapter to obtain the proper header angle and cutter bar height as shown in the AFX 8010, 8120 or 9120 Operator’s Manual. The chart shown in those manuals will no longer be a correct guide to adjust the feeder adapter due to the height increase created by the leveling system.



Important: When rotating the transition throat to obtain proper header angle, pay special attention to the 60P chain tension. **The 60P chain will have to be lengthened when rotating rearward.**



Do not use the eyebolt to adjust the header angle. The threads will strip.

CONVEYOR DRUM FORE / AFT POSITION

The conveyor drum may need to be repositioned. The position of the conveyor drum should be set fore or aft so that there is approximately a 1-inch distance between feeder chain slat tip and the paddle beater.

HEADER AND COMBINE CONNECTION

Refer to the AFX 8010, 8120 or 9120 Operators Manual for instructions on connecting the header to the combine.

All headers require header kits to function properly on the Model 2810 Leveling System. Contact your dealer for additional information on these kits.

REAR AXLE WEIGHTING

Proper rear axle weighting of a combine equipped with a 2000 Series leveling system is critical to the performance and safety of operation. Rear axle weighting increases the tip angle of the combine to improve down hill maneuvers. The appropriate weighting is dependent on such items as feeder house length, header selection, and tire selection. Consult your authorized 2000 Series dealer for weighting information.

Weight can be added to the rear axle through:

- 1) Calcium Chloride in rear tires
- 2) CNH Rear Axle Weight System
- 3) CNH Rear Wheel Weight System

Use caution when using individual turning brakes. Installation of a Hillco Leveling System transmits additional weight to the rear axle of the combine. Excessive braking to turn can damage your combine chassis.



The responsibility for making the final determination of appropriate rear axle weighting lies with the operator.

When first operating the 2000 Series leveling system in hillside conditions, begin operation on gradual slopes and work up to more severe slopes only after you have determined that rear axle weighting is appropriate for downhill maneuvers. The first indication of insufficient rear axle weighting is sluggish or unresponsive steering while traveling down hill. This effect will worsen if the operator decelerates. Make sure rear axle weighting is sufficient for safe down hill maneuvers, under normal deceleration, in your most severe down hill conditions.



Use of grain tank extensions other than those provided by the Combine manufacturer is strictly forbidden. Use of such Extensions voids both the Hillco and Case IH NEW Equipment Warranties.

REAR AXLE TOE IN

If the rear tire and wheel size changed after the proper sized rear tires were installed the toe in should be checked. Consult your combine's operator's manual on the correct toe in for your tire and wheel size.

FEEDER CONVEYOR SLIP CLUTCH

The feeder conveyor slip clutch should be adjusted yearly to make sure it will protect all of the feeder drive components. Consult your combine's operator's manual on the correct procedure for adjusting the slip clutch.

TRANSITION DRIVE CHAIN

Check to see that the transition drive chain is in proper alignment and has proper tension. Misalignment of these sprockets will cause premature wear of the sprockets and chain. Chain tension is maintained on the 60-pitch chain with an idler sprocket and on the 80-pitch chain by moving the jackshaft assembly. Both are located on the right side of the transition.

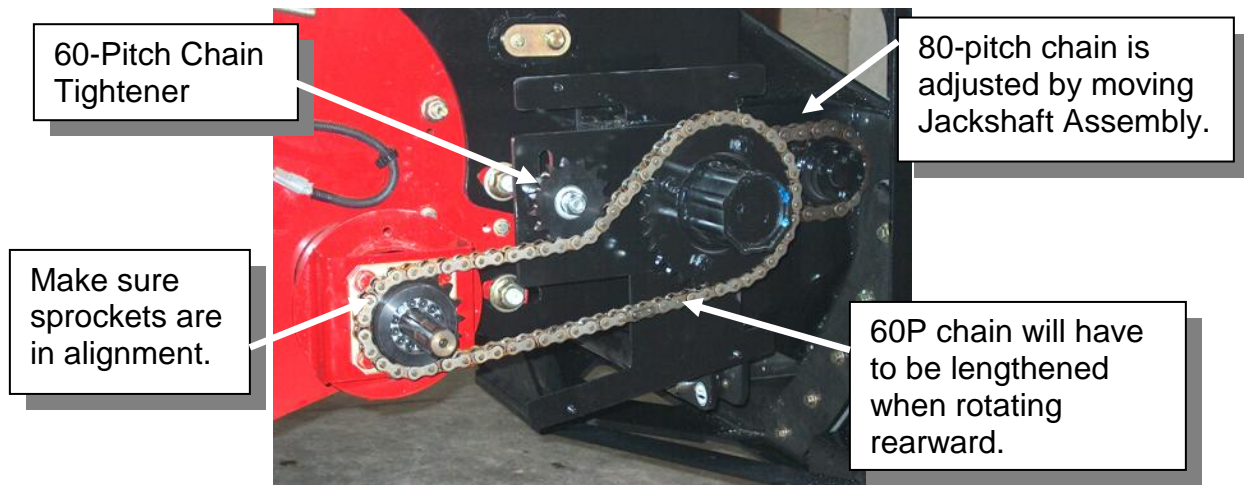

Do not over tighten idler sprockets or premature chain and sprocket wear will occur.

TRANSITION SLIP CLUTCH

The transition slip clutch is preset at the factory so that damage will not occur to any of the transition drive components; it cannot be adjusted and will never require any adjustment. See page 23 for lubrication information.

SHAFT STRIPPERS & NARROWING PLATES

The purpose of the Shaft Stripper is to strip viney material from the paddle and prevent it from wrapping around the end of the paddle beater shaft causing premature bearing failure. The Narrowing Plate forces the material in towards the center of the paddles to help prevent material from wrapping.

The Narrowing Plates are NOT REQUIRED. They are OPTIONAL and intended for use in viney crops. They can be added or removed at the Operator's Discretion.

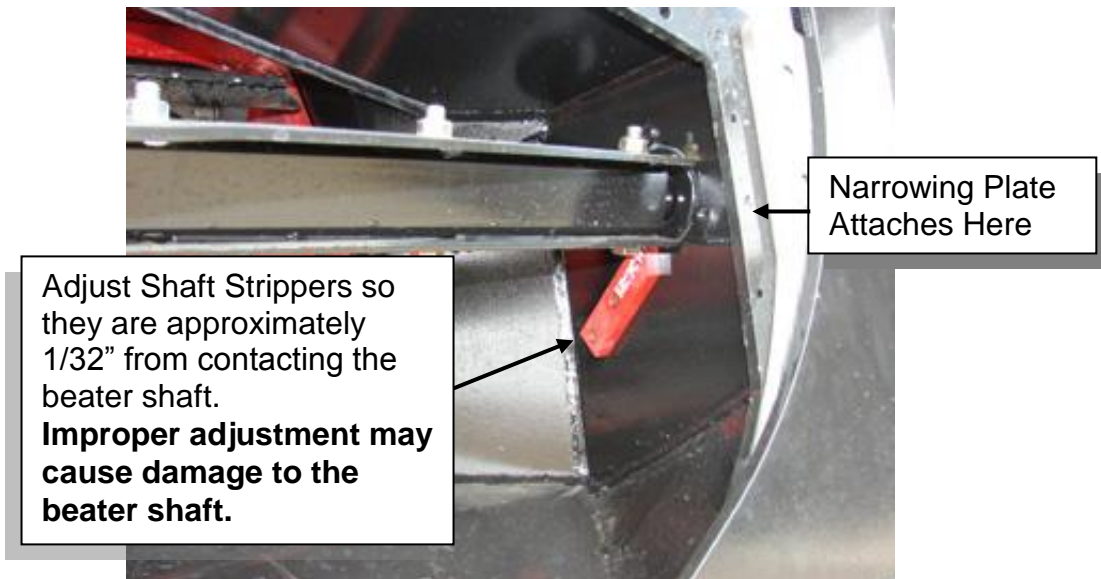

Rotate the Beater Shaft One Full Revolution after adjusting Shaft Strippers to be sure they don't contact shaft. Adjust Shaft Strippers so they are 1/32 inch from contacting beater shaft. Improper adjustment may cause damage to the beater shaft.

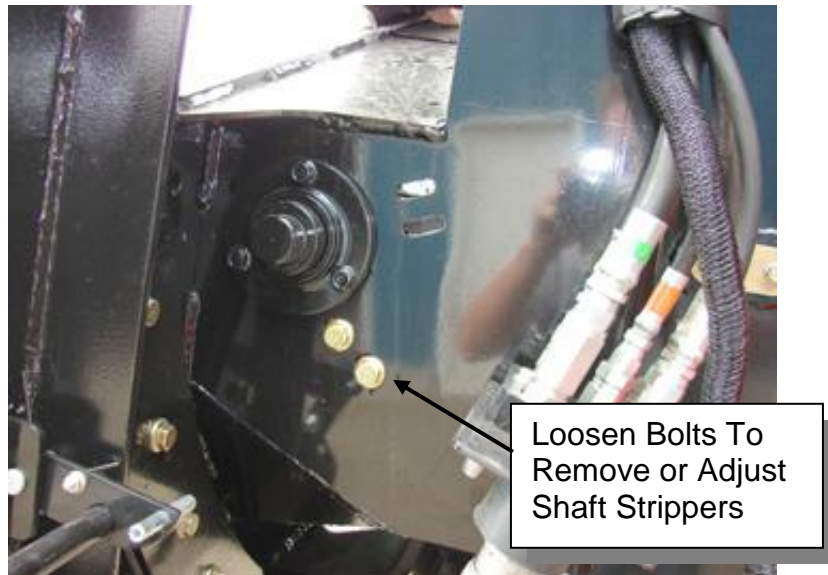

LADDER

If the ladder doesn't extend and retract properly check the fasteners in all of the pivot locations and make sure they aren't over tightened. Over tightening of these fasteners will cause the ladder to bind.

Make sure that the gas-charged struts keep the ladder fully retracted. Replace the struts if they appear to be weak. **If the ladder doesn't fully retract permanent damage may occur during field operation.**

LEVELING CYLINDER SAFETY STOPS

When the leveling cylinder safety stops are installed on the leveling cylinders, the carriage cannot rotate. The stops must be installed before working on or around the leveling system and also when hauling the combine. It is recommended that the stops be used during long term storage. When the stops are not being used, they should be stored on the mount next to the leveling cylinder.

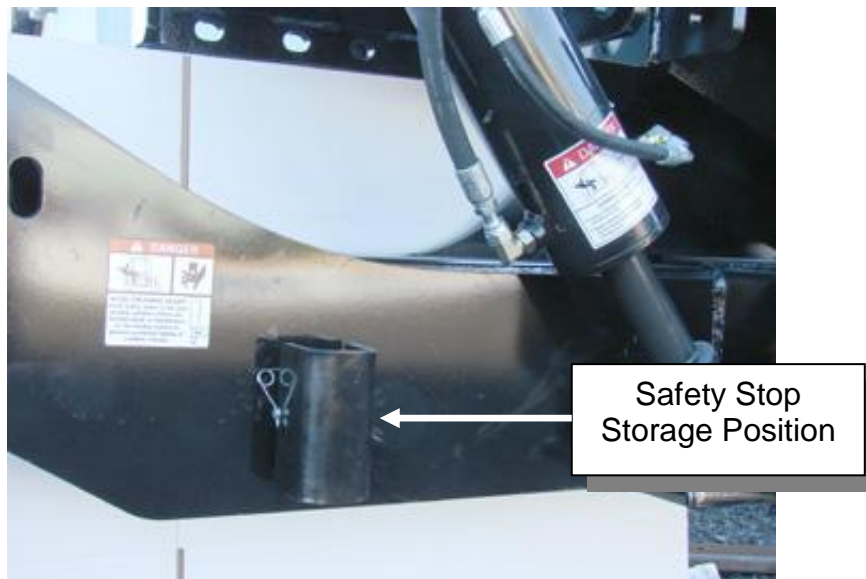

GENERAL SHIELDING

Before operating the combine all shields must be in place and in working condition.

Shield to tire clearance needs to be checked once the correct tires are installed on the combine. Check to see if the clearance is correct by having someone watch the tire and shields as the operator leans the combine to the far right and far left. Some tire selections require limit switches to be set slightly early to allow enough tire clearance between the left and right front side panels.

HYDRAULIC SETTINGS

Refer to the Hydraulic Safety section located on page 6 for precautions regarding the hydraulic system.

The Model 2810 Leveling System utilizes the existing auxiliary combine hydraulic system for their hydraulic requirements with the exception of the addition of a stand-alone leveling manifold located behind the left shield to the rear of the operator's platform. The hydraulic schematic located in the rear of this manual covers the leveling system circuitry. Consult your combine's operator's manual or contact your Case-IH dealer for diagnostics and maintenance regarding the remainder of the hydraulic system.

IMPORTANT:

All adjustments on the hydraulic system are preset at the factory for optimal leveling and header trim performance. DO NOT MAKE ANY ADJUSTMENTS TO THESE SETTINGS WITHOUT FIRST CONTACTING YOUR AUTHORIZED HILLCO DEALER.

PRESSURE COMPENSATOR SETTING (36' Draper Headers Only)

The pressure compensator setting must be adjusted to 3200-3300psi to maintain proper header lift speed when using 36' Draper headers unless combine is equipped with 90mm left cylinders. Refer to the AFX 8010, 8120 or 9120 Repair Manual for pressure compensator location and adjustment procedure.

HYDRAULIC HOSES

Inspect hydraulic system for leaks, damaged hoses, improper routing, and loose fittings.

Hydraulic hoses that are not routed correctly could become worn from working against abrasive edges or moving parts. If abrasions or holes do occur, the hydraulic hoses can only be repaired by replacement. **Do not attempt repairs with tape or cements.** High pressure will burst such repairs and cause system failure and possible injury.

Hydraulic Hose Connections – When tightening loose hoses on the cylinders, pump, etc., always use one wrench to keep the hose from twisting and another wrench to tighten the union. Excessive twisting will shorten hose life and allow the fitting to loosen during operation. Do not over-tighten fittings or adapters.

Refer to the AFX 8010, 8120 or 9120 Operator's Manual for information regarding hydraulic oil check intervals, and reservoir fluid levels. Leveling and header trim speeds are preset at the factory. If different speeds are desired please contact your Hillco dealer.

HYDRAULIC CYLINDERS**IMPORTANT:**

Each leveling cylinder is equipped with a safety valve (counterbalance valve) that is in place to prevent unintentional leak down of the cylinder. These safety valves are preset at the factory, and should not be adjusted.



DANGER: Do not make any repairs to the cylinders, disconnect valves, or disconnect any hoses connected to the cylinders, counterbalance valves, bulkhead mount or manifold without first contacting your authorized Hillco dealer. These hydraulic components stabilize the chassis of the combine. Improper repair or replacement of these components could lead to uncontrolled leveling of the combine's chassis. The leveling cylinder safety stops can be used to prevent accidental tipping of the combine during repair.

GREASE LOCATIONS

Use Case-IH 251H EP or equivalent NLGI #2 Multi-Purpose Lithium Grease.

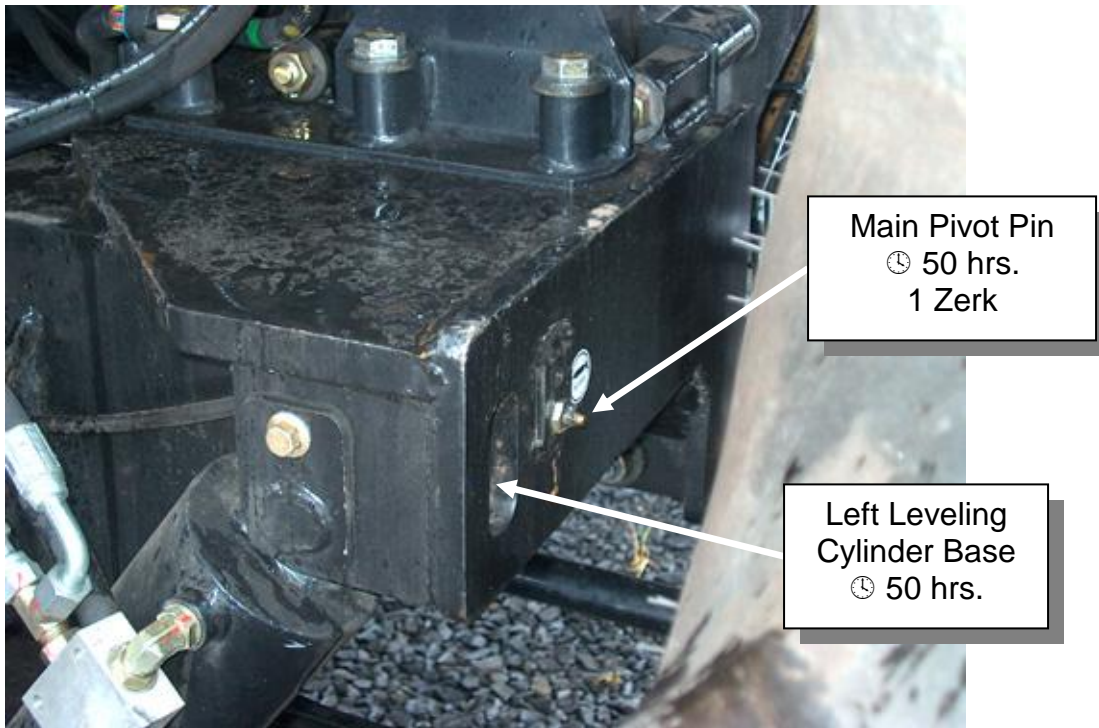

GREASE LOCATIONS

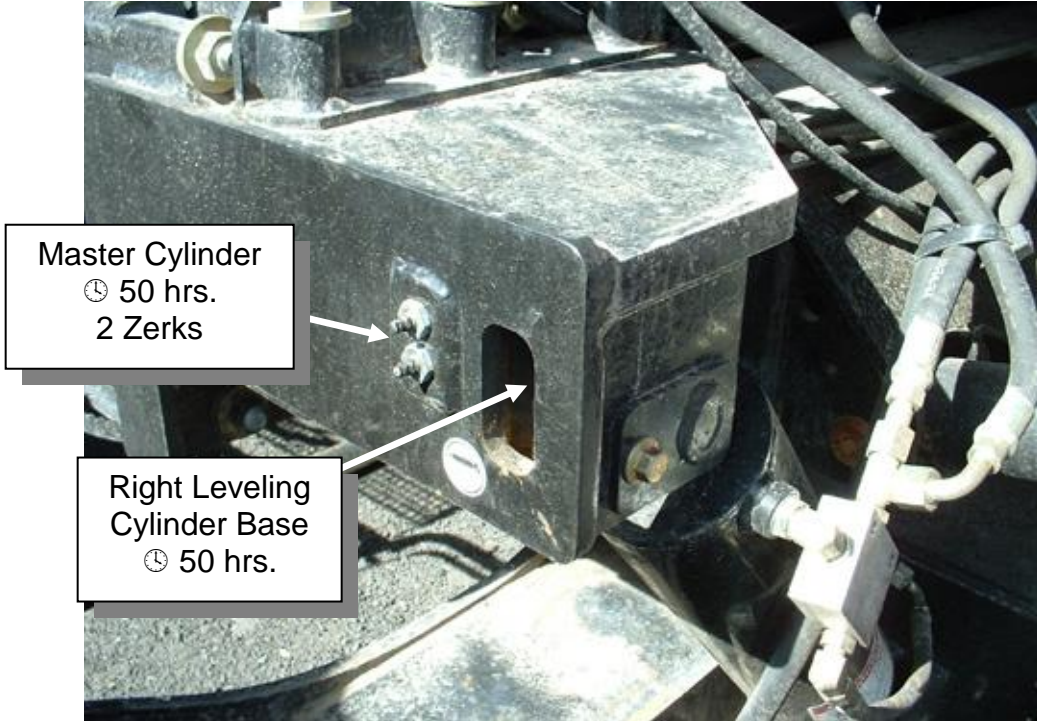

GREASE LOCATIONS

Transition Slip Clutch
⌚ 50 hrs. Little To No Slippage
Grease Daily in Adverse Feeding
Conditions where slippage may
occur more often.
Pump until grease comes out.



Left and Right
Leveling Cylinders
Rod End
⌚ 50 hrs



FASTENERS

Check Bolt Tightness

- After the first 10 hours of operation
- Every season

The following bolts are torqued to special specifications because of the application in which they are used:

Transmission Mounting Bolts: Case IH® torque specifications
(Medium Strength Loctite is Used on These Bolts, Check for Looseness ONLY)

Final Drive Housing Bolts: Case IH® torque specifications
(Medium Strength Loctite is Used on These Bolts, Check for Looseness ONLY)

Drive Wheel Hub Bolts: Case IH® torque specifications

Steering Wheel Hub Bolts: Case IH® torque specifications

IMPORTANT: Consult your Case IH® AFX 8010, 8120 or 9120 Operator's Manual to verify that correct bolts and spacers are used for the Rear Wheel Application.

The following two pages shows torque charts for metric and standard fasteners. Use these charts for checking torques on bolts not shown above.

METRIC TORQUE CHART

SI Bolt and Cap Screw Torque Values (For Hillco Leveling Systems Only)

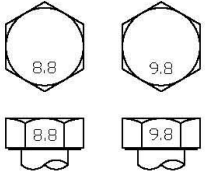
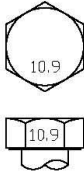
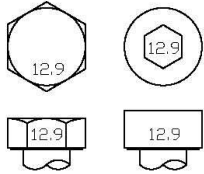
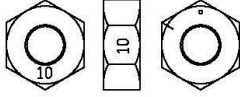
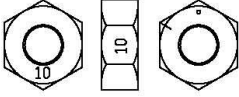
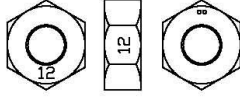
<p>Property Class and Head Markings</p>			
<p>Property Class and Nut Markings</p>			







SIZE	Class 8.8 or 9.8				Class 10.9				Class 12.9			
	Lubricated(1)		Dry(2)		Lubricated(1)		Dry(2)		Lubricated(1)		Dry(2)	
	N*m	lb-ft	N*m	lb-ft	N*m	lb-ft	N*m	lb-ft	N*m	lb-ft	N*m	lb-ft
M6	9	6.5	11	8.5	13	9.5	17	12	15	11.5	19	14.5
M8	22	16	28	20	32	24	40	30	37	28	47	35
M10	43	32	55	40	63	47	80	60	75	55	95	70
M12	75	55	95	70	110	80	140	105	130	95	165	120
M14	120	88	150	110	175	130	225	165	205	150	260	190
M16	190	140	240	175	275	200	350	255	320	240	400	300
M18	260	195	330	250	375	275	475	350	440	325	560	410
M20	375	275	475	350	530	400	675	500	625	460	800	580
M22	510	375	650	475	725	540	925	675	850	625	1075	800
M24	650	475	825	600	925	675	1150	850	1075	800	1350	1000
M27	950	700	1200	875	1350	1000	1700	1250	1600	1150	2000	1500
M30	1300	950	1650	1200	1850	1350	2300	1700	2150	1600	2700	2000
M33	1750	1300	2200	1650	2500	1850	3150	2350	2900	2150	3700	2750
M36	2250	1650	2850	2100	3200	2350	4050	3000	3750	2750	4750	3500

(1) "Lubricated" Means coated with a lubricant such as engine oil, or fasteners with phosphate and oil coatings.

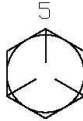
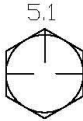
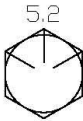
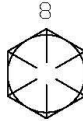
(2) "Dry" means plain or zinc plated without any lubrication.

STANDARD TORQUE CHART

Unified Inch Bolt and Cap Screw Torque Values (For Hillco Leveling Systems Only)

SAE Grade and Head Markings	  	 
SAE Grade and Nut Markings	 	 

SIZE	Grade 5, 5.1, or 5.2				Grade 8 or 8.2			
	Lubricated(1)		Dry(2)		Lubricated(1)		Dry(2)	
	N*m	lb-ft	N*m	lb-ft	N*m	lb-ft	N*m	lb-ft
1/4	9.5	7	12	9	13.5	10	17	12.5
5/16	20	15	25	18	28	21	35	26
3/8	35	26	44	33	50	36	63	46
7/16	55	41	70	52	80	58	100	75
1/2	85	63	110	80	120	90	150	115
9/16	125	90	155	115	175	130	225	160
5/8	170	125	215	160	240	175	300	225
3/4	300	225	375	280	425	310	550	400
7/8	490	360	625	450	700	500	875	650
1	725	540	925	675	1050	750	1300	975
1-1/8	900	675	1150	850	1450	1075	1850	1350
1-1/4	1300	950	1650	1200	2050	1500	2600	1950
1-3/8	1750	1250	2150	1550	2700	2000	3400	2550
1-1/2	2250	1650	2850	2100	3600	2650	4550	3350

(1) "Lubricated" Means coated with a lubricant such as engine oil, or fasteners with phosphate and oil coatings.

(2) "Dry" means plain or zinc plated without any lubrication.

TIRE INFLATION

Keep the tires properly inflated to the pressures shown in the combine's operator's manual for the front and rear tires. Both under-inflation and over-inflation are detrimental to tire life. Don't re-inflate a tire that has been run flat or when there is obvious or suspected damage to the tire or wheel components. Check the tire pressure weekly or after 50 hours of operation.



WARNING: *When inflating tires, use a clip on air chuck and extension hose long enough to allow you to stand to one side and NOT in front or over the tire assembly. Use a safety cage if available.*



WARNING: *A tire can explode during inflation and cause serious injury or death. Never increase air pressure beyond 35 PSI to seat the bead on the rim. Replace a tire if it has a defect. Replace a wheel rim, which has cracks, wear or severe rust. Make sure that all the air is removed from a tire before removing the tire from the rim. Never use force on an inflated or partially inflated tire. Make sure the tire is correctly seated before inflating.*

SCHEMATICS

2810 ELECTRICAL CIRCUIT SCHEMATIC

Model 2810H Leveling Electrical Circuit Schematic

FOR ALL 8010, 8120 & 9120 Case-IH Combines
HILLCO S/N 14001 Thru 14999

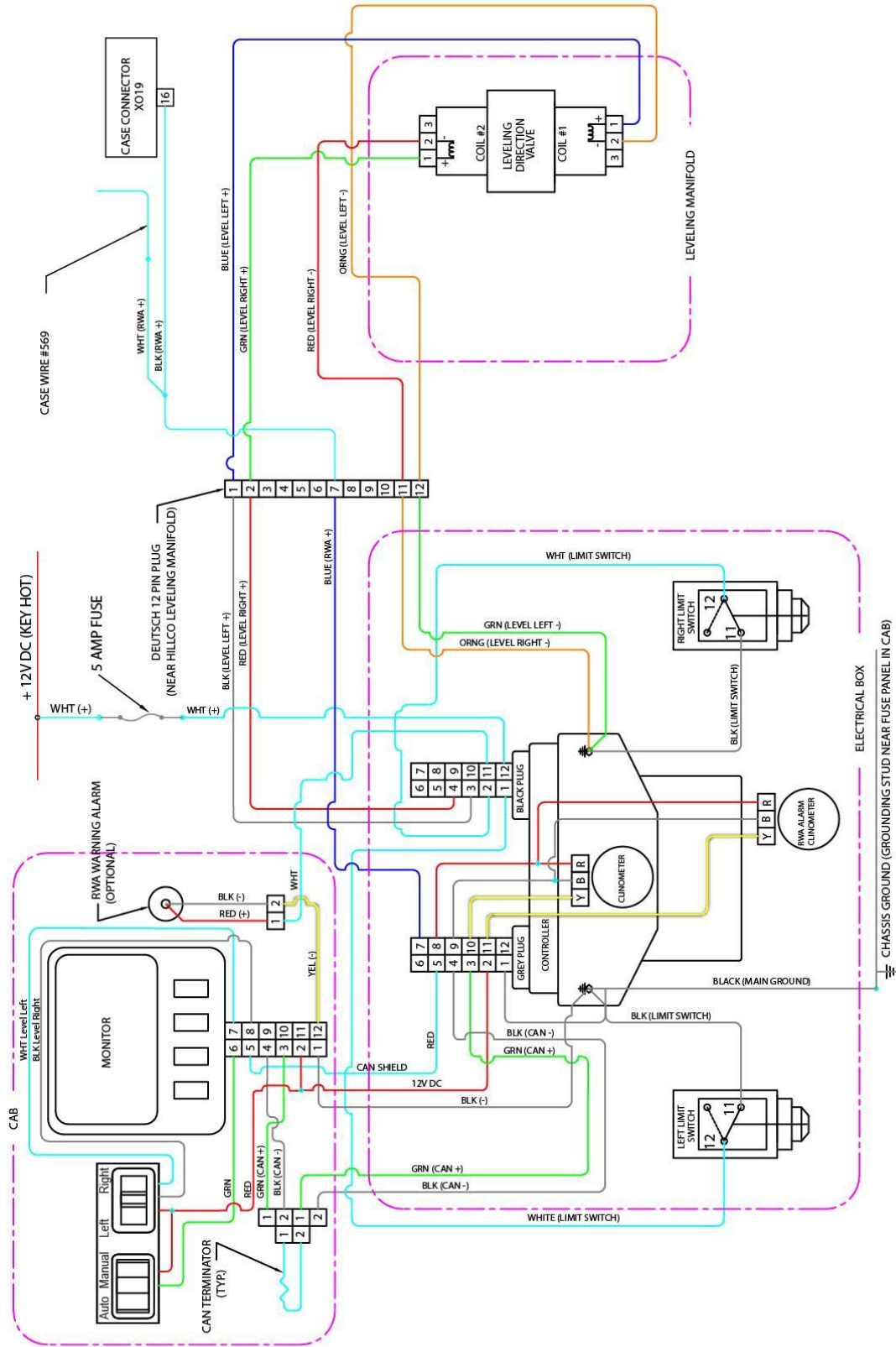

2810

Model 2810H Leveling Hydraulic Schematic

FOR ALL 8010, 8120 & 9120 Case-IH Combines

HILLCO S/N 14001 Thru 14999

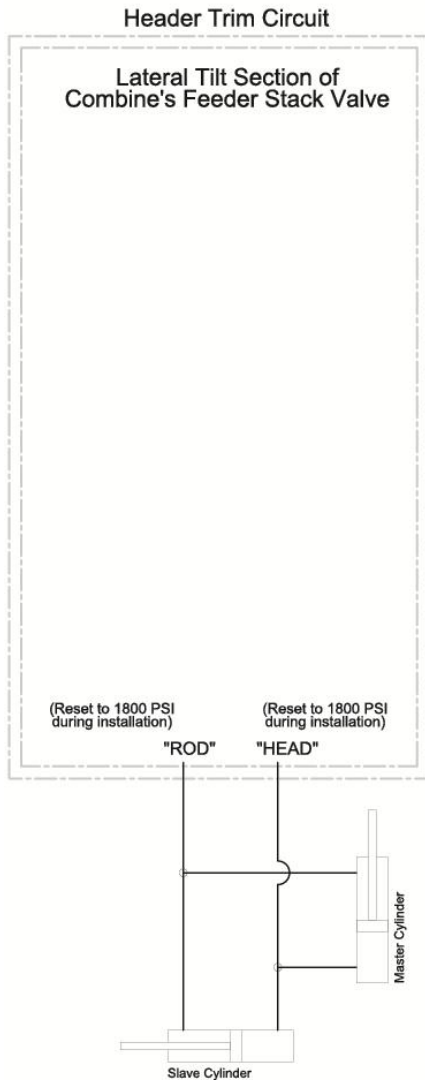

HYDRAULIC CIRCUIT SCHEMATIC

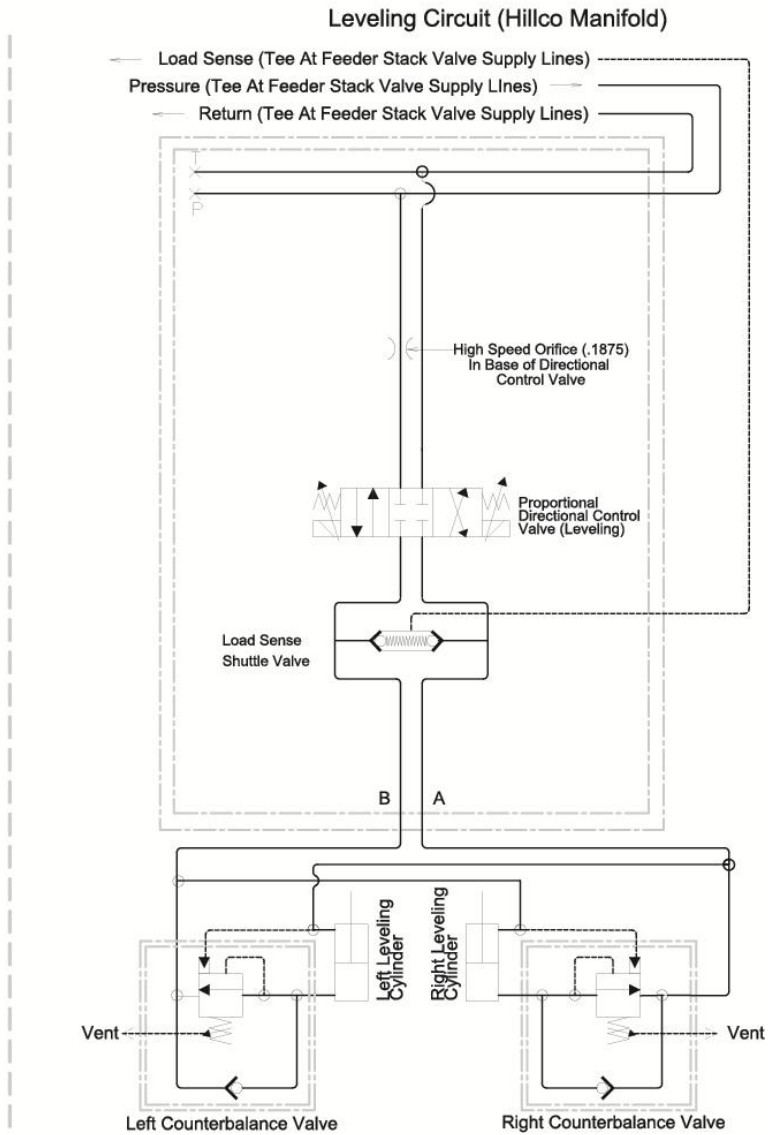

Notes