

Model JS9010 Hillco Leveling System  
For Serial Numbers JS9010-13001 thru JS9010-13999



# **Model JS9010 Sidehill Leveling System Parts Manual**

SN JS9010-13001 thru JS9010-13999

For John Deere S680 & S690  
S Series Combines

D-120618CMA01A



# JS9010 Hillside Leveling System

For S680 & S690 S Series Combines

## Table of Contents

<b>General Information</b>	<b>3</b>
Serial Number Location	3
Text and Illustrations	3
Abbreviations	3
Right and left Identification	3
Part Orders	3
<b>Transition</b>	<b>4</b>
Tilt Sensor	5
Transition Throat	6
Transition Header Adapter	8
<b>Carriage</b>	<b>10</b>
Overcarriage	11
Undercarriage	13
Carriage Misc. Parts	14
Carriage Position Sensor	15
<b>Drop Axle</b>	<b>17</b>
<b>Hydraulic Components</b>	<b>18</b>
Hydro Hose Adapters	18
Leveling Manifold	19
John Deere Header Lift Manifold	20
ProDrive Transmission Hydraulic Hoses	21
<b>Retractable Ladder</b>	<b>22</b>
<b>Ladder Wedge</b>	<b>24</b>
<b>Electrical</b>	<b>26</b>
Controller/Wiring Harnesses	26
<b>Decals and Literature</b>	<b>27</b>

### Contact Information

Hillco Technologies, Inc.  
107 1st Avenue  
Nezperce, Idaho 83543

Phone	800-937-2461
	208-937-2461
Fax	208-937-2280

[www.hillcotechnologies.com](http://www.hillcotechnologies.com)  
email: [support@hillcotechnologies.com](mailto:support@hillcotechnologies.com)

## **GENERAL INFORMATION**

### **SERIAL NUMBER LOCATION**

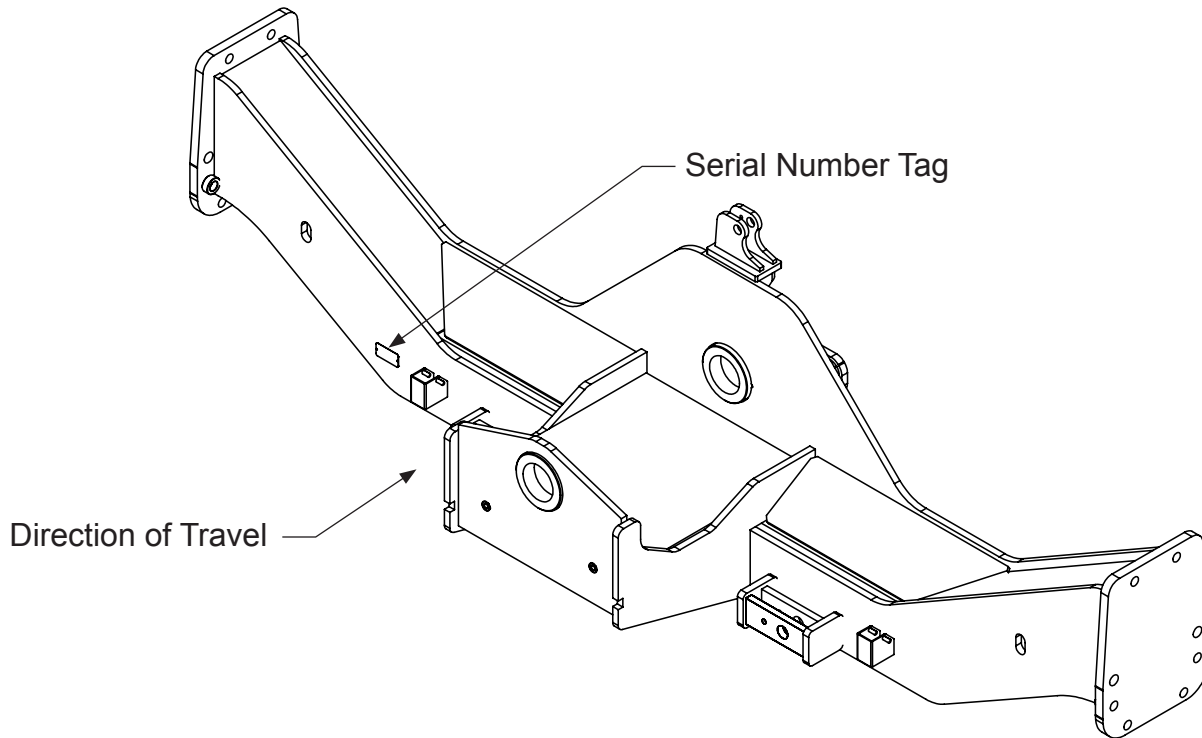

### **TEXT AND ILLUSTRATIONS**

The arrangement of this parts catalog is for easy identification of parts. All parts are illustrated in exploded views in proper relation to each other. Some diagrams refer to other pages for further information. Reference numbers used in the illustrations refer to line numbers in the part lists. The part lists appear to the right or below all diagrams and correspond with those diagrams. Included in the part lists, along with the reference numbers are part numbers, part descriptions and the quantity of the part required per leveling system.

### **ABBREVIATIONS**

**SN** "Serial Number" refers to the serial number given to each leveling system (by Hillco Technologies), as well as the serial number given to the combine (by the specific combine manufacturer) the leveling system is installed. See above for the leveling system's serial number location. This abbreviation is used interchangeably in both instances. Each Model JS9010 Leveling System uses the following serial number format: JS9010-XXXXX (sequential numbers).

**ASM** "Assembly" refers to a whole grouping of parts (shown in the diagram corresponding with the page where "ASM" is shown unless otherwise noted). Some assemblies have parts that are sold separately, however some must be purchased as a single unit. Hillco Product Specialists will be able to assist you with any questions.

**NS** "Not Shown" refers to a part that is not depicted in the illustration.

### **RIGHT AND LEFT IDENTIFICATION**

The reference to right-hand and left-hand in this catalog is identified by the operator sitting in the operator's seat, looking toward the front of the machine (in normal forward travel).

### **PART ORDERS**

Orders must specify product model, serial number, correct part number, complete description, quantity required, method of shipment, shipping address, and billing address.

Model JS9010 Hillco Leveling System  
For Serial Numbers JS9010-13001 thru JS9010-13999

**TRANSITION**

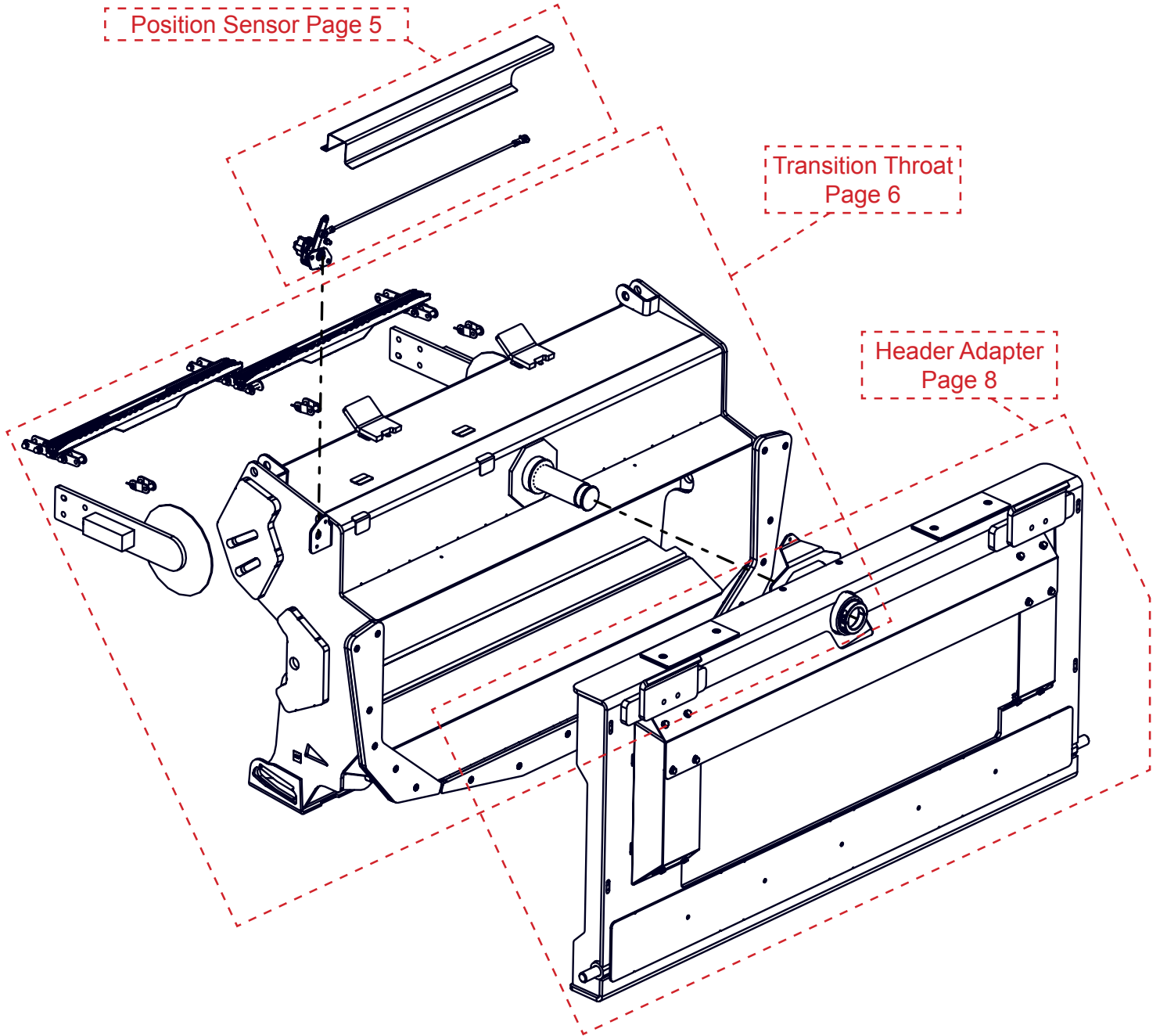

Model JS9010 Hillco Leveling System  
 For Serial Numbers JS9010-13001 thru JS9010-13999

**TRANSITION TILT SENSOR**

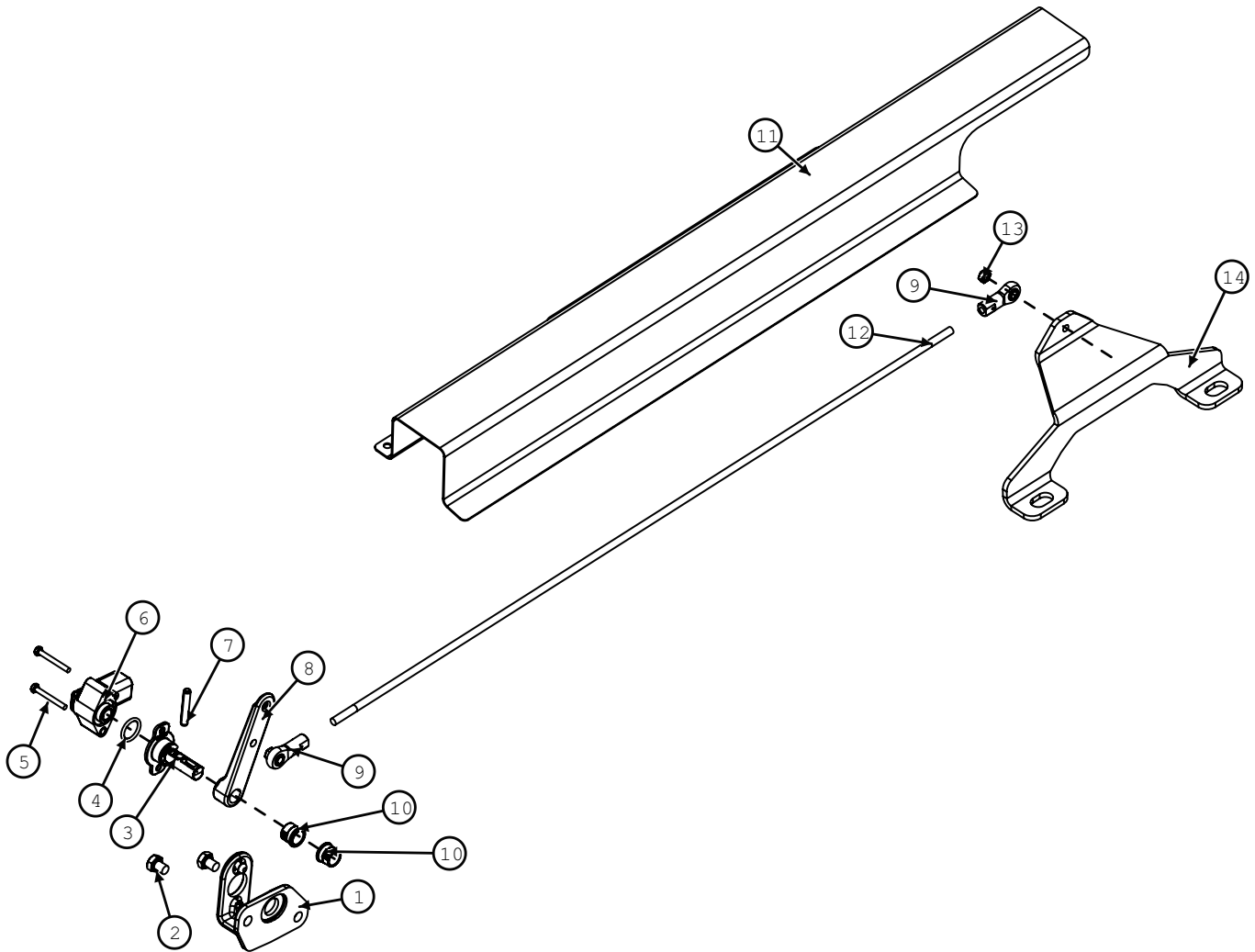

Transition Header Sensor			
BOM ID	Part No.	Qty	Description
1	MC-151321	1	BRACKET, SENSOR MNT (HXE16001)
2	F-HC-08M010F	2	HC-8.8M8X1.25X10 (19m7008)
3	MC-151401	1	SHAFT, ROUGH SERVICE DEVICE (AXE14888)
4	MC-151391	1	O-RING, 11/16ID (P48347)
5	F-HC-04M035E	2	HC-8.8M4X0.7X035 (19m9368)
6	EC-151381	1	SENSOR, ROTATION, HALL 2CH +/-120DE (axe14246)
7	F-PR-06Mx36	1	PIN, ROLL 6mm x 36mm
8	MC-151371	1	LM ARM, TA SENSOR
9	MC-151881	2	ROD END, BALL JOINT, FEMALE, 1/4-28
10	MC-151361	2	BUSHING, (R41076)
11	LB-295541	1	TA SHIELD, SENSOR LINKAGE
12	LS-295502	1	TM ROD, SENSOR LINK
13	F-HNN-06MF	2	HN-8.8M6X1.0 NYLOCK
14	LB-295522	1	TA MNT, SENSOR LINK
9, 12, 13	LA-295572	1	SENSOR LINK ASSEMBLY

Model JS9010 Hillco Leveling System  
For Serial Numbers JS9010-13001 thru JS9010-13999

**TRANSITION THROAT**

**Front**

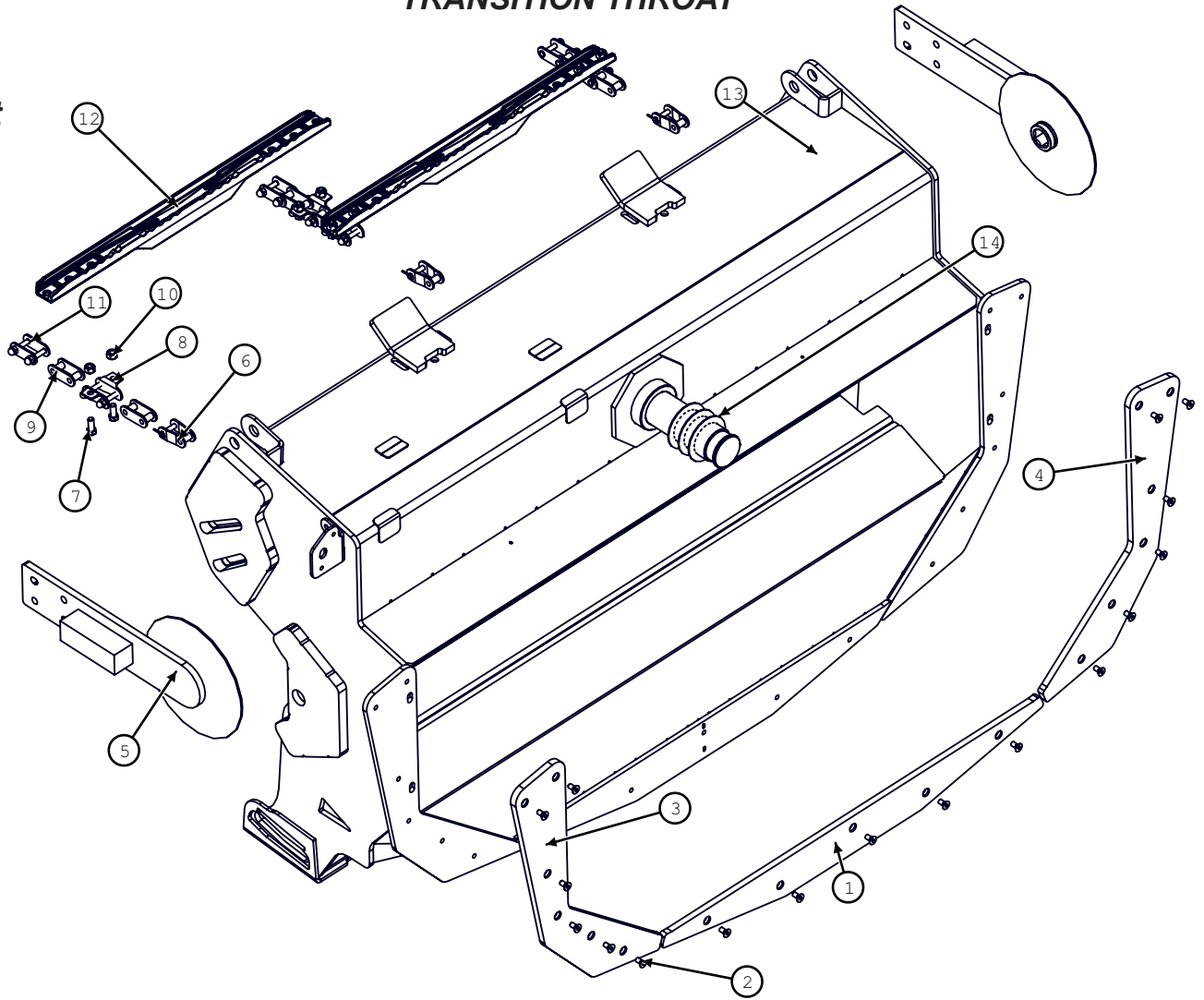

**Back**

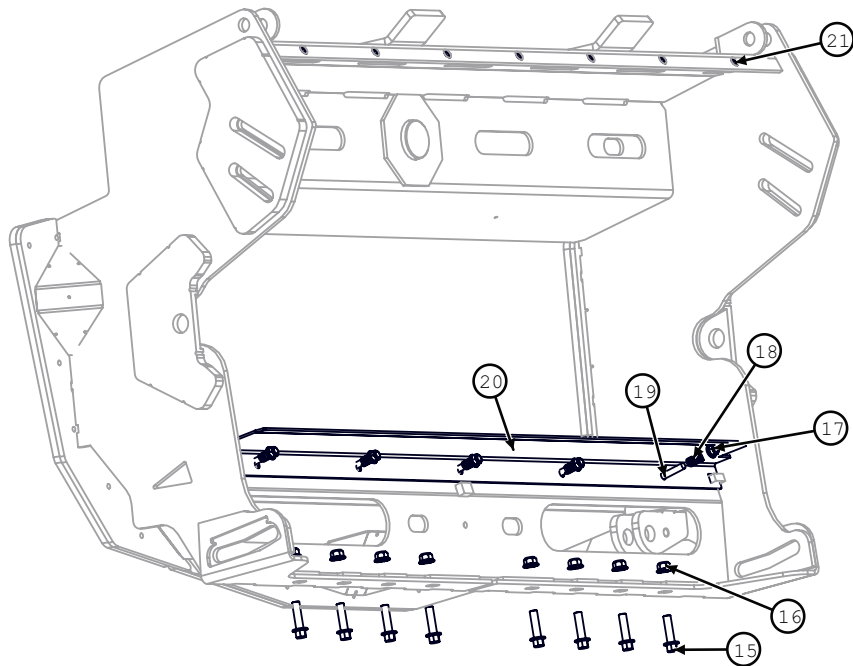

Model JS9010 Hillco Leveling System  
For Serial Numbers JS9010-13001 thru JS9010-13999

<b>Transition Throat</b>			
<b>BOM ID</b>	<b>Part No.</b>	<b>Qty</b>	<b>Description</b>
1	LM-250581	1	TM UHMW, BOTTOM WEARPAD
2	F-FHS-8M016E	17	FHSC-10.9M8X1.25X016
3	LM-250571	1	TM UHMW, RIGHT WEARPAD
4	LM-250561	1	TM UHMW, LEFT WEARPAD
5	LA-269141	2	LM ASM, FDR DRUM ARM (70SERIES 730101-)
6	MC-146641	3	LINK, OFFSET COUPLER CA557 (AH220867)
7	F-HC-10M020E	8	FLHC-M10X1.5X20
8	MC-146381	4	LINK-W/K6, CA557 (AH220868)
9	MC-146391	5	LINK, FEMALE, CA557 (AH209911)
10	F-HNS-10ME	8	HEX NUT-10.9 M10 X 1.50 STOVER PLT
11	MC-140261	3	CHAIN LINK COUPLER, CA557 (JD#AH220541)
12	MC-146402	2	SLAT, CAST (H229581)
13	LW-290461	1	TT ASM, FRONT
14	F-MB-14NR40	3	MACHINE BUSHING 14GAUGE 2-1/2"
15	F-HCF-12M045E	8	FLHC-10.9M12X1.75X45
16	F-HNFS-12ME	8	HEX FLANGE NUT 10.9M12
17	F-HNFS-10ME	5	FLHN-10.9M10X1.5 STVR
18	MC-143591	5	SPRING, C .703DX1.09LX.125W
19	F-CB-10M060F	5	CARR-8.8M10X1.5X60
20	LB-290671	1	TT SHT, FLEX FLOOR
21	F-HNF-08ME	7	FLHN-10.9M8X1.25

### TRANSITION HEADER ADAPTER

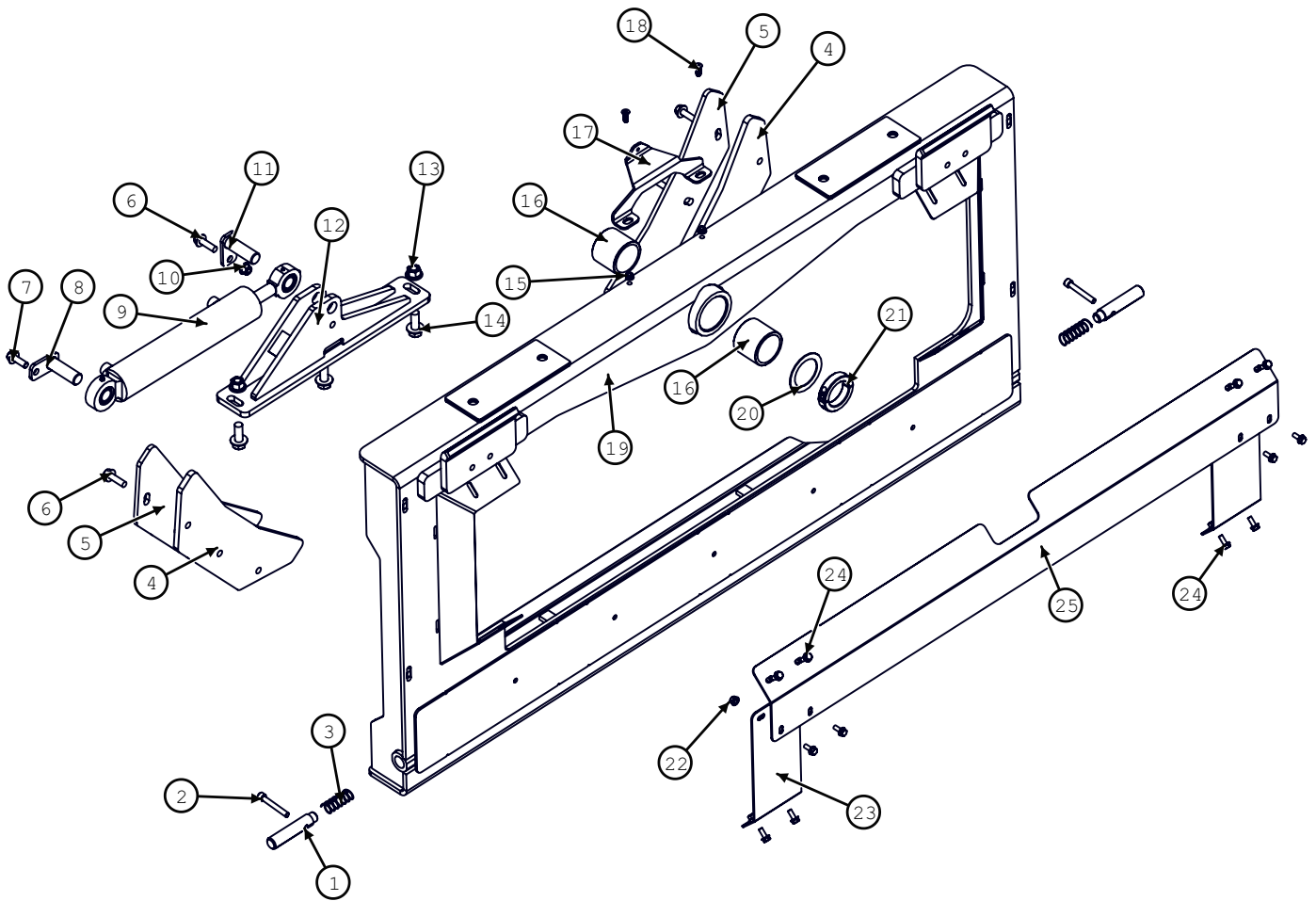



Model JS9010 Hillco Leveling System  
For Serial Numbers JS9010-13001 thru JS9010-13999

<b>Transition Header Adapter</b>			
<b>BOM ID</b>	<b>Part No.</b>	<b>Qty</b>	<b>Description</b>
1	LM-229193	2	TA RND, LOCKOUT PIN
2	F-SHC-10M070F	2	SHCS-8.8 M10 X 1.50 X 70 PLT
3	MC-135531	2	SPRING, COM, 1"ODx2-7/8"Lx .0625W
4	LP-250551	2	TM UHMW, BACKING WEARPAD
5	LP-250541	2	TM PLT, BACKING
6	F-HCF-12M040E	7	FLHN-10.9 M12X1.75X040
7	F-HCF-12M025E	1	FLHC-10.9 M12 X 1.75 X 25
8	LA-253883	1	LM ASM, PIN
9	HC-138582	1	CLY 2-1/2X10, INLINE PORTS
10	F-HNSF-12ME	1	FLHN 10.9 M12 X 1.75 STOVER
11	LA-253883	1	LM ASM, PIN
12	LA-250713	1	TM WLD, SLAVE CYL ROD MNT
13	F-HNSF-16ME	2	FLHN-10.9M16X2.00 STV
14	F-HCF-16M040E	3	FLHC-10.9 M16X2.00X040
15	F-HNF-08ME	2	FLHN-10.9M8X1.25
16	LTP-241721	2	LTM BUSHING, PVT
17	LB-295522	1	TA MNT, SENSOR LINK
18	F-FHS-8M025E	2	FHSC-10.9 M8 X 1.25 X 25
19	LW-250165	1	TA ASM
20	F-MB-14NR40	1	MACHINE BUSHING 14GAUGE 2-1/2"
21	MC-150742	1	COLLAR,CLAMPING,2-1/2 ID 3-3/4 OD, 2 PIECE HEAVY
22	F-HNFS-08ME	12	FLHN-10.9M08X1.25 STOVER
23	LP-250534	2	TM PLATE, L&R SHIELD
24	F-HCF-08M020E	12	FLHC-10.9M8X1.25X20
25	LP-250522	1	TM PLATE, TOP SHIELD

Model JS9010 Hillco Leveling System  
For Serial Numbers JS9010-13001 thru JS9010-13999

**Carriage**

Overcarriage  
Page 11

Carriage  
Position Sensor  
Page 15

Misc.  
Carriage  
Parts  
Page 14

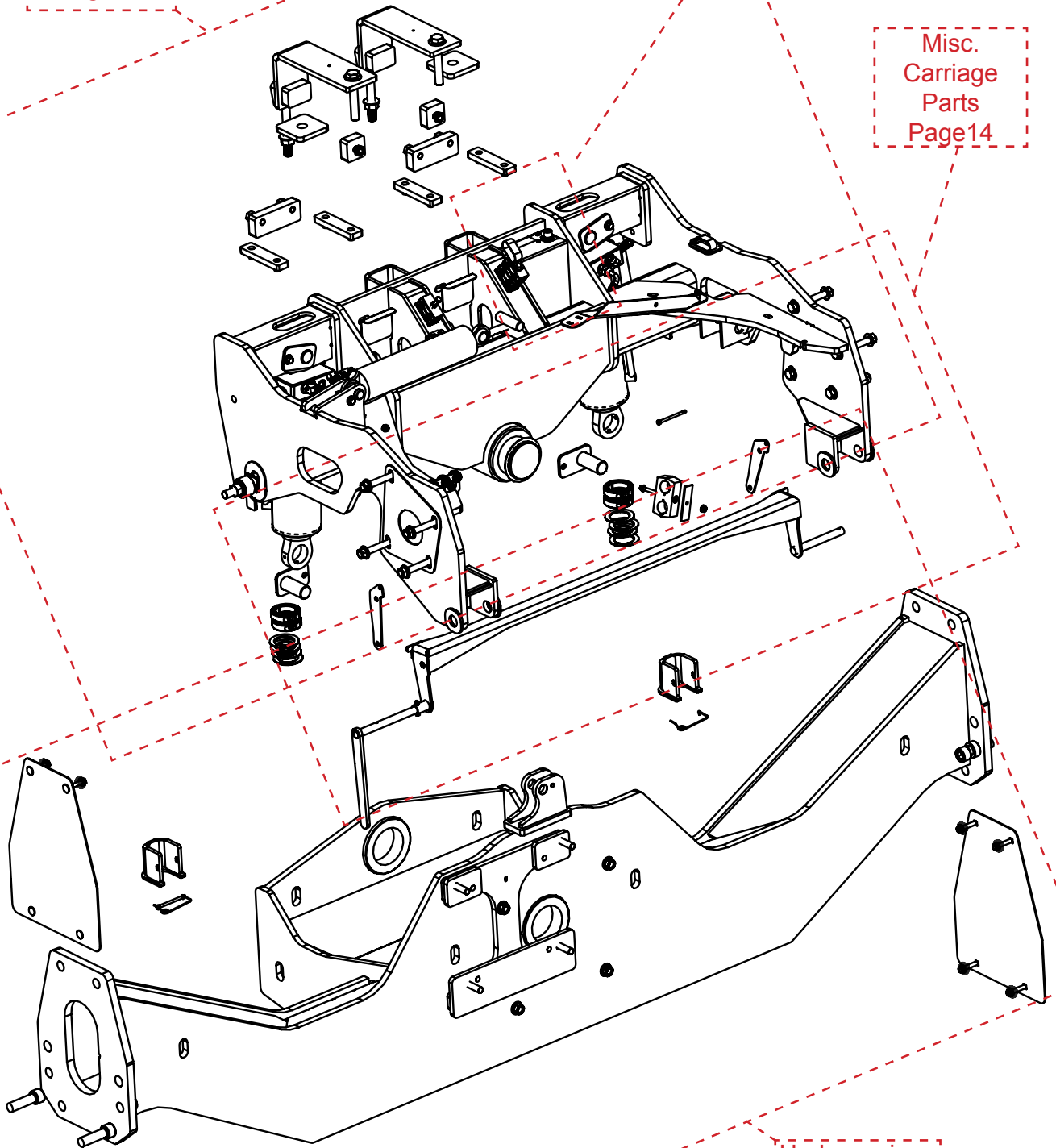

Undercarriage  
Page 13

Model JS9010 Hillco Leveling System  
For Serial Numbers JS9010-13001 thru JS9010-13999

### Overcarriage

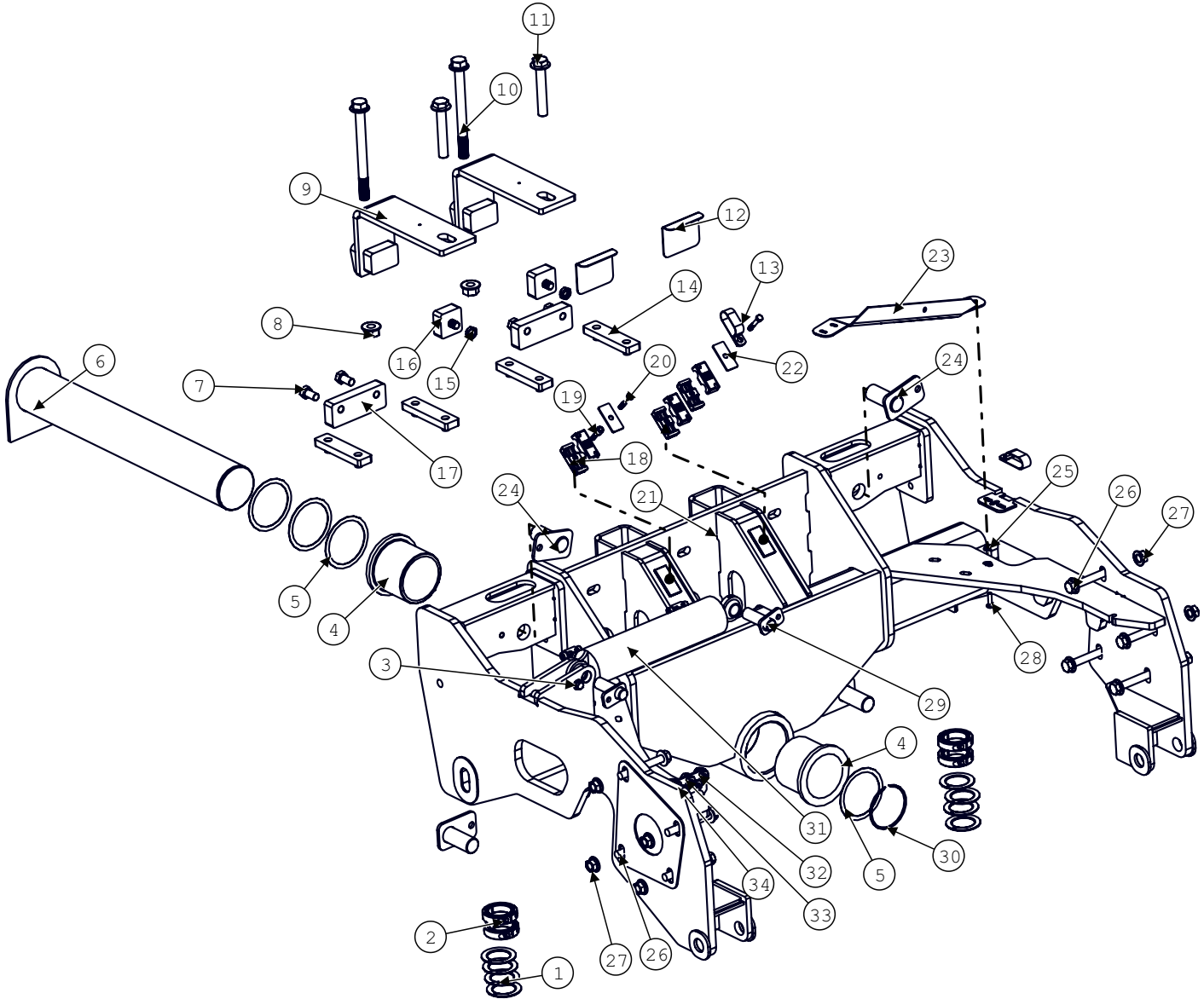

Model JS9010 Hillco Leveling System  
For Serial Numbers JS9010-13001 thru JS9010-13999

Overcarriage			
BOM ID	Part No.	Qty	Description
1	MC-137501	8	WASHER, QUICK REPAIR 2"
2	MC-153241	4	COLLAR, 2 PIECE CLAMPING, 2"ID3"OD
3	F-HCF-10M020E	1	FLHC-10.9M10X20
4	LP-247961	2	CM BUSHING, PIVOT
5	MC-138641	4	WASHER; 4.016ID X 4.764OD X 0.048
6	LW-291351	1	CM WLD, PIVOT PIN (JS-9010)
7	F-HC-16M030E	4	M16X2.0X30 HEX HEAD SCREW 10.9
8	F-HNSF-20ME	4	FLHN-10.9M20X2.5 STVR
9	LW-293631	2	CM WLD, AXLE CLAMP (9010)
10	F-HCF-20M220E	2	FLHC 10.9M20X2.50X220 (JD#19M8988)
11	F-HCF-20M120F	2	FLHC-10.9 M20X2.5X120
12	LP-270041	2	CM PLT, CARRIAGE SHIM
13	MC-147781	2	CLAMP 1/4" DOUBLE LOOP 3/8HOLE
14	LW-293560	4	CO WLD, LOWER CARRIAGE SHIM (9010)
15	F-HNJ-16MF	2	HN-8.8 M16 X 1.75 JAM PLT
16	LW-293581	2	CO WLD, UPPER CARRIAGE SHIM (9010)
17	LM-291731	2	CO PLT, CARRIAGE LOCK (9010)
18	HC-139431	6	BEHRINGER TWIN CLAMP -.750 DIA
19	HC-139471	1	STACK BOLT, BEHRINGER 5/16-18
20	F-HC5-05C32	2	HC5 5/16-18 X 2
21	LW-291331	1	CO WLD, BASE
22	HC-139451	2	BEHRINGER TWIN COVER PLT 0.875
23	LM-274901	1	LM PLT, SUPPORT, HYDRO HOSE
24	LA-230552	4	CM PIN ASM, MAIN CYLINDER
25	F-HNF-08ME	2	FLHN-10.9M8X1.25
26	F-HCF-16M110E	8	FLHC-10.9M16X2.0X110
27	F-HNF-16ME	8	FLHN-10.9M16X2.0
28	F-CB-08M030F	1	CARR-8.8M8X1.25X30
29	LW-293491	2	TM PIN ASM, BASE END
30	MC-138651	1	SNAP RING; 4"
31	HC-140342	1	CYL, 3"B,8-3/4"S,1-3/8"R, 17-1/4"CPC, CROSS
32	HA-S-2FP2MN	5	UNION, 1/8" NPSMx1/8" FPT, BULKHEAD
33	HA-NJ-2FN	5	1/8" NPSM BULKHEAD LOCKNUT
34	HC-138011	5	ZERK, GREASE 1/4-28 STR

Model JS9010 Hillco Leveling System  
For Serial Numbers JS9010-13001 thru JS9010-13999

**Undercarriage**

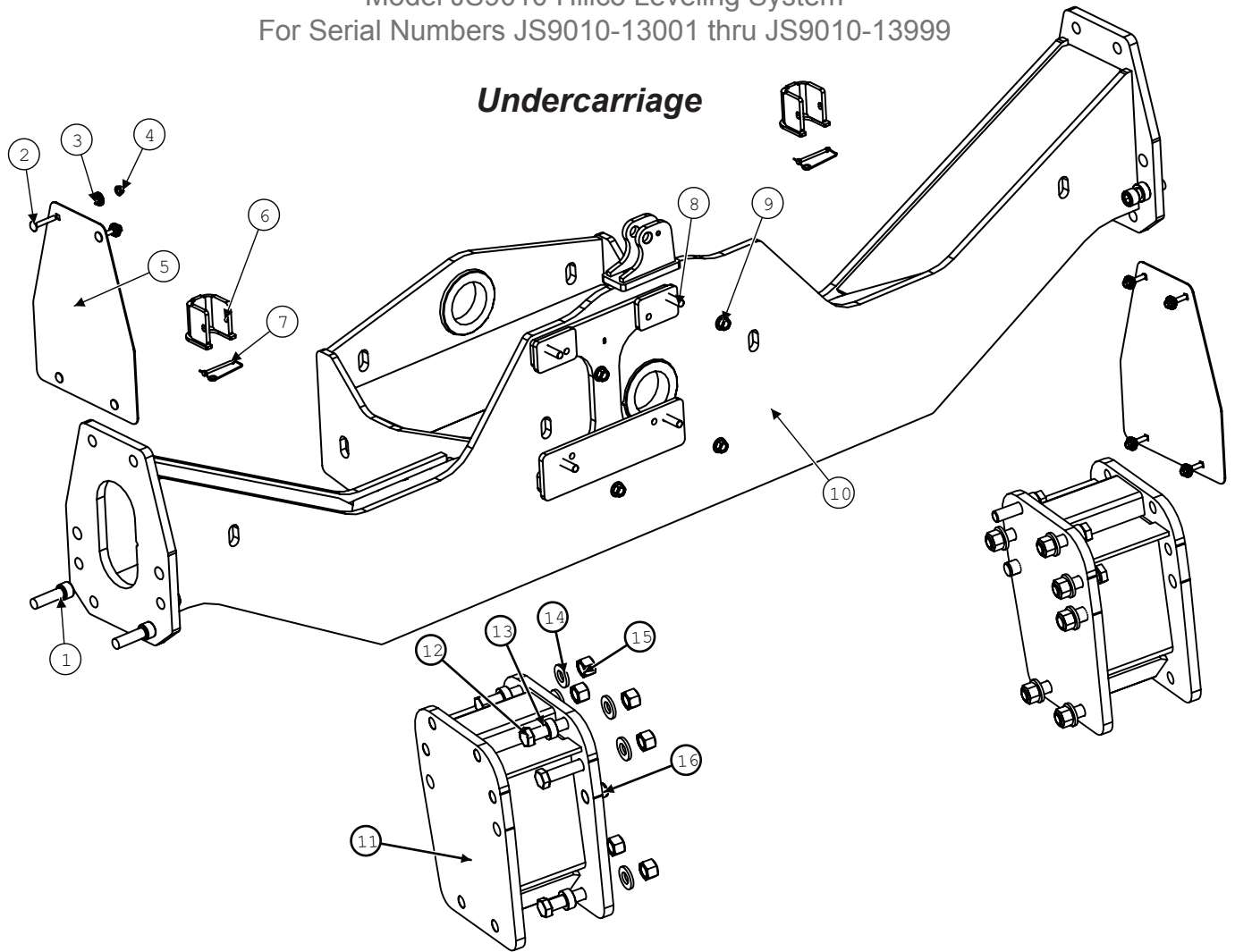

Undercarriage			
BOM ID	Part No.	Qty	Description
1	F-SHC-24M080D	4	SHCS 12.9-M24 X 3 X 80 PLT
2	F-CB-10M050F	8	CARR-8.8M10X1.5X50 HEAD SCREW
3	MC-151021	8	BUSHING, PLASTIC (JD#Z31550)
4	F-HNF-10ME	8	FLHN-10.9 M10 X 1.50
5	LP-293831	2	CM SHT, CAP, AXLE
6	LB-307161	2	LM WLD, CLY STOP
7	F-PSL-04X48	2	SNAP LOCK PIN 1/4 X 3
8	F-STD-16M075E	4	STUD, DOUBLE-10.9 M16X2.00X75
9	F-HNF-16ME	4	FLHN-10.9M16X2.0
10	LM-290811	1	WIDE CARRIAGE
NS	LM-292921	1	NARROW UNDERCARRIAGE
11-16	LA-253141	1	NARROW UNDERCARRIAGE AXLE EXTENSIONS
11	LA-253132	2	LM WLD, 9.25 AXLE EXTENSION
12	F-HC-24M100E	12	M24 X 3 X 110 HEX CAP
13	LM-266382	8	CU TM, SPACER-FINAL DRIVE
14	MC-141121	12	FW M25.4 X 50.0 X 6.0
15	F-HNS-24ME	12	STOVER NUT 24MX3
16	LM-253871	4	LM RND, DOWEL

Model JS9010 Hillco Leveling System  
 For Serial Numbers JS9010-13001 thru JS9010-13999

**Carriage Misc. Parts**

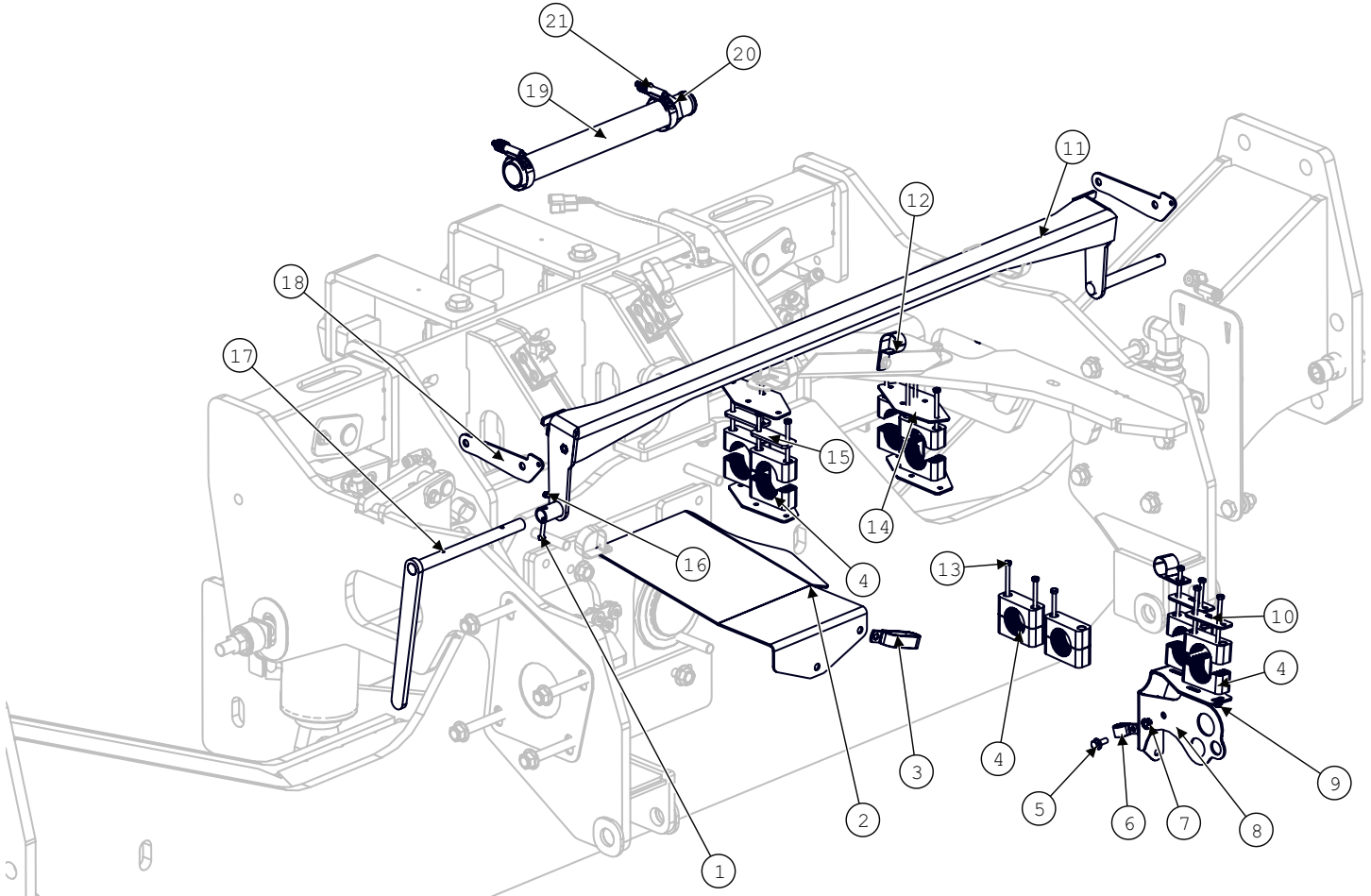

Overcarriage Misc.			
BOM ID	Part No.	Qty	Description
1	F-HC-06M035E	1	HC-10.9 M6x1.0X35
2	LP-274251	1	HM PLT, TABLE HYDRO HOSE
3	MC-151781	1	CLAMP, P-STYLE (JD#AH77884)
4	HC-140641	8	CLAMP, 2" BEHRINGER STD
5	F-HCF-08M020E	1	FLHC-10.9M8X1.25X20
6	HC-135791	1	CLAMP, HOSE 7/8 R/C W 3/8HOLE (JD#AH78237)
7	F-HNF-08ME	1	FLHN-10.9M8X1.25
8	LW-297311	1	LM WLD, HYDRO HOSE SUPPORT
9	F-HNF-06ME	4	FLHN-10.9M6X1.00
10	HC-140651	2	BEHRINGER STD COVER PLATE
11	LA-264511	1	LM ASM, LINKAGE, ROCK TRAP
12	HC-143601	2	CLAMP, HOSE 1-1/8" R/C W 3/8
13	F-HC-06M090F	15	HC-8.8 M6 X 1.00 X 90
14	LP-274231	4	HM PLT, HYDRO HOSE SUPPORT
15	LP-276391	2	HM CLAMP SPACER
16	F-HNN-06MF	1	HN-8.8M6X1.0 NYLOCK
17	LA-264501	1	LM ASM, HANDLE, ROCK TRAP
18	LP-290741	2	LM SHT, ROCK TRAP LINKAGE, UPPER
19	LA-276351	1	HOSE, 1-1/2" BELLOWSFLEX HARDWALL 14"
20	HA-U-24MB24MB	1	UNION, -24MB x -24MB
21	MC-152061	2	CLAMP, HOSE, WORM GEAR, 1.5" TO 2.5"

Model JS9010 Hillco Leveling System  
For Serial Numbers JS9010-13001 thru JS9010-13999

**Carriage Position Sensor**

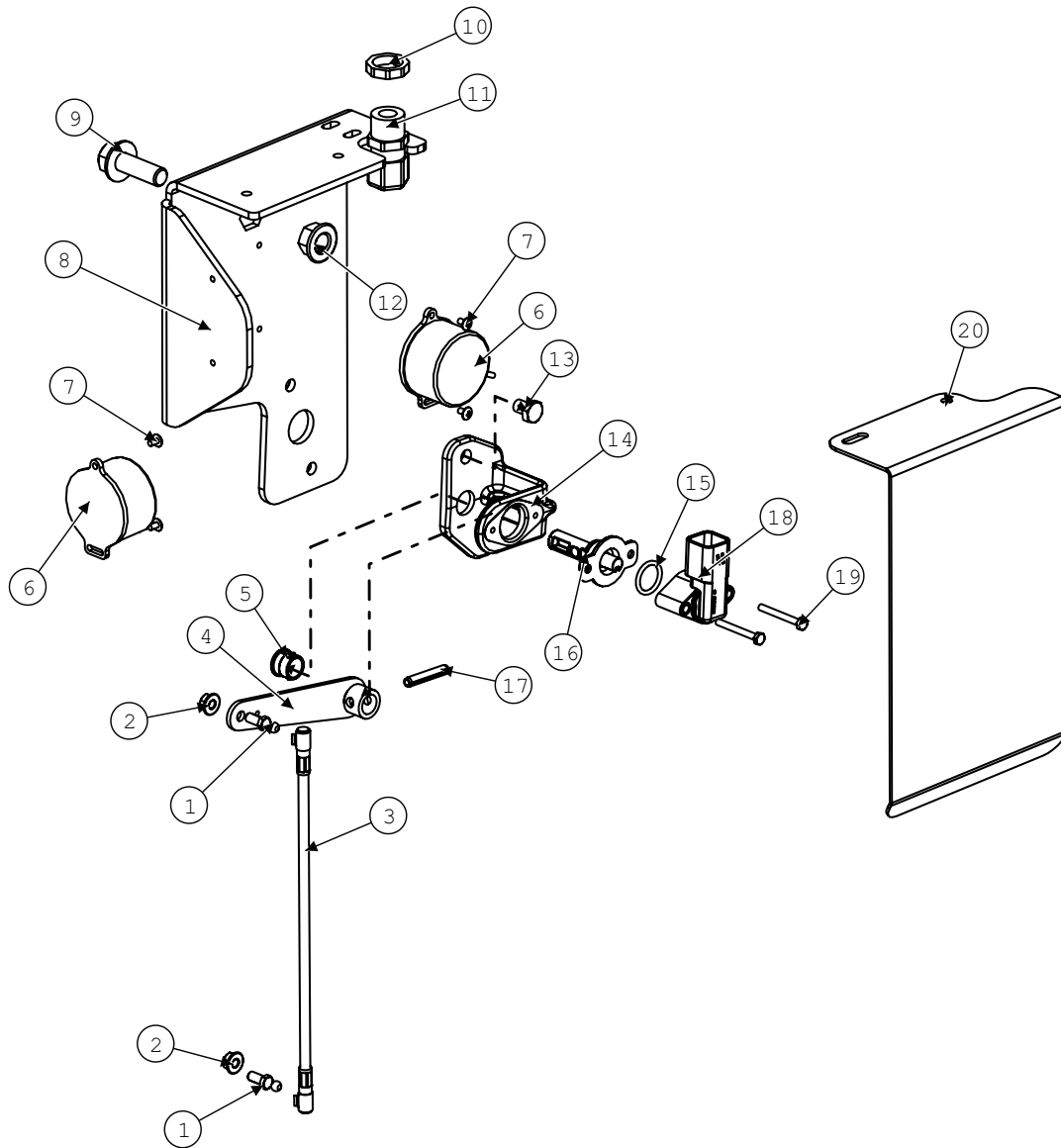

Model JS9010 Hillco Leveling System  
For Serial Numbers JS9010-13001 thru JS9010-13999

Carriage Position Sensor				
BOM ID	Hillco Part No.	John Deere Part No.	Qty	Description
1	MC-151341	H168732	2	BALL STUD (H168732)
2	F-HNF-06ME	-	2	FLHN-10.9M6X1.00
3	MC-151331	AH226146	1	LINKAGE, POSITION (AH226146)
4	MC-151371	AXE17303	1	ARM, ASSY, TILT SENSOR, HM (axe17303)
5	MC-151361	R41076	1	BUSHING, (R41076)
6	EC-141841	-	2	EM ASM, CLINOMETER
7	F-PHM-#C604	-	4	PHMS #6-32X1/4
8	LB-295142	-	1	EM SHT, SENSOR MNT, CLINOMETER
9	F-HCF-12M035E	-	1	FLHC 10.9 M12 X 1.75 X 35 PLT
10	EC-142121	-	1	STRAIN RELIEF NUT, 1/2" BLACK
11	EC-138781	-	1	STRAIN RELIEF, NYLON, BLK,
12	F-HNF-12ME	-	1	FLHN-10.9 M12 x 1.75 PLT
13	F-HC-08M010F	19m7008	2	HC-8.8M8X1.25X10 (19m7008)
14	MC-151321	HXE16001	1	BRACKET, SENSOR MNT (HXE16001)
15	MC-151391	P48347	1	O-RING, 11/16ID (P48347)
16	MC-151401	AXE14888	1	SHAFT, ROUGH SERVICE DEVICE (AXE14888)
17	F-PR-06Mx36	-	1	PIN, ROLL 6mm x 36mm
18	EC-151381	AXE14246	1	SENSOR, ROTATION, HALL 2CH +/-120DE (axe14246)
19	F-HC-04M035E	19M9368	2	HC-8.8M4X0.7X035 (19m9368)
20	LB-303151	-	1	EM SHT, SHIELD SENSOR



Model JS9010 Hillco Leveling System  
For Serial Numbers JS9010-13001 thru JS9010-13999

**DROP AXLE**

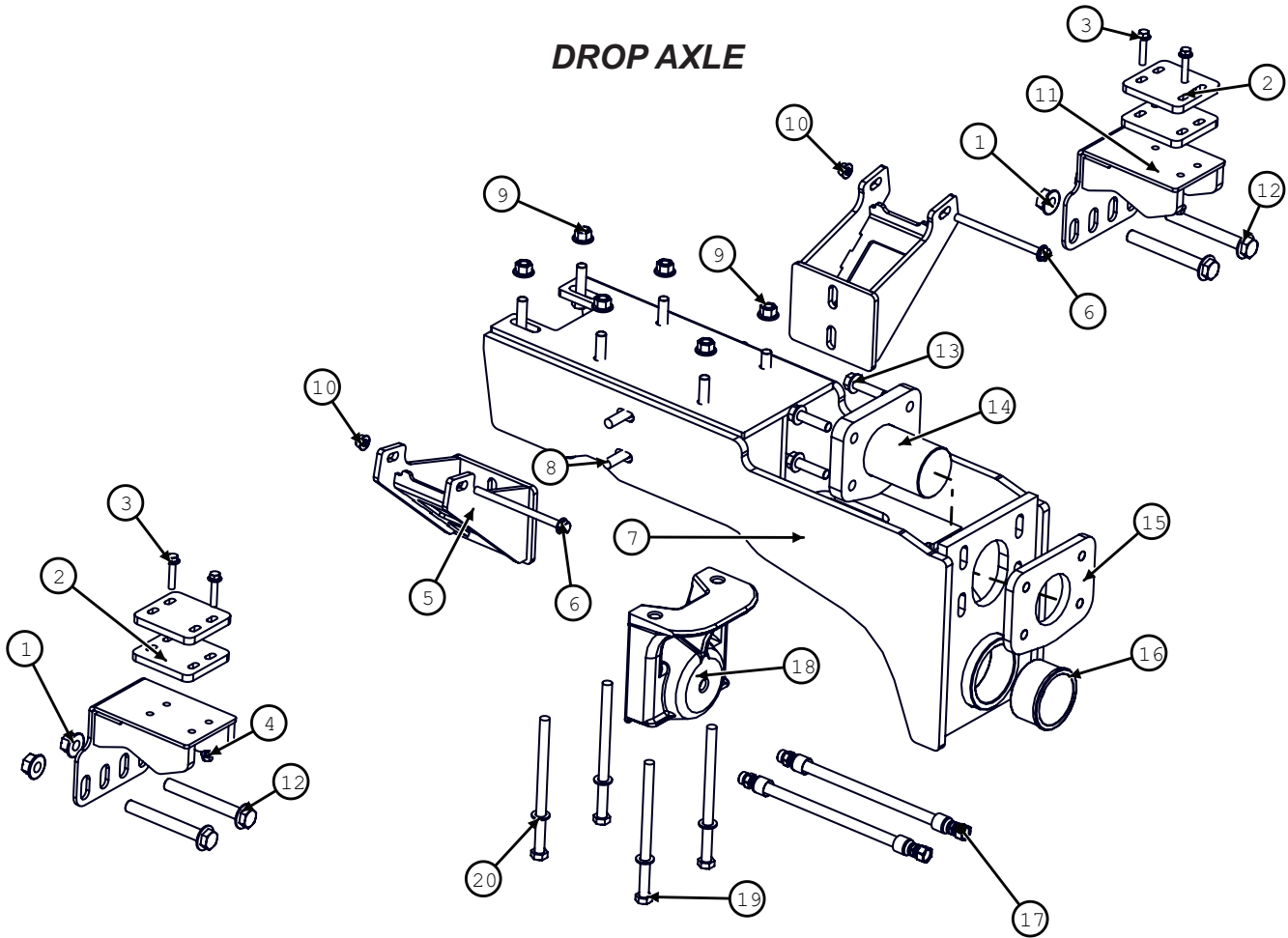

Drop Axle			
BOM ID	Part No.	Qty	Description
1	F-HNF-20ME	4	FLHN-10.9 M20X2.50
2	LP-299892	4	DA PLT, ROTATION STOP 16°
3	F-HCF-10M050E	4	SCREW, FLANGED HEX CAP
4	F-HNSF-10ME	4	FLHN-10.9 M10X1.5 STV
5	LW-299841	2	DA WLD, WING
6	F-HCF-12M180E	2	FLHC-10.9M12X2.0X180 (ONLY ON EARLY MY 13 COMBINES)
7	LW-291021	1	DROP AXLE SPACER
8	F-CB-16M050E	4	CARR-10.9M16X2.0X90
9	F-HNSF-16ME	10	FLHN-10.9M16X2.00 STV
10	F-HNFS-12ME	2	FLHN-10.9M12X1.75 STVR
11	LW-299792	2	DA WLD, ROTATION STOP
12	F-HCF-20M160E	4	FLHC-10.9 M20X2.5X160
13	F-HCF-16M060E	10	FLHC-10.9 M16 X 2.0 X 60
14	LW-291071	1	DA WLD, PIVOT
15	LP-291091	1	DA PLT, PVOT LOCK
16	LP-235092	1	LM BUSHING, DA PIVOT
17	LA-273461	2	HOSE, 3/8" R2 #8FF#8MF 15"
18	LM-299801	1	DA STAND-OFF, REAR AXLE
19	F-HC-16M250E	4	M16X2.0X250 HEX HEAD SCREW
20	F-FW-10	4	WASHER, FLAT, 5/8

Model JS9010 Hillco Leveling System  
For Serial Numbers JS9010-13001 thru JS9010-13999

**Hydraulic Components**

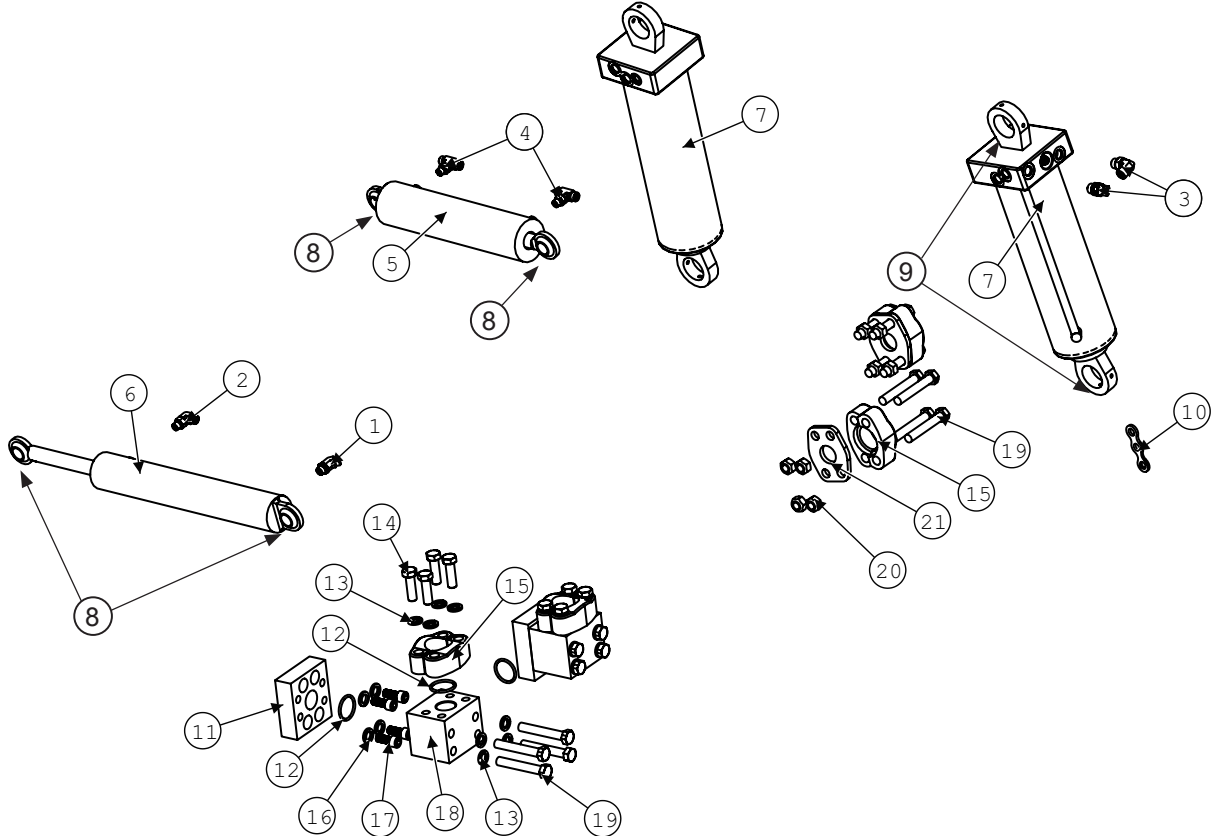

Hydraulic Components			
BOM ID	Part No.	Qty	Description
1	HA-S-6MF6MO	2	#6 MORS X #6 MORB 45 DEG
2	HA-L-6MF6MO	2	ELBOW, 90°, 6MF x 6MO
3	HA-L-8MF8MO	3	ELBOW, 90°, #8MORS#8MORB
4	HA-Q-06MF06MO	5	TEE, STRAIGHT THREAD, BRANCH -6MF x -6MO
5	HC-140342	2	MASTER CYLINDER, 3"B, 8-3/4"S,1-3/8"R, 17-1/4"CPC, CROSS
NS	HC-134201	-	SEAL KIT, MASTER CYLINDER
6	HC-138582	4	SLAVE CYLINDER, 2-1/2 B, 1-1/8" R, 12-1/2" S, 21" CPC
NS	HC-141281	-	SEAL KIT, SLAVE CYLINDER
7	HC-151002	2	LEVELING CYLINDER, 4-1/2"B,11"S,2"R, 22-1/2 CPC
NS	HC-135221	-	SEAL KIT, LEVELING CYLINDER
8	MC-140321	4	1" BEARING, SEALED SPHERICAL
9	MC-150881	4	1 3/8" BEARING, SEALED SPHERICAL
10	LP-274391	1	LM PLT, HYDRO HOSE SPACER
11	LM-272092	2	CODE 62 90° 1-1/4 ROTATIONAL ADAPTER
12	HC-147621	8	O-RING, CODE 62, 1-1/4"
13	F-LW-09	16	LW 9/16 HD
14	F-HC-14M045E	8	HC-10.9M14 X2.0X45
15	HC-147611	8	FLANGE, 1-1/4" CODE 62, HALF
16	F-LWHC-09	8	LW 9/16 HD HIGH COLLAR
17	F-SHC-14M030D	8	SHCS-12.9M14X2.0X30
18	LM-272082	2	HM BLOCK, CODE 62 1-1/4 90°
19	F-HC-14M090E	16	HC-10.9 M14X2.0X90
20	F-HNS-14ME	8	HN-10.9M14X2.0 STVR
21	LM-272161	2	HM PLT, CODE 62 1-1/4 UNION

Model JS9010 Hillco Leveling System  
 For Serial Numbers JS9010-13001 thru JS9010-13999

**Single Station Leveling Manifold**

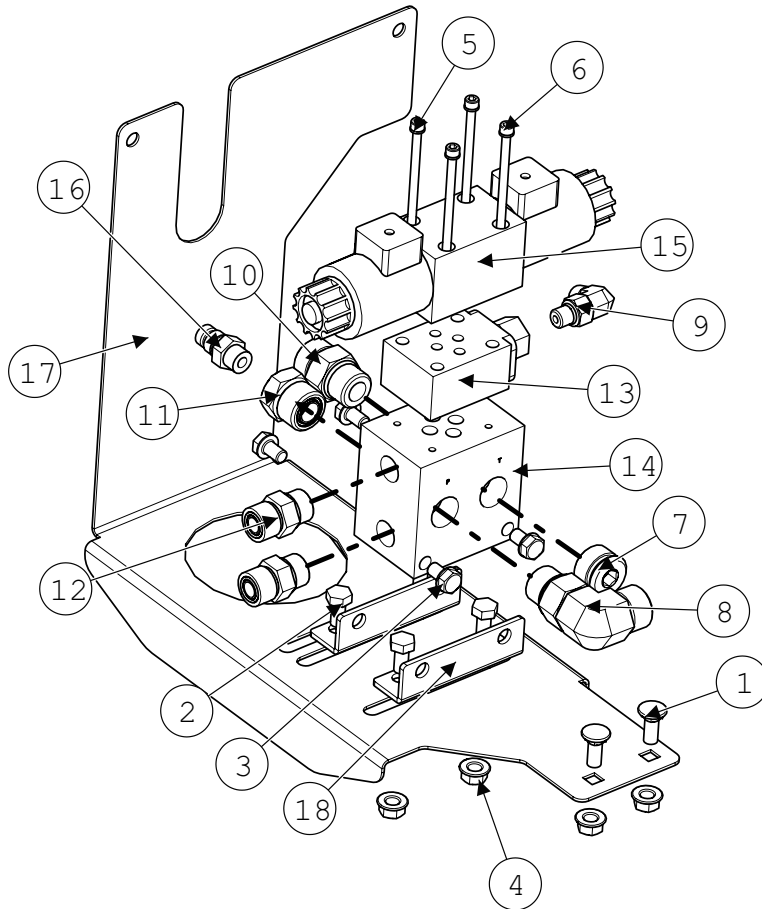

Single Station Manifold			
BOM ID	Part No.	Qty	Description
1	F-CB-08M020F	2	CARR-8.8M8X1.25X20 HEAD SCREW
2	F-HC-8M016F	4	HC-8.8 M8 X 1.25 X 16 PLT
3	F-HCF-05C08	4	FLHC 5/16-18 X 1/2 SERRATED
4	F-HNF-08ME	6	FLHN-10.9M8X1.25
5	F-LW-#10	4	LOCK WASHER #10
6	F-SHC-#10C-52	4	SOCKET HEAD #10 X 3.25 COARSE
7	HA-E-10MO	1	#10 MORB SOCKET HEAD PLUG
8	HA-L-10MF10MO	1	#10 MORB X #10 MORS 90DEG
9	HA-L-4MF4MO	1	#4 MORB X #4 MORS 90 DEG
10	HA-S-10MF10MO	1	#10 MORS X #10 MORB STRAIGHT
11	HA-S-6FO10MO	1	#6 FORB X #10 MORB STRAIGHT
12	HA-S-8MF8MO	2	#8 MORS X #8 MORB STRAIGHT
13	HC-101264	1	VALVE ASM, LOAD SENSE SHUTTLE
14	HC-138861	1	MANIFOLD, SINGLE STATION
15	HC-140411	1	VALVE, DIRECTIONAL CONTROL
16	HC-143991	1	COUPLER, QUICK-CONNECT HYD
17	LB-296131	1	HM PLT, MANIFOLD MNT
18	LP-267511	2	MNT, MANIFOLD

**John Deere Header Lift Manifold Fittings**

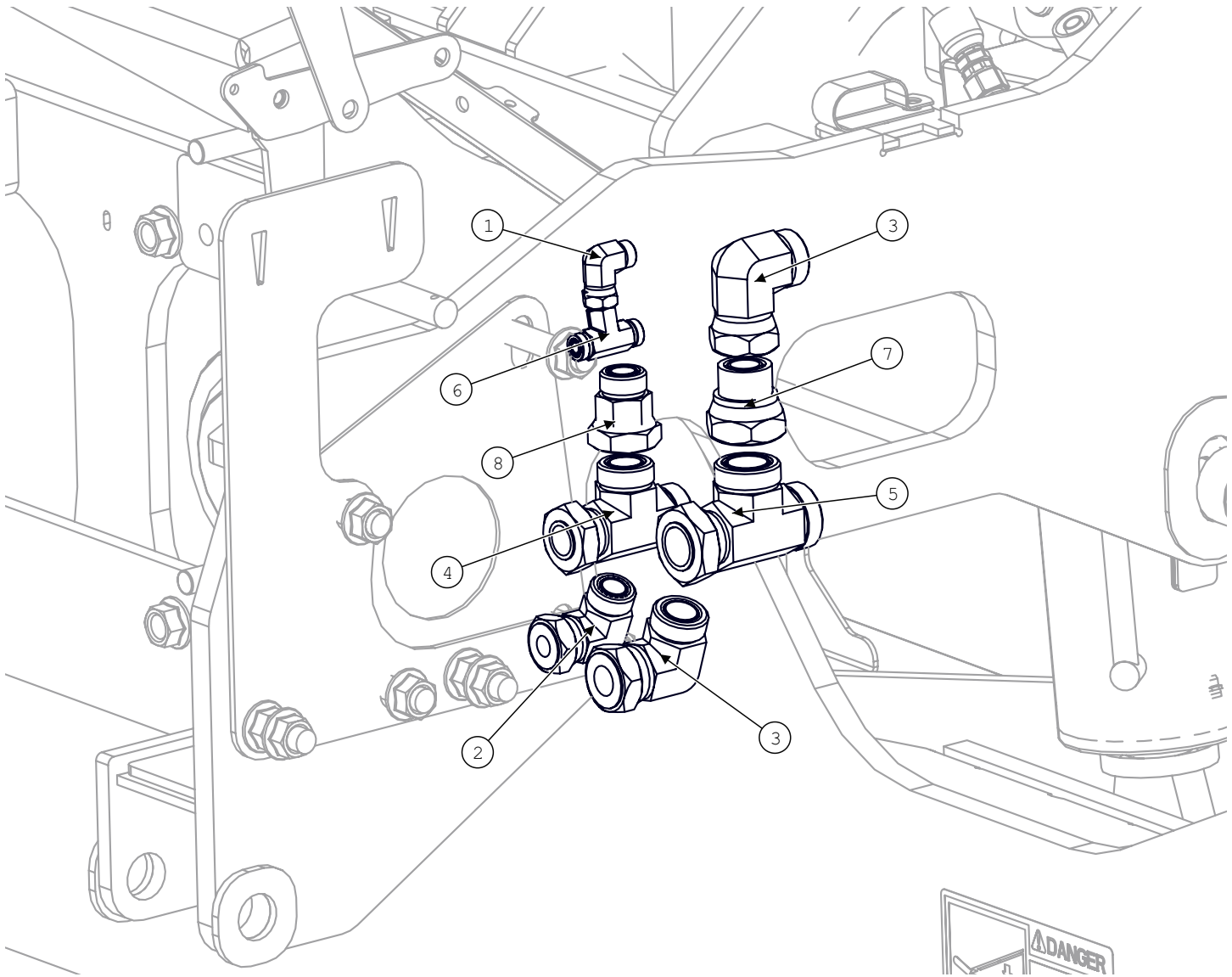

John Deere Header Lift Manifold Fittings			
BOM ID	Part No.	Qty	Description
1	HA-L-06FF06MF	1	ELBOW, 90°, -6FF x -6MF
2	HA-L-12MF12FF	1	ELBOW, 90°, -12MF x -12FF
3	HA-L-16FF16MF	2	ELBOW, 90°, -16MF x -16FF
4	HA-M-16FF16MF	1	TEE, SWIVEL NUT, RUN, #16
5	HA-M-20FF20MF	1	TEE, SWIVEL NUT, RUN, #20
6	HA-M-6FF6MF	1	TEE, SWIVEL NUT, RUN, -6FF x -6MF
7	HA-S-20FF16MF	1	STR, -20FF x -16MF
8	HA-S-16FF12MF	1	STR, 16FF x 12MF

Model JS9010 Hillco Leveling System  
For Serial Numbers JS9010-13001 thru JS9010-13999

### Hydraulic Hoses

Hydraulic Hoses			
Part No	Qty	Description	Hose Specs
LA-138942	1	Grease Hose	HOSE, 100R1-03, 33-1/2" 1/8 MPT X 1/8 MPT
LA-138951	1	Grease Hose	HOSE, 100R1-03, 40" 1/8 MPT X 1/8 MPT
LA-138963	1	Grease Hose	HOSE, 100R1-03, 54" 1/8 MPT X 1/8 MPT
LA-138974	2	Grease Hose	HOSE, 100R1-03, 77" 1/8 MPT X 1/8 MPT
LA-152451	1	Connect Yellow Port to Slave Cyl Base Port	HOSE ASM, 100R2-04 80", -6FF STR x -6FF 90°
LA-152461	1	Connects C/M Blue Port to Rod Port	HOSE ASM, 100R2-04 70", -6FF STR x -6FF 90°
LA-273461	2	Extends Steer Hoses	HOSE, 3/8" R2 #8FF#8MF 15"
LA-273462	2	Filter head; Front & Side Port to Valve Block Ports	HOSE ASM, 100R2-08 62", #10FF x #8FF 90°
LA-274141	1		HOSE ASM, 100R15-20 124", 90° XR FLNG x STR FLNG
LA-293431	2	Extends Rear Hydrostat Line	HOSE, 100R2-06 47" #8FORS #8FORS 90°
LA-295601	2	Leveling Manifold to Leveling Cyl	HOSE, 100R2-08, 103" 08FORSx08FORS
LA-295882	2	Connects Master Cyl to Slave Cyl	HOSE, 100R2-06 X 195" -.06FF STR x -06FF STR
LA-297421	1	Extends AH226084 to Proportionator Motor Supply	HOSE ASM, 100R2-10 66", -10FF 90° x -10MF STR
LA-297441	1	Extends AH226085 to Proportionator Pump Supply	HOSE ASM, 100R1-12 66", -12FF 90° x -12MF STR
LA-297451	1	Replaces AH219243; Connects Rear Filter Port to Proportionator Motor Return	HOSE ASM, 100R2-10 147", -10FF STR x -10FF 90°
LA-297481	1	Extends AH226119 to the Trans Lube	HOSE ASM, 100R2-06 31", -6FF 90° x -6MF STR
LA-297641	1	Extends Right Brake Hose	HOSE ASM, 100R2-06 78", -06MF STR x -06FF 90°
LA-297651	1	Extends Left Brake Line; Extends Lube Line	HOSE ASM, 100R2-06 60", -06MF STR x -06FF STR
LA-297841	1	Return, Manifold to Tee	HOSE ASM, 100R1-12 68", -16 90° x -10 STR
LA-297851	1	Pressure, Manifold to Tee	HOSE ASM, 100R2-10 72", -12 90° X -10 STR
LA-297862	1	Load Sense, Manifold to Tee	HOSE ASM, 100R2-04 80", -6 STR x -4 90°
LA-297922	1	Replaces JD Hose; Connects Manifold to Tee	HOSE ASM, 100R16-12 91", -12FF 90° x -12FF STR
LA-297932	1	Replaces Left Header Lift Pressure Hose	HOSE ASM, 100R16-12 44", -12FF STR x -12FF STR
LA-298291	1	Extends ProDrive Case Drain	HOSE ASM, 100R1-16 36", -16MF x -16FF
LA-298321	1	Replaces Right Header Lift Pressure Hose	HOSE ASM, 100R16-12 42", -12FF STR x -12FF 90°
LA-298331	1	Replaces the Header Lift Pressure Hose	HOSE ASM, 100R17-16 90", -16FF STR x -16FF 90°
LA-299191	1	Extends JH Hose to Shift Block	HOSE ASM, 100R2-04 15", -6FF 90° X -6MF STR
LA-305181	1	Replaces Forward Hydro Hose	HOSE ASM, 100R15-20 121", 90° MR FLNG x STR FLNG

Model JS9010 Hillco Leveling System  
For Serial Numbers JS9010-13001 thru JS9010-13999

**RETRACTABLE LADDER**

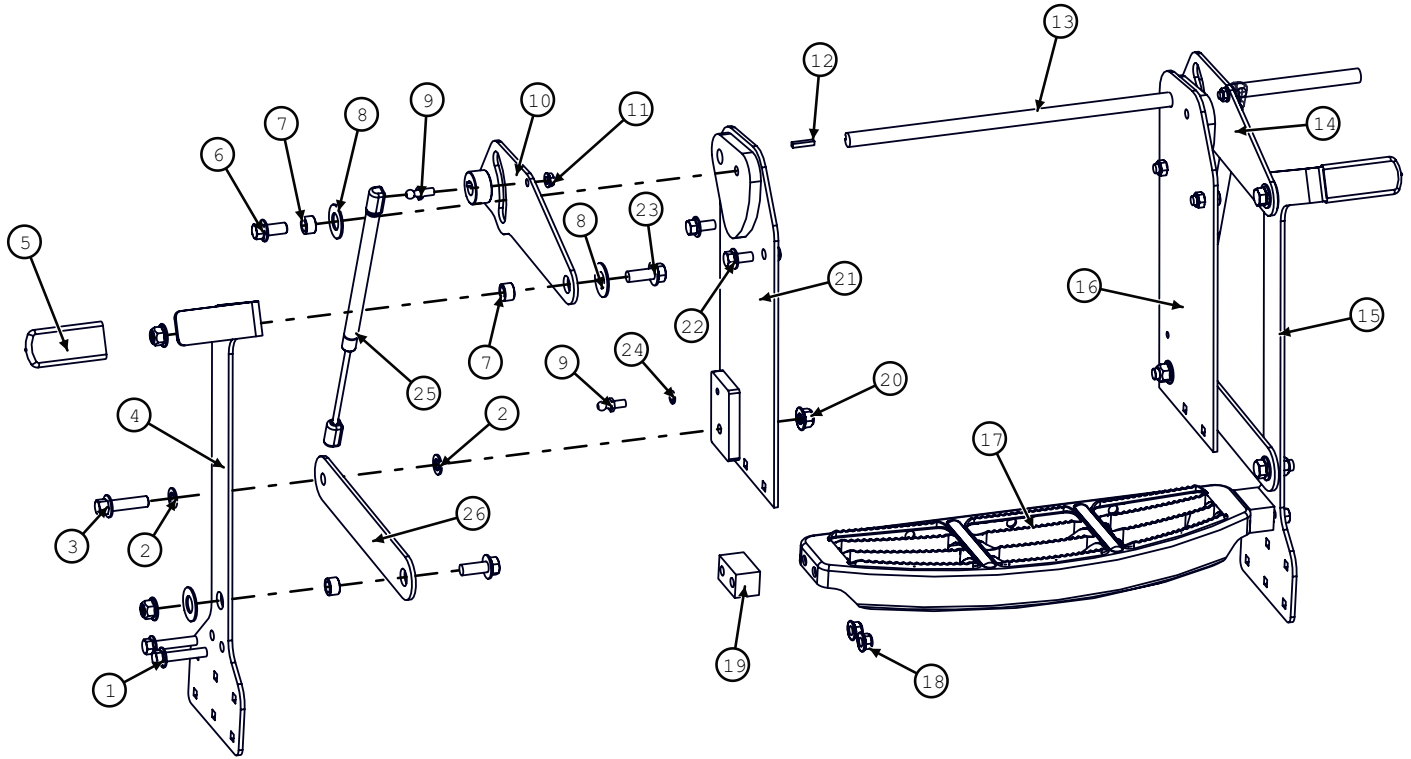

Model JS9010 Hillco Leveling System  
For Serial Numbers JS9010-13001 thru JS9010-13999

**Retractable Ladder**

<b>BOM ID</b>	<b>Part No.</b>	<b>Qty</b>	<b>Description</b>
ASM	LA-297171	1	LM ASM, MOVING STEP (SIDEHILL)
1	F-HCF-10M050E	4	SCREW, FLANGED HEX CAP
2	F-MB-14NR08	4	MACHINE BUSHING 14GA NR 1/2ID
3	F-HCF-12M045E	2	FLHC-10.9M12X1.75X45
4	LB-298222	1	LM PLT, LADDER HANDLE, RIGHT
5	MC-151921	2	GRIP, JD#W25634
6	F-HCF-12M025E	2	FLHC-10.9M12X1.75X25
7	LM-299181	6	LM BUSHING, LADDER PIVOT
8	153.014.012	6	BUSHING, MACH, WR
9	MC-134931	2	LIFT SUPPORT BRACKETS (PAIR)
10	LW-298272	1	LM ASM, UPPER CONTROL LINK, RIGHT
11	F-HNF-05C	2	FLHN 5/16-18
12	F-KST-03X03X16	2	KEY, STR, 3/16 X 3/16 X 1
13	LM-298191	1	LM RND, ROCK SHAFT
14	LW-298252	1	LM WLD, UPPER CONTROL LINK
15	LB-298182	1	LM PLT, LADDER HANDLE, LEFT
16	LM-298132	1	LM WLD, LFT LADDER MNT
17	MC-152601	1	STEP, PLATFORM, STEP (HXE19816)
18	F-HNFS-10ME	8	FLHN-10.9M10X1.5 STVR
19	LM-299071	2	LM SPACER, LADDER STEP
20	F-HNFS-12ME	6	FLHN-10.9M12X1.75 STVR
21	LM-298212	1	LM WLD, RHT LADDER MNT
22	F-HCF-10M020E	4	FLHC-10.9 M10X1.75X20
23	F-HCF-12M30E	4	FLHC-10.9 M12X1.75X30
24	F-LW-05	2	LOCK WASHER 5/16"
25	MC-139251	2	GAS CHARGED LIFT SUPPORT
26	LM-298171	2	LM PLT, LOWER CONTROL LINK

### Ladder Wedge

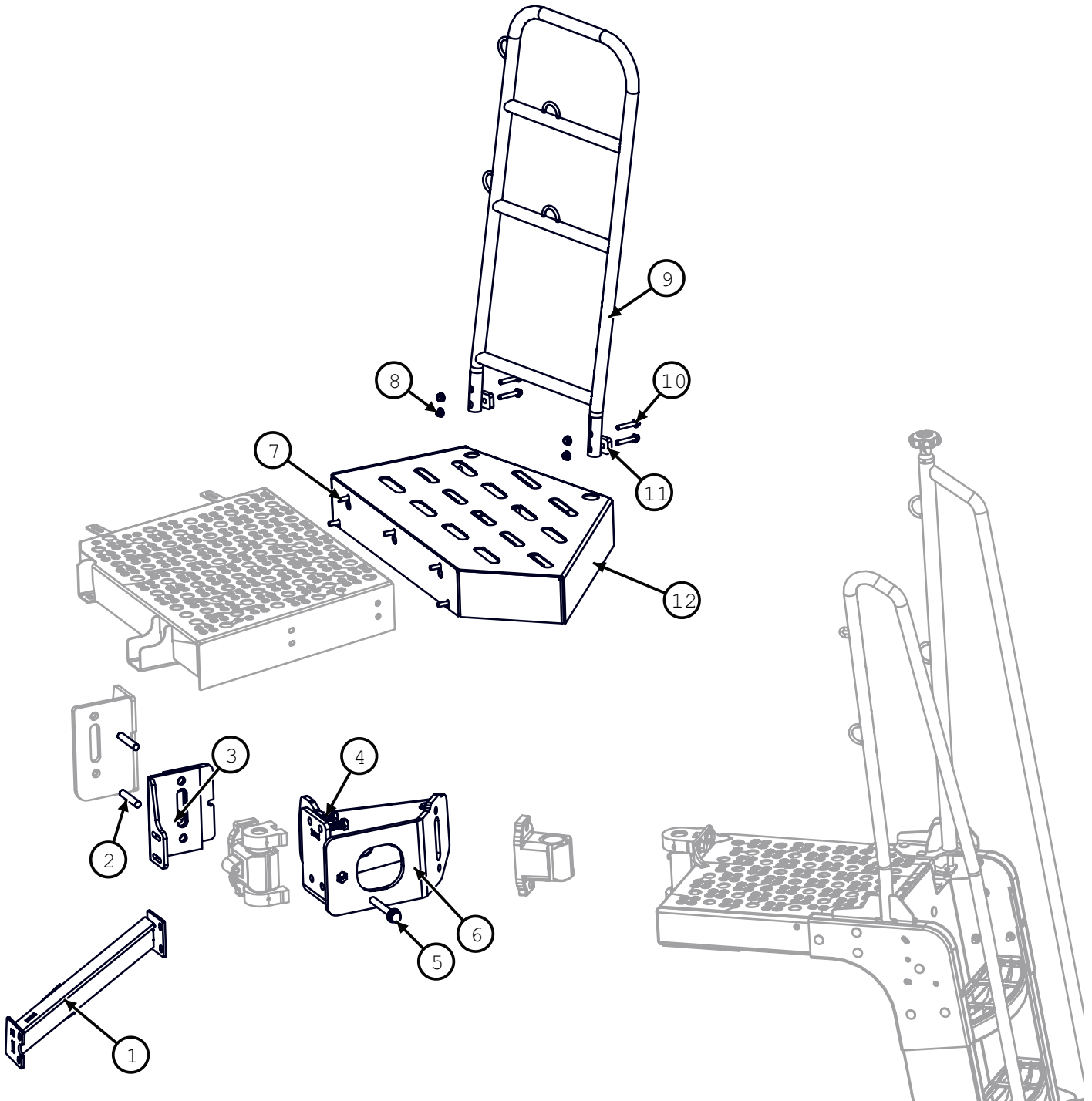



Model JS9010 Hillco Leveling System  
For Serial Numbers JS9010-13001 thru JS9010-13999

**Ladder Wedge**

<b>BOM ID</b>	<b>Part No.</b>	<b>Qty</b>	<b>Description</b>
1	LW-296081	1	LM WLD, LADDER BRACE
2	F-STD-16M90E	2	STUD, DOUBLE-10.9 M16X2.00X90
3	LW-301181	1	LM ASM, SUPPORT BRACKET
4	F-HC-16M040E	4	HC 10.9M16X2.0X40
5	F-HCF-16M120E	1	
6	LW-300931	1	LM WLD, PIVOT EXTENSION
7	F-HCF-10M030E	5	FLHC 10.9 M10 X 1.5 X 30
8	F-HNF-10ME	4	FLHN-10.9 M10 X 1.50
9	MC-153571	1	HANDRAIL, EXTENSION ASSY FRONT ( AXE16380)
10	F-HCF-10M060E	4	FLHC-10.9M10X1.50X060
11	LP-307281	2	LM PLT, SPACER, PLATFORM
12	LW-301102	1	LM WLD, PLATFORM

### Controller/Wiring Harnesses

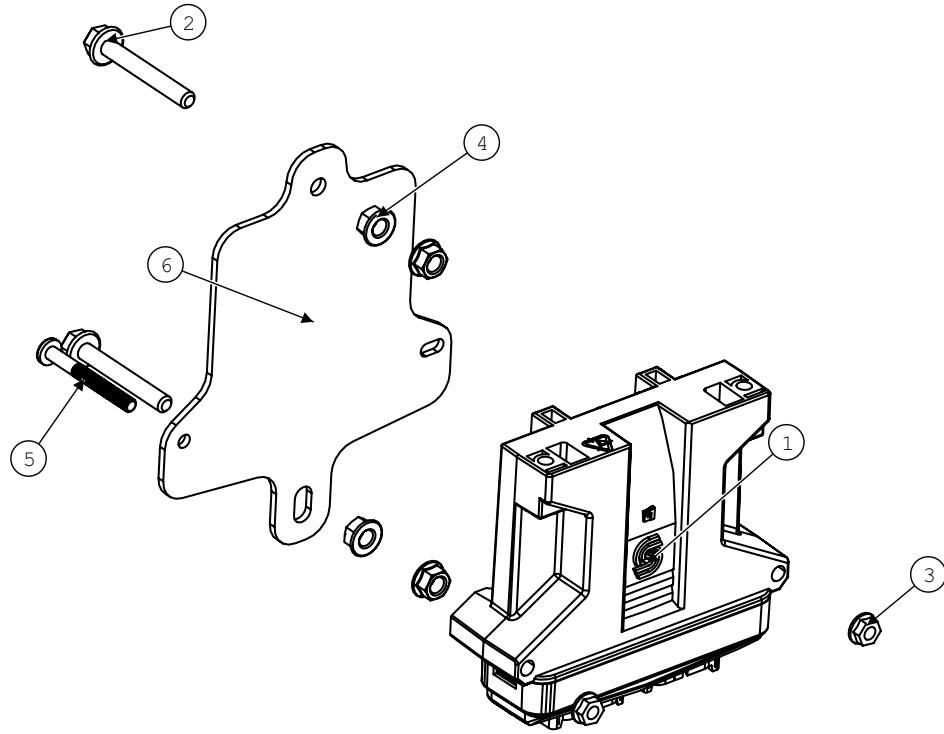

Electrical Components			
BOM ID	Part No.	Qty	Description
1-6	LA-297671	1	EM ASM, CONTROLLER W/MNT
1	EC-141831	1	SAUER-DANFOSS PLUS 1 CONTROLLER
2	F-HCF-08M060E	2	FLHC-M08X1.25X60
3	F-HNF-04F	2	FLHN-GR5 1/4-20
4	F-HNF-08ME	4	FLHN 10.9 M8 X 1.25
5	F-PHM-04C36	2	PHMS-GR5-1/4-20 X 2-1/4"
6	LP-295201	1	EM PLT, CONTROLLER MNT

Wiring Harnesses			
BOM ID	Part No.	Description	Purpose
NS	LA-294742	EM HARNESS, PRIMARY	POWER SUPPLY & SENSOR PACKAGE
NS	LA-295341	EM HARNESS, TA SENSOR	TRANSITION TILT SENSOR
NS	LA-296221	EM HARNESS, HEADER TRIM	PROPORTIONAL CONTOUR MASTER TRIM
NS	LA-295181	EM HARNESS, SENSOR PACKAGE	SENSOR PACKAGE WIRING
NS	LA-294821	EM HARNESS, MANIFOLD CABLE, PFC	OPEN CENTER PUMP MANIFOLD
NS	LA-294752	EM HARNESS, SECONDARY	SIGNALS TO MANIFOLD, TRANSITION SENSOR

Model JS9010 Hillco Leveling System  
 For Serial Numbers JS9010-13001 thru JS9010-13999  
**Decals and Literature**



1) LL-133741



3) LL-153691

2) LL-151041

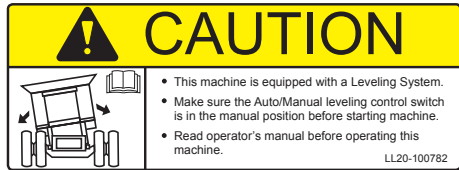

4) LL20-100782



6) LL20-100784



5) LL20-100783

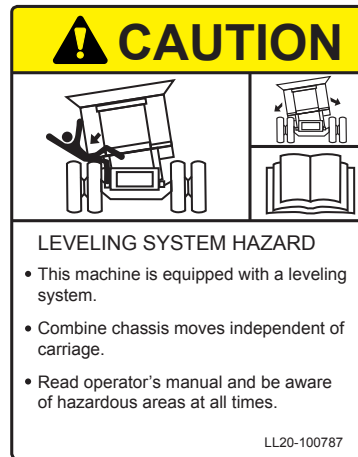

8) LL20-100787



7) LL20-100786



9) LL20-100788



10) LL-143621

Model JS9010 Hillco Leveling System  
For Serial Numbers JS9010-13001 thru JS9010-13999

DECALS AND LITERATURE				
REF.	PART NO.	QTY.	PART NAME	DESCRIPTION
1	LL-133741	1	LABEL, GREASE 50 HRS	OC BULKHEAD
1	LL-133741	2	LABEL, GREASE 50 HRS	RIGHT & LEFT MAIN LEV CYL BOTTOM
1	LL-133741	1	LABEL, GREASE 50 HRS	MASTER CYLINDER ROD
2	LL-151041	2	DECAL, HILLSIDE LEVELING SYSTEM	SIDE OF COMBINE
3	LL-153691	2	DECAL, 20 YEAR ANIVERSARY	SIDE OF COMBINE
4	LL20-100782	1	CAUTION LEVELING SYSTEM CAB	WINDOW IN CAB
5	LL20-100783	2	DANGER, CRUSHING HAZARD	RIGHT & LEFT UNDERCARRIAGE
5	LL20-100783	2	DANGER, CRUSHING HAZARD	SIDES OF DROP AXLE ASSEMBLY
6	LL20-100784	2	DECAL, DANGER PINCH POINT	RIGHT & LEFT UPPER TRANS FACE PLT
7	LL20-100786	1	WARNING ELECTRICAL CRUSHING HAZARD	FRONT OF ELECTRICAL CONTROL BOX
8	LL20-100787	1	CAUTION - LEVELING SYSTEM HAZARD	ON LADDER PLATFORM
9	LL20-100788	1	DANGER - HYDRAULIC HAZARD	ON SIDE OF COMBINE ABOVE THE HYDRAULIC MANIFOLD
9	LL20-100788	2	DANGER - HYDRAULIC HAZARD	FOR EACH LEVELING CYLINDER
10	LL-143621	2	DANGER, AVOID CRUSHING INJURY	IN AREA NEAR SAFETY STOP STORAGE LOCATION
NS	LL-147651	1	LABEL, FEMA MEMBER TAG	NEAR SERIAL NUMBER TAG
NS	LA-255961	1	TAG, SERIAL NUMBER	
NS	LL-289641	1	CM LABEL, MECHANICAL CYLINDER STOP	
NS	D-120620CMA01A	1	MANUAL, PARTS	
NS	D-111124CMA01B	1	MANUAL, OPERATORS	
NS	D-050611SLR01	1	WARRANTY REGISTRATION CARD	
NS	LL-239412	1	LABEL, STEERING WHEEL	TIED TO STEERING WHEEL DURING INSTALLATION
NS	D-120412CMA01	3	DEALER PDI & INSTALL CHECKLIST	

Model JS9010 Hillco Leveling System  
For Serial Numbers JS9010-13001 thru JS9010-13999

***Notes***

Model JS9010 Hillco Leveling System  
For Serial Numbers JS9010-13001 thru JS9010-13999

Hillco Technologies, Inc.  
107 1st Avenue  
Nezperce, Idaho 83543

Phone	800-937-2461
	208-937-2461
Fax	208-937-2280

[www.hillcotechnologies.com](http://www.hillcotechnologies.com)  
email: [support@hillcotechnologies.com](mailto:support@hillcotechnologies.com)