

Model JH9010 Hillco Leveling System
For Serial Numbers JH9010-15001 thru JH9010-15999



Model JH9010 Hillside Leveling System Parts Manual

SN JH9010-15001 thru JH9010-15999

For John Deere S680 & S690
S Series Combines

D-120613CMA01D



JH9010 Hillside Leveling System

For S680 & S690 S Series Combines

Table of Contents

General Information	3
Serial Number Location	3
Text and Illustrations	3
Abbreviations	3
Right and left Identification	3
Part Orders	3
Transition	4
Transition Throat	5
Transition Beater Drive	7
Radial Pin Slip Clutch	9
Transition Middle	10
Header Position Sensor Tilt Sensor	11
Transition Header Adapter	12
Carriage	13
Overcarriage	14
Undercarriage	16
Carriage Misc. Parts	17
Carriage Position Sensor	18
Drive Wheel	20
Drop Axle	21
Hydraulic Components	22
Leveling Manifold	23
Header Trim Manifold	25
John Deere Header Lift Manifold Fittings	27
Retractable Ladder	29
Ladder Wedge	31
Electrical	33
Controller/Wiring Harnesses	33
Monitor	34
Decals and Literature	35

Contact Information

Hillco Technologies, Inc.
107 1st Avenue
Nezperce, Idaho 83543

Phone	800-937-2461
	208-937-2461
Fax	208-937-2280

www.hillcotechnologies.com
email: support@hillcotechnologies.com

GENERAL INFORMATION

SERIAL NUMBER LOCATION

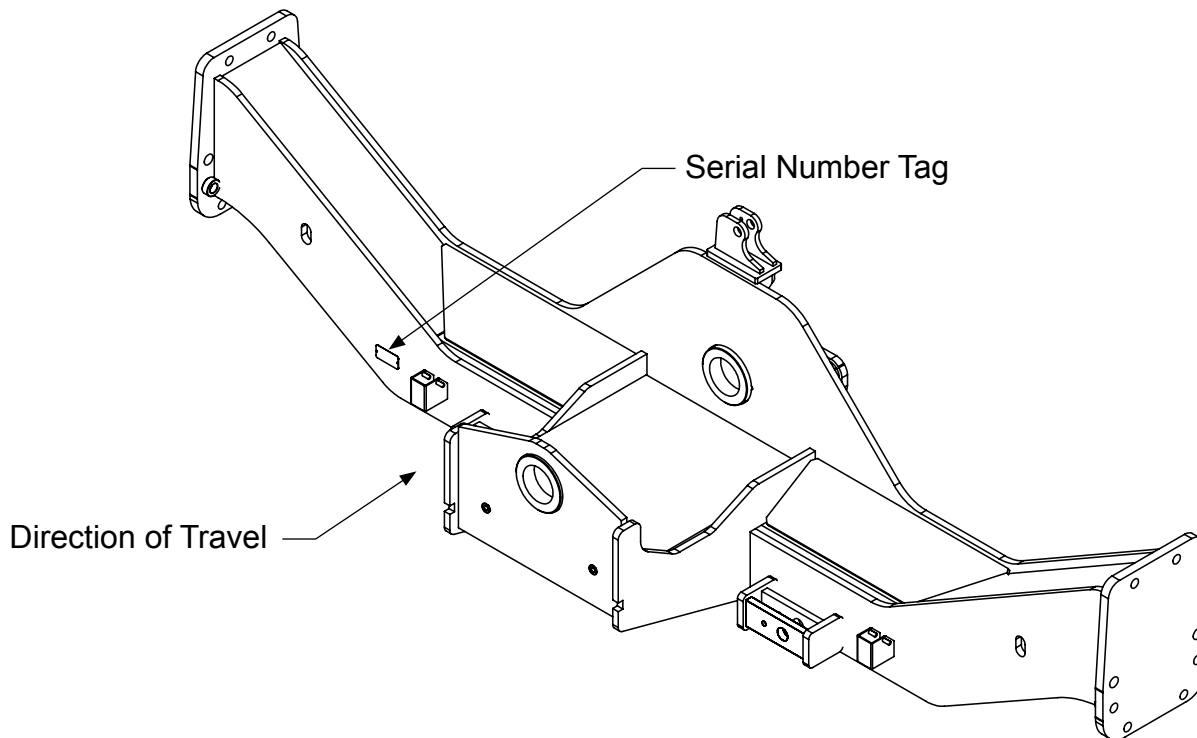

TEXT AND ILLUSTRATIONS

The arrangement of this parts catalog is for easy identification of parts. All parts are illustrated in exploded views in proper relation to each other. Some diagrams refer to other pages for further information. Reference numbers used in the illustrations refer to line numbers in the part lists. The part lists appear to the right or below all diagrams and correspond with those diagrams. Included in the part lists, along with the reference numbers are part numbers, part descriptions and the quantity of the part required per leveling system.

ABBREVIATIONS

SN "Serial Number" refers to the serial number given to each leveling system (by Hillco Technologies), as well as the serial number given to the combine (by the specific combine manufacturer) the leveling system is installed. See above for the leveling system's serial number location. This abbreviation is used interchangeably in both instances. Each Model JH9010 Leveling System uses the following serial number format: JH9010-XXXXX (sequential numbers).

ASM "Assembly" refers to a whole grouping of parts (shown in the diagram corresponding with the page where "ASM" is shown unless otherwise noted). Some assemblies have parts that are sold separately, however some must be purchased as a single unit. Hillco Product Specialists will be able to assist you with any questions.

NS "Not Shown" refers to a part that is not depicted in the illustration.

RIGHT AND LEFT IDENTIFICATION

The reference to right-hand and left-hand in this catalog is identified by the operator sitting in the operator's seat, looking toward the front of the machine (in normal forward travel).

PART ORDERS

Orders must specify product model, serial number, correct part number, complete description, quantity required, method of shipment, shipping address, and billing address.

TRANSITION

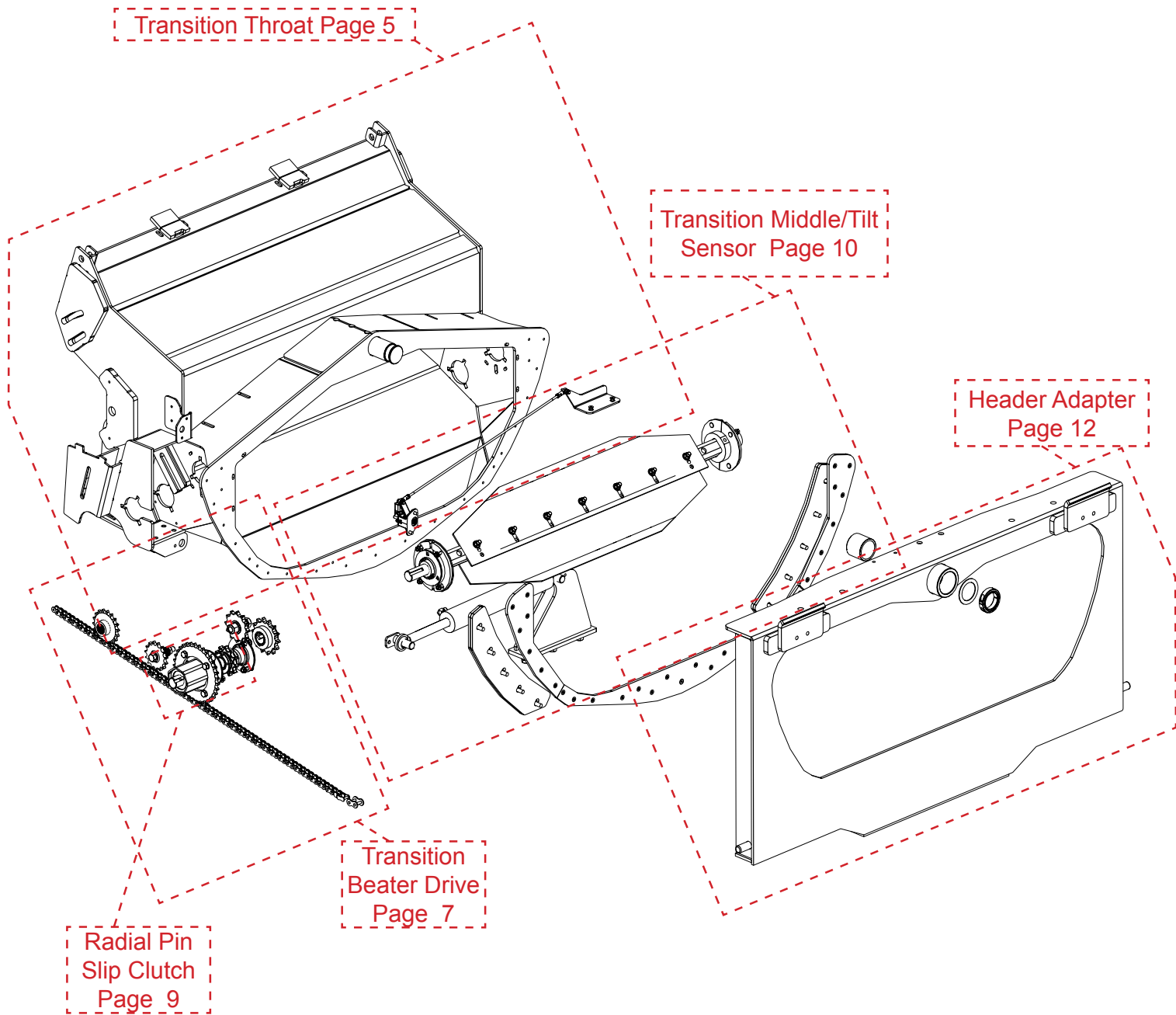

Model JH9010 Hillco Leveling System
For Serial Numbers JH9010-15001 thru JH9010-15999

TRANSITION THROAT

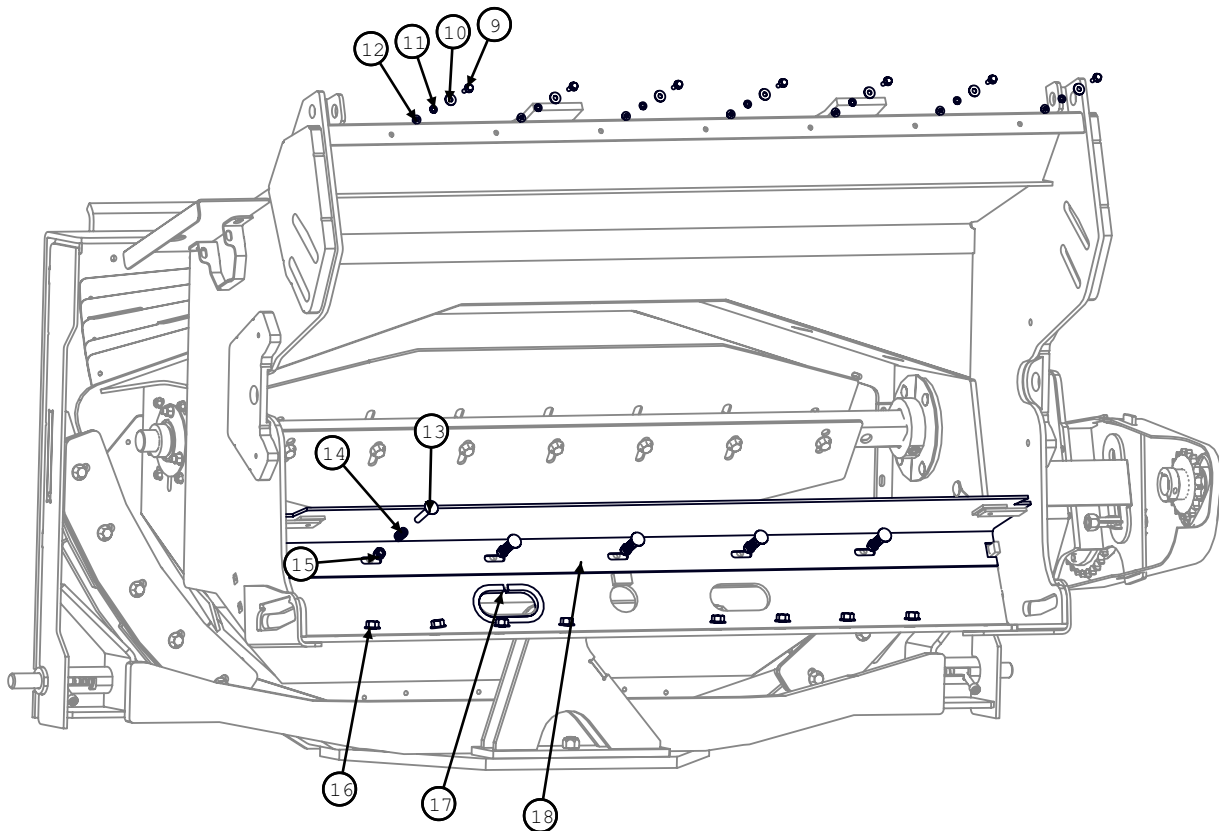
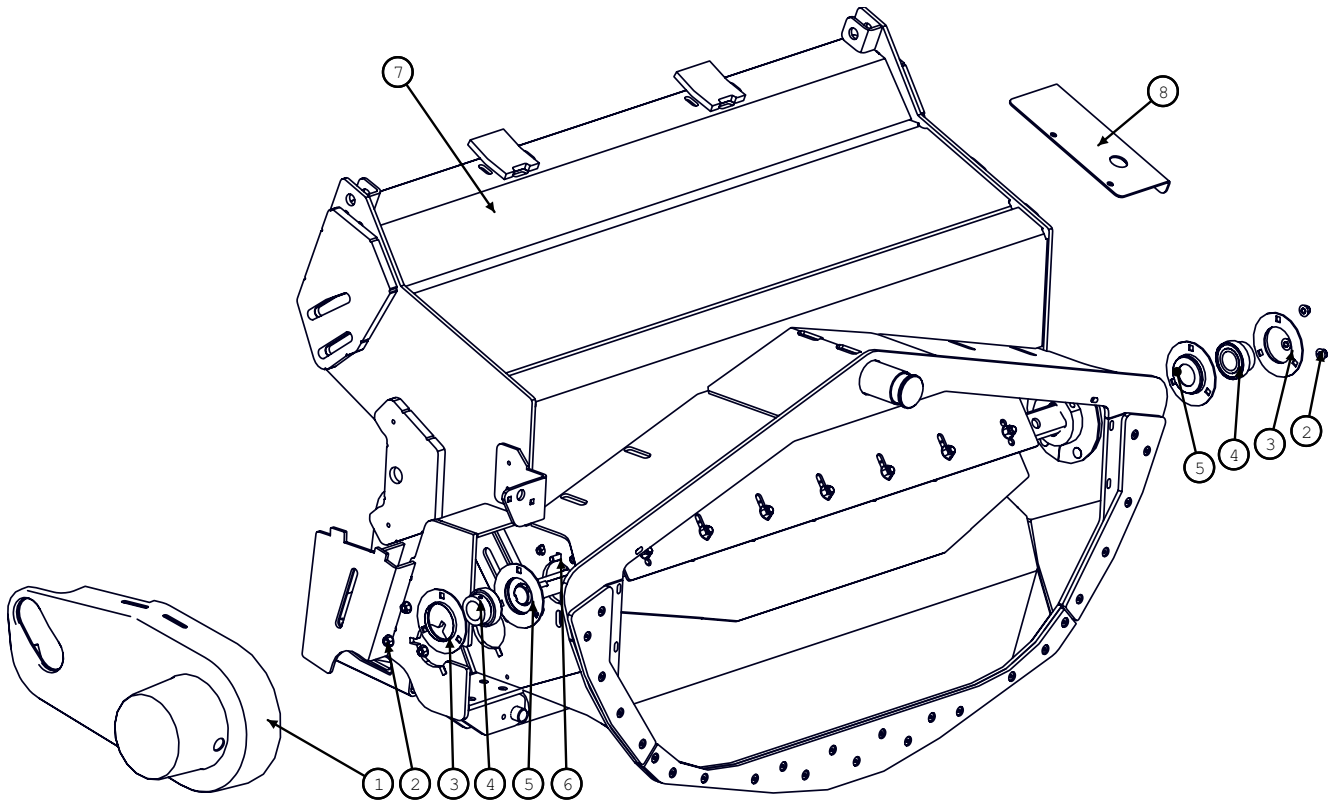

Model JH9010 Hillco Leveling System
For Serial Numbers JH9010-15001 thru JH9010-15999

Transition Throat			
BOM ID	Part No.	Qty	Description
1	1147671	1	SHIELD, BEATER DRIVE
2	123.01	6	NUT,HEX,FLANGE,CL10 M10
3	101339	2	FLANGETTE,
4	100548	2	INSERT BEARING
5	1243691	2	INNER FLANGETTE
6	163.010.030	6	BOLT,CARR,CL8.8 M10
7	1297151	1	THROAT
8	1316461	1	TRIM SHIELD
9	122.006.020	7	BOLT,HX,FL,CL10.9 M6X20
10	105.004	7	WASHER,FLT 1/4
11	136.004	7	WASHER,LCK,MED-SPLIT 1/4
12	123.006	7	NUT,HX,FL,CL10 M6
13	163.010.060	5	BOLT,CARR,CL8.8 M10
14	143591	5	SPRING, COMPRESSION
15	191.01	5	NUT,HX,NYL,CL8 M10
16	123.012	8	NUT,HX,FL,CL10 M12
17	10114.00168	1	TRIM, RUBBER EDGE,
18	1312971	1	FLEX FLOOR

TRANSITION BEATER DRIVE

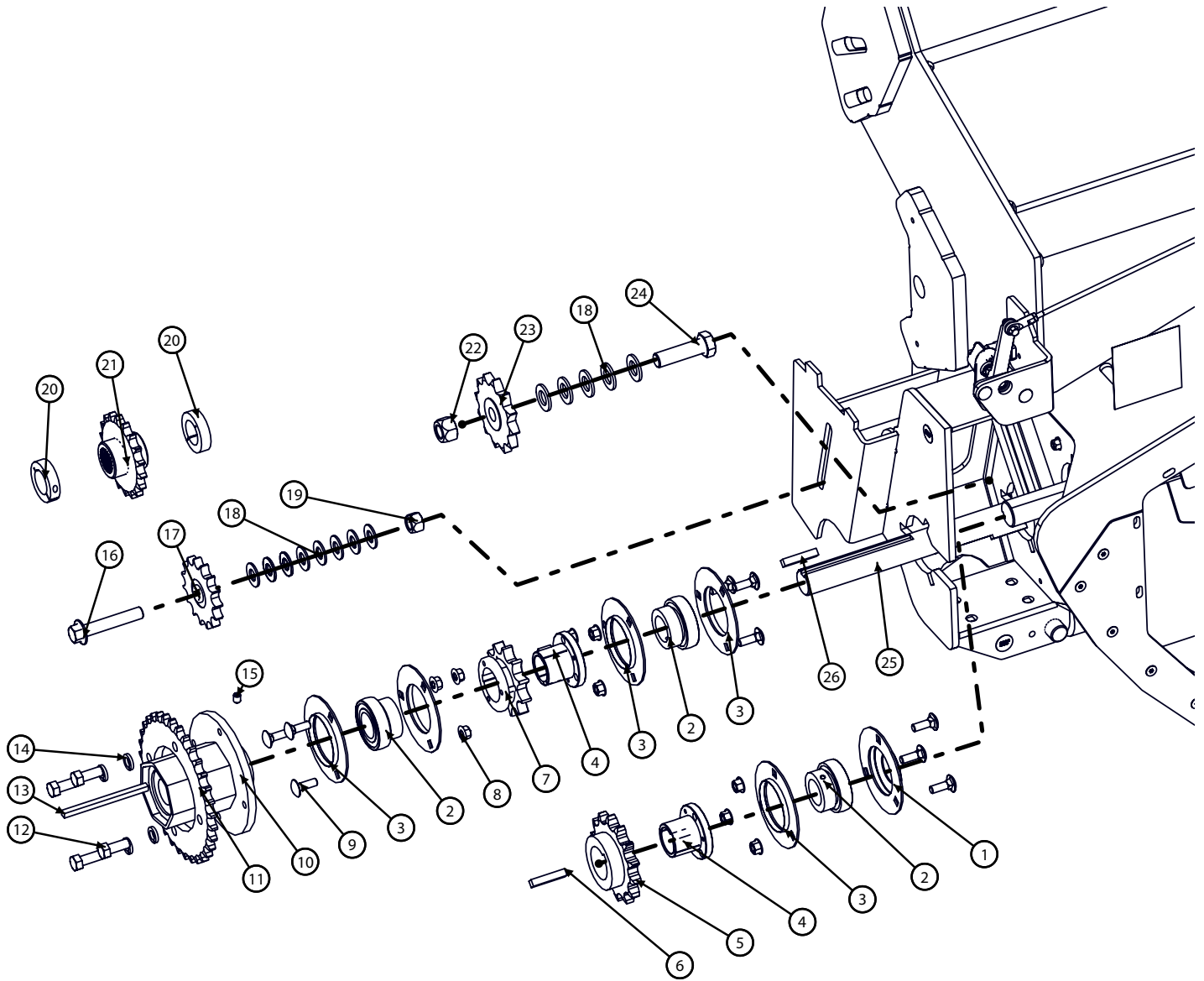

Model JH9010 Hillco Leveling System
For Serial Numbers JH9010-15001 thru JH9010-15999

Transtion Beater Drive			
BOM ID	Part No.	Qty	Description
1	1243691	1	INNER FLANGETTE
2	100548	3	INSERT BEARING
3	101339	5	FLANGETTE,
4	135511	2	HUB, SPLIT TAPER
5	136151	1	SPROCKET, TAPER BORE
6	10049.06.00032	1	SQ,1018,CD 3/8X2
7	135491	1	SPROCKET, TAPER BORE
8	123.01	9	NUT,HX,FL,CL10 M10
9	163.010.030	9	BOLT,CARR,CL8.8 M10
10	136921	1	SLIP CLUTCH, RADIAL
11	1226532	1	SPROCKET, PLATE
12	167.008.020	4	BOLT,HX,GR8 1/2-20X1-1/4
13	10049.05.00080	1	SQ,1018,CD 5/16X5
14	139.008	4	WASHER,LCK,HVY-SPLIT 1/2
15	158.006.008	1	SCREW,SKT,SET 3/8-16X1/2
16	122.016.090	1	BOLT,HX,FL,CL10.9 M16X90
17	100237	1	SPROCKET, IDLER, 60P
18	133.01	15	WASHER,L9,HD
19	126.016	1	NUT,HX,STV,CL10 M16
20	142001	2	1 PC SPLIT COLLAR,
21	1273851	1	DRIVE SPROCKET
22	126.02	1	NUT,HX,STV,CL10 M20
23	137441	1	SPOCKET, IDLER
24	121.020.070	1	BOLT,HX,CL10.9 M20
25	1229142	1	JACK SHAFT, RND, 1144, G&P 1-7/16" X 13-1/16
26	10049.06.00032	1	SQ,1018,CD 3/8X2
DRIVE CHAINS			
NS	10068.073	-	60 PITCH CHAIN, 73 PITCHES, TRANSITION DRIVE
NS	10066.029		80 PITCH CHAIN, 29 PITCHES, PADDLE BEATER DRIVE

RADIAL PIN SLIP CLUTCH

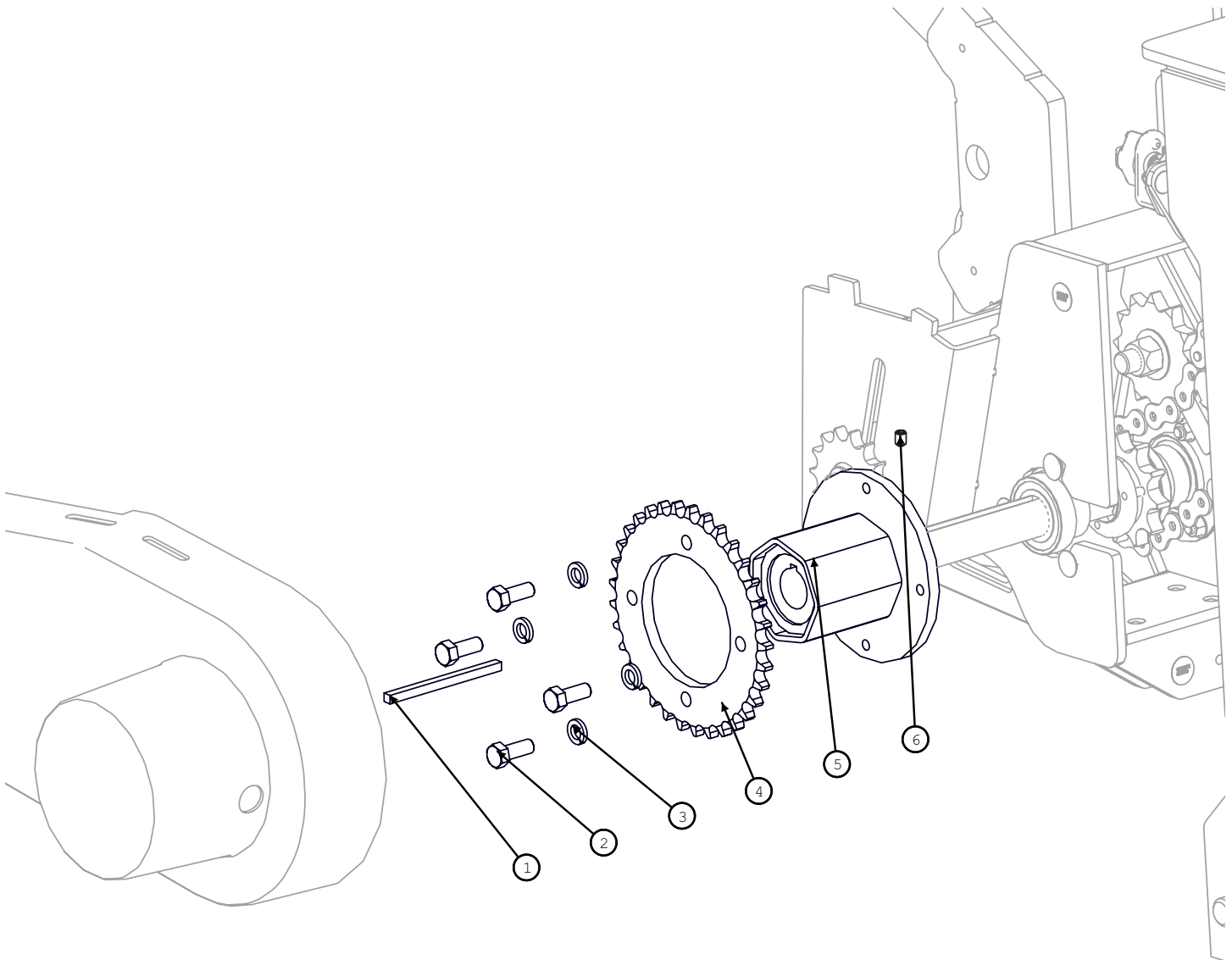

Radial Pin Slip Clutch			
BOM ID	Part No.	Qty	Description
ASM	LA-242431	1	SLIP CLUTCH ASM, RADIAL PIN
1	10049.05.00080	1	SQ,1018,CD 5/16X5
2	167.008.020	4	BOLT,HX,GR8 1/2-20X1-1/4
3	139.008	4	WASHER,LCK,HVY-SPLIT 1/2
4	1226532	1	SPROCKET, PLATE
5	136921	1	SLIP CLUTCH, RADIAL
6	158.006.008	1	SCREW,SKT,SET 3/8-16X1/2

Model JH9010 Hillco Leveling System
For Serial Numbers JH9010-15001 thru JH9010-15999

TRANSITION MIDDLE

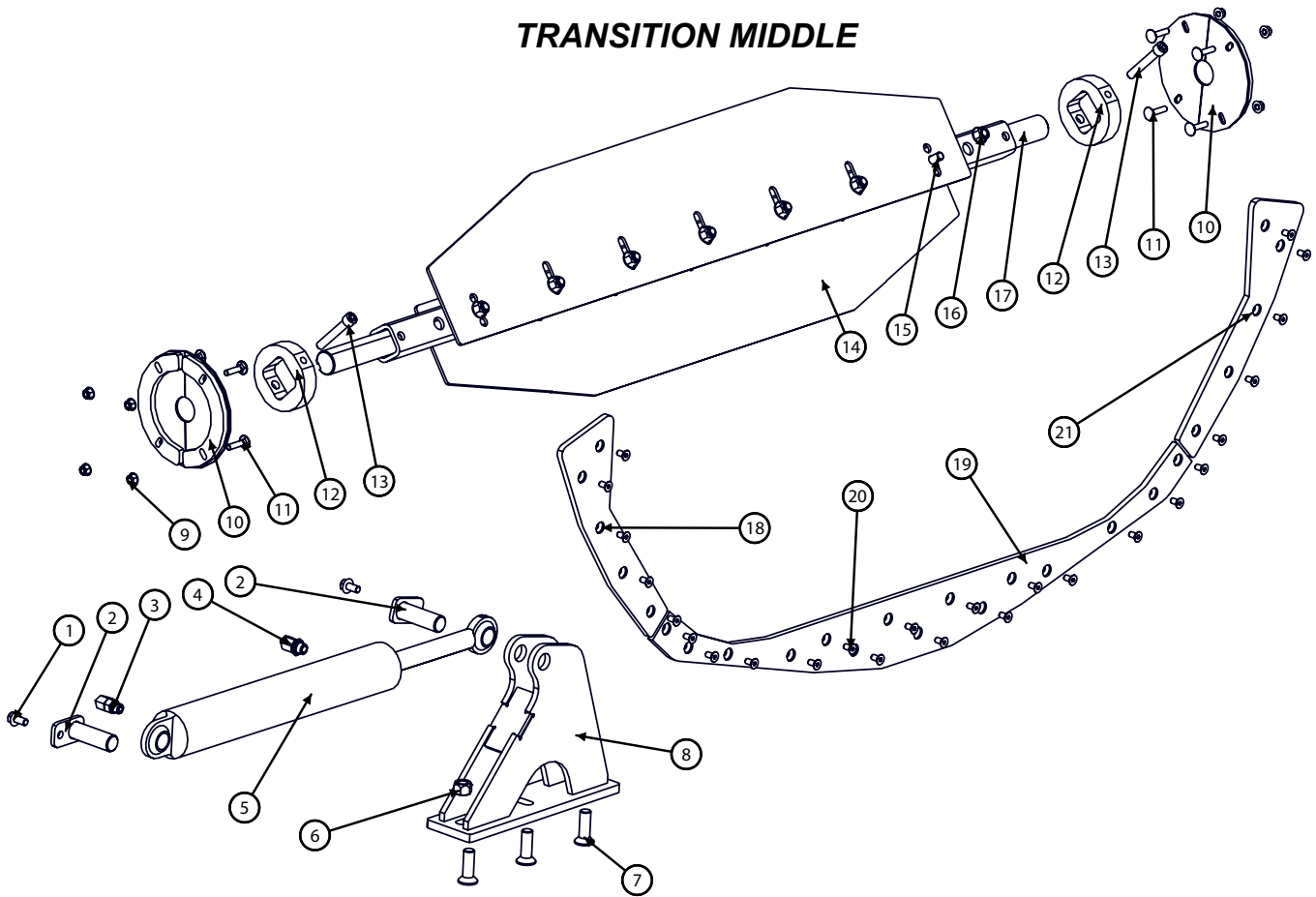

Transition Middle			
BOM ID	HILLCO Part No.	Qty	Description
1	122.010.020	2	BOLT,HX,FL,CL10.9 M10X20
2	1229071	2	CYLINDER PIN, TRIM
3	1003.06.06	1	HA,90° 6MORB X 6MORS 90°
4	1002.06.06	1	HA,45° -6MORB X -6MORFS
5	147491	1	CYLINDER,SLAVE,21"CPC
6	126.016	3	NUT,HX,STV,CL10 M16
7	221.016.050	3	SCREW,COUNTERSUNK,
8	1229023	1	ROD MOUNT
9	128.008	8	NUT,HX,FL,STV,CL10 M8
10	1286311	4	CAN ASM
11	163.008.035	8	BOLT,CARR,CL8.8 M8X35
12	1286331	2	SHAFT SEAL
13	159.012.075	2	SCREW,SHC,CL12.9 M12X75
14	1286321	2	PADDLE,METAL,NARROW
15	122.012.080	7	BOLT,HX,FL,CL10.9 M12X80
16	128.012	7	NUT,HX,FL,STV,CL10 M12
17	1251632	1	BEATER SHAFT
18	1229162	1	SIDE WEAR PLATE, L

Model JH9010 Hillco Leveling System
 For Serial Numbers JH9010-15001 thru JH9010-15999

HEADER POSITION SENSOR

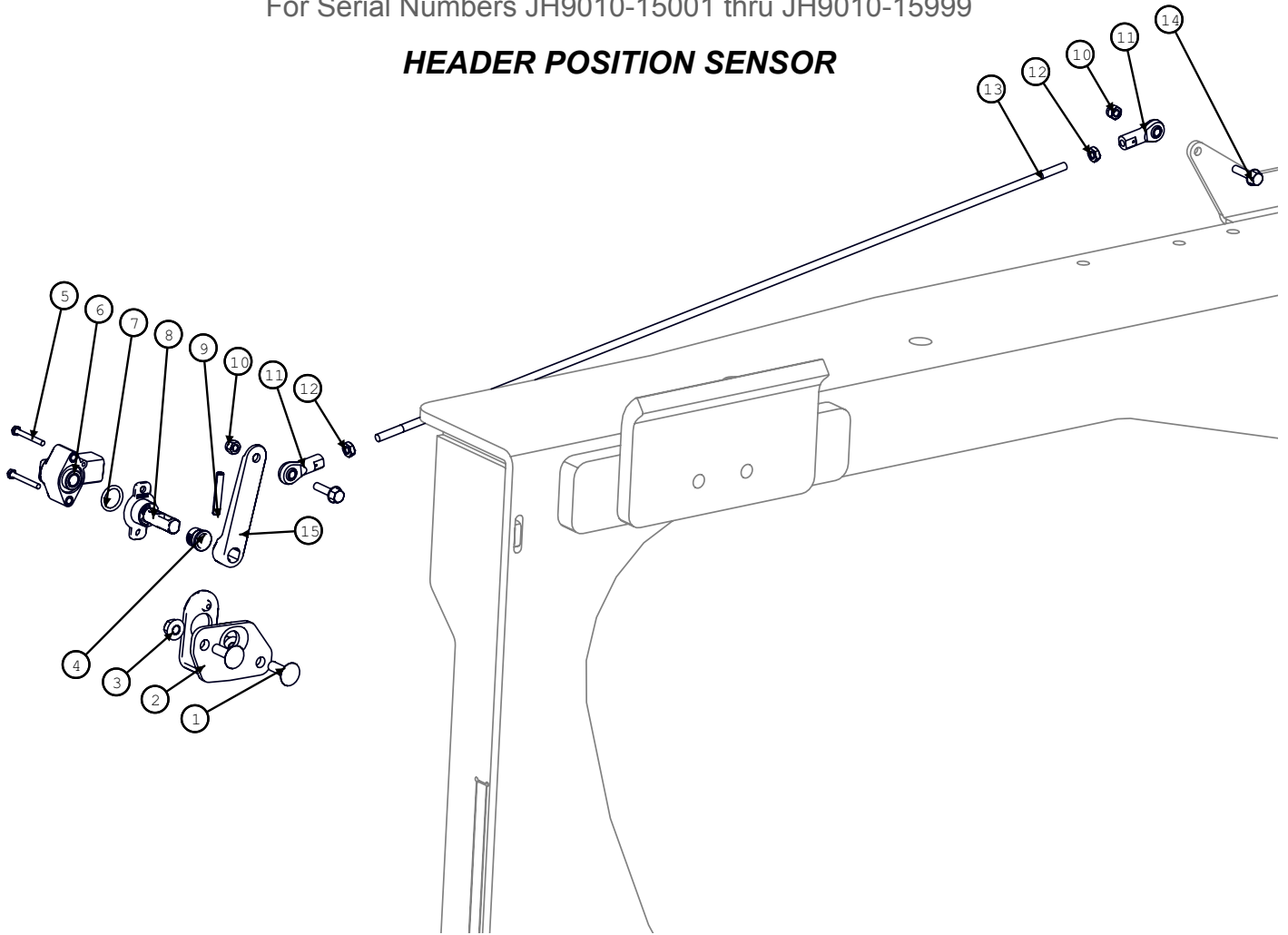

Header Position Sensor			
BOM ID	HILLCO Part No.	Qty	Description
1	163.008.025	2	BOLT,CARR,CL8.8 M8X25
2	151321	1	BRACKET, SENSOR
3	123.008	2	NUT,HX,FL,CL10 M8
4	151361	1	BUSHING,
5	170.004.035	2	BOLT, HX,CL8.8
6	151381	1	SENSOR, ROTATION,
7	151391	1	O-RING, 11/16ID
8	151401	1	SENSOR SHAFT,
9	201.006.036	1	PIN,ROLL M6X36
10	191.006	2	NUT,HX,NYL,CL8 M6
11	151881	2	ROD END, BALL JOINT,
12	174.004	2	NUT,HX,JAM,GR5 1/4-20
13	1295502	1	SENSOR ROD
14	122.006.025	2	BOLT,HX,FL,CL10.9 M6X25

Model JH9010 Hillco Leveling System
 For Serial Numbers JH9010-15001 thru JH9010-15999

TRANSITION HEADER ADAPTER

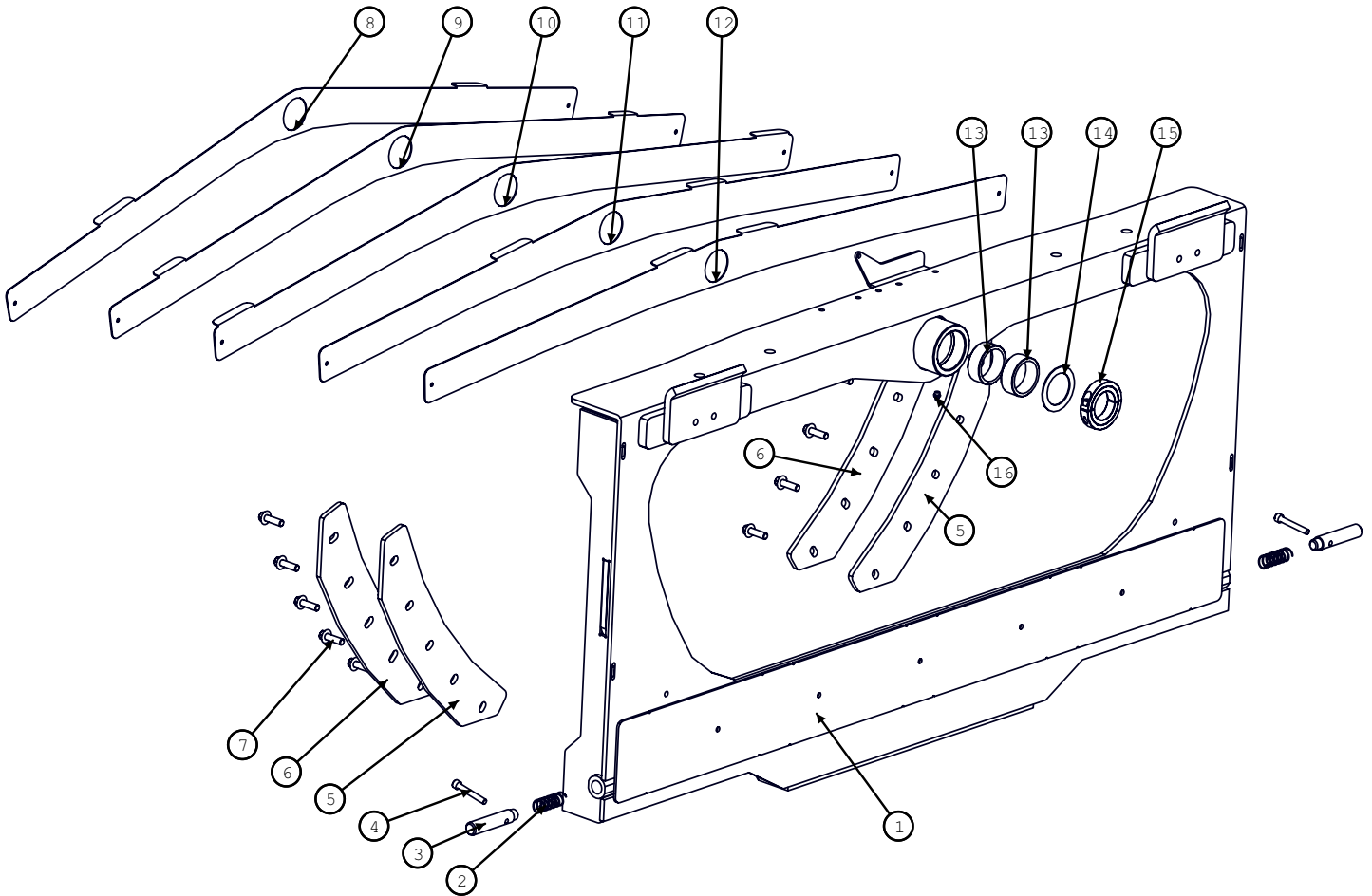

Transition Header Adapter			
BOM ID	Part No.	Qty	Description
1	1306121	1	HEADER ADAPTER
2	135531	2	SPRING, COMPRESSION
3	1229193	2	LOCKOUT PIN
4	159.010.070	2	SCREW, SHC, CL12.9
5	1249871	2	WEAR PLATE,
6	1249861	2	BACKING PLATE
7	122.012.040	10	BOLT,HX,FL,CL10.9 M12X40
8-12	P306131	1	DEFLECTOR KIT
8	1306183	1	DEFLECTOR, REAR
9	1306173	1	DEFLECTOR, INNER REAR
10	1306163	1	DEFLECTOR,
11	1306153	1	DEFLECTOR, INNER FRONT
12	1306143	1	DEFLECTOR, FRONT
13	1305471	2	PIVOT BUSHING
14	162.014.040	1	BUSHING,MACH,NR
15	150742	1	COLLAR,CLAMPING,2-1/2 ID 3-3/4 OD, 2 PIECE HEAVY
16	133891	1	ZERK, GREASE, 1/8

Model JH9010 Hillco Leveling System
For Serial Numbers JH9010-15001 thru JH9010-15999

Carriage

Overcarriage
Page 14

Carriage
Position Sensor
Page 18

Misc.
Carriage
Parts
Page 17

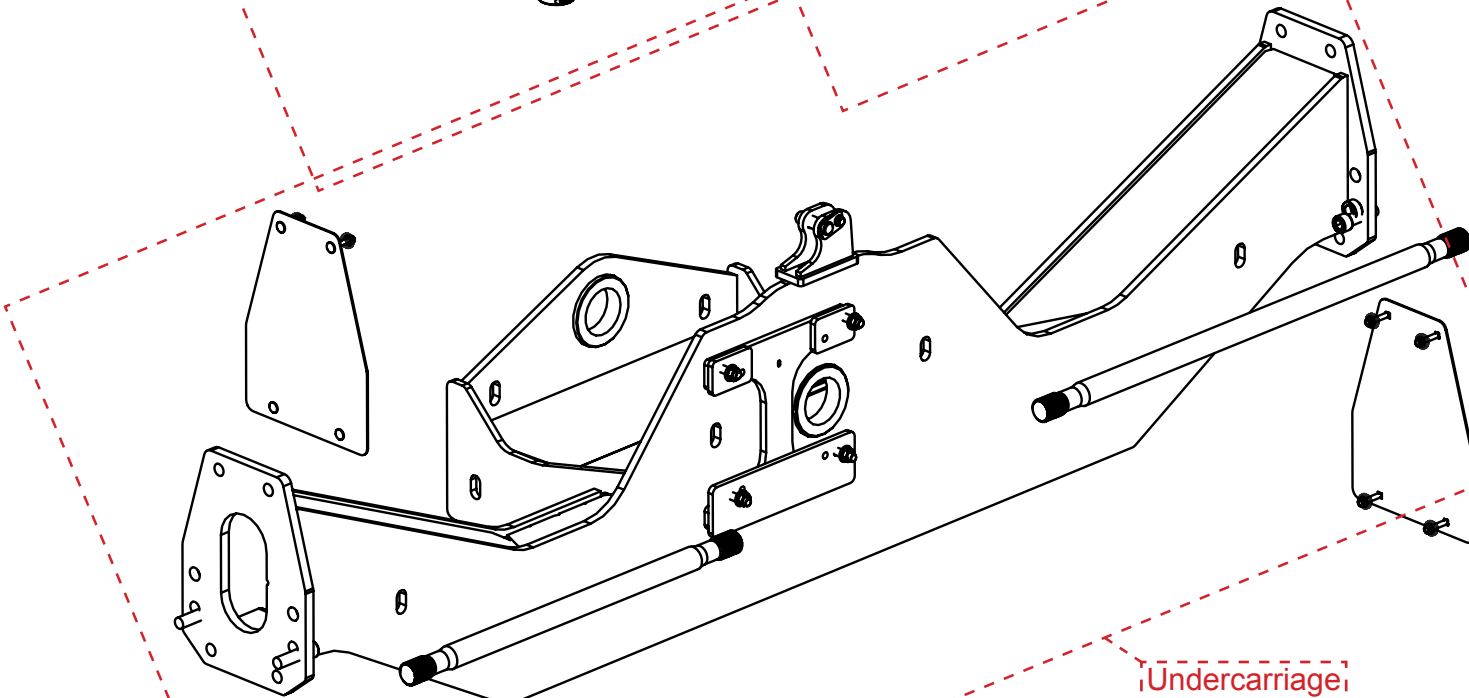
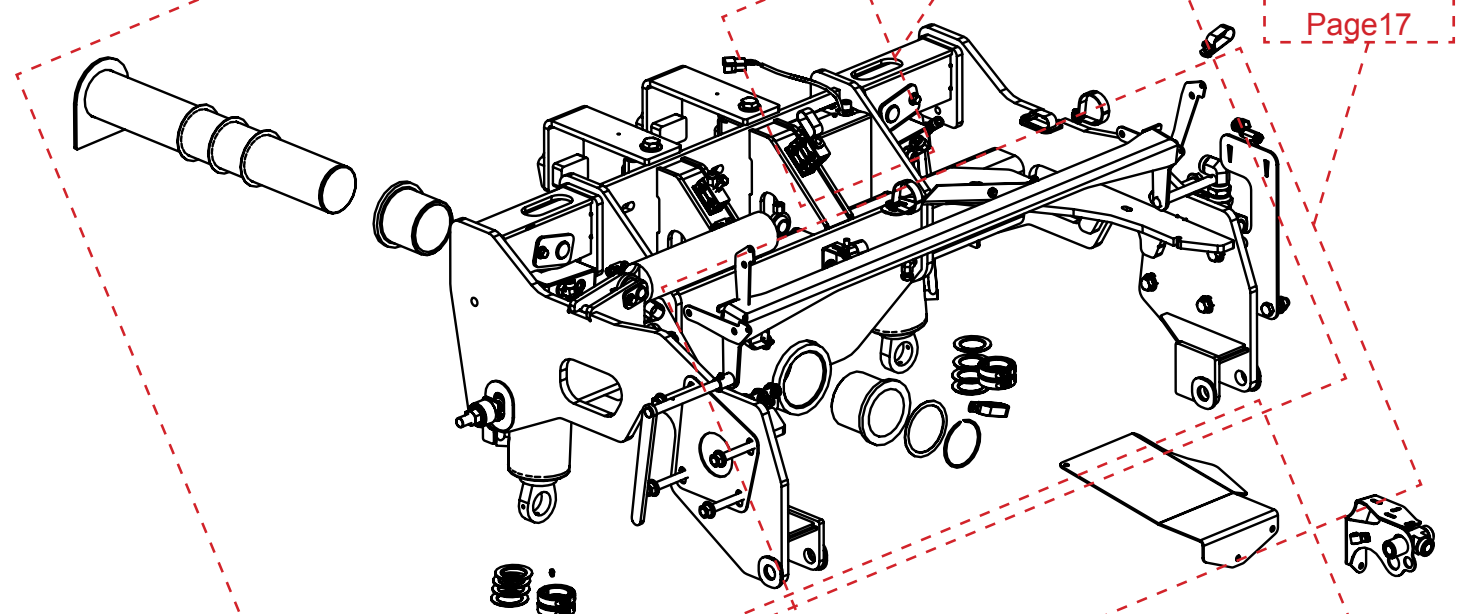

Undercarriage
Page 16

Model JH9010 Hillco Leveling System
For Serial Numbers JH9010-15001 thru JH9010-15999

Overcarriage

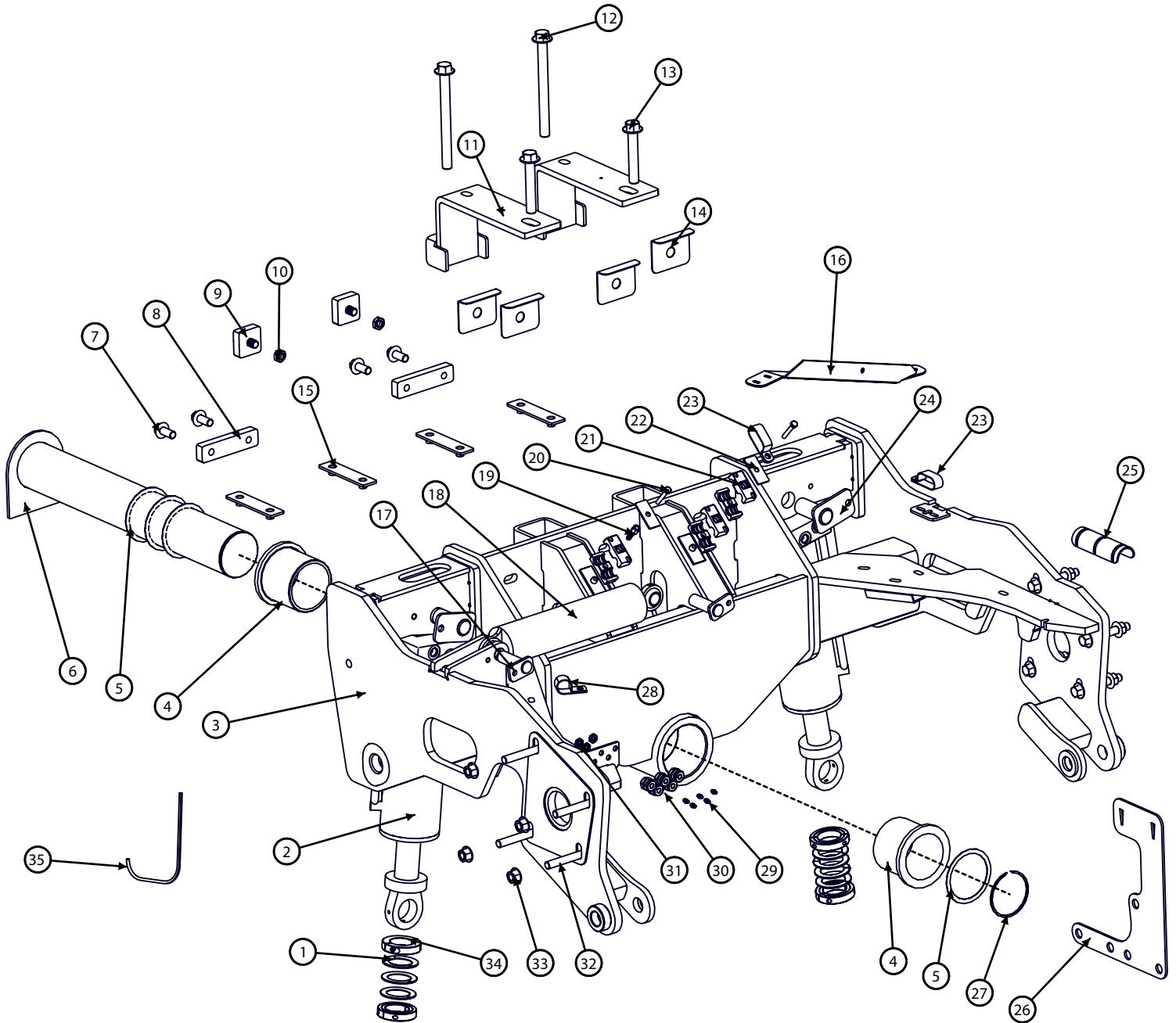

Model JH9010 Hillco Leveling System
For Serial Numbers JH9010-15001 thru JH9010-15999

Overcarriage			
BOM ID	Part No.	Qty	Description
1	137501	8	WASHER, QUICK REPAIR
2	151002	2	CYLINDER, CB VALVE,
3	1291332	1	OVERCARRIAGE
4	1247961	2	PIVOT BUSHING
5	138641	4	WASHER; 4.016ID X
6	1291351	1	PIVOT PIN
7	122.016.035	4	BOLT,HX,FL,CL10.9 M16X35
8	1291731	2	CARRIAGE LOCK
9	1293581	2	UPPER CARRIAGE SHIM
10	165.016	2	NUT,HX,JAM,CL8 M16
11	1293631	2	AXLE CLAMP
12	122.020.220	2	BOLT,HX,FL,CL10.9 M20
13	122.020.120	2	BOLT,HX,FL,CL10.9 M20
14	1270042	4	CARRIAGE SHIM
15	1293561	4	LOWER CARRIAGE SHIM
16	1274901	1	SUPPORT, HYDRO HOSE
17	1229071	2	CYLINDER PIN, TRIM
18	140342	1	CYLINDER, CROSS PORT
19	139471	1	STACK BOLT, BEHRINGER
20	101.005.032	2	BOLT,HX,GR5 5/16-18X2
21	139431	3	CLAMP, 3/4" TWIN BEHRINGER PAIR
22	139451	2	COVER PLATE,TWIN
23	147781	2	CLAMP, DOUBLE LOOP
24	1230552	2	PIN, MAIN CYLINDER
25	155254	1	HOSE PROTECTOR, 2.5W X 6"
26	1297821	1	MANIFOLD SPACER
27	138651	1	SNAP RING; 4"
28	151311	1	CLAMP, RC 1-1/4"
29	138011	5	ZERK,STR, 1/4-28MTAPER
30	155157	5	BULKHEAD,GREASE,STR,
31	155158	5	BULKHEAD,LOCKNUT
32	122.016.110	8	BOLT,HX,FL,CL10.9 M16X110
33	123.016	8	NUT,HX,FL,CL10 M16
34	153241	4	COLLAR, CLAMPING
35	10130.00096	1	VINYL EDGE TRIM AROUND HYDRAULIC HOSES

Model JH9010 Hillco Leveling System
For Serial Numbers JH9010-15001 thru JH9010-15999

Undercarriage

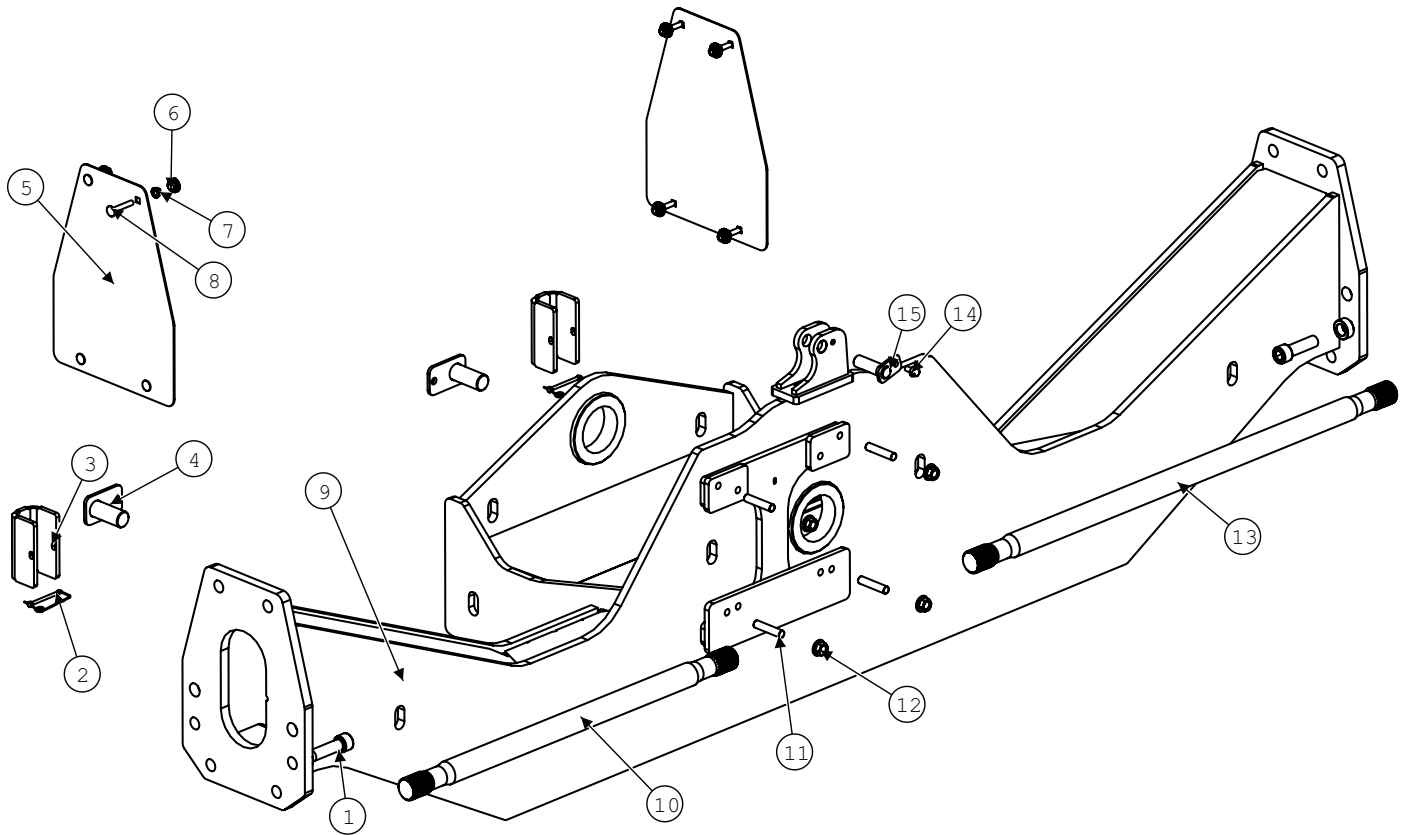

Undercarriage			
BOM ID	Part No.	Qty	Description
1	159.024.080	4	SHCS 12.9-M24 X 3 X 80 PLT
2	146.004.048	2	SNAP LOCK PIN 1/4 X 3
3	1306721	2	CM PLT, CYLINDER STOP
4	1230552	2	CM PIN ASM, MAIN CYLINDER
5	1293831	2	CM SHT, CAP, AXLE
6	151021	8	BUSHING, PLASTIC (JD#Z31550)
7	123.010	8	FLHN-10.9 M10 X 1.50
8	163.010.050	8	CARR-8.8M10X1.5X50 HEAD SCREW
9	1291431	1	CU WLD, UNDERCARRIAGE, 122.5
10	151531	1	SHAFT, DRIVE 951MM
11	155.016	4	STUD, DOUBLE-10.9 M16X2.00X75
12	F-HNF-16ME	4	FLHN-10.9M16X2.0
13	151541	1	SHAFT, DRIVE 1228MM
14	122.010.020	1	BOLT,HX,FL,CL10.9 M10X20
15	1229071	1	CYLINDER PIN, TRIM

Model JH9010 Hillco Leveling System
For Serial Numbers JH9010-15001 thru JH9010-15999

Carriage Misc. Parts

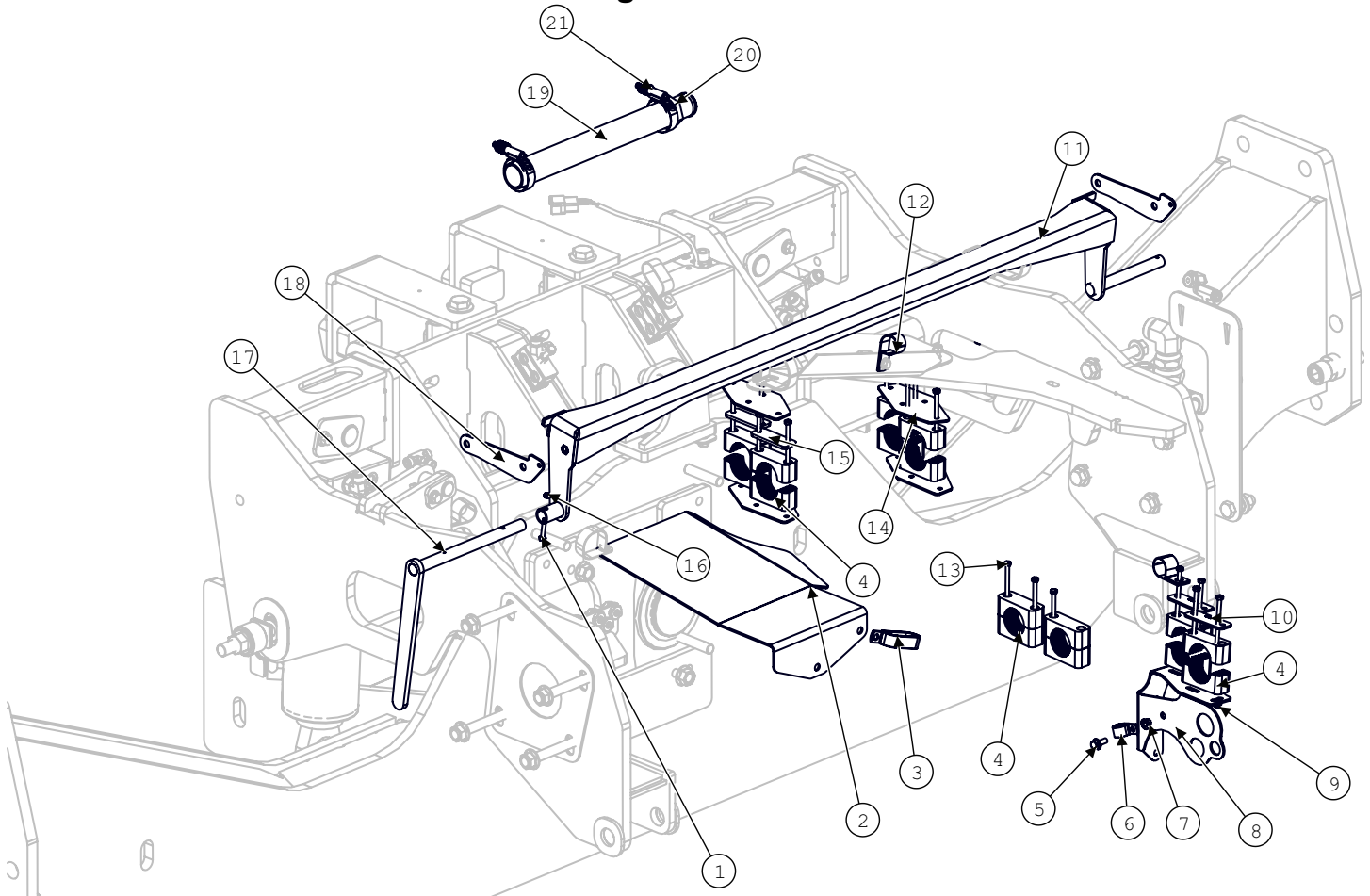

Overcarriage Misc.			
BOM ID	Part No.	Qty	Description
1	121.006.035	1	HC-10.9 M6x1.0X35
2	1274252	1	HM PLT, TABLE HYDRO HOSE
3	1151781	1	CLAMP, P-STYLE (JD#AH77884)
4	140641	8	CLAMP, 2" BEHRINGER STD
5	179.008.025	1	FLHC-10.9M8X1.25X20
6	135791	1	CLAMP, HOSE 7/8 R/C W 3/8HOLE (JD#AH78237)
7	123.008	1	FLHN-10.9M8X1.25
8	1297312	1	LM WLD, HYDRO HOSE SUPPORT
9	F-HNF-06ME	4	FLHN-10.9M6X1.00
10	140651	2	BEHRINGER STD COVER PLATE
11	1264511	1	LM ASM, LINKAGE, ROCK TRAP
12	143601	2	CLAMP, HOSE 1-1/8" R/C W 3/8
13	170.006.090	15	HC-8.8 M6 X 1.00 X 90
14	1274231	4	HM PLT, HYDRO HOSE SUPPORT
15	1276391	2	HM CLAMP SPACER
16	191.006	1	HN-8.8M6X1.0 NYLOCK
17	1264501	1	LM ASM, HANDLE, ROCK TRAP
18	1290741	2	LM SHT, ROCK TRAP LINKAGE, UPPER
19	1276351	1	HOSE, 1-1/2" BELLOWSFLEX HARDWALL 14"
20	1063.24.24	1	UNION, -24MB x -24MB
21	152061	2	CLAMP, HOSE, WORM GEAR, 1.5" TO 2.5"

Carriage Position Sensor

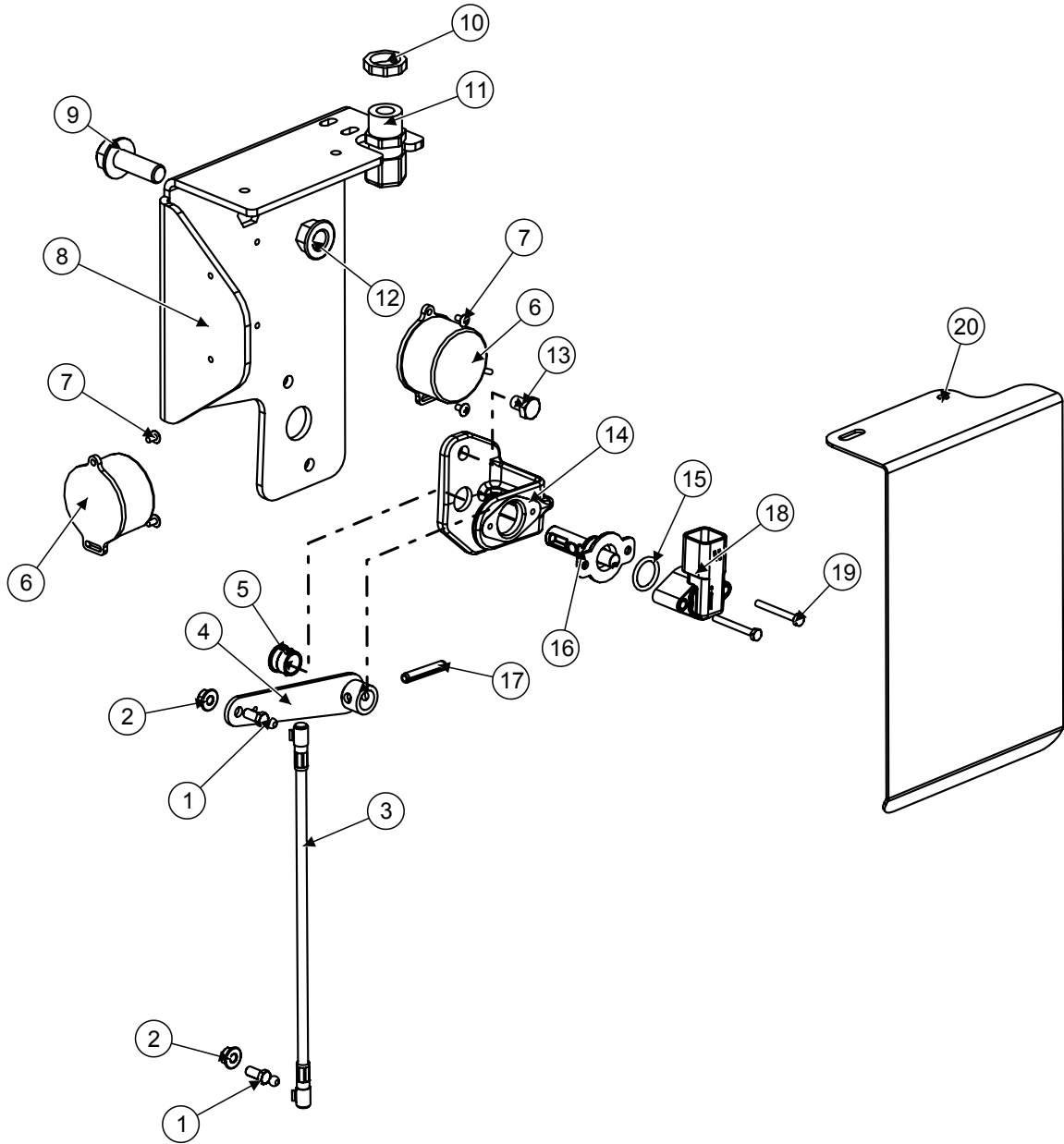

Model JH9010 Hillco Leveling System
For Serial Numbers JH9010-15001 thru JH9010-15999

Carriage Position Sensor				
BOM ID	Hillco Part No.	John Deere Part No.	Qty	Description
1	151341	H168732	2	BALL STUD (H168732)
2	123.006	-	2	FLHN-10.9M6X1.00
3	151331	AH226146	1	LINKAGE, POSITION (AH226146)
4	151371	AXE17303	1	ARM, ASSY, TILT SENSOR, HM (axe17303)
5	151361	R41076	1	BUSHING, (R41076)
6	141841	-	2	EM ASM, CLINOMETER (Only 1 used on Sidehill's)
7	115.#06.004	-	4	PHMS #6-32X1/4
8	1295142	-	1	EM SHT, SENSOR MNT, CLINOMETER
9	122.012.035	-	1	FLHC 10.9 M12 X 1.75 X 35 PLT
10	142121	-	1	STRAIN RELIEF NUT, 1/2" BLACK
11	138781	-	1	STRAIN RELIEF, NYLON, BLK,
12	123.012	-	1	FLHN-10.9 M12 x 1.75 PLT
13	170.008.010	19m7008	2	HC-8.8M8X1.25X10 (19m7008)
14	151321	HXE16001	1	BRACKET, SENSOR MNT (HXE16001)
15	151391	P48347	1	O-RING, 11/16ID (P48347)
16	151401	AXE14888	1	SHAFT, ROUGH SERVICE DEVICE (AXE14888)
17	201.006.036	-	1	PIN, ROLL 6mm x 36mm
18	151381	AXE14246	1	SENSOR, ROTATION, HALL 2CH +/-120DE (axe14246)
19	170.004.035	19M9368	2	HC-8.8M4X0.7X035 (19m9368)
20	1303151	-	1	EM SHT, SHIELD SENSOR

DRIVE WHEEL

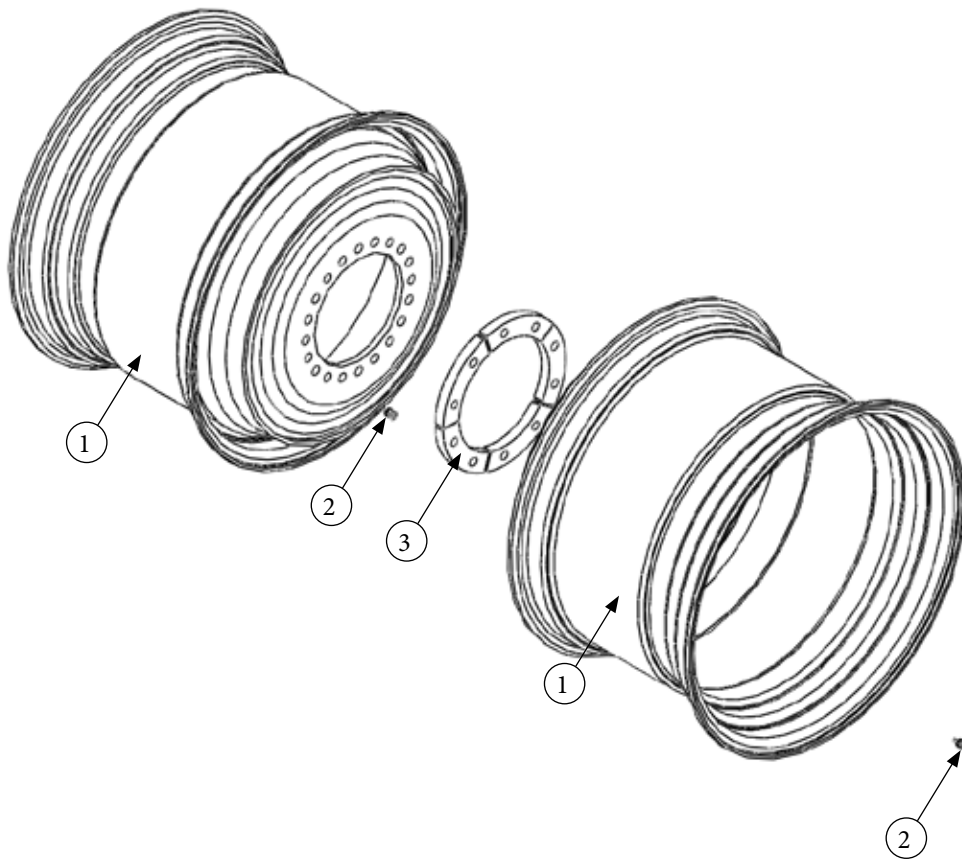

DRIVE WHEEL COMPONENTS				
REF.	PART NO.	QTY.	PART NAME	NOTES
1	MC-143131	4	32 X 21 SINGLE PIECE WHEEL	
2	MC-143921	4	VALVE STEM	
ASM	LA-265961	2	SET, WHEEL CLAMPING RING ASSEMBLY	1 SET PER SIDE
3	LP-260112	10	RING, WHEEL CLAMPING	5 PER SET
STEER WHEEL COMPONENTS				
NS	JD PART NO AXE10349		4 WD REAR WHEEL	JOHN DEERE SUPPLIED PART
NS	JD PART NO AT25226		REAR WHEEL VALVE STEM	JOHN DEERE SUPPLIED PART

Model JH9010 Hillco Leveling System
For Serial Numbers JH9010-15001 thru JH9010-15999

DROP AXLE

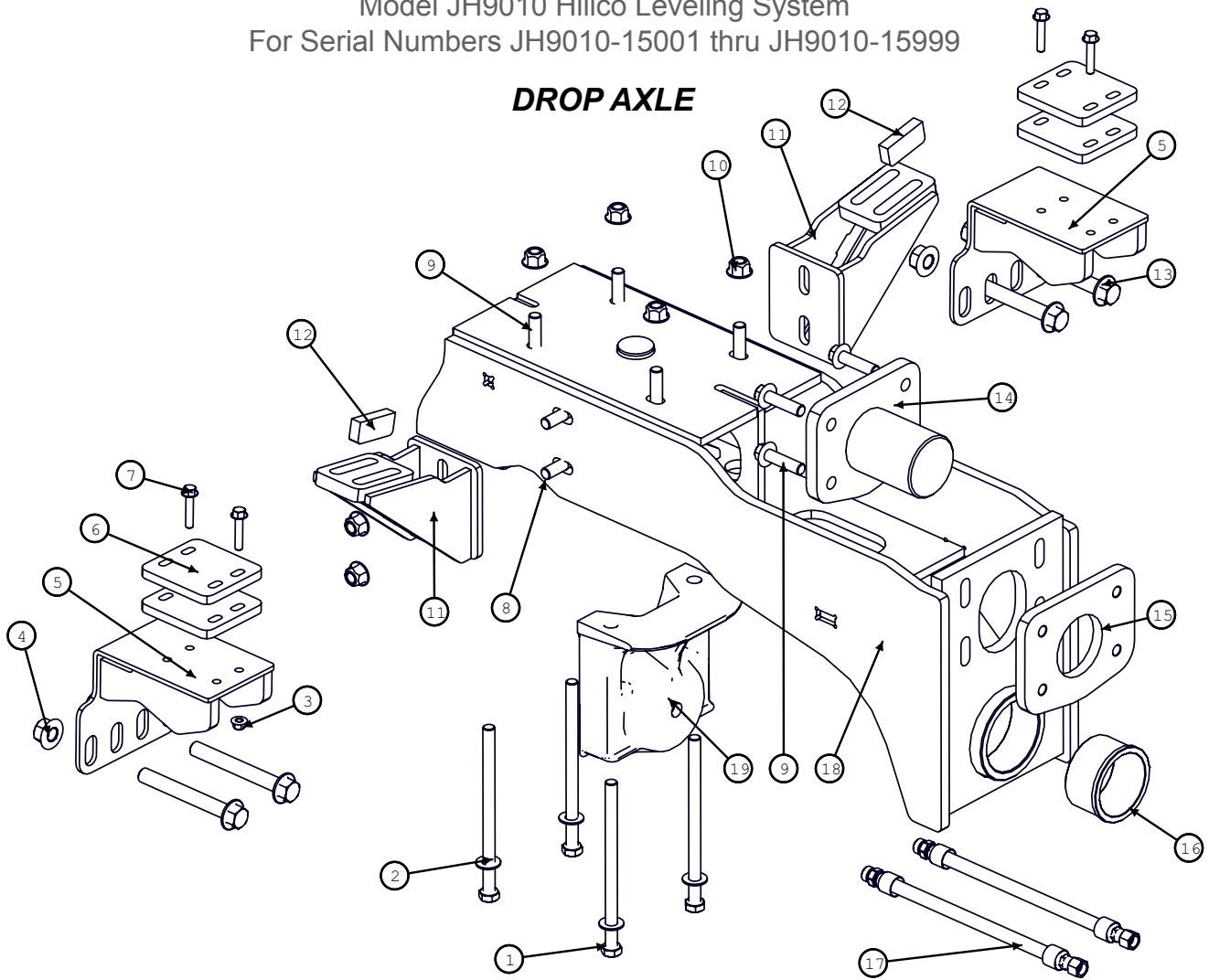

Drop Axle			
BOM ID	Part No.	Qty	Description
1	121.016.250	4	BOLT,HX,CL10.9 M16X250
2	133.01	4	WASHER,L9,HD 5/8
3	128.01	4	NUT,HX,FL,STV,CL10 M10
4	123.02	4	NUT,HX,FL,CL10 M20
5	1299792	2	ROTATION STOP
6	1299892	4	ROTATION STOP 16°
7	122.010.050	4	BOLT,HX,FL,CL10.9 M10X50
8	198.016.050	4	BOLT,CARR,CL10.9 M16X50
9	122.016.060	8	BOLT, HX, FL, CL10.9, M16X60
10	128.016	12	NUT,HX,FL,STV,CL10 M16
11	1313541	2	WING
12	1313571	2	WING STOP
13	122.020.160	4	BOLT,HX,FL,CL10.9 M20
14	1291071	1	PIVOT PIN
15	1291091	1	PIVOT LOCK
16	1235092	1	BUSHING, PIVOT
17	1273461	2	3/8" R2 #8FF#8MF 15"
18	1291022	1	DROP AXLE
19	1299801	1	STAND-OFF, REAR AXLE

Model JH9010 Hillco Leveling System
For Serial Numbers JH9010-15001 thru JH9010-15999

Hydraulic Components

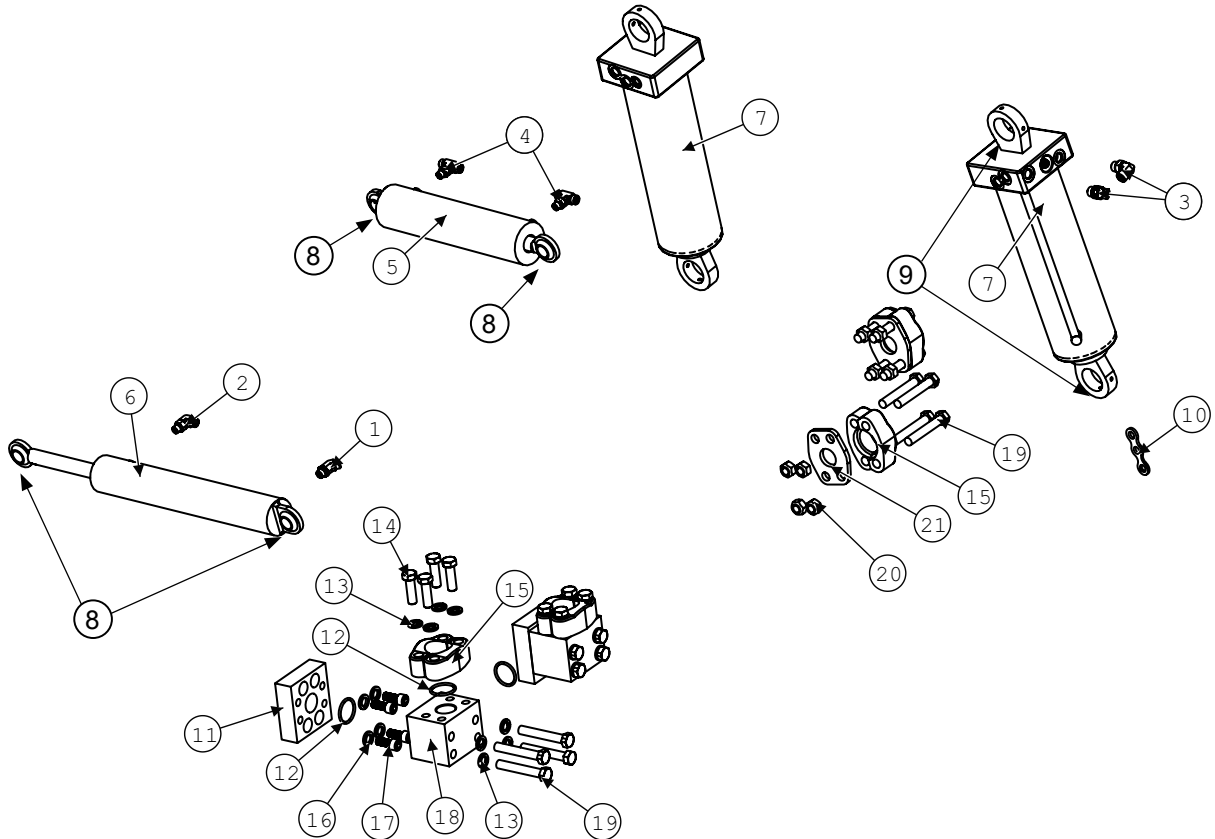

Hydraulic Components			
BOM ID	Part No.	Qty	Description
1	1001.06.06	2	#6 MORS X #6 MORB 45 DEG
2	1003.06.06	2	ELBOW, 90°, 6MF x 6MO
3	1003.08.08	3	ELBOW, 90°, #8MORS#8MORB
4	1009.06	5	TEE, STRAIGHT THREAD, BRANCH -6MF x -6MO
5	140342	2	MASTER CYLINDER, 3"B, 8-3/4"S,1-3/8"R, 17-1/4"CPC, CROSS
NS	HC-134201	-	SEAL KIT, MASTER CYLINDER
6	138582	4	SLAVE CYLINDER, 2-1/2 B, 1-1/8" R, 12-1/2" S, 21" CPC
NS	HC-141281	-	SEAL KIT, SLAVE CYLINDER
7	151002	2	LEVELING CYLINDER, 4-1/2"B,11"S,2"R, 22-1/2 CPC
NS	HC-135221	-	SEAL KIT, LEVELING CYLINDER
8	MC-140321	4	1" BEARING, SEALED SPHERICAL
9	MC-150881	4	1 3/8" BEARING, SEALED SPHERICAL
10	LP-274391	1	LM PLT, HYDRO HOSE SPACER
11	LM-272092	2	CODE 62 90° 1-1/4 ROTATIONAL ADAPTER
12	147621	8	O-RING, CODE 62, 1-1/4"
13	139.009	16	LW 9/16 HD
14	121.014.045	8	HC-10.9M14 X2.0X45
15	147611	8	FLANGE, 1-1/4" CODE 62, HALF
16	135.009	8	LW 9/16 HD HIGH COLLAR
17	159.014.030	8	SHCS-12.9M14X2.0X30
18	LM-272082	2	HM BLOCK, CODE 62 1-1/4 90°
19	121.014.090	16	HC-10.9 M14X2.0X90
20	126.014	8	HN-10.9M14X2.0 STVR
21	1272161	2	HM PLT, CODE 62 1-1/4 UNION

Leveling Manifold

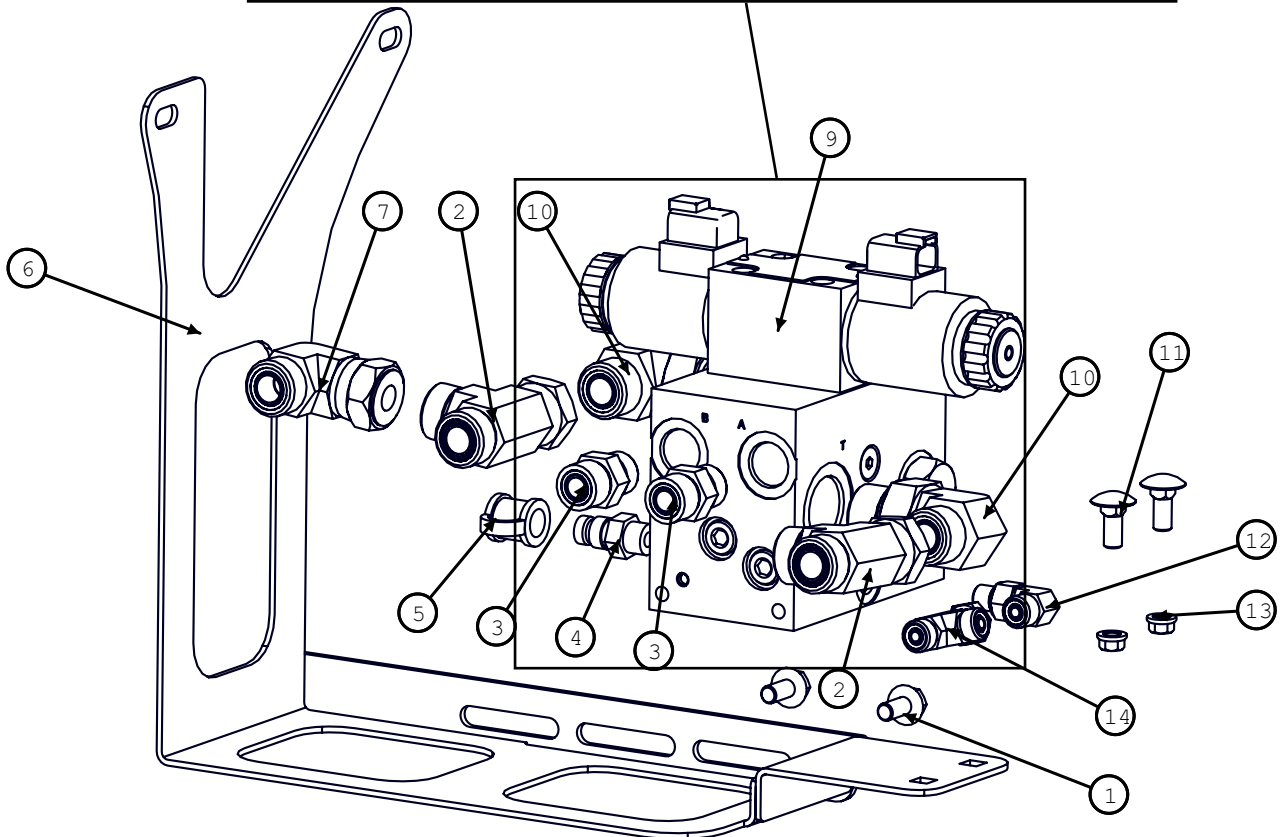
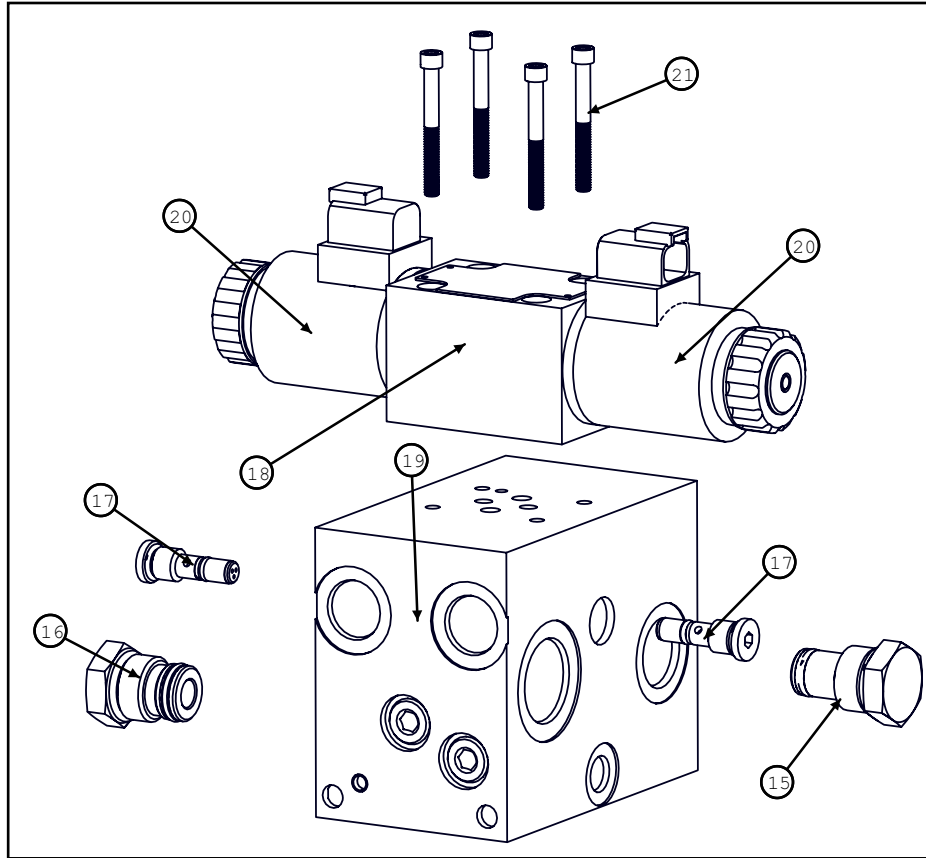

Model JH9010 Hillco Leveling System
For Serial Numbers JH9010-15001 thru JH9010-15999

Leveling Manifold			
BOM ID	Part No.	Qty	Description
1	111.005.010	2	BOLT,HX,FL,GR5 5/16-18X5/8
2	1008.1	2	HA,TEE,SWV,NUT,RUN
3	1001.08.08	2	HA,STR
4	143991	1	COUPLER,
5	144001	1	DUST COVER
6	1313601	1	MANIFOLD MOUNT
7	1006.10.10	1	HA,90°
9	1312741	1	MANIFOLD, CUSTOM, LEV
10	1003.12.10	2	HA,90°
11	163.008.020	2	BOLT,CARR,CL8.8 M8X20
12	1003.04.04	1	HA,90°
13	119.005	2	NUT,HX,FL,SERR 5/16-18
14	1008.04	1	SWV,NUT,RUN -4ORFS
15	155238	1	CAVITY PLUG, 2 WAY, 10 SERIES
16	155234	1	CAVITY PLUG, 3 WAY, 10 SERIES
17	155236	2	CHECK VALVE, REVERSE DIRECTION
18	155237	1	DIRECTIONAL VALVE,PROPORTIONAL (INCLUDES 155239)
19	155235	1	VALVE BODY, LEVELING
20	155239	2	SOLENOID COIL,D03,PROP,DEUTSCH
21	196.#10.028	4	SHCS 10-24 X 1.75

Model JH9010 Hillco Leveling System
For Serial Numbers JH9010-15001 thru JH9010-15999

Header Trim Manifold

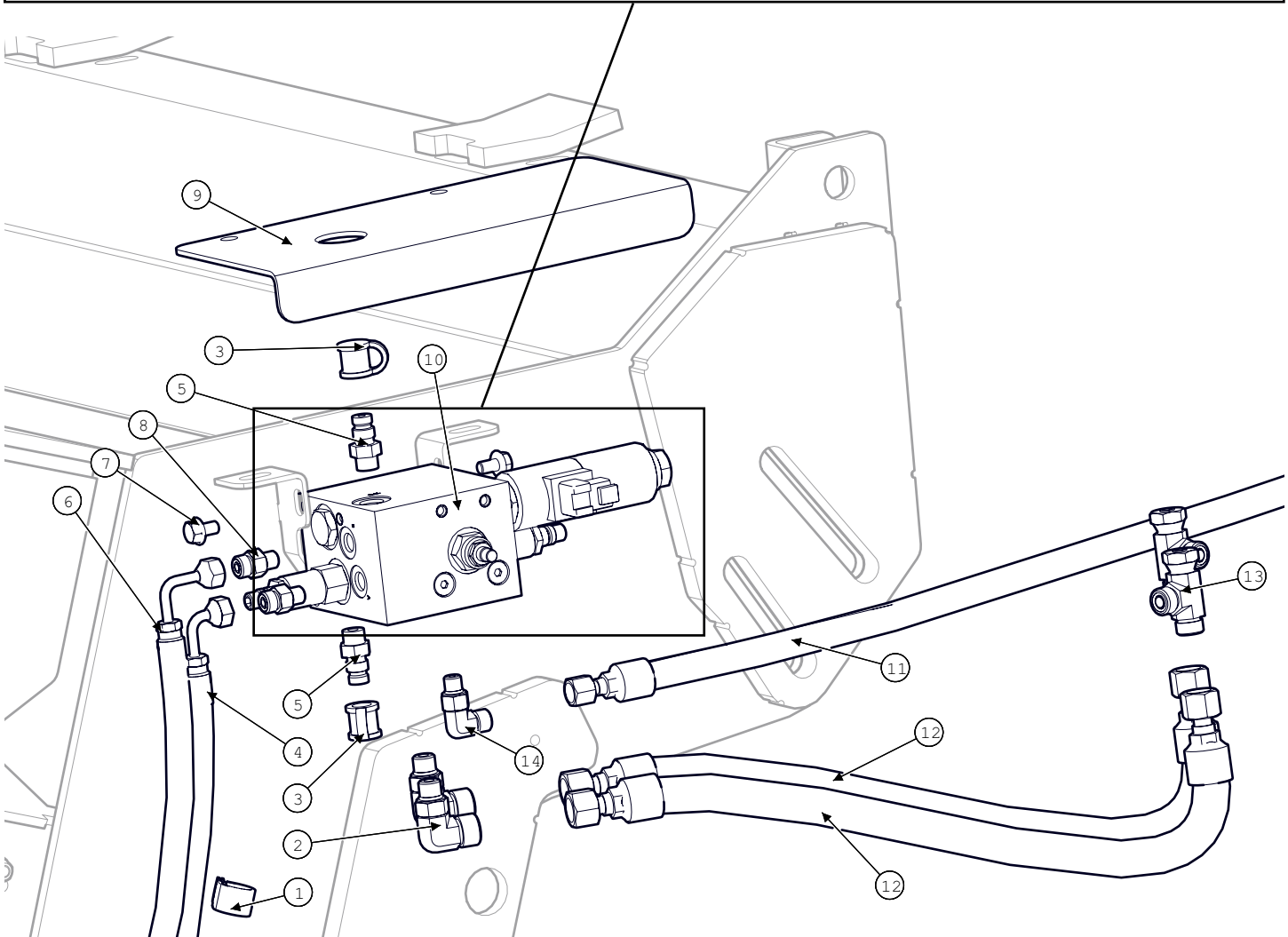
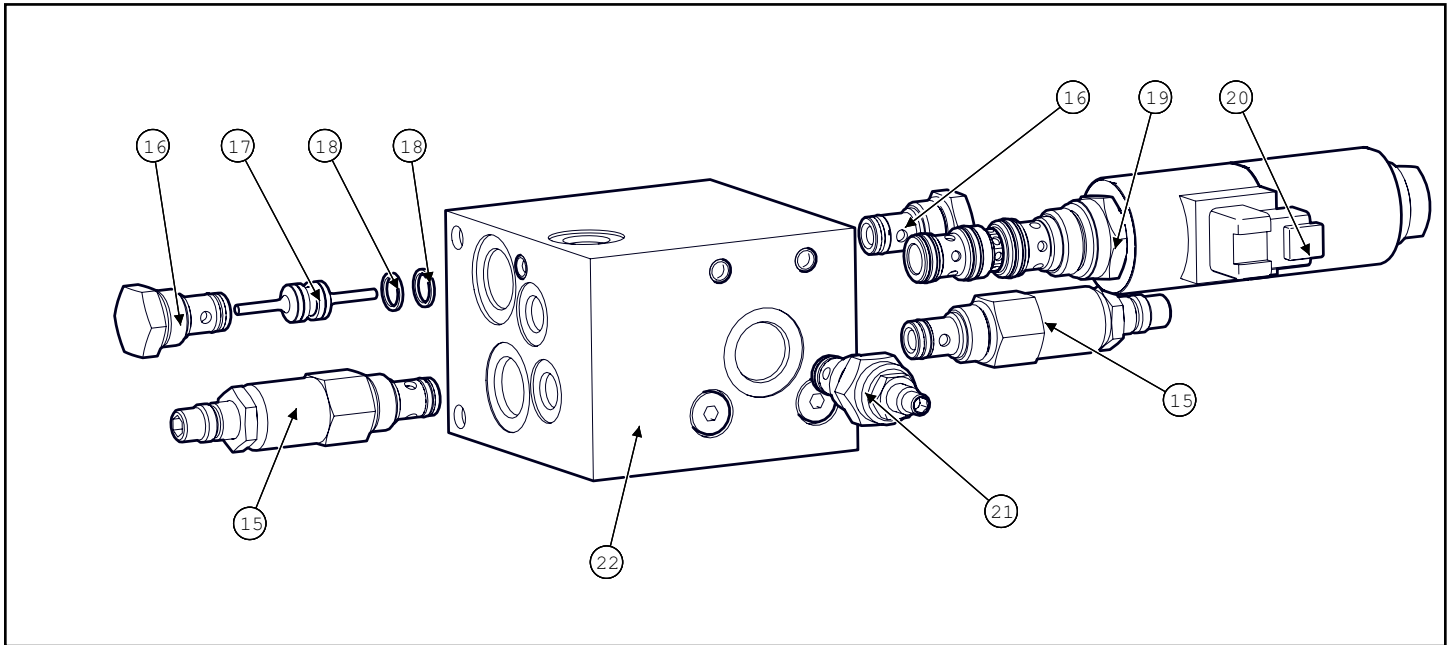

Model JH9010 Hillco Leveling System
For Serial Numbers JH9010-15001 thru JH9010-15999

Header Trim Manifold			
BOM ID	Part No.	Qty	Description
1	135791	2	CLAMP, HOSE
2	1003.08.06	2	-8MORB X -6MORFS
3	144001	2	DUST COVER
4	1322112	1	100R17-04 67",
5	143991	2	COUPLER,
6	1322101	1	100R17-04X80",
7	111.005.008	2	BOLT,HX,FL,GR5 5/16-18X1/2
8	1001.04.04	2	HA,STR
9	1316461	1	SHIELD, TRIM SHIELD
10	1311571	1	MANIFOLD, CUSTOM, TRIM
11	1320721	1	100R17AR-04X138",
12	1320711	2	100R17AR-06X38",
13	1008.06	2	SWIVEL NUT, RUN, -6ORFS
14	1003.04.04	1	HA,90°
15	155243	2	CARTRIDGE, PRESSURE RELIEF,
16	155246	2	CHECK VALVE, CARTRIDGE
17	155245	1	PILOT PISTON, DOUBLE ACTING
18	155247	2	BACKUP RING
19	155249	1	CARTRIDGE VALVE, 3 POS,4 WAY (INCLUDES 155248)
20	155248	2	SOLENOID COIL, CARTRIDGE, PROP
21	155244	1	NEEDLE VALVE, ADJUSTABLE FLOW
22	155242	1	VALVE BODY, TRIM

John Deere Header Lift Manifold Fittings

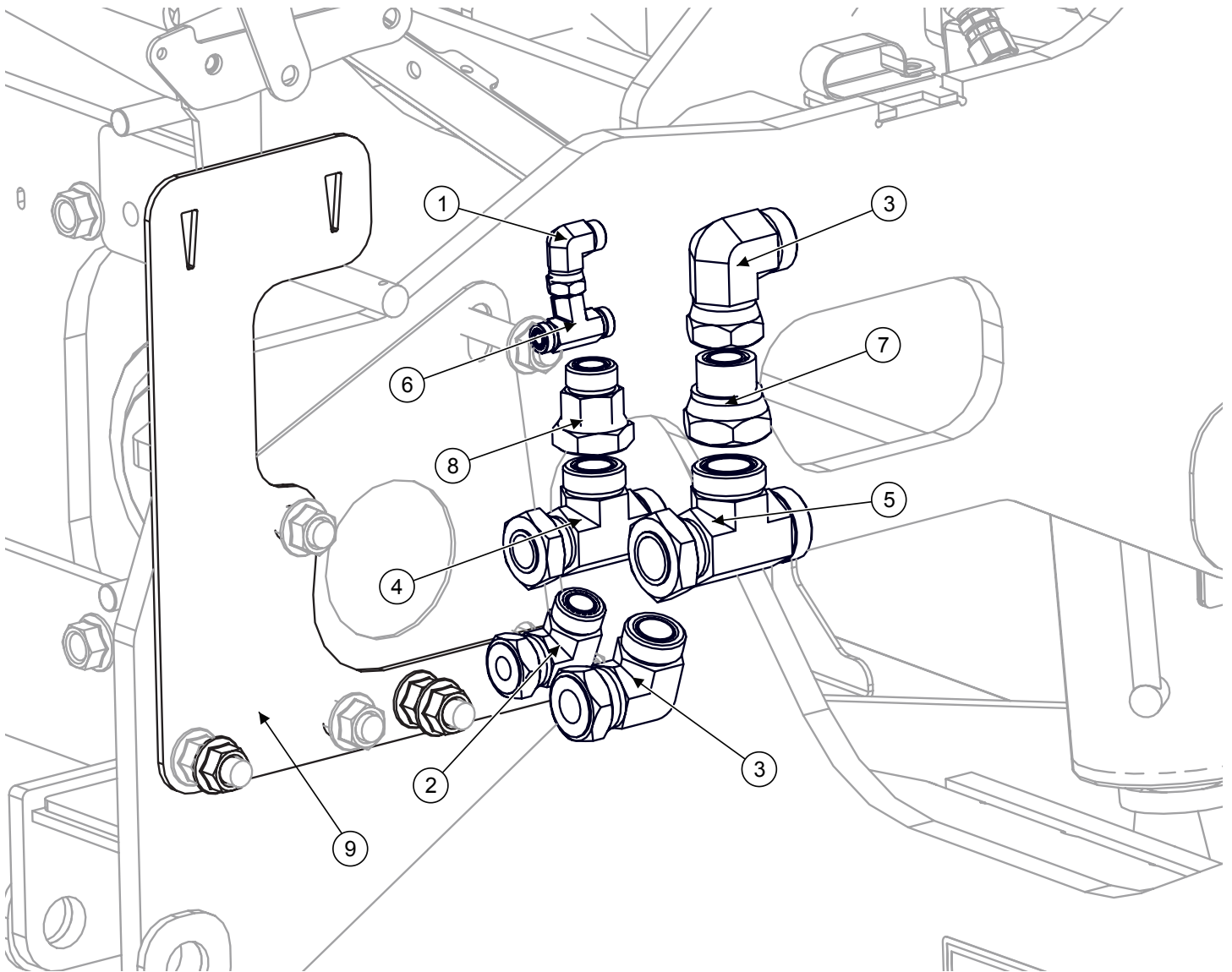

John Deere Header Lift Manifold Fittings			
BOM ID	Part No.	Qty	Description
1	1006.06.06	1	ELBOW, 90°, -6FF x -6MF
2	1006.12.12	1	ELBOW, 90°, -12MF x -12FF
3	1006.16.16	2	ELBOW, 90°, -16MF x -16FF
4	1008.16	1	TEE, SWIVEL NUT, RUN, #16
5	1008.20	1	TEE, SWIVEL NUT, RUN, #20
6	1008.06	1	TEE, SWIVEL NUT, RUN, -6FF x -6MF
7	1004.20.16	1	STR, -20FF x -16MF
8	1004.16.12	1	STR, 16FF x 12MF
9	1297821	1	MANIFOLD SPACER

Model JH9010 Hillco Leveling System
For Serial Numbers JH9010-15001 thru JH9010-15999

JH9010 Hydraulic Hoses			
Part No.	Qty	Where Used	Description
1138942	1	Grease Hose	100R1-03,
1138951	1	Grease Hose	100R1-03, 40"
1138963	1	Grease Hose	100R1-03, 54"
1138974	2	Grease Hose	100R1-03, 77"
1152451	1	CONNECTS YELLOW PORT TO SLAVE CYL BASE PORT ON STOCK CM EQUIPPED COMBINES	100R17AR-04X80",
1152461	1	CONNECT C/M BLUE PORT TO ROD PORT ON STOCK CM EQUIPPED COMBINES	100R17AR-04X70",
1273461	2	Extend Steer Hoses	100R17AR-06X15",
1273462	2	Replaces AH223259; Connect Proportionator Case Drain to Transmission	100R17AR-08X62",
1274141	1	Reverse Hydro Hose	797TC-20 X 124",
1293431	2	Extends Rear Hydrostat Line	100R17AR-06X47",
1295601	2	Leveling Manifold to Leveling Cyl	100R17AR-08X103",
1295882	2	Connects Master Cyl to Slave Cyl	451TC, 3/8" X 195"
1297421	1	Extends AH226084 to Proportionator Motor Supply	100R17AR-10X66",
1297441	1	Extends AH226085 to Proportionator Pump Supply	100R17AR-12X66",
1297452	1	Replaces AH219243; Connects Rear Filter Port to Proportionator Motor Return	100R17AR-10X127",
1297481	1	Extends AH226119 to the Trans Lube	100R17AR-06X31",
1297641	1	Extends Right Brake Hose	100R17AR-06X78",
1297651	1	Extends Left Brake Line; Extends Lube Line	100R17AR-06X60",
1297841	1	Return, Manifold to Tee	451TC, 3/4 X 60"
1297851	1	Pressure, Manifold to Tee	451TC-5/8" X 66"
1297863	1	Load Sense, Manifold to Tee	451TC-04 X 80"
1297922	1	Replaces JD Hose; Connects Manifold to Tee	
1297932	1	Replaces Left Header Lift Pressure Hose	451TC, 3/4" X 44",
1298291	1	Extends ProDrive Case Drain	100R17AR-16X36",
1298321	1	Replaces Right Header Lift Pressure Hose	451TC, 3/4"X42",
1298331	1	Replaces the Header Lift Pressure Hose	451TC, 1"X 90",
1299191	1	Extends JH Hose to Shift Block	100R17AR-04X15",
1305181	1	Replaces Forward Hydro Hose	797TC-20 121",
1320711	2	CONNECT "P" & "T" PORTS OF TRIM MANIFOLD TO JD MANIFOLD	100R17AR-06X38",
1320721	1	TRIM MANIFOLD LOAD SENSE TO JD HDR LIFT MANIFOLD	100R17AR-04X138",
1322101	1	CONNECTS "B" PORT TO SLAVE CYLINDER BASE PORT	100R17-04X80",
1322112	1	CONNECTS ROD PORT TO A PORT OF TRIM MANIFOLD	100R17-04 67",

Model JH9010 Hillco Leveling System
For Serial Numbers JH9010-15001 thru JH9010-15999

RETRACTABLE LADDER

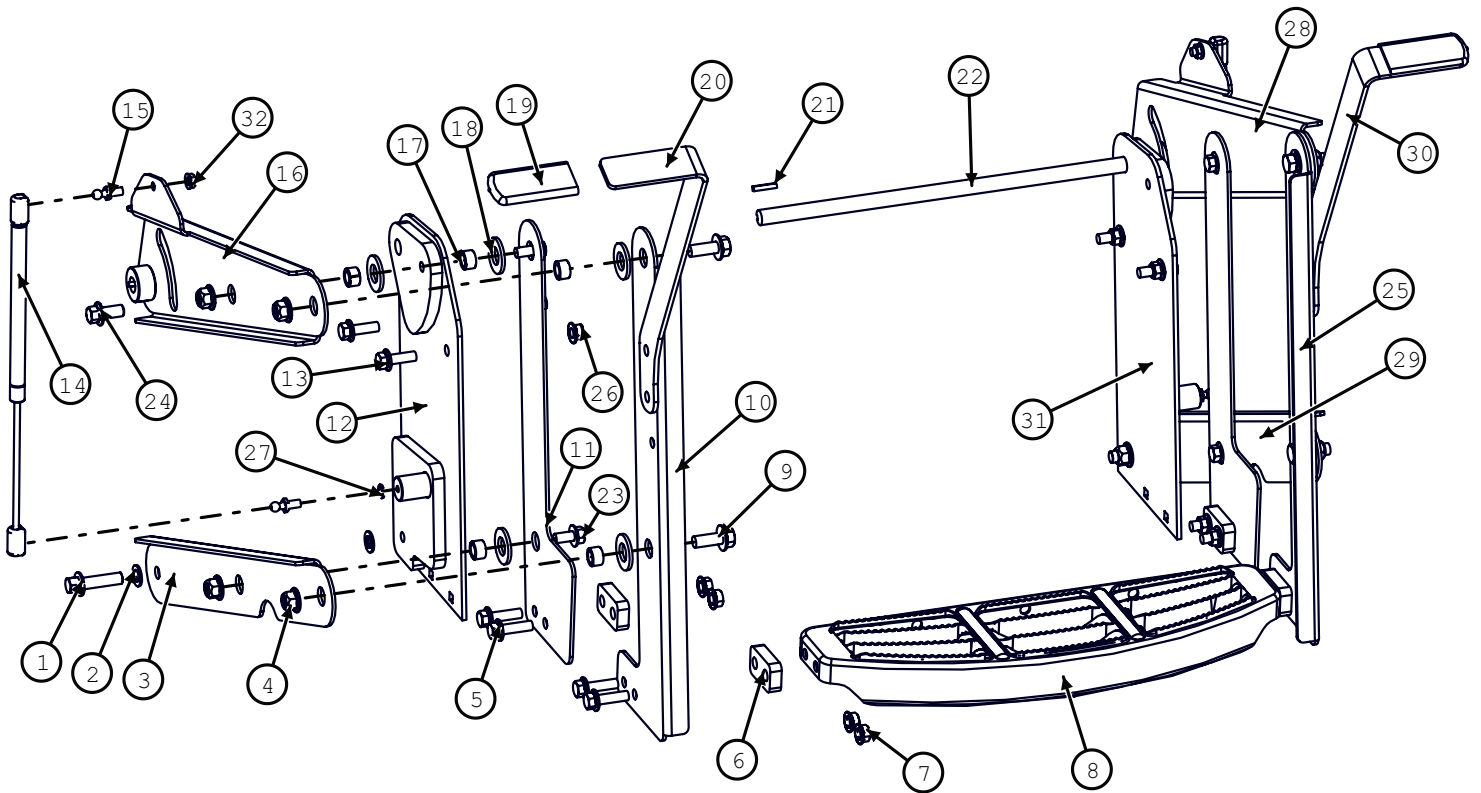

Model JH9010 Hillco Leveling System
For Serial Numbers JH9010-15001 thru JH9010-15999

Retractable Ladder

BOM ID	Part No.	Qty	Description
1-32	1300211	1	ASSEMBLY, MOVING STEP (HILLSIDE)
1	122.012.045	2	FLHC-10.9M12X1.75X45
2	162.014.008	4	MACHINE BUSHING 14GA NR 1/2ID
3	1300091	1	LM LINK, LWR RIGHT PARALLEL
4	128.012	10	FLHN-10.9M12X1.75 STVR
5	122.010.035	8	SCREW, FLANGED HEX CAP, 10.9
6	1300191	4	LM SPACER, STEP
7	123.01	12	FLHN-10.9 M10 X 1.50
8	152601	1	STEP, PLATFORM, STEP (HXE19816)
9	122.012.030	4	FLHC-10.9 M12X1.75X30
10	1300162	1	LM PLT, VERTICAL OUTER RIGHT
11	1300111	2	LM LINK, VERTICAL INNER
12	1300061	1	LM WLD, RHT LADDER MNT
13	122.010.030	4	FLHC 10.9 M10 X 1.5 X 30
14	155327	2	STRUT, LIFT, 100LB, 15OPC, 6" STROKE
15	134931	4	LIFT SUPPORT BRACKETS (PAIR)
16	1300121	1	LM WLD, TOP RIGHT LINK
17	1299181	10	LM BUSHING, LADDER PIVOT
18	153.010.012	10	MACHINE BUSHING 10GA WR 3/4ID
19	151921	2	GRIP, JD#W25634
20	1306351	1	LM PLT, HANDLE, LEFT
NS	1316512	1	LM PLT, HANDLE, LEFT - SHORT
21	10049.03.00016	2	KEY, STR, 3/16 X 3/16 X 1
22	1298191	1	LM RND, ROCK SHAFT
23	122.010.020	4	FLHC-10.9M10X1.75X20
24	122.012.025	2	FLHC-10.9M12X1.75X25
25	1300172	1	LM PLT, VERTICAL OUTER LEFT
26	128.01	4	FLHN-10.9M10X1.5 STVR
27	136.005	2	LOCK WASHER 5/16"
28	1300141	1	LM WLD, TOP LEFT LINK
29	1300101	1	LM LINK, LWR LEFT PARALLEL
30	1300182	1	LM PLT, LADDER HANDLE RIGHT
NS	1316502	1	LM PLT, HANDLE, RIGHT - SHORT
31	1300051	1	LM WLD, LEFT LADDER MNT
32	119.005	2	FLHN 5/16-18

Ladder Wedge

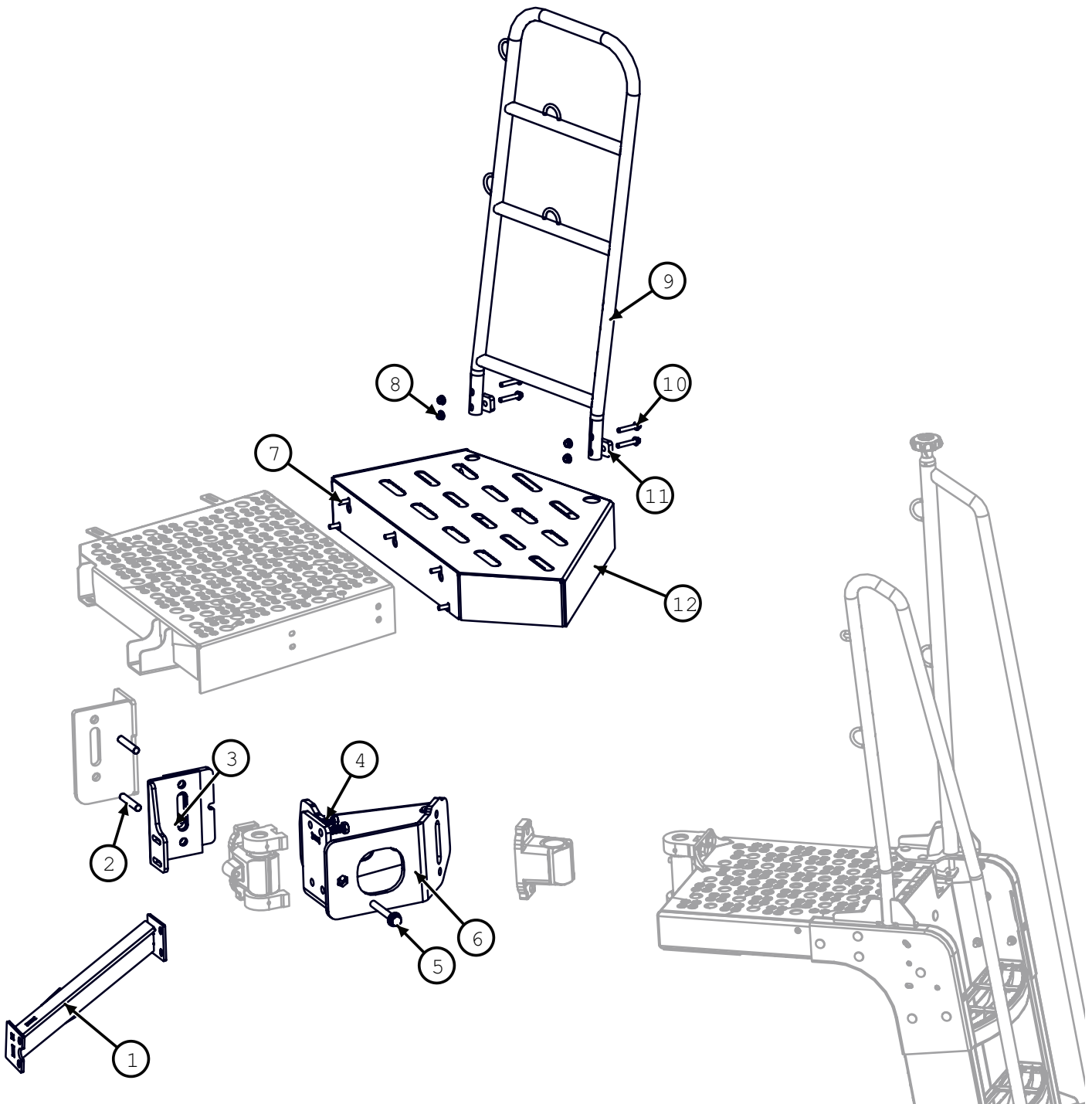

Model JH9010 Hillco Leveling System
For Serial Numbers JH9010-15001 thru JH9010-15999

Ladder Wedge

BOM ID	Part No.	Qty	Description
1	1296081	1	LM WLD, LADDER BRACE
2	155.016.090	2	STUD, DOUBLE-10.9 M16X2.00X90
3	1301181	1	LM ASM, SUPPORT BRACKET
4	122.016.040	4	HC 10.9M16X2.0X40
5	122.016.100	1	HC 10.9M16X2.0X100
6	1300932	1	LM WLD, PIVOT EXTENSION
7	122.010.030	5	FLHC 10.9 M10 X 1.5 X 30
8	F-HNF-10ME	4	FLHN-10.9 M10 X 1.50
9	MC-153571	1	HANDRAIL, EXTENSION ASSY FRONT (AXE16380)
10	122.010.060	4	FLHC-10.9M10X1.50X060
11	LP-307281	2	LM PLT, SPACER, PLATFORM
12	1301102	1	LM WLD, PLATFORM

Controller/Wiring Harnesses

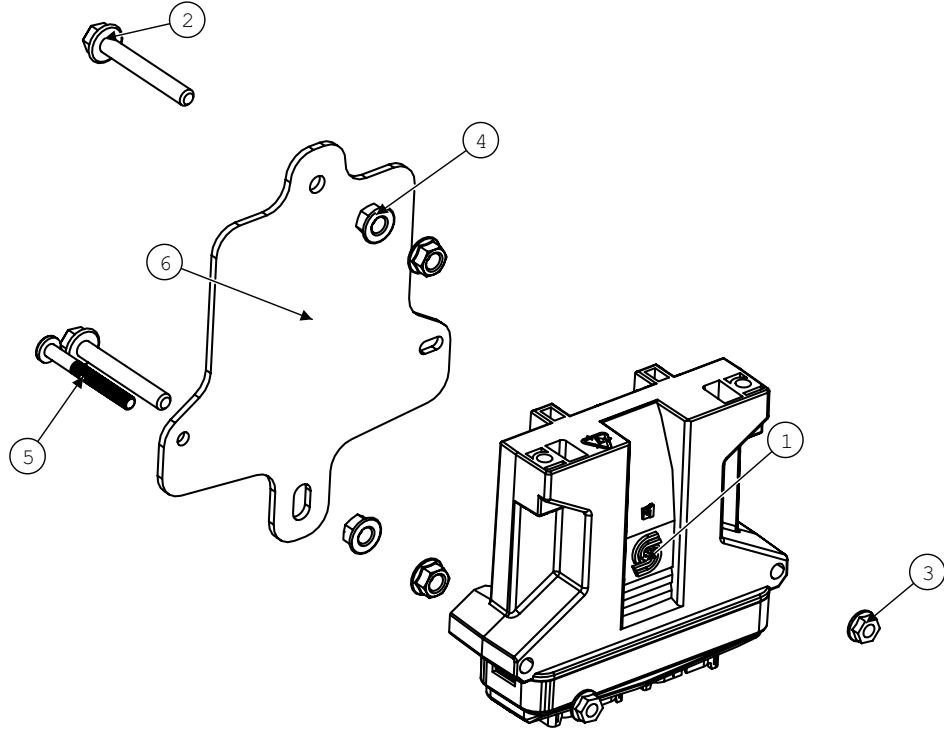

Electrical Components			
BOM ID	Part No.	Qty	Description
1	141831	1	SAUER-DANFOSS PLUS 1 CONTROLLER, PROGRAM 1296211
2	122.008.060	2	FLHC-M08X1.25X60
3	119.004	2	PHMS-GR5-1/4-20 X 2-1/4"
4	123.008	4	FLHN 10.9 M8 X 1.25
5	114.004.036	2	SCREW,PHM,CH,SERR
6	1295201	1	EM PLT, CONTROLLER MNT

Wiring Harnesses			
Part No.	Qty	Description	
NS 1294743	1	EM HARNESS, PRIMARY	
NS 1295181	1	EM HARNESS, SENSOR PACKAGE	
NS 1295342	1	EM HARNESS, TA SENSOR	
NS 1296841	1	EM HARNESS, DUAL CAN LINK	
NS 1319741	1	PRIMARY HARNESS, EXTENSION	
NS 1323231	1	CAB POWER PIGTAIL	
NS 1320731	1	HEADER TRIM	

Monitor

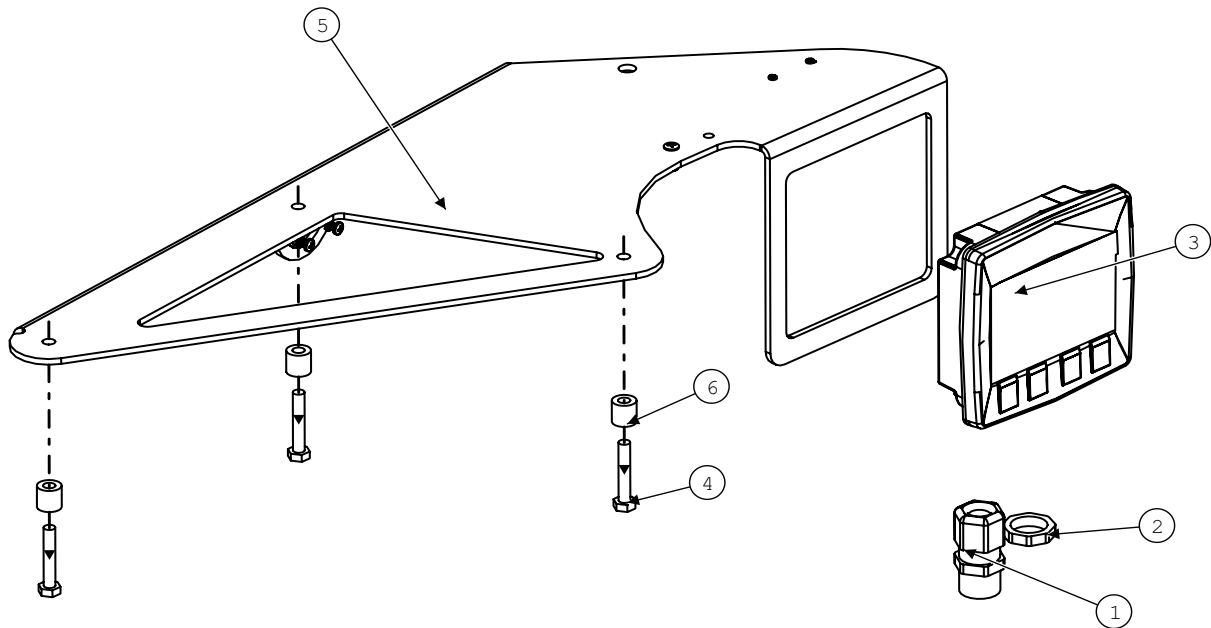

Electrical Components			
BOM ID	Part No.	Qty	Description
1	138781	1	STRAIN RELIEF, NYLON, BLK,
2	EC-142121	1	STRAIN RELIEF NUT, 1/2" BLACK
3	151591	1	DISPLAY, SAUER DANFOSS DP-250
4	120.006.035	3	HC-10.9 M6x1.0X35
5	1296702	1	EM MNT, HILLSIDE DISPLAY
6	151931	3	BUSHING, NYLON .25ID x .50D

Decals and Literature



1) LL-133741



2) LL-151041

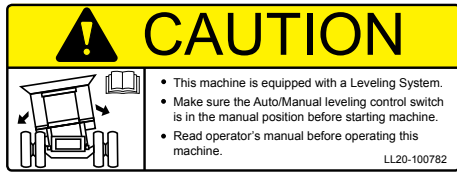

3) LL20-100782



5) LL20-100784



4) LL20-100783

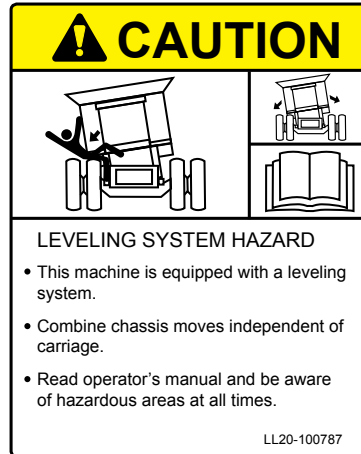

7) LL20-100787



6) LL20-100786



8) LL20-100788

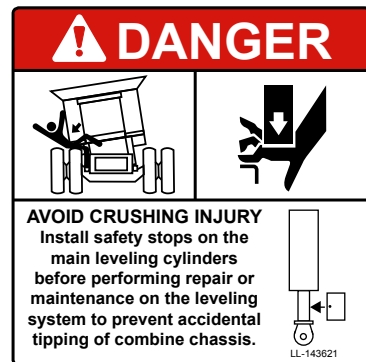

9) LL-143621

Model JH9010 Hillco Leveling System
For Serial Numbers JH9010-15001 thru JH9010-15999

DECALS AND LITERATURE				
REF.	PART NO.	QTY.	PART NAME	DESCRIPTION
1	LL-133741	1	LABEL, GREASE 50 HRS	OC BULKHEAD
1	LL-133741	2	LABEL, GREASE 50 HRS	RIGHT & LEFT MAIN LEV CYL BOTTOM
1	LL-133741	1	LABEL, GREASE 50 HRS	MASTER CYLINDER ROD
2	LL-151041	2	DECAL, HILLSIDE LEVELING SYSTEM	SIDE OF COMBINE
3	LL20-100782	1	CAUTION LEVELING SYSTEM CAB	WINDOW IN CAB
4	LL20-100783	2	DANGER, CRUSHING HAZARD	RIGHT & LEFT UNDERCARRIAGE
4	LL20-100783	2	DANGER, CRUSHING HAZARD	SIDES OF DROP AXLE ASSEMBLY
5	LL20-100784	2	DECAL, DANGER PINCH POINT	RIGHT & LEFT UPPER TRANS FACE PLT
6	LL20-100786	1	WARNING ELECTRICAL CRUSHING HAZARD	FRONT OF ELECTRICAL CONTROL BOX
7	LL20-100787	1	CAUTION - LEVELING SYSTEM HAZARD	ON LADDER PLATFORM
8	LL20-100788	1	DANGER - HYDRAULIC HAZARD	ON SIDE OF COMBINE ABOVE THE HYDRAULIC MANIFOLD
8	LL20-100788	2	DANGER - HYDRAULIC HAZARD	FOR EACH LEVELING CYLINDER
9	LL-143621	2	DANGER, AVOID CRUSHING INJURY	IN AREA NEAR SAFETY STOP STORAGE LOCATION
NS	LL-147651	1	LABEL, FEMA MEMBER TAG	NEAR SERIAL NUMBER TAG
NS	LA-255961	1	TAG, SERIAL NUMBER	
NS	LL-289641	1	CM LABEL, MECHANICAL CYLINDER STOP	
NS	D-120613CMA01D	1	MANUAL, PARTS	
NS	D-120427MCA01C	1	MANUAL, OPERATORS	SN 15001-15999
NS	D-050611SLR01	1	WARRANTY REGISTRATION CARD	
NS	LL-239412	1	LABEL, STEERING WHEEL	TIED TO STEERING WHEEL DURING INSTALLATION
NS	D-120412CMA01	3	DEALER PDI & INSTALL CHECKLIST	

Model JH9010 Hillco Leveling System
For Serial Numbers JH9010-15001 thru JH9010-15999

Notes

Hillco Technologies, Inc.
107 1st Avenue
Nezperce, Idaho 83543

Phone	800-937-2461
	208-937-2461
Fax	208-937-2280

www.hillcotechnologies.com
email: support@hillcotechnologies.com