

Model CH9010 Hillco Leveling System
For Serial Numbers CH9010-15001 thru CH9010-15999



Model CH9010 Hillside Leveling System Parts Manual

SN CH9010-15001 thru CH9010-15999
For Case-IH 7240, 8240, and 9240
Combines

D-120623CMA0C



CH9010 Hillside Leveling System

For Case-IH 7230, 8230, and 9230 Combines

Table of Contents

General Information	3
Serial Number Location	3
Text and Illustrations	3
Abbreviations	3
Right and left Identification	3
Part Orders	3
TRANSITION	4
Transition Throat	5
Paddle Beater Drive	6
Steel Paddle Beater	8
Rubber Paddle Beater	9
Slave Cylinder	10
Transition Header Adapter	11
DRIVE WHEEL	13
CARRIAGE	14
Overcarriage	14
Undercarriage	16
DROP AXLE	17
LADDER	18
ELECTRICAL	20
Leveling Box	21
Monitor & Remote Switches	22
Electrical Harnesses	24
HYDRAULICS COMPONENTS	25
Leveling Manifold	27
Hydro Hose Accessories	29
Hydraulic Hoses	31
MISCELLANEOUS	32

Contact Information

Hillco Technologies, Inc.
107 1st Avenue
Nezperce, Idaho 83543

Phone 800-937-2461
208-937-2461
Fax 208-937-2280

www.hillcotechnologies.com
email: support@hillcotechnologies.com

GENERAL INFORMATION

SERIAL NUMBER LOCATION

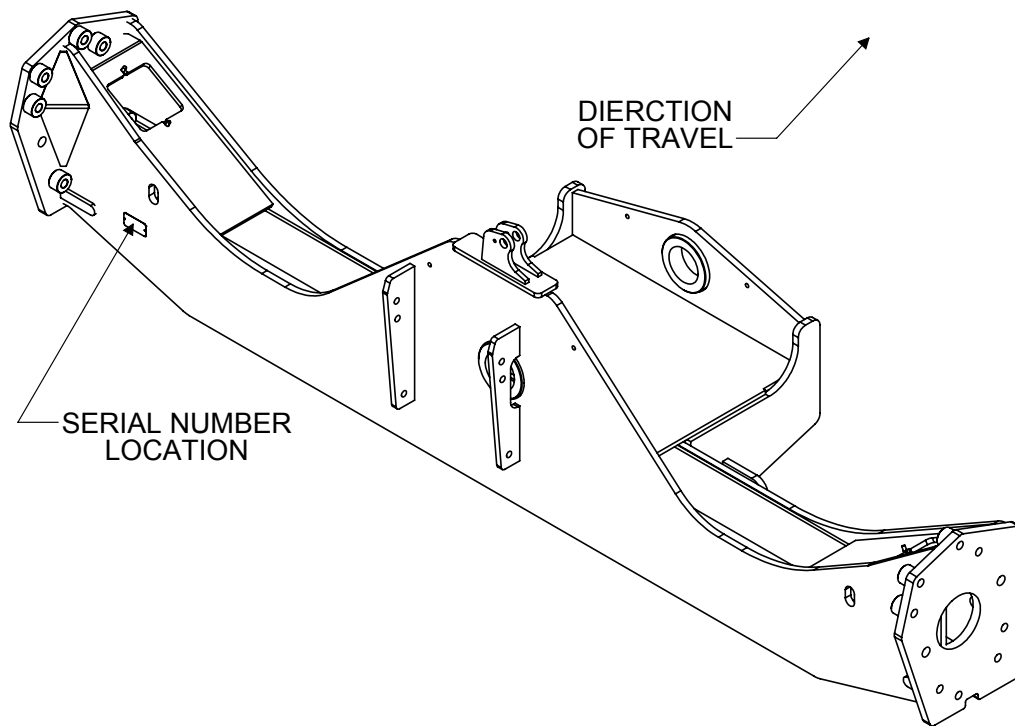

TEXT AND ILLUSTRATIONS

The arrangement of this parts catalog is for easy identification of parts. All parts are illustrated in exploded views in proper relation to each other. Some diagrams refer to other pages for further information. Reference numbers used in the illustrations refer to line numbers in the part lists. The part lists appear to the right or below all diagrams and correspond with those diagrams. Included in the part lists, along with the reference numbers are part numbers, part descriptions and the quantity of the part required per leveling system.

ABBREVIATIONS

SN "Serial Number" refers to the serial number given to each leveling system (by Hillco Technologies), as well as the serial number given to the combine (by the specific combine manufacturer) the leveling system is installed. See above for the leveling system's serial number location. This abbreviation is used interchangeably in both instances. Each Model CH9010 Leveling System uses the following serial number format: CH9010-XXXX (sequential numbers).

ASM "Assembly" refers to a whole grouping of parts (shown in the diagram corresponding with the page where "ASM" is shown unless otherwise noted). Some assemblies have parts that are sold separately, however some must be purchased as a single unit. Hillco Product Specialists will be able to assist you with any questions.

NS "Not Shown" refers to a part that is not depicted in the illustration.

RIGHT AND LEFT IDENTIFICATION

The reference to right-hand and left-hand in this catalog is identified by the operator sitting in the operator's seat, looking toward the front of the machine (in normal forward travel).

PART ORDERS

Orders must specify product model, serial number, correct part number, complete description, quantity required, method of shipment, shipping address, and billing address.

TRANSITION

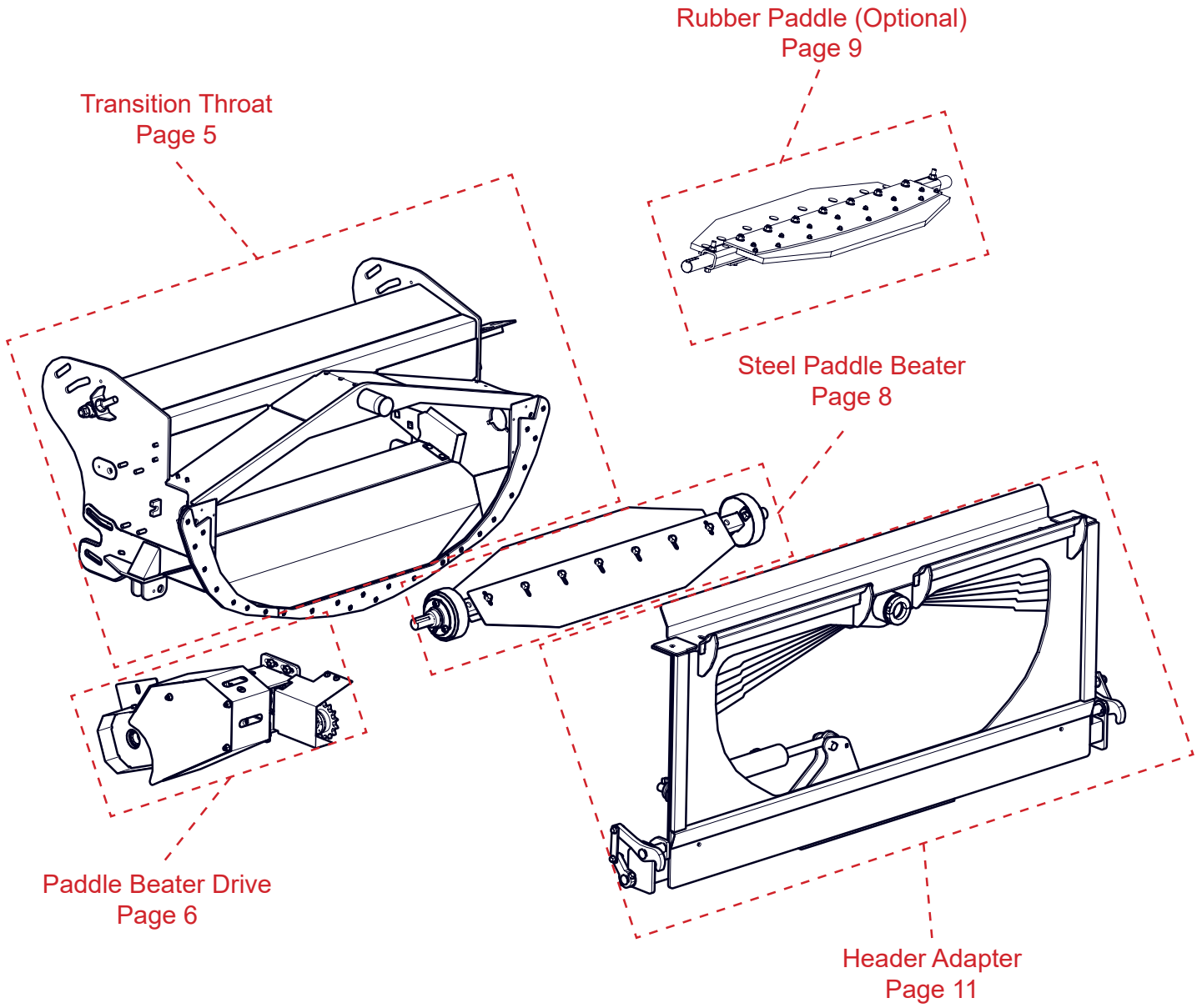

Model CH9010 Hillco Leveling System
For Serial Numbers CH9010-15001 thru CH9010-15999

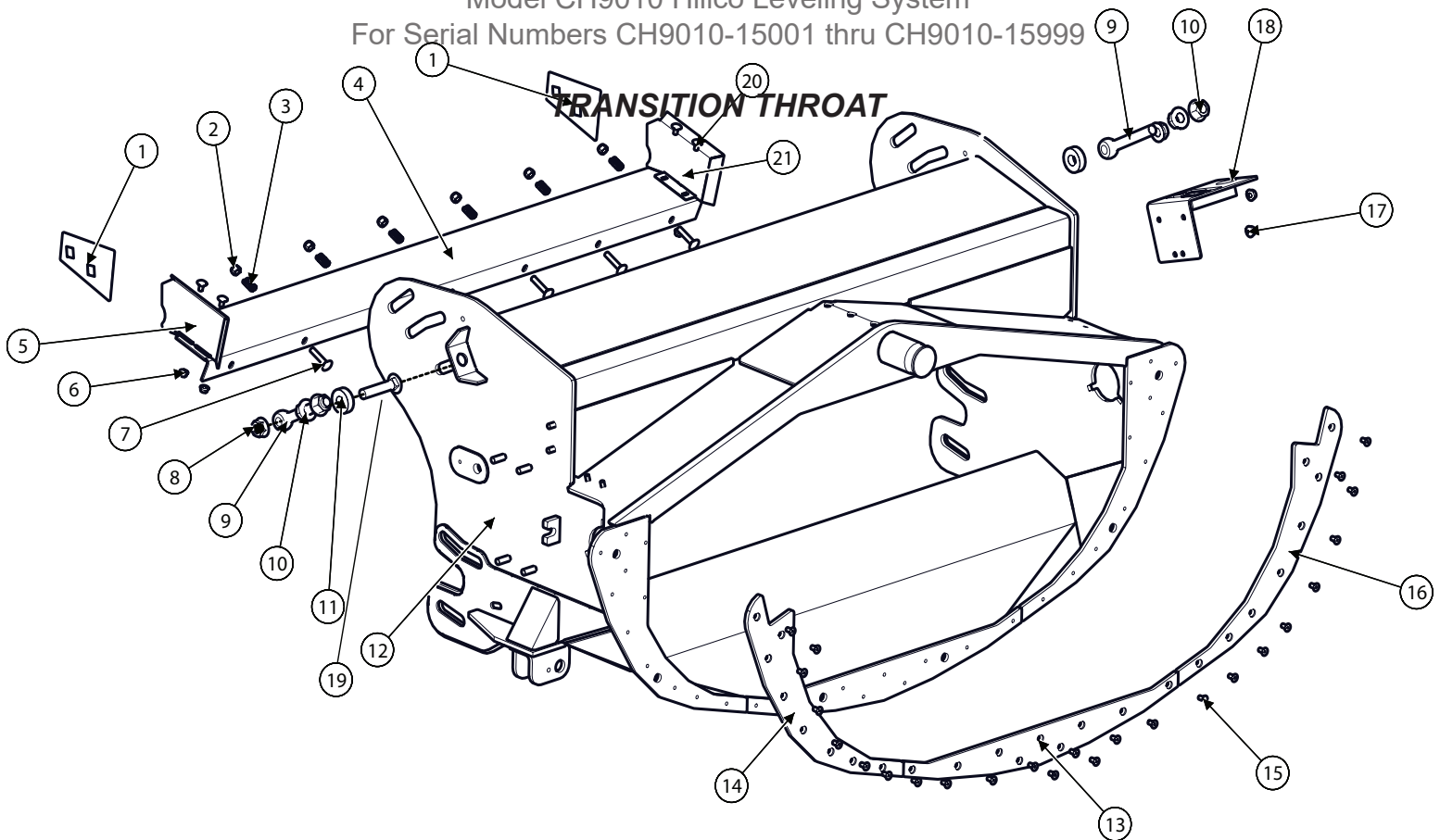

Transition Throat			
BOM ID	Part No.	Qty	Description
1	1306191	2	REAR SEAL
2	191.01	7	NUT,HX,NYL,CL8 M10
3	143591	7	SPRING, COMPRESSION
4	1305431	1	FLOOR PLATE, FLEX
5	1306251	1	FLOOR SEAL, RIGHT
6	123.008	4	NUT,HX,FL,CL10 M8
7	163.010.050	7	BOLT,CARR,CL8.8 M10
8	119.012	2	NUT,HX,FL,SERR 3/4-10
9	169.020.150	2	BOLT,EYE M20X150
10	123.02	4	NUT,HX,FL,CL10 M20
11	1251791	2	EYEBOLT SPACER
12	1305281	1	THROAT
13	1255182	1	WEAR PLATE, BOTTOM
14	1255202	1	WEAR PLATE,RHT
15	164.008	25	SCREW,FHSC,CL10.9 M8X16
16	1255192	1	WEAR PLATE,LFT
17	123.01	2	NUT,HX,FL,CL10 M10
18	1253621	1	HYDRAULIC COUPLER
19	107.012.056	2	BOLT,CARR,GR5 3/4-10X3-1/2
20	163.008.016	4	BOLT,CARR,CL8.8 M8X16
21	1306241	1	FLOOR SEAL, LEFT

PADDLE BEATER DRIVE

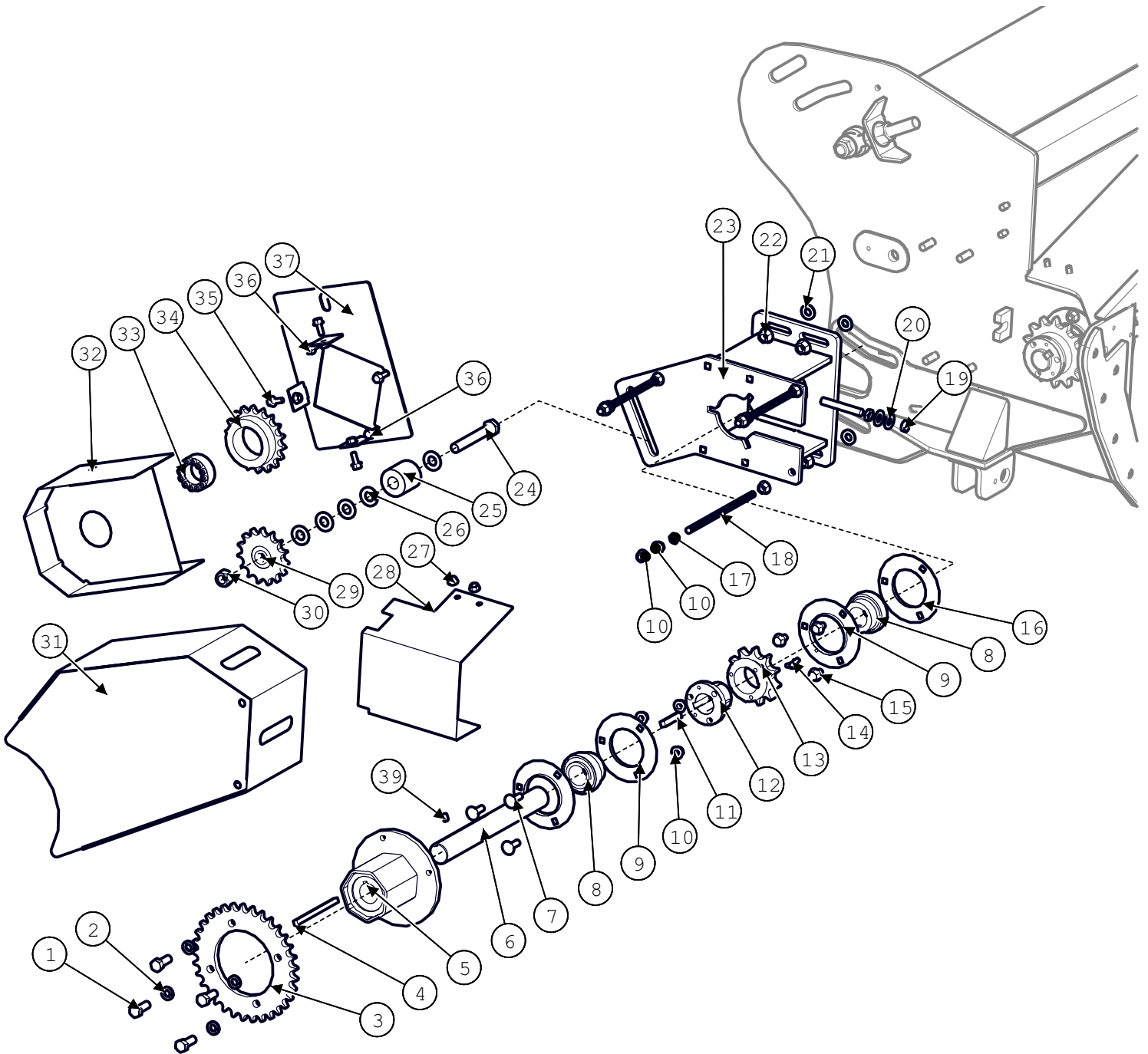

Model CH9010 Hillco Leveling System
For Serial Numbers CH9010-15001 thru CH9010-15999

Paddle Beater Drive			
BOM ID	Part No.	Qty	Description
1	167.008.020	4	BOLT,HX,GR8 1/2-20X1-1/4
2	139.008	4	WASHER,LCK,HVY-SPLIT 1/2
3	1226532	1	SPROCKET, SLIP CLUTCH
4	10049.05.00080	1	SQ,1018,CD 5/16X5
5	150071	1	SLIP CLUTCH
6	1251771	1	JACK SHAFT
7	163.010.030	3	BOLT,CARR,CL8.8 M10
8	153861	2	INSERT,BEARING, 1-7/16
9	153551	2	FLANGETTE, GREASABLE
10	123.01	15	NUT,HX,FL,CL10 M10
11	10049.06.00032	1	SQ,1018,CD 3/8X2
12	135511	1	HUB, SPLIT TAPER
13	135491	1	SPROCKET, TAPER BORE
14	141931	1	ZERK, 45°,1/4-28M TAPER, LINCOLN
15	122.010.016	3	BOLT,HX,FL,CL10.9 M10X16
16	153541	2	FLANGETTE, GREASABLE
17	165.01	3	NUT,HX,JAM,CL8 M10
18	10069.10.00200	3	ALLTHREAD,GRB7 M10X200
19	165.012	2	NUT,HX,JAM,CL8 M12
20	133.008	2	WASHER,L9,HD 1/2
21	153.010.008	4	BUSHING,MACH,WR,
22	123.012	4	NUT,HX,FL,CL10 M12
23	1305571	1	MOUNT, JACK SHAFT
24	121.016.110	1	BOLT,HX,CL10.9 M16X110
25	1251881	1	SPACER, SPROCKET
26	133.01	5	WASHER,L9,HD 5/8
27	123.008	2	NUT,HX,FL,CL10 M8
28	1293461	1	CHAIN SHIELD, 80P
29	100237	1	SPROCKET, IDLER, 60P
30	126.016	1	NUT,HX,STV,CL10 M16
31	1305641	1	FRONT SHIELD
32	1305711	1	DRIVE SHIELD,
33	101838	1	HUB, POWER LOCK, 1-3/8
34	1255211	1	SPROCKET,POWERLOCK
35	122.008.020	3	BOLT,HX,FL,CL10.9 M8X20
36	122.008.025	3	BOLT,HX,FL,CL10.9 M8X25
37	1305681	1	DRIVE SHIELD,
39	158.006.008	2	SCREW,SKT,SET 3/8-16X1/2
40	126.008	3	NUT,HX,STV,CL10 M8
Drive Chains			
NS	10068.073	1	CHAIN,60P,73PITCHES
NS	10066.031	1	CHAIN, 80P, 31PITCHES

STEEL PADDLE BEATER

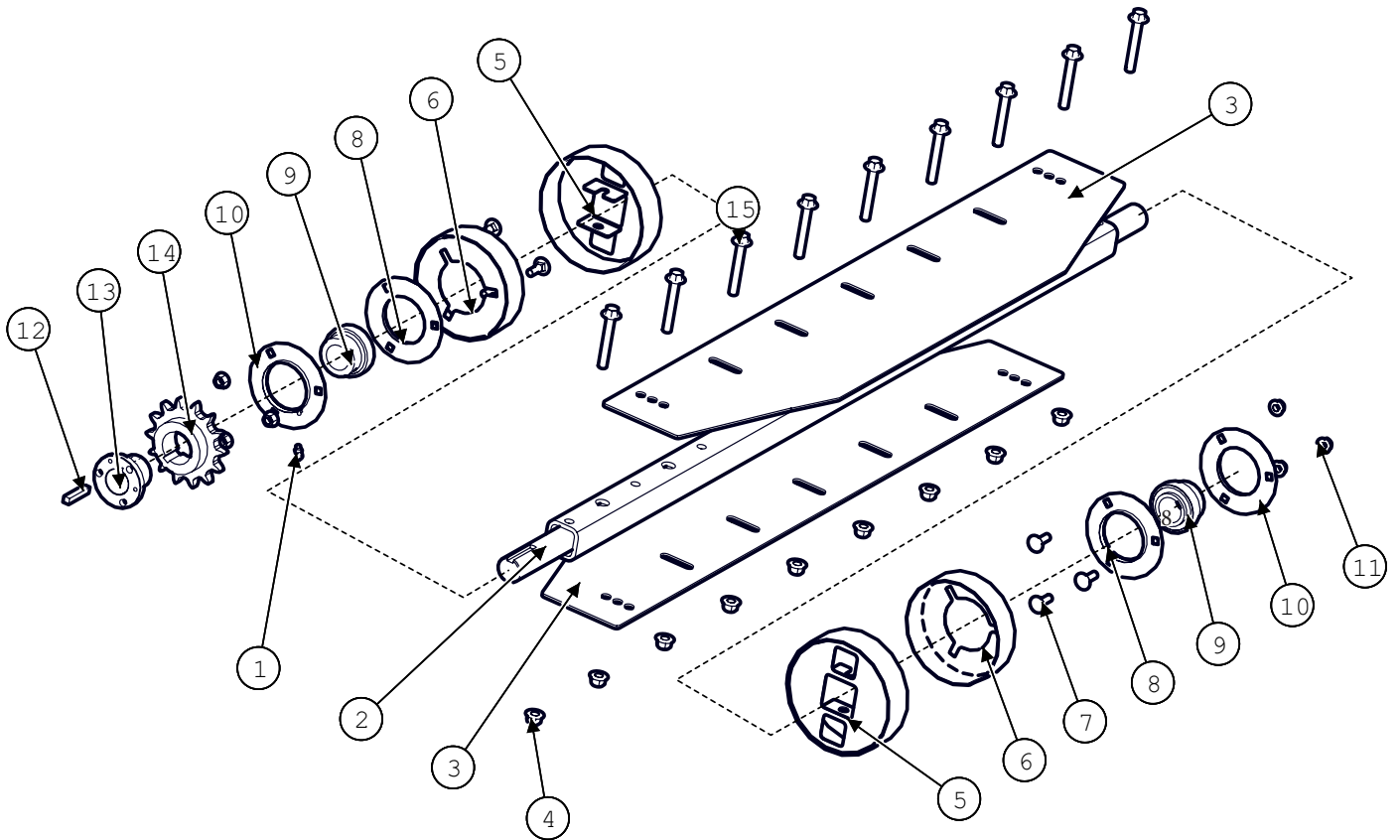

Paddle Beater			
BOM ID	Part No.	Qty	Description
1	141931	1	ZERK, 45°,1/4-28M TAPER, LINCOLN
2	1251632	1	BEATER SHAFT
3	1286321	2	PADDLE,METAL,NARROW
4	128.012	9	NUT,HX,FL,STV,CL10 M12
5	1292661	2	BEARING COVER, SHAFT
6	1292671	2	BEARING COVER, WALL
7	163.010.030	6	BOLT,CARR,CL8.8 M10
8	153541	2	FLANGETTE, GREASABLE
9	153861	2	INSERT,BEARING, 1-7/16
10	153551	2	FLANGETTE, GREASABLE
11	123.01	6	NUT,HX,FL,CL10 M10
12	10049.06.00032	1	SQ,1018,CD 3/8X2
13	135511	1	HUB, SPLIT TAPER
14	136151	1	SPROCKET, TAPER BORE
15	122.012.080	9	BOLT,HX,FL,CL10.9 M12X80

RUBBER PADDLE BEATER

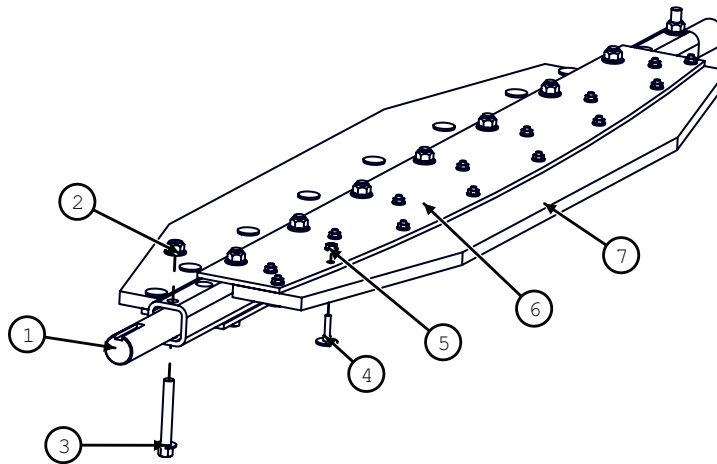

RUBBER PADDLE BEATER			
BOM ID	Part No.	Qty	Description
1	F-EB-04C20	30	ELEVATOR BOLT
2	F-HCF-12M080E	9	MM FLHC-10.9 M12 X 1.75 X 80 Plated
3	F-HNF-04C	30	FLHN-GR5 1/4-20
4	F-HNSF-12ME	9	FLHN-10.9 M12 X 1.75 STVR
5	LA-251632	1	TB ASM, SHAFT
6	LP-272172	2	TB PLATE, PADDLE BACKING
7	LP-272182	2	TB PADDLE, RUBBER

Model CH9010 Hillco Leveling System
 For Serial Numbers CH9010-15001 thru CH9010-15999

SLAVE CYLINDER

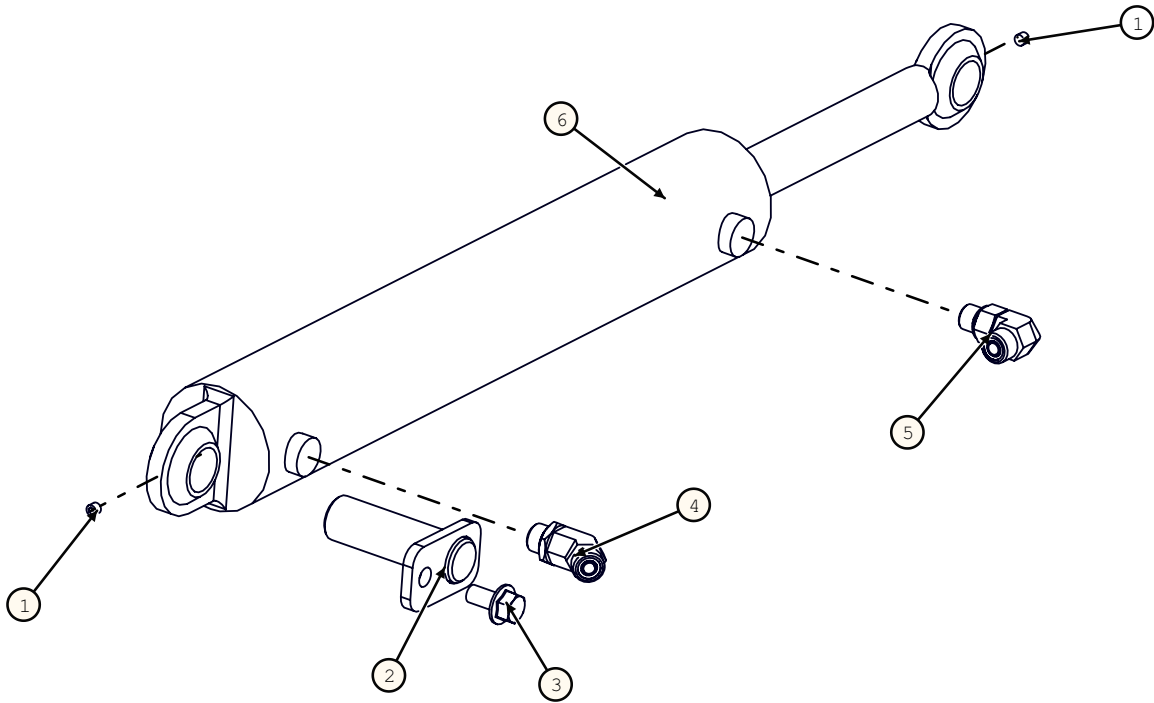

SLAVE CYLINDER			
BOM ID	Part No.	Qty	Description
1	F-SSS-04F04	2	SCREW, SOCKET SET 1/4-28 X 1/4
2	LA-229071	1	TM PIN ASM, BASE END
3	F-HCF-10M020E	1	FLHC-10.9 M10 X 1.5 X 20 PLT
4	HA-F-6MF6MO	1	#6 MORS X #6 MORB 45 DEG
5	HA-L-6MF6MO	1	ELBOW, 90°, 6MF x 6MO
6	HC-147491	1	CYL, 1-1/8" R, 12-1/2" S, 2-1/2 B, 21" CPC
NS	HC-141281	1	SEAL KIT, SLAVE CYLINDER

TRANSITION HEADER ADAPTER

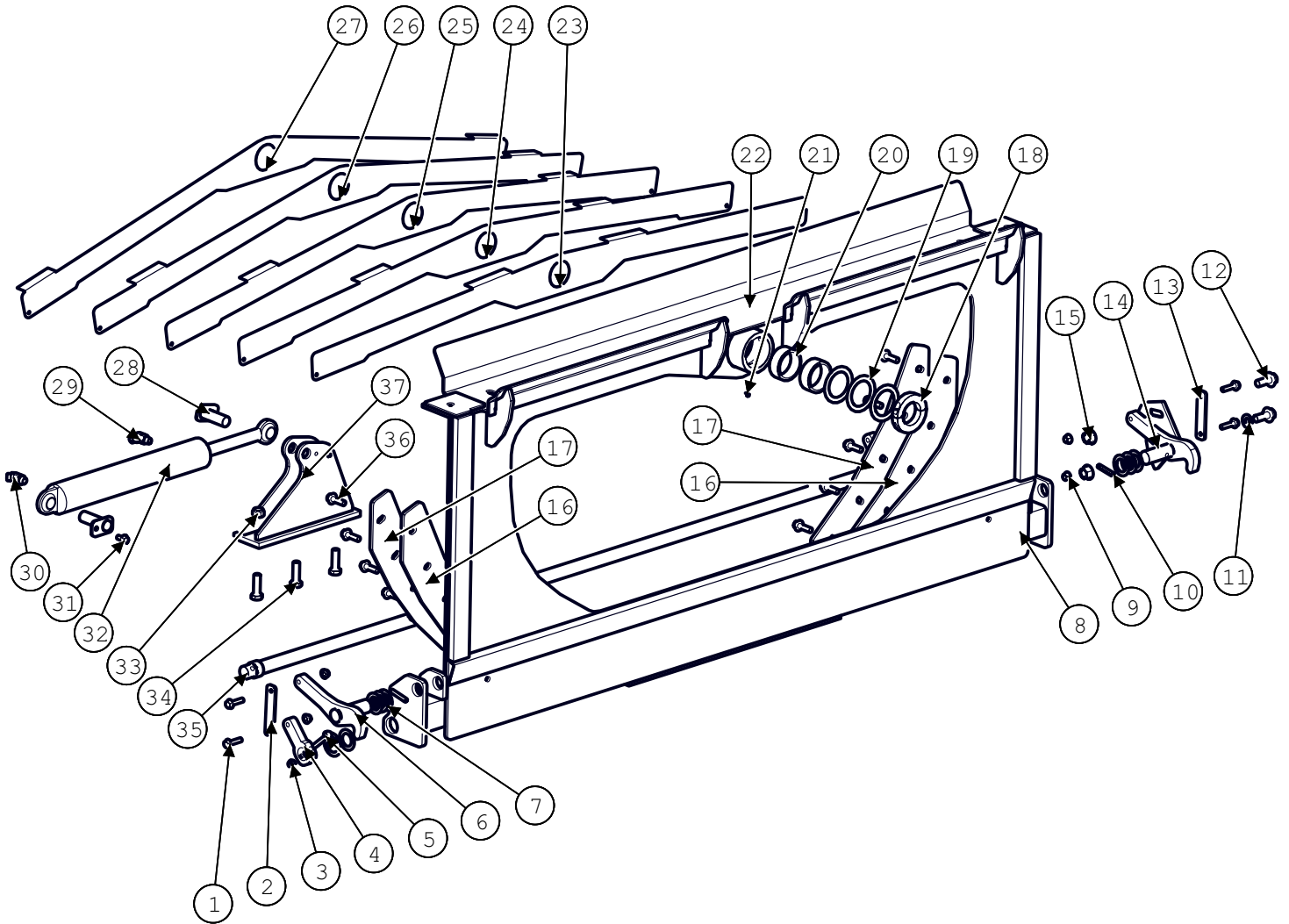

Model CH9010 Hillco Leveling System
For Serial Numbers CH9010-15001 thru CH9010-15999

Header Adapter			
BOM ID	Part No.	Qty	Description
1	122.010.040	4	BOLT,HX,FL,CL10.9 M10X40
2	1270211	1	LINKAGE, HDR LOCK, RHT
3	126.01	1	NUT,HX,STV,CL10 M10
4	1270191	1	PIVOT ARM, LOWER, RHT
5	122.010.060	1	BOLT,HX,FL,CL10.9 M10X60
6	1270251	1	HEADER LOCK, RHT
7	162.018.020	7	BUSHING,MACH
8	162.018.024	2	BUSHING,MACH
9	128.01	4	NUT,HX,FL,STV,CL10 M10
10	140.006.032	2	PIN,ROLL 3/8X2
11	133.01	1	WASHER,L9,HD 5/8
12	122.016.040	2	BOLT,HX,FL,CL10.9 M16X40
13	1270201	1	LINKAGE, HDR LOCK, LFT
14	1270261	1	HEADER LOCK, LFT
15	123.016	2	NUT,HX,FL,CL10 M16
16	1249871	2	WEAR PLATE,
17	1255122	2	BACKING PLATE
18	150742	1	COLLAR,CLAMPING,2-1/2 ID 3-3/4 OD, 2 PIECE
19	162.014.040	3	BUSHING,MACH,NR
20	1305471	2	PIVOT BUSHING
21	133891	1	ZERK, GREASE, 1/8
22	1251516	1	HEADER ADAPTER
23	1306631	1	FRONT DEFLECTOR
24	1306621	1	FRONT DEFLECTOR, INNER
25	1306611	1	MIDDLE DEFLECTOR
26	1306601	1	REAR DEFLECTOR, INNER
27	1306591	1	REAR DEFLECTOR
28	1229071	2	CYLINDER PIN, TRIM
29	1003.06.06	1	-6MORB X -6MORFS
30	1002.06.06	1	HA,45°
31	122.010.020	2	BOLT,HX,FL,CL10.9 M10X20
32	147491	1	CYLINDER,SLAVE,21"CPC
33	126.016	3	NUT,HX,STV,CL10 M16
34	121.016.050	3	BOLT,HX,CL10.9 M16X50
35	1270272	1	CROSS SHAFT, HDR LOCK
36	122.012.040	10	BOLT,HX,FL,CL10.9 M12X40
37	1255141	1	ROD MOUNT

WHEEL

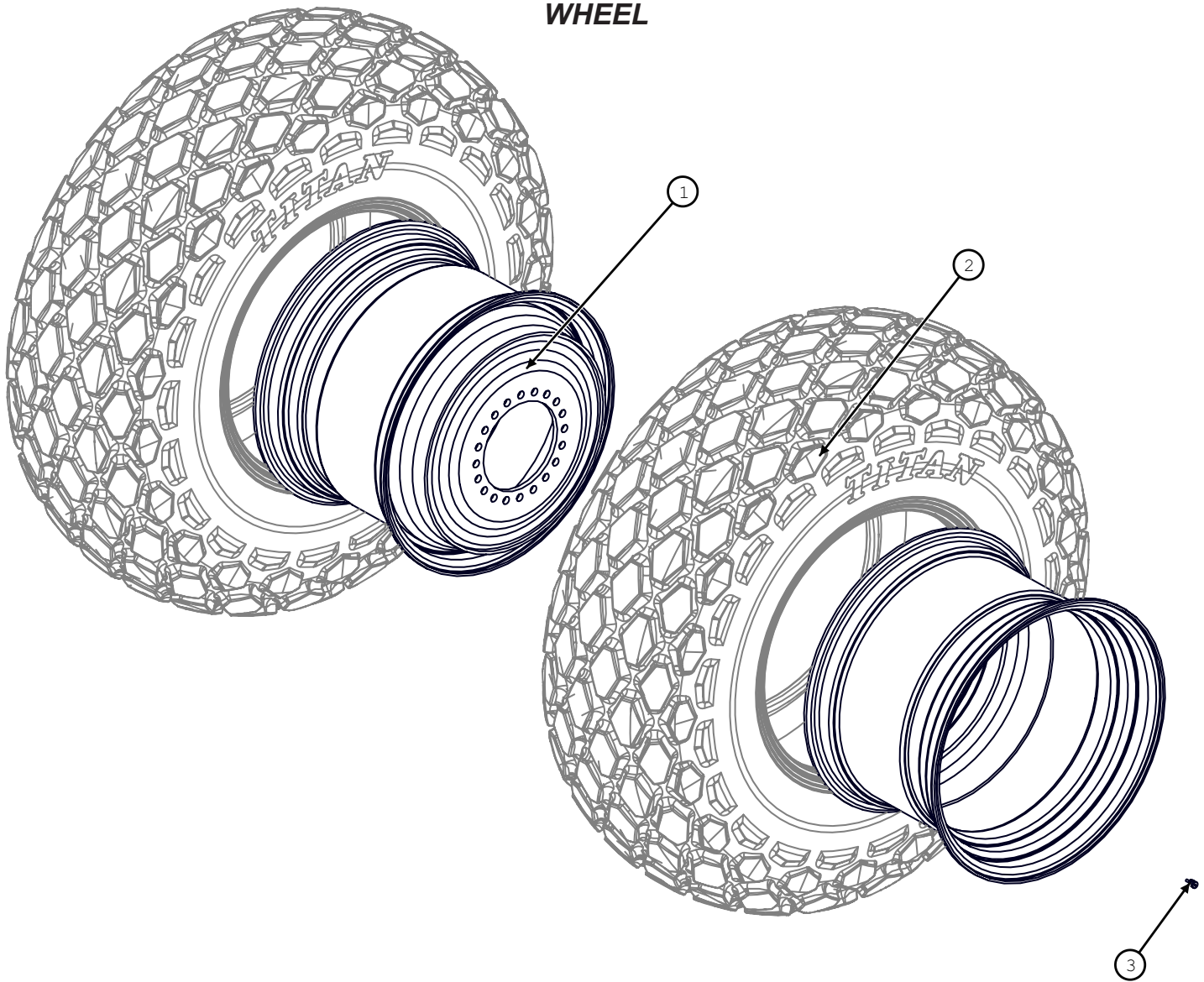

WHEEL COMPONENTS				
REF.	PART NO.	QTY.	PART NAME	NOTES
1	MC-143121	4	WHEEL, 32XDWH21 20-13.19-	
2	-	4	24.5 x 32 6* R3	CONTACT LOCAL TIRE SUPPLIER
NS	-	4	24.5 x 32 6* R1	CONTACT LOCAL TIRE SUPPLIER
3	MC-143921	4	VALVE STEM	
WHEEL FASTENERS				
REF.	PART NO.	QTY.	PART NAME	NOTES
NS	N/A	20	BOLT	CASE P/N 87283525
NS	N/A	10	SPACER PLATE	CASE P/N 87253501
NS	N/A	20	NUT	CASE P/N 336845

OVERCARRIAGE

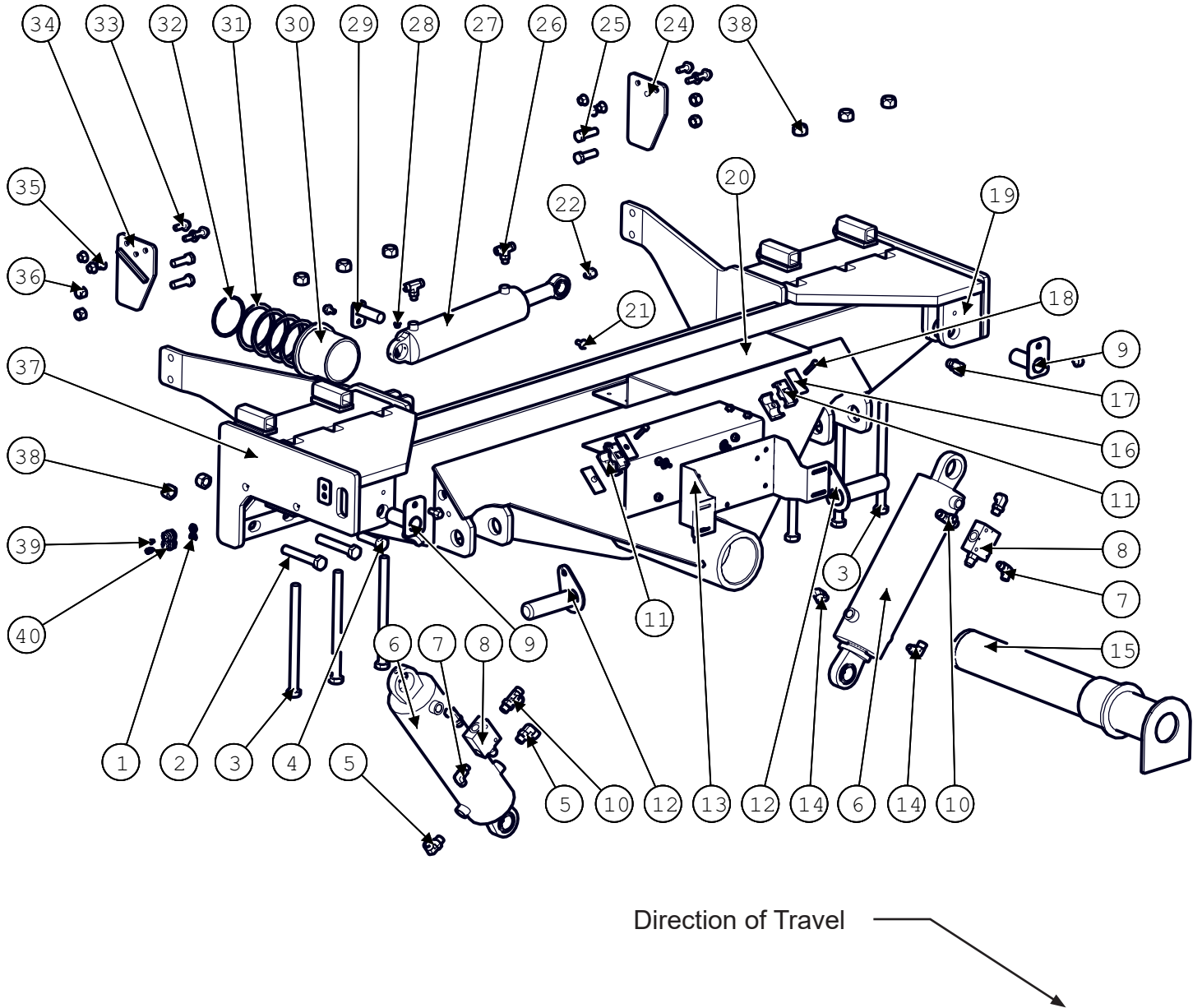

Model CH9010 Hillco Leveling System
For Serial Numbers CH9010-15001 thru CH9010-15999

Overcarriage			
BOM ID	Part No.	Qty	Description
1	155158	3	BULKHEAD,LOCKNUT
2	121.020.120	4	BOLT,HX,CL10.9 M20X120
3	121.020.280	6	BOLT,HX,CL10.9 M20X280
4	121.020.070	2	BOLT,HX,CL10.9 M20X70
5	1003.08.08	2	BOLT,HX,CL10.9 M20X120
6	147522	2	BOLT,HX,CL10.9 M20X280
7	1003.06.06	2	BOLT,HX,CL10.9 M20X70
8	139151	2	VALVE,COUNTERBALANCE,
9	1230551	2	CYLINDER, LEVELING
10	1007.08	2	STR, THD, RUN -8ORFS
11	140461	2	CLAMP, TWIN BEHRINGER 7/8DIA
12	1255301	2	CYL PIN, HEADER LIFT
13	1251432	1	MOUNT, LEVELING BOX
14	1003.08.06	2	-8MORB X -6MORFS
15	1247481	1	PIVOT PIN, MAIN
16	139451	2	COVER PLATE,TWIN
17	1028.08.08	2	-8MORB X -8MORB
18	101.005.028	2	CM WLD,PIVOT PIN, MAIN
19	133741	1	LABEL, GREASE, 50HRS
20	1293801	1	BOX COVER, ELECTRICAL
21	122.010.020	2	BOLT,HX,FL,CL10.9 M10X20
22	135881	1	ADAPTER,GREASE,STR
24	1251471	1	MOUNT, SWING ARM, LEFT
25	121.016.050	4	BOLT,HX,CL10.9 M16X50
26	1009.06	2	STR THD, BRANCH,
27	147501	1	CYLINDER, MASTER, 3"B,
28	135771	2	ADAPTER,GREASE,90°
29	1253884	1	CYLINDER PIN, TRIM
30	1247961	2	PIVOT BUSHING
31	138641	4	WASHER, 4.7640D X 048
32	138651	1	SNAP RING; 4"
33	122.012.030	6	BOLT,HX,FL,CL10.9 M12X30
34	1251481	1	MOUNT, SWING ARM
35	123.012	6	NUT,HX,FL,CL10 M12
36	126.016	4	NUT,HX,STV,CL10 M16
37	1251492	1	OVERCARRIAGE
38	126.02	16	NUT,HX,FL,CL10 M12
39	140471	3	NUT,HX,STV,CL10 M16
40	155157	3	BULKHEAD,GREASE,STR,

Model CH9010 Hillco Leveling System
For Serial Numbers CH9010-15001 thru CH9010-15999

Undercarriage

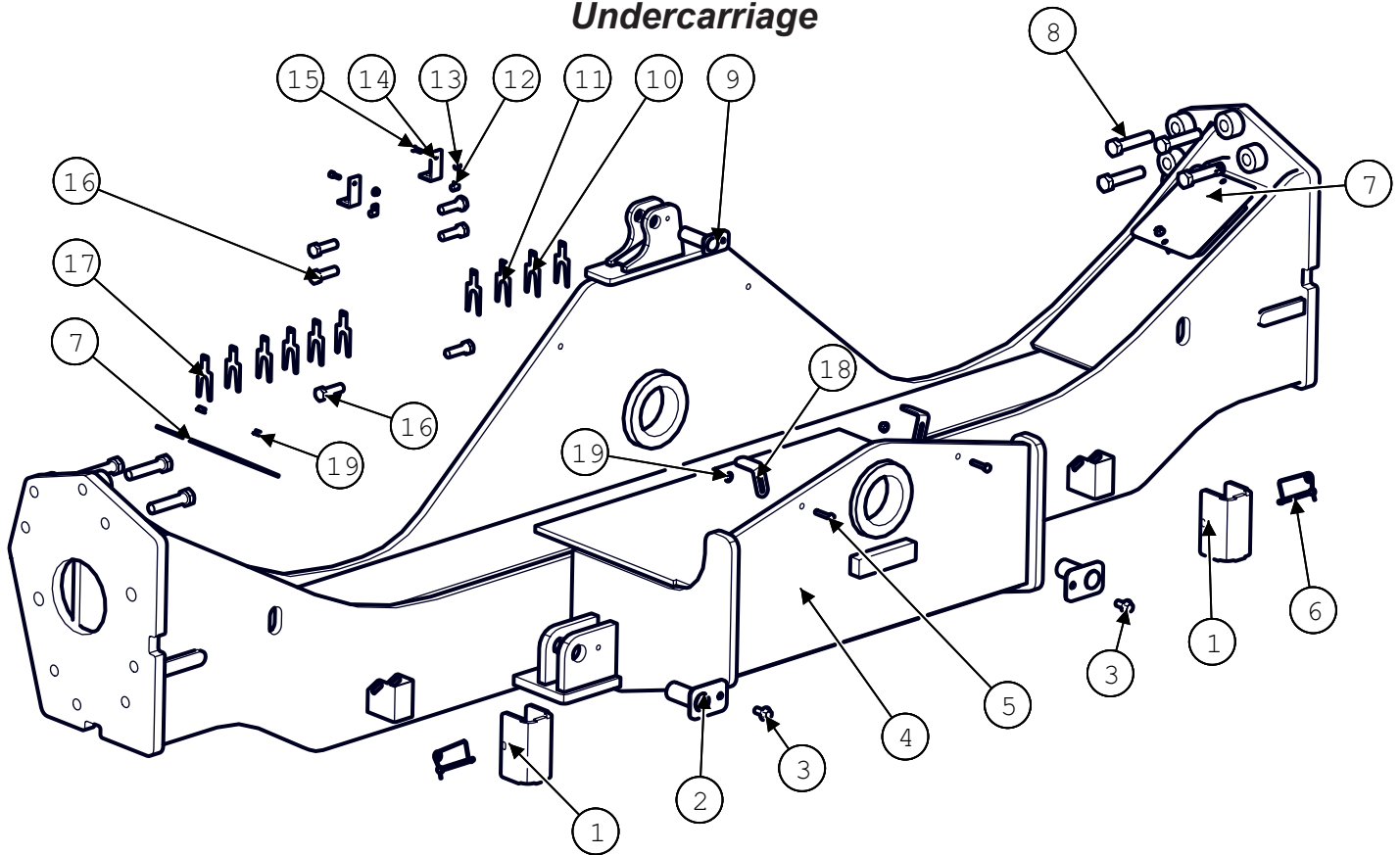

Undercarriage			
BOM ID	Part No.	Qty	Description
1	1293721	2	CYLINDER STOP
2	1230551	2	CYLINDER PIN, LEVELING
3	122.012.025	2	BOLT,HX,FL,CL10.9 M12X25
4	1251531	1	UNDERCARRIAGE
5	170.008.040	2	BOLT,HX,CL8.8 M8X40
6	146.004.048	2	PIN,SNAP,LCK
7	1251461	2	BOLT COVER, FINAL
8	121.02	16	BOLT,HX,CL10.9 M20X90
9	1229071	1	CYLINDER PIN, TRIM
10	141971	3	SHIM,ALIGNMENT,1/32"
11	141981	3	SHIM,ALIGNMENT,1/64"
12	142101	2	LOOP, CLOSED, .375", R/C
13	123.006	2	NUT,HX,FL,CL10 M6
14	1251871	2	MOUNT, BRAKE LINE
15	120.006.020	2	BOLT,HX,CL10.9 M6X20
16	121.016.050	6	BOLT,HX,CL10.9 M16X50
17	141961	6	SHIM,ALIGNMENT,1/16"
18	1251551	2	LIMIT STOP
19	123.008	6	NUT,HX,FL,CL10 M8

Model CH9010 Hillco Leveling System
 For Serial Numbers CH9010-15001 thru CH9010-15999

DROP AXLE

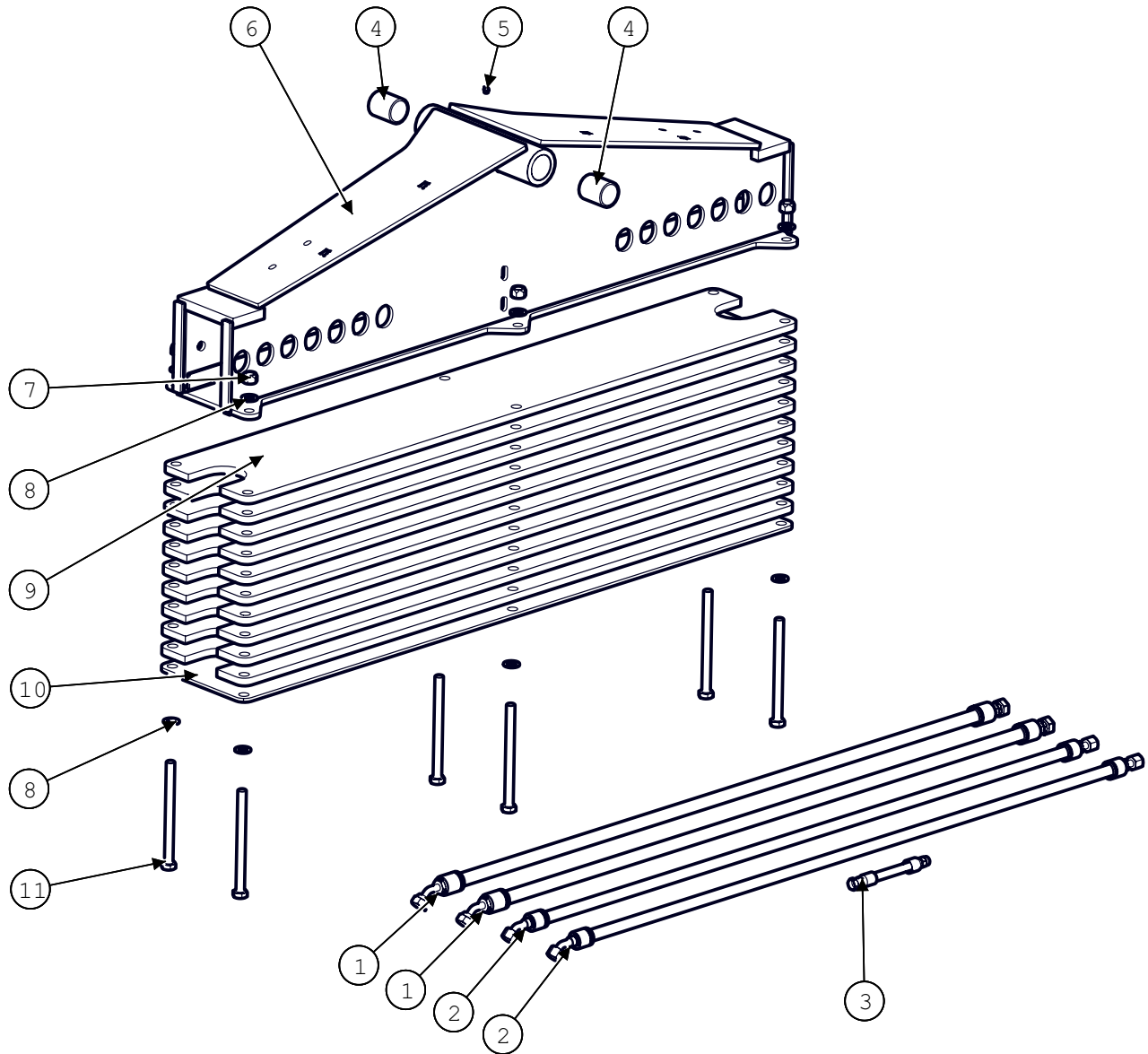

Drop Axle			
BOM ID	Part No.	Qty	Description
1	1324171	2	100R15-12 72";
2	1324181	2	100R15-10 72";
3	1325061	1	100R17AR-08 9";
4	140791	2	PIVOT SLEEVE
5	141231	1	ZERK, GREASE, 45°, 1/8
6	1252162	1	DROP AXLE
7	126.02	6	NUT,HX,STV,CL10 M20
8	133.012	12	WASHER,L9,HD 3/4
9	1285891	0-10	WEIGHT, 160LB
10	1320511	1	JACKING PLATE
11	121.020.250	6	BOLT,HX,CL10.9 M20X250

RETRACTABLE LADDER & TOP WEDGE

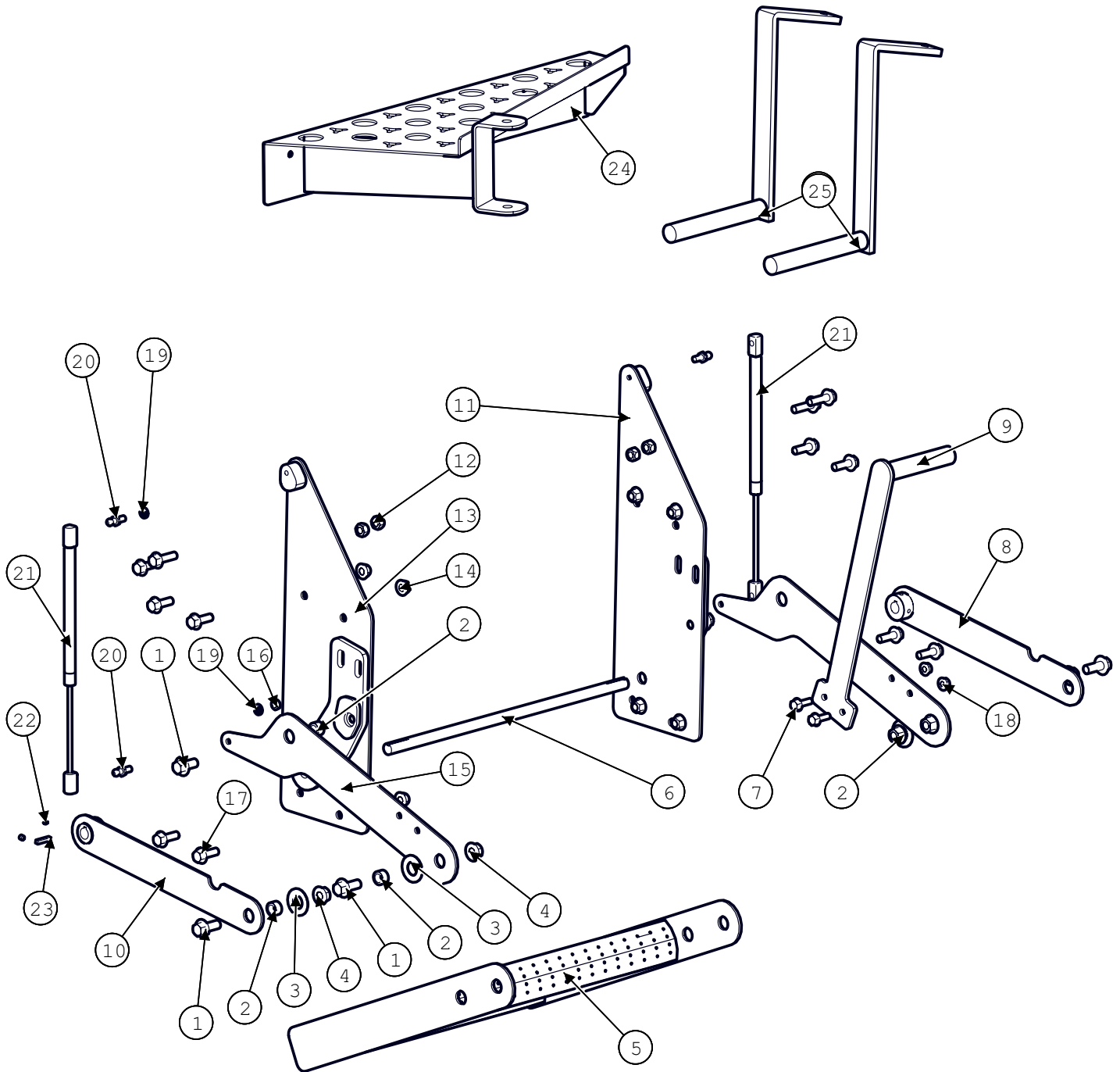

Model CH9010 Hillco Leveling System
For Serial Numbers CH9010-15001 thru CH9010-15999

Ladder			
BOM ID	Part No.	Qty	Description
1	122.012.0	6	BOLT,HX,FL,CL10.9 M12X
2	1299181	6	PIVOT BUSHING
3	153.014.012	4	BUSHING,MACH,WR
4	123.012	4	NUT,HX,FL,CL10 M12
5	1305801	1	STEP, FOLDING LADDER
6	1305861	1	ROCK SHAFT
7	122.008.025	2	BOLT,HX,FL,CL10.9 M8X25
8	1305811	1	LEFT LINK
9	1248861	1	LADDER HANDLE
10	1305821	1	RIGHT LINK
11	1305871	1	LADDER MOUNT, LEFT (-YDG218539)
	1306781		LADDER MOUNT, LEFT (YDG218540-)
12	126.01	4	NUT,HX,STV,CL10 M10
13	1305921	1	LADDER MOUNT, RIGHT (-YDG218539)
	1306791		LADDER MOUNT, RIGHT (YDG218540-)
14	128.01	8	NUT,HX,FL,STV,CL10 M10
15	1305831	2	UPPER ARM
16	174.005	2	NUT,HX,JAM,GR5 5/16-18
17	122.010.03	12	BOLT,HX,FL,CL10.9 M10X3
18	123.008	2	NUT,HX,FL,CL10 M8
19	136.005	4	WASHER,LCK,MED-SPLIT 5/16
20	134931	4	BRACKET, LIFT SUPPORT
21	139251	2	LIFT SUPPORT, GAS CHARGED,
22	166.004.004	4	SCREW,SKT,SET 1/4-28X1/4
23	10049.03.00016	2	SQ,1018,CD 3/16X1
24	1253901	1	LADDER WEDGE (-YDG218539)
	1307451	1	LADDER WEDGE (YDG218540-)
25	1251802	2	STEP SUPPORT, RIGHT

Model CH9010 Hillco Leveling System
For Serial Numbers CH9010-15001 thru CH9010-15999

LEVELING BOX

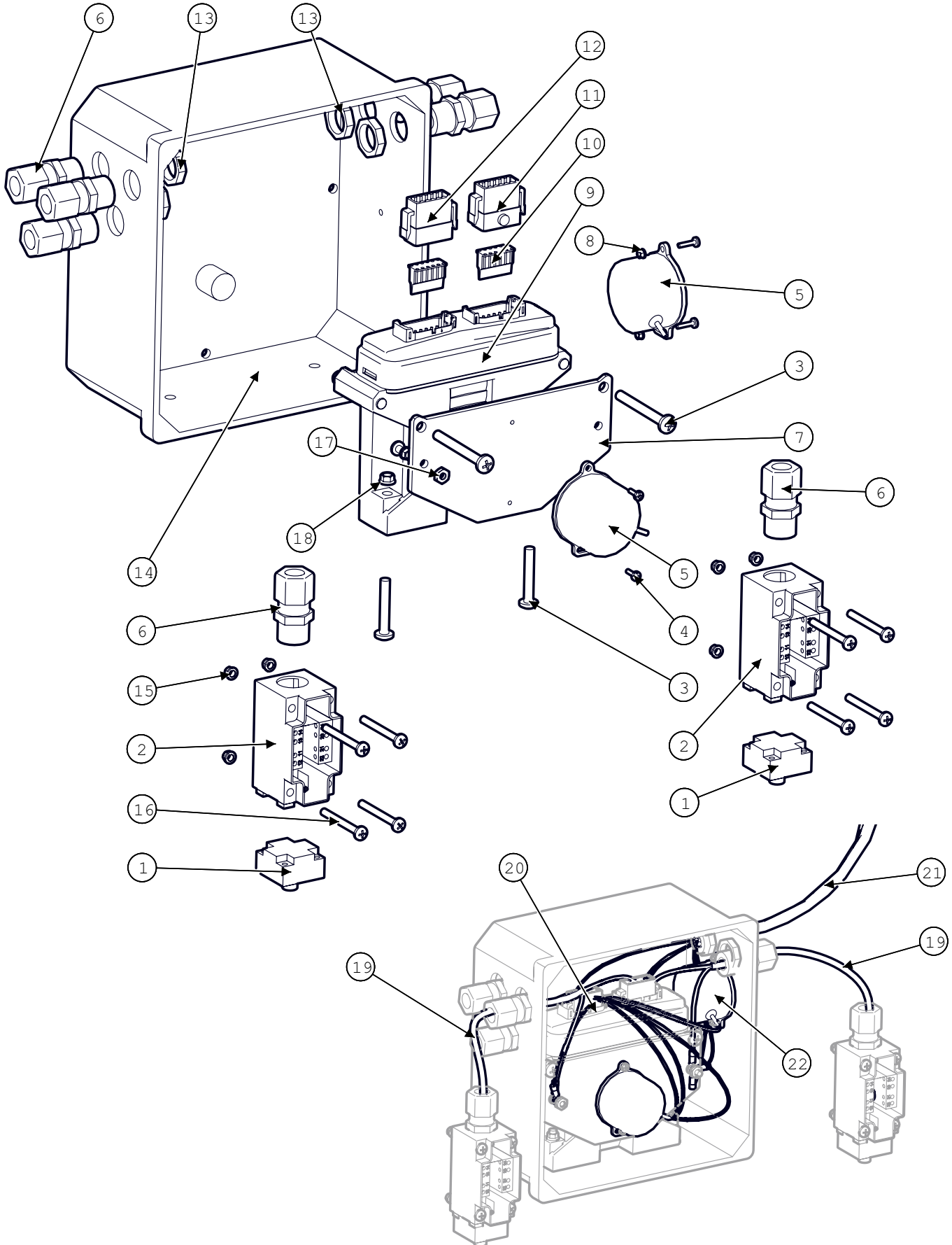

Model CH9010 Hillco Leveling System
For Serial Numbers CH9010-15001 thru CH9010-15999

Leveling Box			
BOM ID	Part No.	Qty	Description
1	100692	2	HEAD,LIMIT SWITCH,
2	100557	2	BODY, LIMIT SWITCH
3	114.004	4	SCREW,PHM,CH,SERR
4	114.#06	4	SCREW,PHM,CH 6-32X
5	141841	2	CLINOMETER, ACCUSTAR
6	138781	7	STRAIN RELIEF,BLACK,
7	1255331	1	CLINOMETER MOUNT
8	119.#06	2	NUT,HX,FL,SERR 6-32
9	141831	1	SAUR-DANFOSS CONTROLLER (PROGRAM 1260093)
10	141741	2	WEDGE,12-SOCKET,
11	141761	1	PLUG,12-SOCKET,
12	141751	1	PLUG,12-SOCKET,A-KEY
13	142121	5	NUT,STRAIN RELIEF,BLK
14	1260301	1	CA PRT, CONTROLLER BOX
15	119.#10	10	NUT,HX,FL,SERR 10-24
16	114.#10	10	SCREW,PHM,CH 10-24X
17	168.#10	2	NUT,HX 10-24
18	119.004	4	NUT,HX,FL,SERR 1/4-20
Controller Harnesses			
19	1255631	2	LIMIT SWITCH
20	1255661	1	CONTROLLER GROUND
21	1249103	1	BOX TO VALVE
22	1261191	1	CLINOMETER

MONITOR & REMOTE SWITCHES

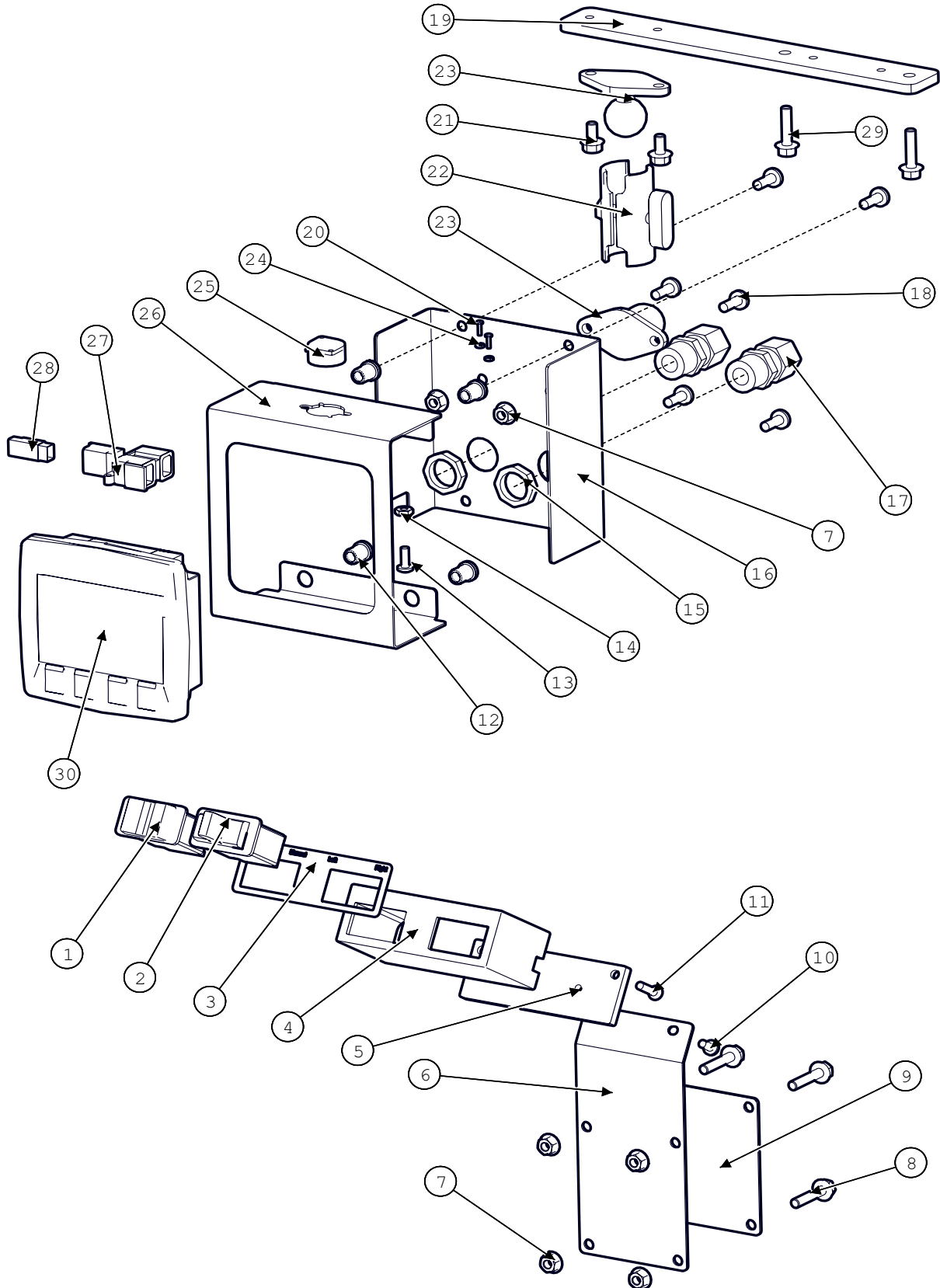

Model CH9010 Hillco Leveling System
For Serial Numbers CH9010-15001 thru CH9010-15999

Monitor & Remote Switches			
BOM ID	Part No.	Qty	Description
1	150121	1	SWITCH, ON-NONE-ON,
2	150031	1	SWITCH, (ON)-OFF-(ON),
3	150131	1	LABEL, SWITCH BOX
4	1286371	1	SWITCH BOX, REMOTE
5	1286381	1	BOX COVER,
6	1307141	1	SWITCH MOUNT
7	123.006	6	NUT,HX,FL,CL10 M6
8	122.006.030	4	BOLT,HX,FL,CL10.9 M6X30
9	1307151	1	CLAMP, SWITCH MOUNT
10	171.005.010	2	SCREW,PHM,CH M5X10
11	172.005.020	2	SCREW,FHM,CH M5X20
12	173.006	4	NUT,RIVET M6
13	114.#10.008	1	SCREW,PHM,CH 10-24X1/2
14	168.#10	1	NUT,HX 10-24
15	142121	2	NUT,STRAIN RELIEF,BLK
16	1307001	1	BOX COVER
17	138781	2	STRAIN RELIEF,BLACK,
18	171.006.016	6	SCREW,PHM,CH M6X16
19	1306981	1	MOUNT BAR, MONITOR
20	114.#02.005	2	SCREW,PHM,CH 2-56X5/16
21	122.006.012	2	BOLT,HX,FL,CL10.9 M6X12
22	153871	1	RAM, DBL SOCKET ARM FOR 1" BALL, 2" SOCKET TO SOCKET LENGTH
23	1307011	2	MOUNT BASE, MONITOR
24	168.#02	2	NUT, HX, 2-56
25	146481	1	BUZZER, PIEZO ELECTRIC
26	1306991	1	DISPLAY MOUNT
27	146531	1	Y-CONNECTOR, BLACK
28	146541	1	PLUG,GRAY,120-OHM
29	122.006.025	2	BOLT,HX,FL,CL10.9 M6X25
30	146461	1	DISPLAY, SAUER DANFOSS
Monitor Harnesses			
NS	1265791	1	BUZZER
NS	1307041	1	REMOTE SWITCH
NS	1307051	1	CAB TO BOX

ELECTRICAL HARNESSSES

Electrical Harnesses			
BOM ID	Part No.	Qty	Description
1	1249103	1	BOX TO VALVE
2	1307041	1	REMOTE SWITCH
3	1307051	1	CAB TO BOX
4	1307061	1	POWER & GROUND
5	1312991	1	LEVELING MANIFOLD

HYDRAULICS COMPONENTS

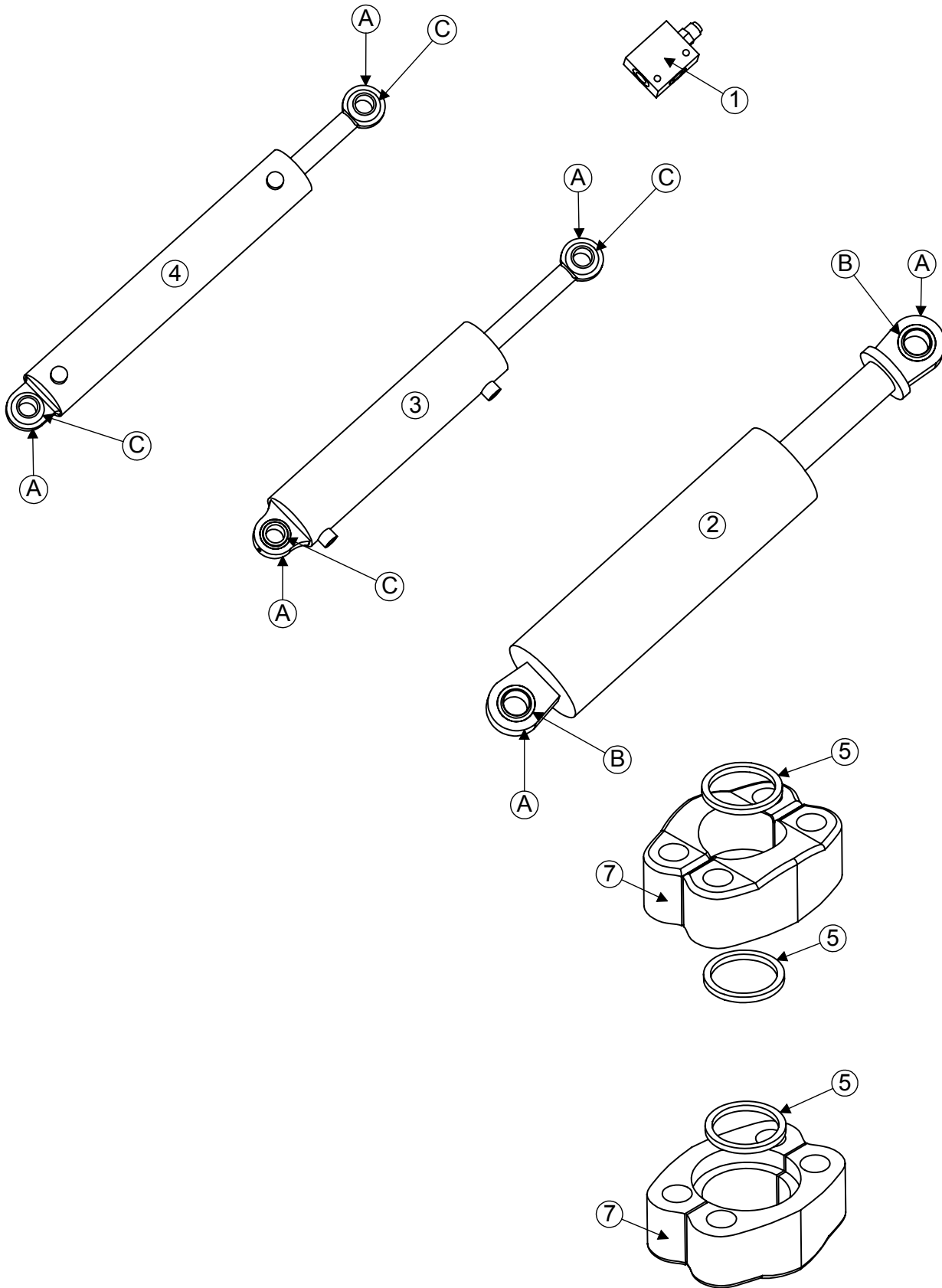

Model CH9010 Hillco Leveling System
For Serial Numbers CH9010-15001 thru CH9010-15999

COUNTERBALANCE VALVE AND CYLINDERS				
REF.	PART NO.	QTY.	PART NAME	NOTES
1	HC-139151	2	VALVE ASM, COUNTERBALANCE	
..	HC-139181	2	BODY, COUNTERBALANCE VALVE	
..	HC-139161	2	CARTRIDGE, COUNTERBALANCE VALVE	
NS	HC-140361	2	SEAL KIT, COUNTERBALANCE VALVE	
2	HC-147521	2	CYLINDER, MAIN	
NS	HC-135221	2	SEAL KIT, MAIN CYLINDER	
3	HC-147501	1	CYLINDER, MASTER	
NS	HC-134201	1	SEAL KIT, MASTER CYLINDER	
4	HC-147491	1	SLAVE CYL, 1-1/8" R, 12-1/2" S, 2-1/2 B, 21" CPC	
NS	HC-141281	1	SEAL KIT, SLAVE CYLINDER	
HYDRAULIC FASTENERS				
REF.	PART NO.	QTY.	PART NAME	WHERE USED
A	F-SSS-04F04	6	SET SCREW, 1/4-28 X 1/4	ALL CYLINDERS
B	MC-150881	4	1 3/8" BEARING, SEALED SPHERICAL	
C	MC-150871	4	1" BEARING, SEALED SPHERICAL	
CODE 62 SPLIT FLANGE CONNECTOR KIT				
REF.	PART NO.	QTY.	PART NAME	NOTES
ASM	LA-254951	2	KIT, HOSE COUPLER, 1-1/4" CODE 62	
ONE CODE 62 SPLIT FLANGE CONNECTOR KIT ASSEMBLY INCLUDES:				
5	HC-147621	3	O-RING, CODE 62, 1-1/4"	
6	HC-148301	1	HM PLT, CODE 62 (#20)	
7	LM-273011	4	HM FLANGE, CODE 62, #20	
NS	F-HC-14M090E	4	HC-10.9 M14 X 2.00 X 90 PLT	
NS	F-HNS-14ME	4	HN-10.9 M14 X 2.00 STOVER PLT	

LEVELING MANIFOLD

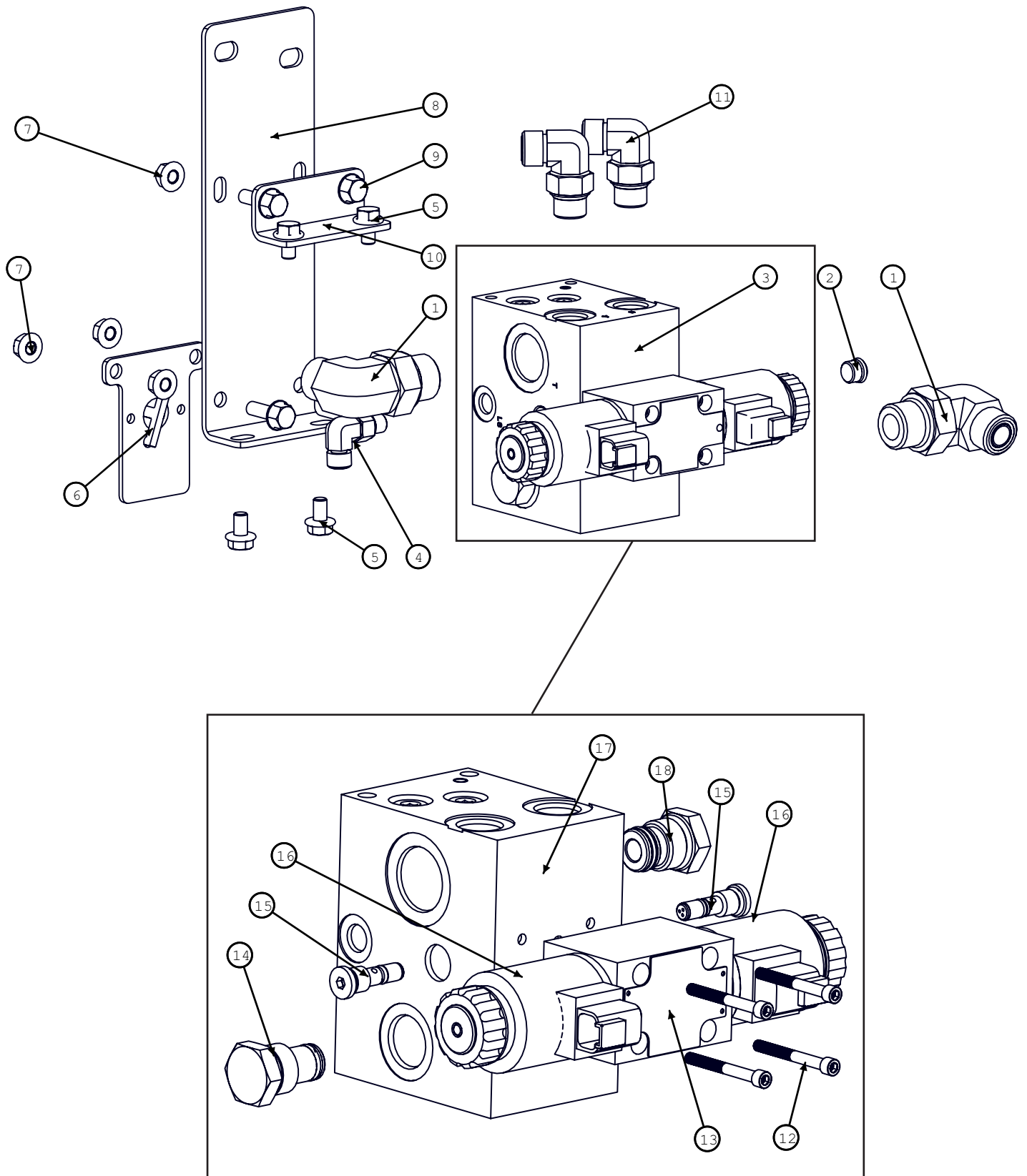

Model CH9010 Hillco Leveling System
For Serial Numbers CH9010-15001 thru CH9010-15999

MANIFOLD			
BOM ID	Part No.	Qty	Description
1	1003.12.10	2	HA: 90° -12MORB X 10MORFS
2	1019.06	1	HA:PLUG:SKT:HD -6ORB
3	1312741	1	MANIFOLD, CUSTOM, LEVELING
4	1003.04.04	1	HA, 90° -4MORB X -4MORFS
5	111.005.008	4	FLHC 5/16-18 X 1/2 SERRATED
6	1259951	1	OT WLD, MOUNT, TILT SENSOR
7	123.008	1	NUT,HX,FL,CL10 M8
8	1313221	1	OT PRT,MANIFOLD, MOUNT BASE
9	122.008.025	4	BOLT,HX,FL,CL10.9 M8X25
10	1313231	1	OT PRT,MANIFOLD MOUNT BASE
11	1003.08.08	2	HA,90° -8MORB X -8MORFS
12	196.#10.028	4	SHCS 10-24 X 1.75
13	155237	1	DIRECTIONAL VALVE,PROPORTIONAL Includes (2) 155239
14	155234	1	CAVITY PLUG, 3 WAY, 10 SERIES
15	155236	2	CHECK VALVE, REVERSE DIRECTION
16	155239	2	SOLENOID COIL,D03,PROP,DEUTSCH
17	155235	1	VALVE BODY, LEVELING
18	155238	1	CAVITY PLUG, 2 WAY, 10 SERIES

HYDRO HOSES ACCESSORIES

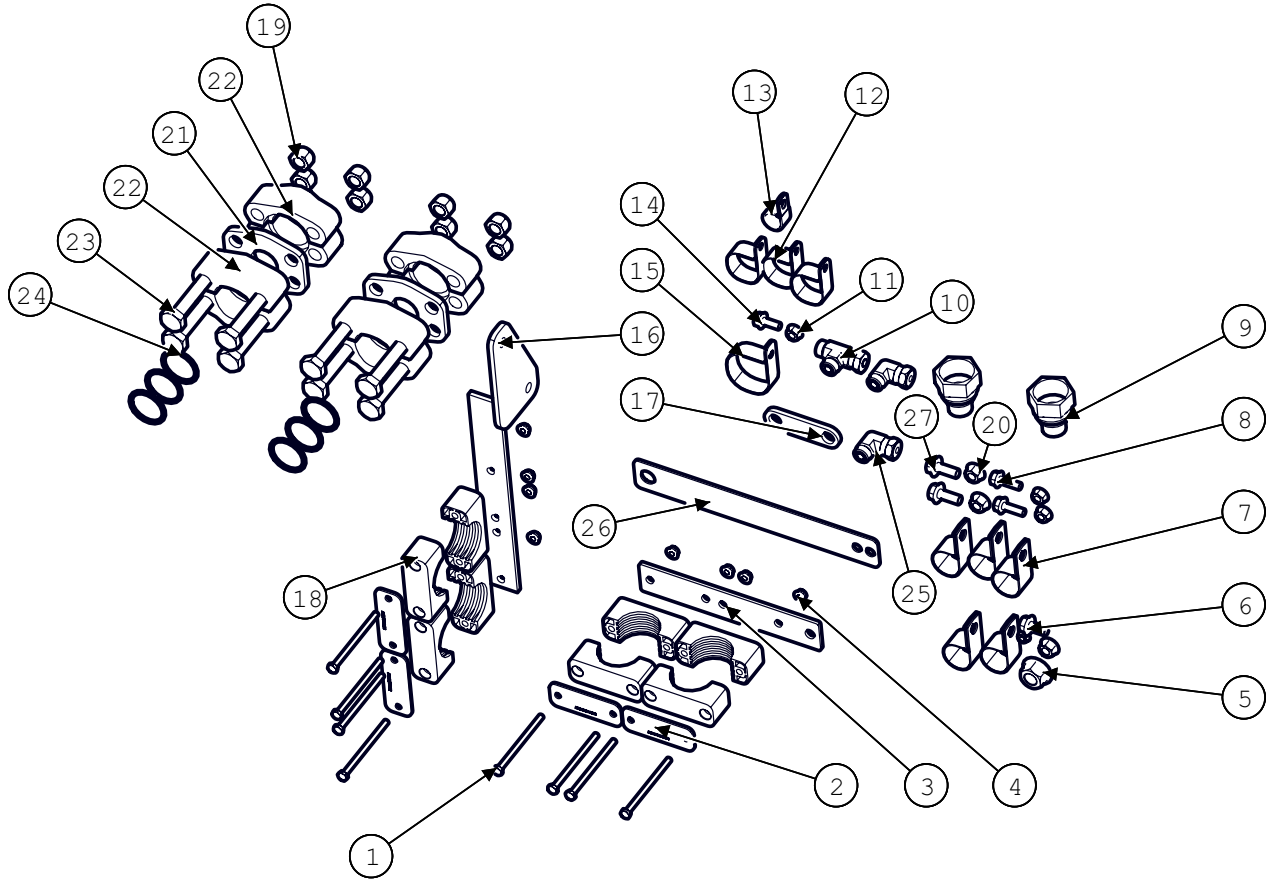

Model CH9010 Hillco Leveling System
For Serial Numbers CH9010-15001 thru CH9010-15999

Hydro Hose Accessories			
BOM ID	Part No.	Qty	Description
1	170.006.090	8	BOLT,HX,CL8.8 M6X90
2	140651	4	COVER PLATE
3	1251862	1	HYDROHOSE SUPPORT
4	123.006	9	NUT,HX,FL,CL10 M6
5	123.016	1	NUT,HX,FL,CL10 M16
6	122.010.020	1	BOLT,HX,FL,CL10.9 M10X20
7	143601	5	CLAMP, HOSE 1-1/8"
8	122.008.025	2	BOLT,HX,FL,CL10.9 M8X25
9	1004.16.10	2	HA,STR
10	1008.06	1	SWIVEL NUT, RUN, -6ORFS
11	123.008	3	NUT,HX,FL,CL10 M8
12	135631	3	CLAMP, 1-1/2" R/C W 3/8
13	135791	1	CLAMP, HOSE
14	122.008.020	1	BOLT,HX,FL,CL10.9 M8X20
15	135781	1	CLAMP, HOSE 2 R/C W/3/8 HOLE
16	1251832	1	HOSE BRACKET, HYDRO
17	1275651	1	HYDROHOSE SPREADER
18	140641	4	CLAMP, 2" BEHRINGER
19	126.014	8	NUT,HX,STV,CL10 M14
20	123.01	3	NUT,HX,FL,CL10 M10
21	1272161	2	UNION, CODE 62, 1-1/4"
22	147611	8	FLANGE, CODE 62, -20
23	121.014.090	8	BOLT,HX,CL10.9 M14X90
24	147621	6	O-RING, CODE 62
25	1006.06.06	2	-6FORFS X -6MORFS
26	1285102	1	HYDROHOSE PULL
27	122.010.025	2	BOLT,HX,FL,CL10.9 M10X25

Model CH9010 Hillco Leveling System
For Serial Numbers CH9010-15001 thru CH9010-15999

HYDRAULIC HOSES

Hydraulic Hoses				
BOM ID	Part No.	Qty	Description	Where Used
1	1133631	2	100R17AR-08 X 82",	OUTER MAIN ROD TO CB VALVE PORT #2 (RUN LEG OF TEE; LEFT & RIGHT)
2	1140521	2	100R2-04 X 14";	INNER ROD PORT TO CB VALVE PORT #3 (LEFT & RIGHT)
3	1140531	1	100R2-08 X 104",	LEVELING PORT "A" TO CB PORT #2 LEFT CYLINDER (BRANCH LEG OF TEE)
4	1140541	1	100R2-08X184-1/2,	LEVELING PORT "B" TO CB VALVE PORT #2 RIGHT CYLINDER (BRANCH LEG OF TEE)
5	1140551	1	100R15-20 82";	BOTTOM HYDROSTAT HOSE EXTENSION
6	1140561	1	100R2-04 X 116",	MASTER CYLINDER BASE PORT TO SLAVE CYLINDER BASE
7	1140571	1	100R2-04 X 138"	CONNECTS MASTER CYLINDER ROD TEE TO SLAVE CYLINDER ROD PORT
8	1140581	1	100R17AR-04 111"	HEADER TILT HOSE
9	1140591	1	100R2-04 X 104",	HEADER TILT HOSE
10	1141921	1	100R1-03 X 70",	HEADER TILT HOSE
11	1147691	1	100R15-20 78";	TOP HYDROSTAT HOSE EXTENSION
12	1319751	1	100R17AR-16 114";	EXTENDS CASE DRAIN HOSE
13	1324171	2	100R15-12 72";	REPLACES THE FORWARD PROPULSION HOSE ON THE LEFT & RIGHT RWA MOTORS
14	1324181	2	100R15-10 72";	REPLACES THE REVERSE PROPULSION HOSE ON THE LEFT & RIGHT RWA MOTORS
15	1325061	1	100R17AR-08 9";	EXTENDS CASE DRAIN HOSE ON THE LEFT RWA MOTOR
Brake Hoses				
NS	1140602	2	TITFLEX-04 83"	EXTENDS BRAKE HOSES

MISCELLANEOUS



1) LL-133741



2) LL-151061

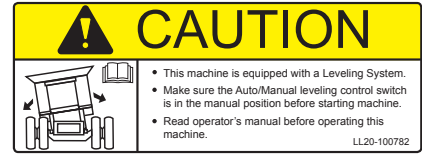

3) LL20-100782



4) LL20-100783



5) LL20-100784



6) LL20-100785



7) LL20-100786

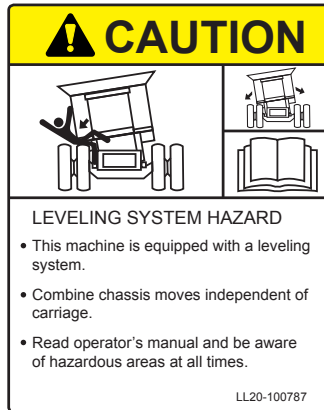

8) LL20-100787



9) LL20-100788

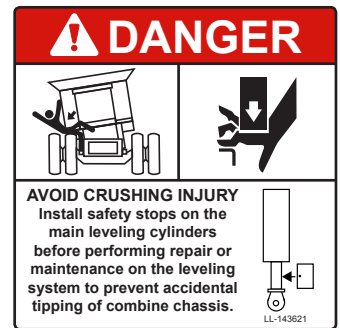

10) LL-143621



11) LL-141012

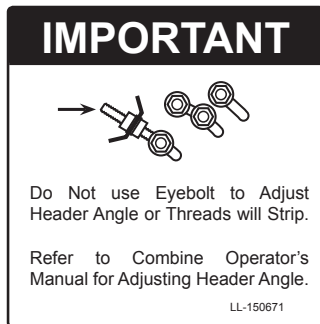

12) LL-150571

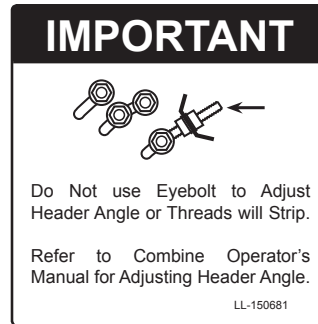

13) LL-150581

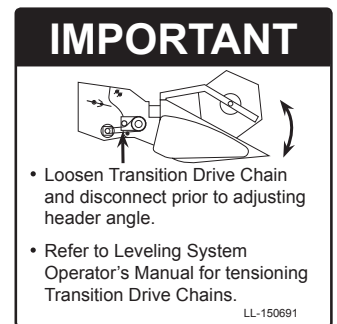

14) LL-150591

Model CH9010 Hillco Leveling System
For Serial Numbers CH9010-15001 thru CH9010-15999

DOCUMENTS AND LABELS				
REF.	PART NO.	QTY.	PART NAME	NOTES
1	LL-133741	2	LABEL, GREASE 50 HR	RH AND LH MAIN LEV CYL BOTTOM
1	LL-133741	1	LABEL, GREASE 50 HRS	BY BASE END OF SLAVE CYLINDER
1	LL-133741	2	LABEL, GREASE 50 HRS	REAR FACE 12" ON BOTH SIDES OF PIVOT PIN
1	LL-133741	2	LABEL, GREASE 50 HRS	RH AND LH BULKHEAD MOUNT
2	LL-153631	2	DECAL, CASE HILLSIDE LEVELING SYSTEM (20 YEAR ANNIVERSARY)	SIDE PANELS ON COMBINE
3	LL20-100782	1	CAUTION LEVELING SYSTEM CAB	WINDOW IN CAB
4	LL20-100783	2	DANGER, CRUSHING HAZARD	FRONT UC LEFT & RIGHT
4	LL20-100783	2	DANGER CRUSHING HAZARD	SIDE OF COMBINE ABOVE REAR TIRES
5	LL20-100784	2	DANGER PINCH POINT	RH & LH UPPER TRANS FACE PLT
6	LL20-100785	1	CAUTION MOVING STEP	COMBINE LADDER CHANNEL
7	LL20-100786	1	WARNING, ELECTRONIC CRUSHING HAZARD	FRONT OF CONTROL BOX
8	LL20-100787	2	CAUTION LEVELING SYSTEM HAZARD	CLEAN GRAIN ELEVATOR (RH); SCREEN (LH)
9	LL20-100788	3	DANGER HYDRAULIC HAZARD	1- EA MAIN CYLINDER
9	LL20-100788	1	DANGER HYDRAULIC HAZARD	ABOVE HYDRAULIC MANIFOLD
10	LL-143621	2	DANGER, AVOID CRUSHING INJURY	REAR OF UC NEAR THE SAFETY STOP MNTS
11	LL-141012	2	DECAL, ROCK TRAP WARNING	BY ROCK TRAP HANDLE AND ON SHIELD ABOVE HANDLE
12	LL-150671	1	LABEL, EYEBOLT LEFT	BELOW LEFT EYEBOLT MOUNT
13	LL-150681	1	LABEL, EYEBOLT RIGHT	BELOW RIGHT EYEBOLT MOUNT
14	LL-150691	1	LABEL, HEADER ANGLE	ON RH SIDE TT ASM NEAR TOP ADJ BOLTS
NS	EC-150131	1	DECAL, REMOTE SWITCH BOX	
NS	LL-141011	2	DECAL, ROCK TRAP WARNING	BY ROCK TRAP HANDLE AND ON SHIELD ABOVE HANDLE
NS	LL-239412	1	LABEL, STEERING WHEEL	TIED TO STEERING WHEEL DURING INSTALLATION
NS	LL-274401	1	LABEL, LIMIT SWITCH WARNING	LIMIT SWITCH
NS	LA-255951	1	PLATE, SERIAL NUMBER	LEFT REAR OF UNDERCARRIAGE
NS	D-111212CMA01A	1	CH9010 OPERATORS MANUAL	SN 15001-15999

Model CH9010 Hillco Leveling System
For Serial Numbers CH9010-15001 thru CH9010-15999

Hillco Technologies, Inc.
107 1st Avenue
Nezperce, Idaho 83543

Phone	800-937-2461
	208-937-2461
Fax	208-937-2280

www.hillcotechnologies.com
email: support@hillcotechnologies.com