



# **Model 3700S Sidehill Leveling System Parts Manual**

SN 3700S-1601 thru 3700S-1699

For Case IH 5088, 6088,  
and 7088 Combines

D-110602CMA01

# Table of Contents

<b>General Information</b>	<b>2</b>
Serial Number Location	2
Text and Illustrations	2
Abbreviations	2
Right and left Identification	2
Part Orders	2
<b>Transition</b>	<b>3</b>
Transition With Header Adapter For Newer Style Heads	3
Transition With Header Adapter For Older Style Heads	5
Transition Fasteners	7
<b>Carriage</b>	<b>9</b>
Carriage Fasteners	11
<b>Drop Axle</b>	<b>13</b>
<b>Optional Ladder</b>	<b>14</b>
<b>Electrical</b>	<b>15</b>
Electrical Connectors and Cables	17
<b>Hydraulics</b>	<b>19</b>
Hydraulic Manifold	21
Hydraulic Hoses	23
Hydraulic Adapters	24
<b>Miscellaneous</b>	<b>25</b>

Model 3700S Hillco Leveling System  
For Serial Numbers 3700S-1601 thru 3700S-1699

Hillco Technologies, Inc.  
107 1st Avenue  
Nezperce, Idaho 83543

Phone	800-937-2461
	208-937-2461
Fax	208-937-2280

[www.hillcotechnologies.com](http://www.hillcotechnologies.com)  
email: [support@hillcotechnologies.com](mailto:support@hillcotechnologies.com)

## **General Information**

### **Serial Number Location**

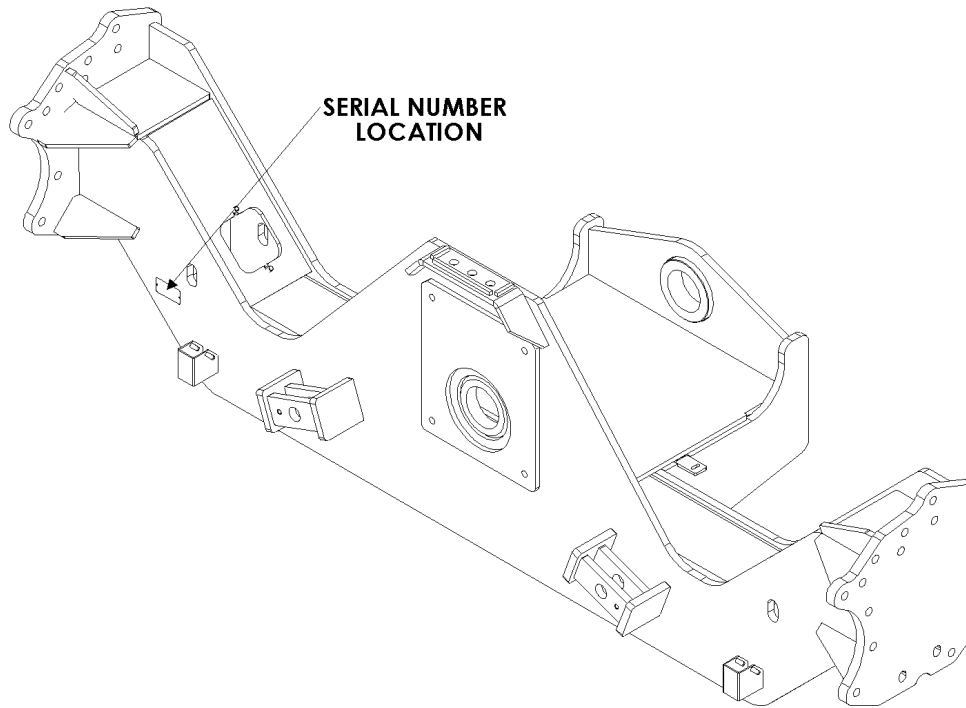

### **Text and Illustrations**

The arrangement of this parts catalog is for easy identification of parts. All parts are illustrated in exploded views in proper relation to each other. Some diagrams refer to other pages for further information. Reference numbers used in the illustrations refer to line numbers in the part lists. The part lists appear to the right or below all diagrams and correspond with those diagrams. Included in the part lists, along with the reference numbers are part numbers, part descriptions and the quantity of the part required per leveling system.

### **Abbreviations**

**SN** “Serial Number” refers to the serial number given to each leveling system (by Hillco Technologies), as well as the serial number given to the combine (by the specific combine manufacturer) the leveling system is installed. See above for the leveling system’s serial number location. This abbreviation is used interchangeably in both instances. Each Model 3700S Leveling System uses the following serial number format: 3700S-XXXX (sequential numbers).

**ASM** “Assembly” refers to a whole grouping of parts (shown in the diagram corresponding with the page where “ASM” is shown unless otherwise noted). Some assemblies have parts that are sold separately, however some must be purchased as a single unit. Hillco Product Specialists will be able to assist you with any questions.

**NS** “Not Shown” refers to a part that is not depicted in the illustration.

### **Right and left Identification**

The reference to right-hand and left-hand in this catalog is identified by the operator sitting in the operator’s seat, looking toward the front of the machine (in normal forward travel).

### **Part Orders**

Orders must specify product model, serial number, correct part number, complete description, quantity required, method of shipment, shipping address, and billing address.

***Transition With Header Adapter For Newer Style Heads***

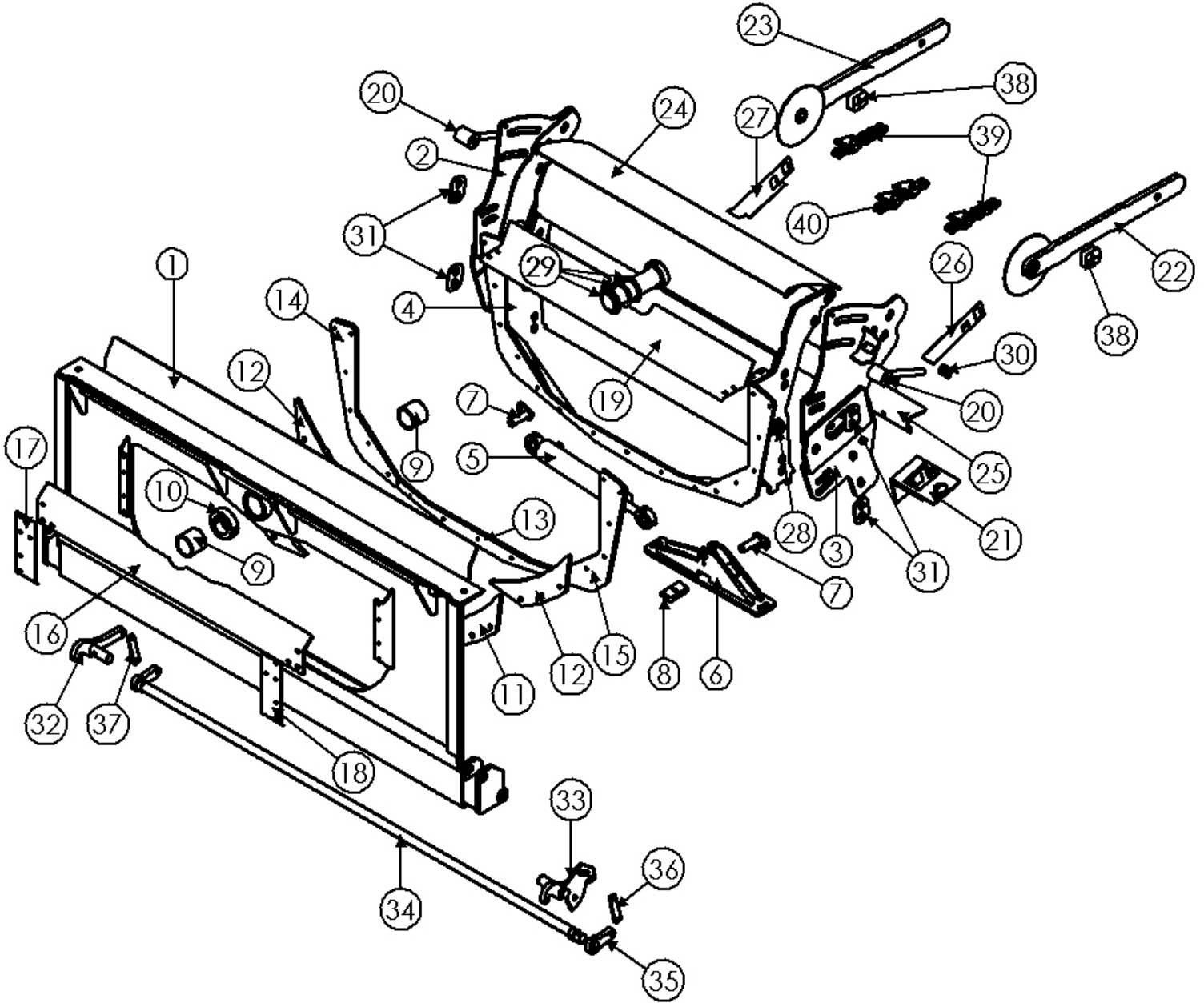

Model 3700S Hillco Leveling System  
For Serial Numbers 3700S-1601 thru 3700S-1699

TRANSITION COMPONENTS WITH HEADER ADAPTER FOR NEW STYLE HEADS				
REF.	PART NO.	QTY.	PART NAME	NOTES
ASM	LA-273631	1	TRANSITION COMPLETE ASM	
1	LA-273521	1	TA ASM	FOR 2010/2020 PLATFORMS; 2400/3400 CORN HEADS; 2016 P/U HEADS
2	LA-273651	1	TT ASM, REAR RIGHT	
3	LA-273641	1	TT ASM, REAR LEFT	
4	LA-272441	1	TT ASM, FRONT	
5	HC-138582	1	CYLINDER, SLAVE	
6	LM-273601	1	TA ASM, SLAVE CYL ROD MOUNT	
7	LA-229071	2	TM PIN ASM, TRIM CYLINDER	
8	LM-277281	1	TM PLATE, ROD MNT NUT	
9	LTP-241721	2	BUSHING, PIVOT	
10	LM-226841	1	TM COLLAR, PIVOT	
11	LP-273741	2	TM UHMW, BACKING WEAR PAD	
12	LP-272451	2	TM PLATE, BACKING	
13	LM-272461	1	TM PLATE, WEAR BOTTOM	
14	LM-272481	1	TM PLATE, WEAR RH	
15	LM-272471	1	TM PLATE, WEAR LH	
16	LP-273201	1	TM PLATE, TOP SHIELD	
17	LP-273211	1	TM PLATE, RIGHT SHIELD	
18	LP-273221	1	TM PLATE, LEFT SHIELD	
19	LP-273431	1	TM PLT, UPPER SHIELD	
20	LA-273731	2	TM ASM, ADJUSTER BOLT	
21	LA-272531	1	TM ASM, COUPLER MOUNT	
22	LA-273331	1	TM ASM, FEEDER DRUM LFT	
23	LA-273371	1	TM ASM, FEEDER DRUM RT	
24	LA-273381	1	TM ASM, TOP COVER	
25	LP-273411	1	TM PLATE, FLEX FLOOR	
26	LP-273491	1	TM SEAL, FLEX FLOOR LEFT	
27	LP-273501	1	TM SEAL, FLEX FLOOR RIGHT	
28	LM-260821	2	TM BUSHING, PIVOT OUTER	
29	F-MB-14NR40	6	BUSHING, MACH 14 GA, NR, 2-1/2 ID	
30	LM-273691	2	TM PIVOT, FORE-AFT ADJUSTER	
31	LP-273421	4	TM PLATE, LOWER WASHER	
NS	MC-143591	6	SPRING, COMPRESSION	
32	LA-270251	1	TM ASM, RH HDR LATCH	
33	LA-270261	1	TM ASM, LH HDR LATCH	
34	LA-270272	1	TM ASM, HDR LATCH CROSS SHAFT	
35	LM-270191	1	TM ARM, RH LOWER PIVOT	
36	LM-270201	1	TM LINKAGE, LH HDR LOCK	
37	LM-270211	1	TM LINKAGE, RH HDR LOCK	
38	LM-273511	2	TM STOP, FEEDER DRUM BOTTOM	
FEEDER HOUSE BEATER DRIVE				
39	LM-272951	2	FDR CHAIN EXTENTION, OUTER	557 FEEDER CHAIN EXTENSION
40	LM-272961	1	FDR CHAIN EXTENTION, INNER	557 FEEDER CHAIN EXTENSION
NS	MC-147701	3	CONNECTING LINK, FEEDR CHAIN	557 FEEDER CHAIN EXTENSION
NS	MC-147711	3	OFFSET LINK, FEEDR CHAIN	557 FEEDER CHAIN EXTENSION
NS	MC-147721	1	CONVEYOR SLAT, RIGHT HANDED W/ HARDWARE	FEEDER CHAIN
NS	MC-147731	1	CONVEYOR SLAT, LEFT HANDED W/ HARDWARE	FEEDER CHAIN

***Transition With Header Adapter For Older Style Heads***

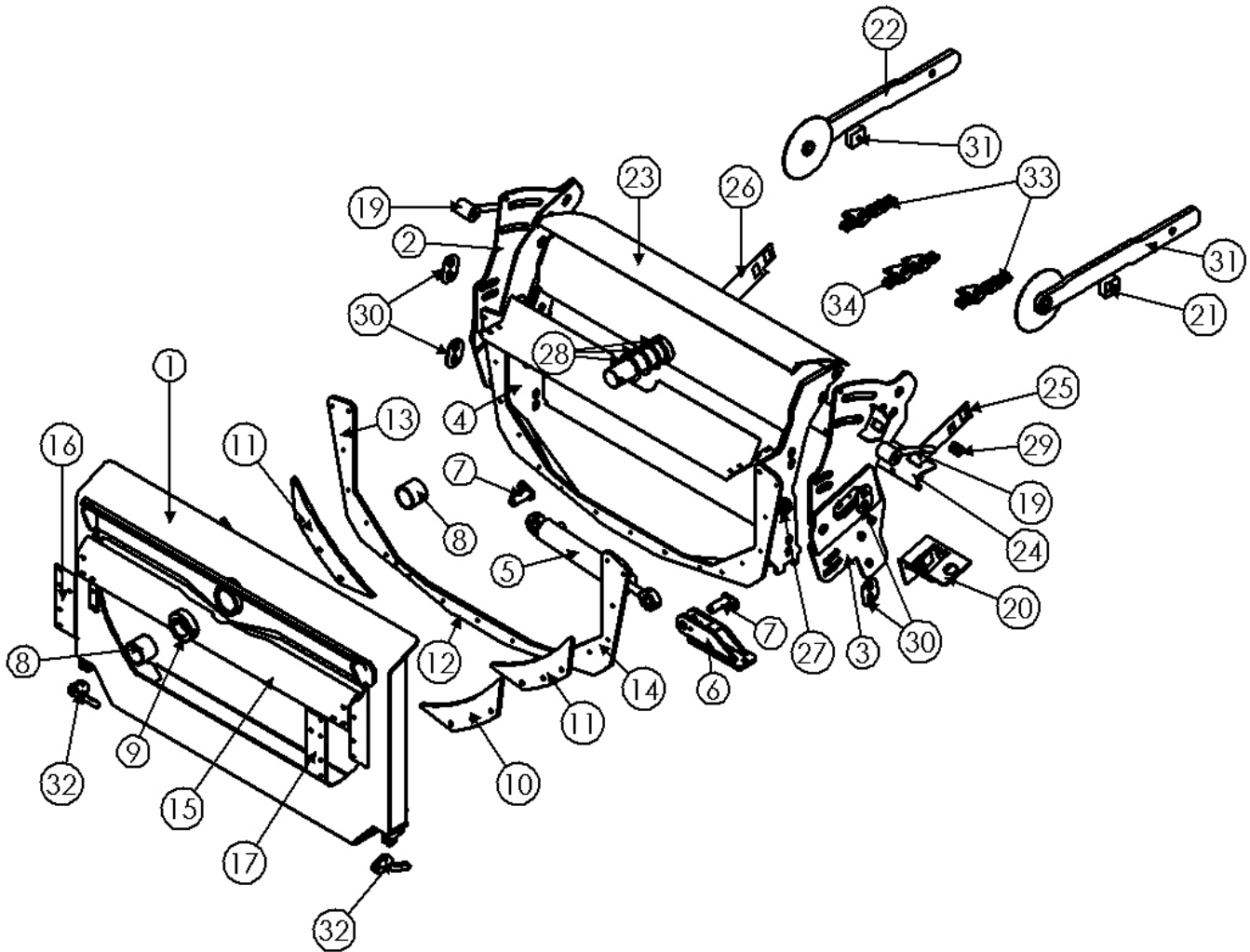

Model 3700S Hillco Leveling System  
For Serial Numbers 3700S-1601 thru 3700S-1699

<b>TRANSITION COMPONENTS WITH HEADER ADAPTER FOR OLD STYLE HEADS</b>				
REF.	PART NO.	QTY.	PART NAME	NOTES
ASM	LA-273631	1	TRANSITION COMPLETE ASM	
1	LA-273141	1	TA ASM	FOR1010/1020 PLATFORMS; 1000/2200/3200 CORN HEADS; 1015/2015 P/U HEADS
2	LA-273651	1	TT ASM, REAR RIGHT	
3	LA-273641	1	TT ASM, REAR LEFT	
4	LA-272441	1	TT ASM, FRONT	
5	HC-138582	1	CYLINDER, SLAVE	
6	LA-273271	1	TM ASM, SLAVE CYL ROD MNT	
7	LA-229071	2	TM PIN ASM, TRIM CYLINDER	
8	LTP-241721	2	BUSHING, PIVOT	
9	LM-226841	1	TM COLLAR, PIVOT	
10	LP-273741	2	TM UHMW, BACKING WEAR PAD	
11	LP-272451	2	TM PLATE, BACKING	
12	LM-272461	1	TM PLATE, WEAR BOTTOM	
13	LM-272481	1	TM PLATE, WEAR RH	
14	LM-272471	1	TM PLATE, WEAR LH	
15	LP-273201	1	TM PLATE, TOP SHIELD	
16	LP-273211	1	TM PLATE, RIGHT SHIELD	
17	LP-273221	1	TM PLATE, LEFT SHIELD	
18	LP-273431	1	TM PLT, UPPER SHIELD	
19	LA-273731	2	TM ASM, ADJUSTER BOLT	
20	LA-272531	1	TM ASM, COUPLER MOUNT	
21	LA-273331	1	TM ASM, FEEDER DRUM LFT	
22	LA-273371	1	TM ASM, FEEDER DRUM RT	
23	LA-273381	1	TM ASM, TOP COVER	
24	LP-273411	1	TM PLATE, FLEX FLOOR	
25	LP-273491	1	TM SEAL, FLEX FLOOR LEFT	
26	LP-273501	1	TM SEAL, FLEX FLOOR RIGHT	
27	LM-260821	2	TM BUSHING, PIVOT OUTER	
28	F-MB-14NR40	6	BUSHING, MACH 14 GA, NR, 2-1/2 ID	
29	LM-273691	2	TM PIVOT, FORE-AFT ADJUSTER	
30	LP-273421	4	TM PLATE, LOWER WASHER	
31	LM-273511	2	TM STOP, FEEDER DRUM BOTTOM	
NS	MC-143591	6	SPRING, COMPRESSION	
32	LP-213291	2	TM ARM, HEADER LOCK	
<b>FEEDER HOUSE BEATER DRIVE</b>				
33	LM-272951	2	FDR CHAIN EXTENTION, OUTER	557 FEEDER CHAIN EXTENSION
34	LM-272961	1	FDR CHAIN EXTENTION, INNER	557 FEEDER CHAIN EXTENSION
NS	MC-147701	3	CONNECTING LINK, FEEDR CHAIN	557 FEEDER CHAIN EXTENSION
NS	MC-147711	3	OFFSET LINK, FEEDR CHAIN	557 FEEDER CHAIN EXTENSION
NS	MC-147721	1	CONVEYOR SLAT, RIGHT HANDED W/ HARDWARE	FEEDER CHAIN
NS	MC-147731	1	CONVEYOR SLAT, LEFT HANDED W/ HARDWARE	FEEDER CHAIN
<b>OPTIONAL FOR 1010/1020 PLATFORMS; 1000/2200/3200 SERIES CORN HEADS; 1015/2015 P/U HEADS</b>				
NS	LA-273611	1	TRANSITION	
NS	LA-273141	1	TA ASM	
NS	LA-273271	1	TM ASM, SLAVE CYL ROD MNT	
NS	F-PCL-10X24	2	PIN, CLEVIS, 5/8 X 1-1/2 Pit	HEADER LOCK ARM
NS	F-PCT-02X16	2	PIN, COTTER, 1/8 X 1	HEADER LOCK ARM





Model 3700S Hillco Leveling System  
For Serial Numbers 3700S-1601 thru 3700S-1699

<b>TRANSITION FASTENERS</b>				
<b>REF.</b>	<b>PART NO.</b>	<b>QTY.</b>	<b>PART NAME</b>	<b>WHERE USED</b>
A	F-HC-16M120E	1	HC-10.9 M16 X 2.00 X 120 PLT	TT PIVOT PIN COLLAR
A	F-HNS-16ME	1	HN-10.9 M16 X 2.00 STV PLT	TT PIVOT PIN COLLAR
B	F-HCF-16M040E	3	HC-10.9 M16 X 2.00 X 35 PV PLT	ROD MNT
B	F-HNS-16ME	3	HN-10.9 M16 X 2.00 STV PLT	ROD MNT
C	F-FHS-8M030E	17	FHSC-10.9 M8 X 1.25 X 30 PLT	UHMW FACE PLT
C	F-HNS-08ME	17	HN-10.9 M8 X 1.25 STV PLT	UHMW FACE PLT
D	F-HCF-12M040E	6	FLHC-10.9 M12 X 1.75 X 40 PLT	BACKING PLATES
E	F-HCF-10M020E	2	MM FLHC-10.9 M10 X 1.50 X 20 PLT	SLAVE CYLINDER MOUNT PIN
F	F-SSS-04F04	2	SET SCREW, 1/4-28 X 1/4	SLAVE CYLINDER SPHERICAL BEARINGS
G	F-HCF-8M020E	6	FLHC- 10.9 M8 X 1.25 X 20 PLT	FRONT SHIELDS
G	F-HCF-08M025E	4	FLHC- 10.9 M8 X 1.25 X 25 Plated	TOP (4) FRONT SHIELD BOLTS
G	F-HNSF-08ME	12	FLHN-10.9 M8 X 1.25 STOVER	FRONT SHIELDS
H	F-CB-8M020F	4	CARR-8.8 M8 X 1.25 X 20	INNER THROAT SHIELD
H	F-HNSF-08ME	4	FLHN-10.9 M8 X 1.25 STV	INNER THROAT SHIELD
I	F-HCF-8M030E	2	FLHC-10.9 M8 X 1.25 X 30 PLT	TOP COVER SHIELD
J	F-CB-10M050F	6	CARR-8.8 M10 X 1.50 X 50	FLEX FLOOR HINGE
J	F-HNN-10MF	6	HN-8.8 M10 X 1.50 NYLOCK	FLEX FLOOR HINGE
K	F-HCF-16M040E	2	FLHC-10.9 M16 X 2.00 X 40	FORE/AFT PIVOT BUSHING
K	F-FWH-10	2	FW 5/8 HD PLT	FORE/AFT PIVOT BUSHING
L	F-HNF-12C	12	FLHN-8 3/4-10	ALL FORE/AFT PIVOT NUTS
M	F-CB-12C40	6	CARR 3/4-10 X 2-1/2 GR8	2 UPPER AND 4 LOWER FORE/AFT PIVOT BOLTS
N	F-CB-12C48	4	CARR 3/4-10 X 3 GR8	4 MIDDLE FORE/AFT PIVOT BOLTS
O	F-CB-12C80	2	CARR 3/4-10 X 5 GR8	2 FORE/AFT PIVOT BOLTS WITH ADJUSTER
O	F-HNF-20ME	2	FLHN-10.9 M20 X 2.50 PLT	FORE/AFT ADJUSTER BOLT
O	F-HNJ-20ME	2	HN-8.8 M20 X 2.50 JAM	FORE/AFT ADJUSTER BOLT
P	F-FWH-12	4	FW 3/4 HD PLT	4 UPPER FORE/AFT PIVOT BOLTS
NS	F-HNS-08ME	2	HN-10.9 M8 X 1.25 STV PLT	TOP COVER ASM
NA	F-HC-08M025F	2	HC-8.8 M8 X 1.25 X 25	TOP COVER ASM
<b>ADDITIONAL FASTENERS FOR NEW STYLE HEADER ADAPTER</b>				
Q	F-HCF-10M040E	4	FLHC-10.0 M10 X 1.50 X 40	LINKAGE TO LOWER PIVOT AND LOCK ARM
R	F-HNSF-10ME	4	FLHN-10.9 M10 X 1.50 STOVER	LINKAGE TO LOWER PIVOT AND LOCK ARM
S	F-PR-06X32	3	PIN, ROLL, 3/8 X 2 Plated	HEADER LOCK LINKAGE
T	F-MB-18NR20	6	BUSHING, MACH 18 GA NR, 1-1/4 ID	HEADER LOCK LINKAGE
U	F-MB-18NR24	4	BUSHING, MACH 18 GA NR 1-1/2 ID	HEADER LOCK LINKAGE
<b>ADDITIONAL FASTENERS FOR OLD STYLE HEADER ADAPTER</b>				
V	F-PCL-16X32	2	PIN, CLEVIS, 1 X 2 Pit	HEADER LOCK ARM
V	F-PCT-03X32	2	PIN, COTTER, 3/16 X 2	HEADER LOCK ARM

Model 3700S Hillco Leveling System  
For Serial Numbers 3700S-1601 thru 3700S-1699

**Carriage**

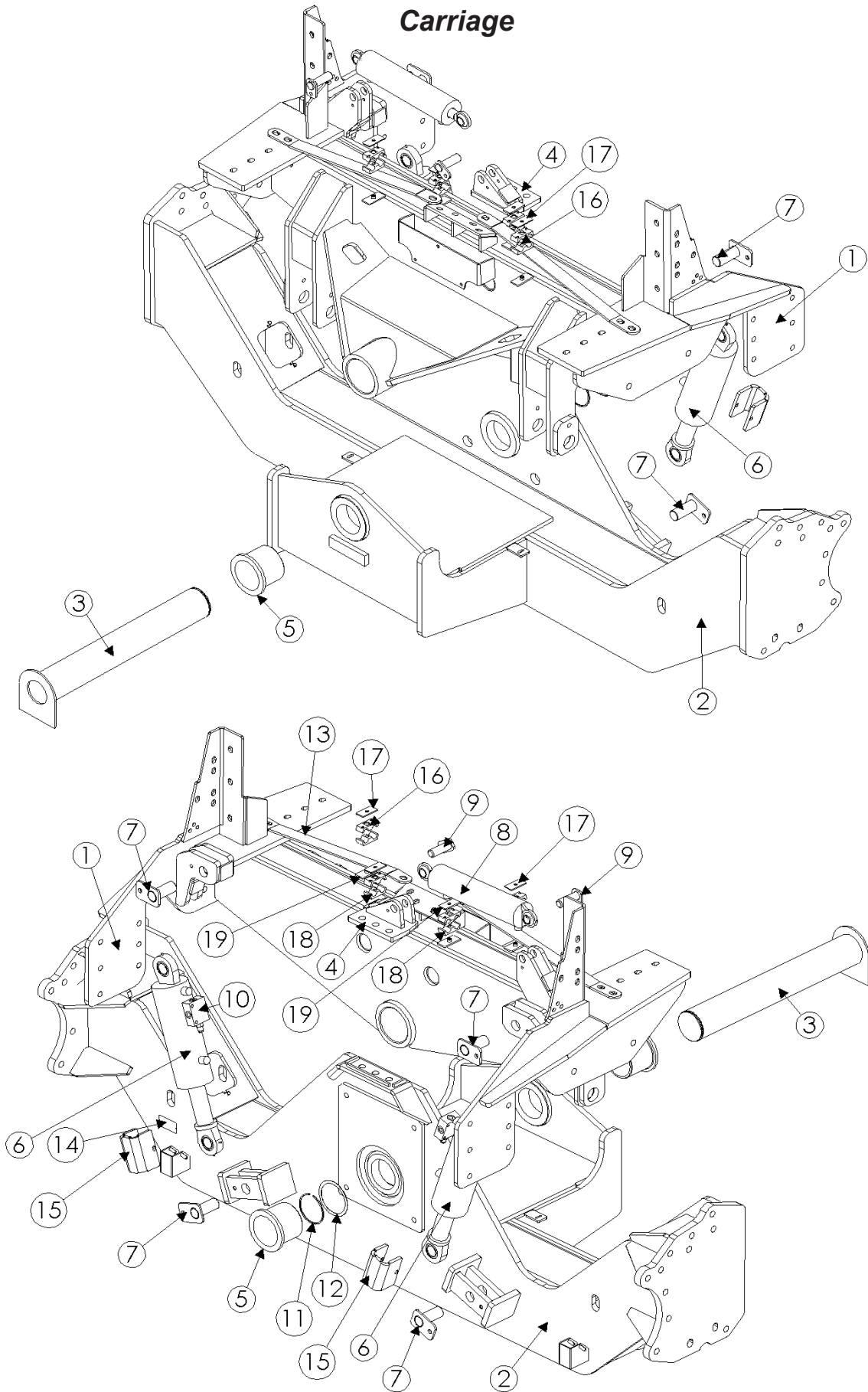

Model 3700S Hillco Leveling System  
For Serial Numbers 3700S-1601 thru 3700S-1699

<b>CARRIAGE COMPONENTS</b>				
<b>REF.</b>	<b>PART NO.</b>	<b>QTY.</b>	<b>PART NAME</b>	<b>NOTES</b>
ASM	LA-272131	1	OC/UC COMPLETE ASM	
1	LA-271042	1	CO ASM	
2	LA-271061	1	CU ASM	
3	LA-267021	1	CM ASM, MAIN PVT PIN	
4	LM-272591	1	CM ASM, MSTR CYL ROD MOUNT	
5	LP-247961	2	CM BUSHING, PIVOT	
6	HC-140313	2	CYLINDER, MAIN	
7	LA-230551	4	CM PIN ASM, MAIN CYLINDER	
8	HC-140342	1	CYLINDER, MASTER	
9	LA-229071	2	TM PIN ASM, TRIM CYLINDER	
10	HC-138901	2	VALVE, 3-PORT COUNTERBALANCE	MAIN LEVELING CYLINDERS BASE END
11	MC-138651	1	SNAP RING 4"	
12	MC-138641	4	WASHER	
13	LP-267041	2	CM STRAP, X-BRACE	
14	LA-270031	1	TAG, SERIAL NUMBER 3700S	
15	LP-252241	2	LM PLATE, CYLINDER STOP	
<b>OPTIONAL-SAFETY STOPS</b>				
NS	MC-137251	?	COLLAR, 2-PIECE CLAMPING W/ 2" BORE	
NS	MC-137501	?	WASHER, QUICK REPAIR 2"	
<b>MISCELLANEOUS CARRIAGE COMPONENTS</b>				
<b>REF.</b>	<b>PART NO.</b>	<b>QTY.</b>	<b>PART NAME</b>	<b>NOTES</b>
16	HC-139431	2	BEHRINGER TWIN CLAMP .750 DIAMETER	
17	HC-139451	2	BEHRINGER TWIN COVER PLATE (FOR .750)	
NS	LA-272861	1	CU MOUNT, EXTENSION TRUSS LEFT	
NS	LA-272871	1	CU MOUNT, EXTENSION TRUSS RIGHT	
NS	EC-142101	1	CLMAP, HOSE R/C, 3/8	
<b>AXLE EXTENSION OPTION - FOR COMBINES WITH CNH 285MM AXLE EXTENSIONS</b>				
NS	LM-272791	2	CM ROD, AXEL EXENSION TRUSS	
NS	F-HN8F-20C	4	HN8 1-1/4-7 FLNG	AXLE EXT. TRUSS
NS	F-FW-20	4	FW 1-1/4	AXLE EXT. TRUSS

Model 3700S Hillco Leveling System  
For Serial Numbers 3700S-1601 thru 3700S-1699

**Carriage Fasteners**

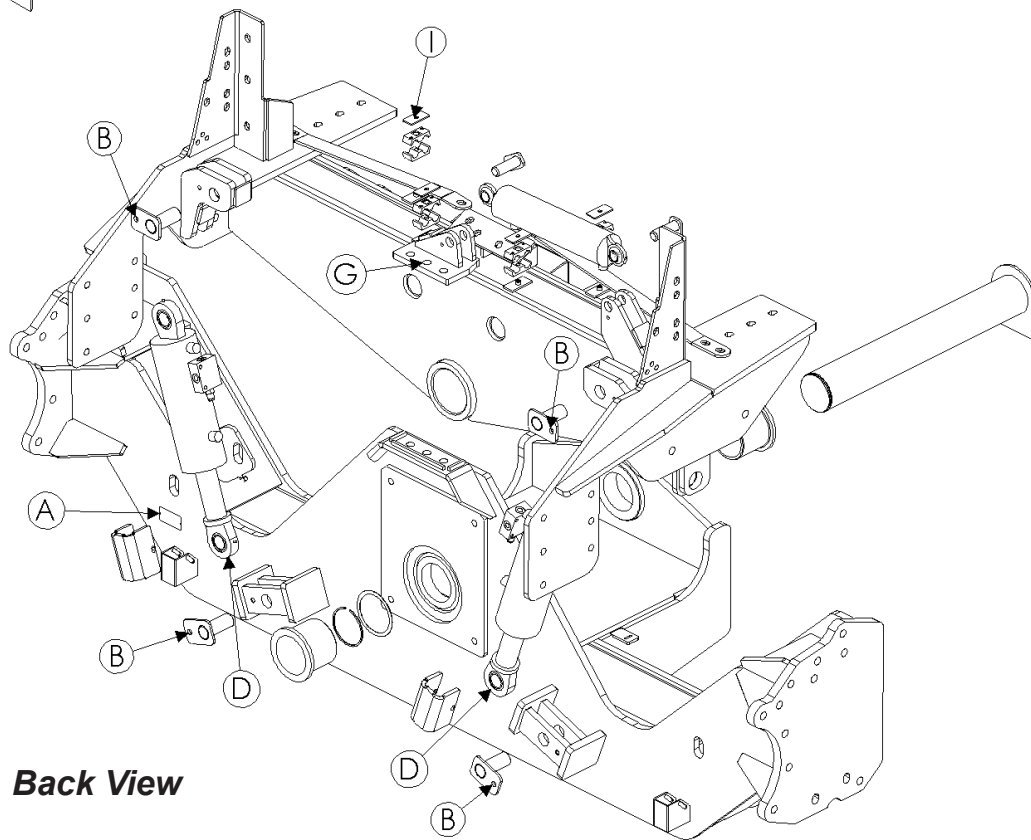
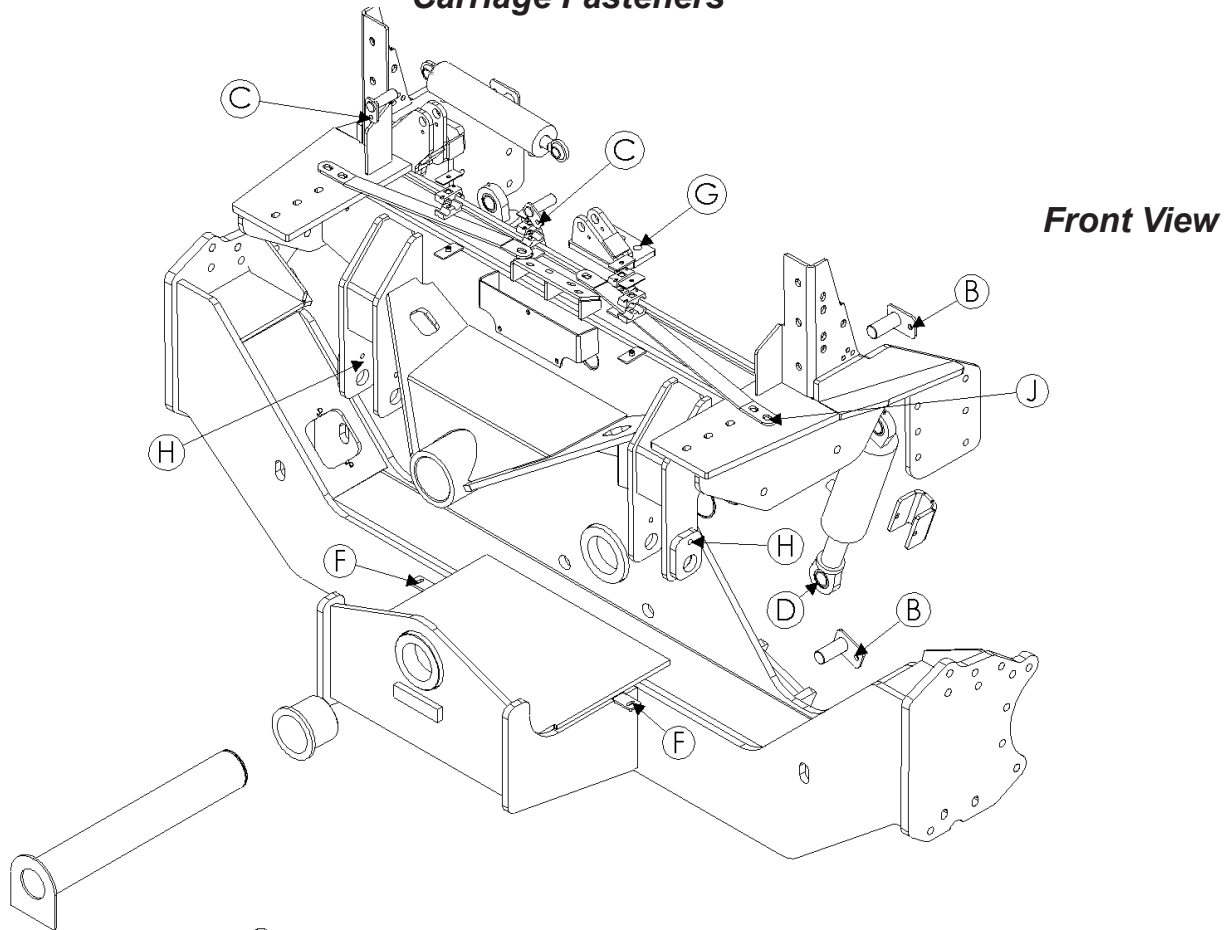

Model 3700S Hillco Leveling System  
For Serial Numbers 3700S-1601 thru 3700S-1699

<b>CARRIAGE FASTENERS</b>				
<b>REF.</b>	<b>PART NO.</b>	<b>QTY.</b>	<b>PART NAME</b>	<b>WHERE USED</b>
A	F-UDS-#7X06	2	#7 X 3/8 U-DRIVE SCREW	SERIAL NUMBER PLATE
B	F-HCF-12M025F	4	MM FLHC-8.8 M12 X 1.75 X 25 PLT	LEVELING CYL MNT PIN
C	F-HCF-10M020E	2	MM FLHC-10.9 M10 X 1.50 X 20 PLT	MASTER CYL MNT PIN
D	F-SSS-04F04	6	SET SCREW, 1/4-28 X 1/4	CYLINDERS
E	F-PSL-04X48	2	SNAP LOCK PIN 1/4 X 3	SAFETY STOPS ON CYLINDERS
F	F-EB-04C32	2	BOLT, ELEVATOR 1/4-20 X 2 PLT	LIMIT SWITCH STOPS
F	F-HNF-04C	4	HN 1/4-20 FLNG, SERR	LIMIT SWITCH STOPS
G	F-HCF-20M060E	3	FLHC-10.9 M20X2.2 X 60 PLT	MASTER CYL MNT
G	F-HNF-20ME	3	FLHN-10.9 M20 X 2.5 PLT	MASTER CYL MNT
H	F-HC-12M065F	2	HC-8.8 M12 X 1.75 X 65	HEADER LIFT CYLINDER PINS
I	HC-139461	4	BEHRINGER TWIN BOLT (FOR .750)	BERRINGER CLAMPS
J	F-HCF-16M040E	8	FLHC-10.9 M16 X 2.00 X 40	X-BRACES & OC TO C-CHANNEL
J	F-HNF-16ME	8	FLHN-10.9 M16 X 2.00	X-BRACES & OC TO C-CHANNEL
NS	F-HCF-16M050E	6	FLHC-10.9 M16 X 2.00 X 50	TRANSMISSION & FRONT OC BASE PLATE
NS	F-HCF-16M045E	8	FLHC-10.9 M16 X 2.00 X 45	OC BASE PLATE

Model 3700S Hillco Leveling System  
For Serial Numbers 3700S-1601 thru 3700S-1699

### Drop Axle

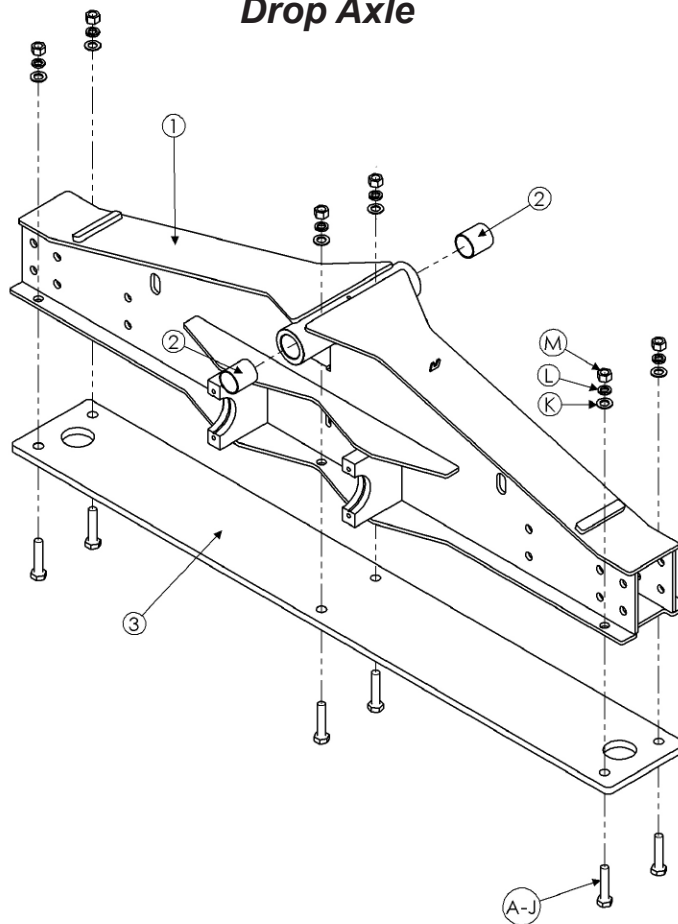

DROP AXLE COMPONENTS				
REF.	PART NO.	QTY.	PART NAME	NOTES
ASM	LA-272122	1	DA COMPLETE ASM, 3700S	
1	LA-270882	1	DA ASM	
2	MC-140791	2	REAR AXLE PIVOT SLEEVE	CNH Part # 84334438
3	LP-274462	0-10	DA WEIGHT, 159 LB.	AS NEEDED
DROP AXLE FASTENERS				
A	F-HC8-12C56	3	HC8 3/4-10 X 3-1/2	1 WEIGHT BOLT PACKAGE
B	F-HC8-12C56	3	HC8 3/4-10 X 3-1/2	2 WEIGHT BOLT PACKAGE
C	F-HC8-12C72	3	HC8 3/4-10 X 4-1/2	3 WEIGHT BOLT PACKAGE
D	F-HC8-12C88	3	HC8 3/4-10 X 5-1/2	4 WEIGHT BOLT PACKAGE
E	F-HC8-12C96	3	HC8 3/4-10 X 6	5 WEIGHT BOLT PACKAGE
F	F-HC8-12C112	3	HC8 3/4-10 X 7	6 WEIGHT BOLT PACKAGE
G	F-HC8-12C120	3	HC8 3/4-10 X 7-1/2	7 WEIGHT BOLT PACKAGE
H	F-HC8-12C136	3	HC8 3/4-10 X 8-1/2	8 WEIGHT BOLT PACKAGE
I	F-HC8-12C144	3	HC8 3/4-10 X 9	9 WEIGHT BOLT PACKAGE
J	F-HC8-12C160	3	HC8 3/4-10 X 10	10 WEIGHT BOLT PACKAGE
K	F-HN8-12C	3	HN8 3/4-10	ALL WEIGHT BOLT PACKAGES
L	F-LW-12A	3	LW 3/4 HD	ALL WEIGHT BOLT PACKAGES
M	F-FWH-12	3	FW 3/4 HD	ALL WEIGHT BOLT PACKAGES

Model 3700S Hillco Leveling System  
For Serial Numbers 3700S-1601 thru 3700S-1699

**Optional Ladder**

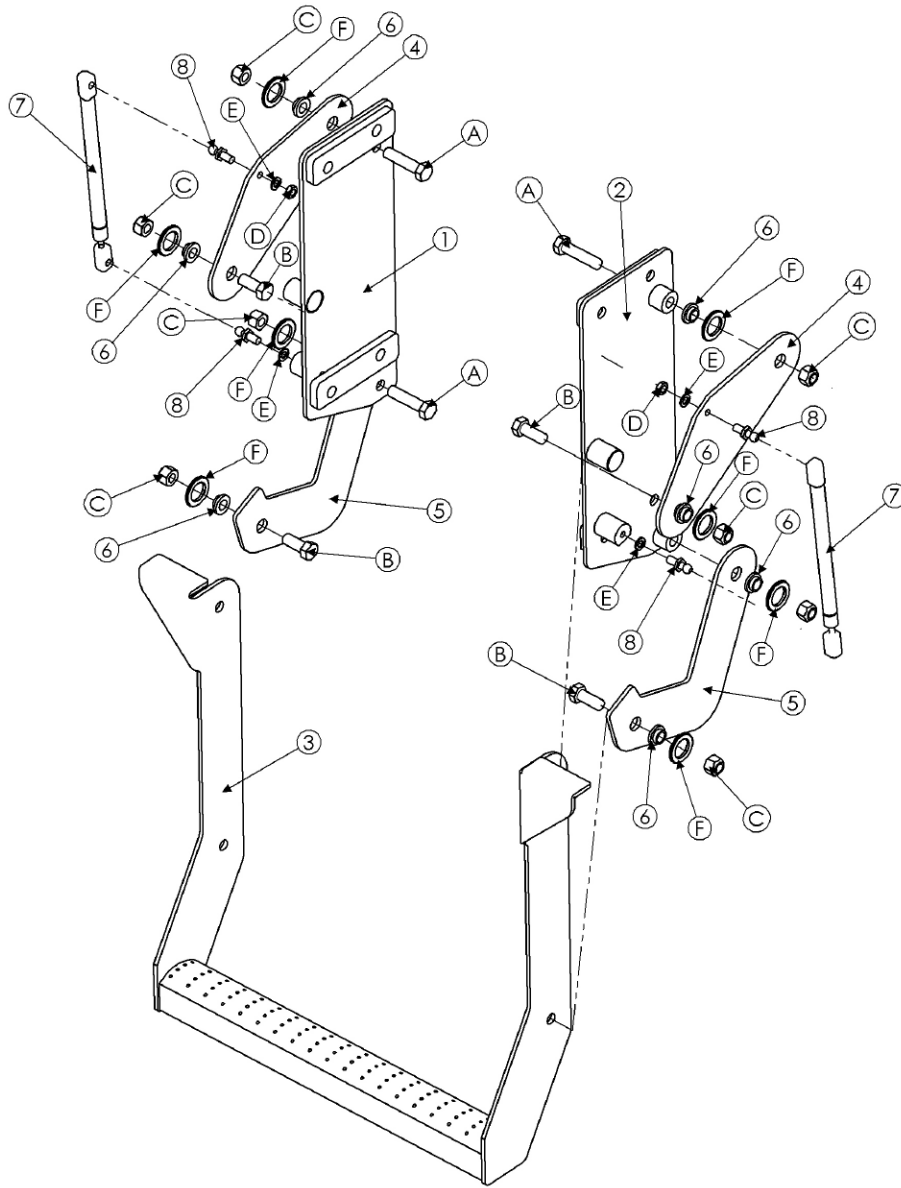

OPTIONAL LADDER COMPONENTS

REF.	PART NO.	QTY.	PART NAME	NOTES
ASM	LA-282021	1	LM ASM, 3700S RETRACTABLE LADDER	
1	LA-282001	1	LM ASM, LEFT LADDER MNT	
2	LA-281991	1	LM ASM, RIGHT LADDER MNT	
3	LA-282011	1	LM STEP ASM, PARALLEL	
4	LM-281951	2	LM PLATE, PARALLEL TOP	
5	LM-281961	2	LM LATE, PARALLEL BOTTOM	
6	LM-267981	8	LM BUSHING, LADDER PIVOT	
7	MC-150461	2	GAS CHARGED LIFT SUPPORT (40 LB)	
8	MC-134931	4	LIFT SUPPORT BRACKETS	
FASTENERS				
A	F-HC-12M050F	4	HC-8.8 M12 X 1.75 X 50 Plated [DIN 931]	LADDER SIDE PLATE PIVOTS
B	F-HC-12M030F	4	HC-8.8 M12 X 1.75 X 30 Plated [DIN 931]	LADDER STEP PIVOTS
C	F-HNS-12ME	8	HN-10.9 M12 X 1.75 Stover Plated [DIN 980 V]	LADDER PIVOTS AND STOP BOLTS
D	F-HNJ-05C	2	HN5 5/16-18 JAM NUT Plated	UPPER BALL STUDS
E	F-LW-05	4	LW 5/16	LADDER BALL STUDS
F	F-MB-10NR14	8	BUSHING, MACH 10 GA NR, 7/8 ID	LADDER PIVOTS



## Electrical

### MAIN ELECTRICAL CONTROL BOX

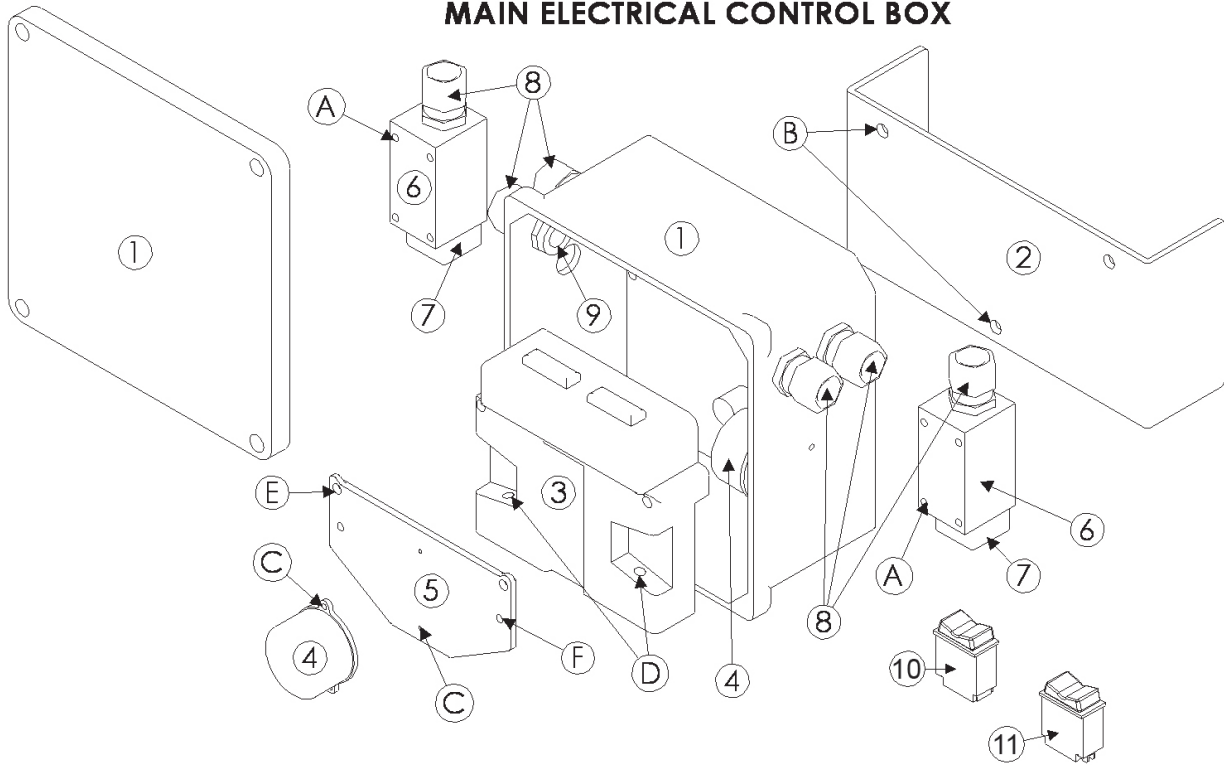

### Cab Control Monitor Assembly

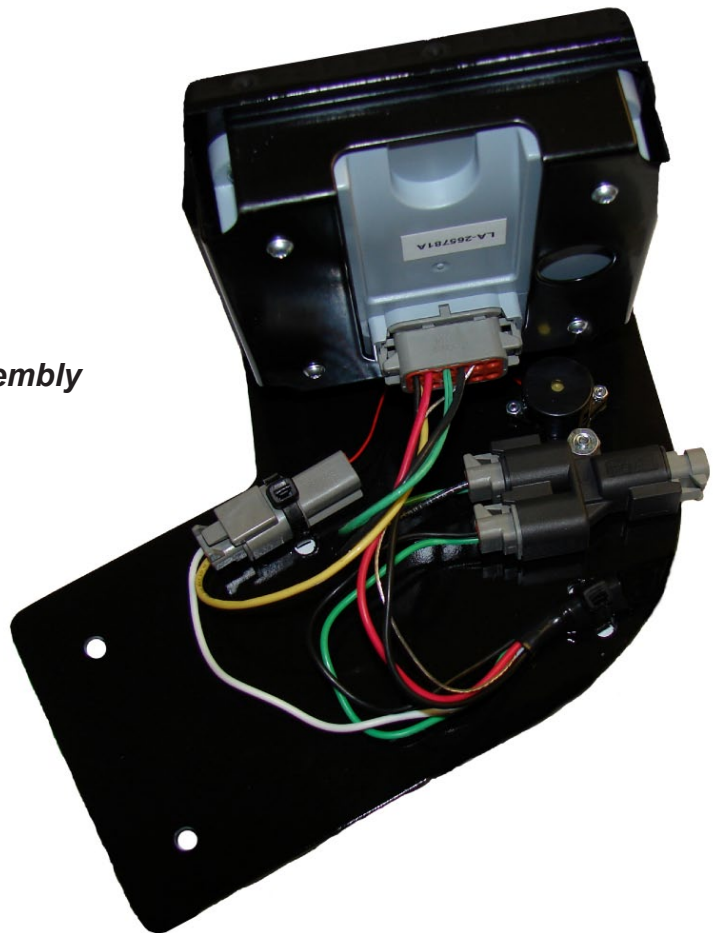

Model 3700S Hillco Leveling System  
For Serial Numbers 3700S-1601 thru 3700S-1699

<b>MAIN ELECTRICAL BOX COMPONENTS</b>				
<b>REF.</b>	<b>PART NO.</b>	<b>QTY.</b>	<b>PART NAME</b>	<b>NOTES</b>
ASM	LA-268271	1	EM ASM, CONTROLLER	
1	LM-260301	1	EM BOX, CONTROLLER MOUNT	
2	LP-266511	1	EM MOUNT, LEVELING BOX	WELDED TO CARRIAGE
3	EC-141831	1	CONTROLLER	
4	LA-255821	1	EM ASM, CLINOMETER	SEE NOTE BELOW DIAGRAM
5	LM-255331	1	EM SHT, CLINOMETER MOUNT	
6	EC-100557	2	BODY, LIMIT SWITCH	
7	EC-100692	2	HEAD, LIMIT SWITCH STRAIGHT PLUNGER	
8	EC-138781	6	STRAIN RELIEF, NYLON, BLK, 1/2 NPT	
9	EC-142121	4	STRAIN RELIEF NUT, 1/2" NYLON, BLK	
<b>REMOTE SWITCH CONTROLS</b>				
<b>REF.</b>	<b>PART NO.</b>	<b>QTY.</b>	<b>PART NAME</b>	<b>NOTES</b>
ASM	LA-281881	1	EM PACKAGE, REMOTE SWITCH	
10	EC-143401	1	SWITCH, LEFT/RIGHT LEVELING	
11	EC-150501	1	SWITCH, AUTO/MANUAL	
<b>FASTENERS</b>				
<b>REF.</b>	<b>PART NO.</b>	<b>QTY.</b>	<b>PART NAME</b>	<b>WHERE USED</b>
A	F-PHM-#10C28	4	PHMS 10-24 X 1-3/4	LIMIT SWITCH MNT
A	F-HNF-#10C	4	HN 10-24, FLNG SERR	LIMIT SWITCH MNT
B	F-HC5-04C12	3	HC5 1/4-20 X 3/4	PVC BOX TO BRACKET
B	F-LW-04	3	LW 1/4	PVC BOX TO BRACKET
C	F-PHM-#6C06	2	PHMS #6-32 X 3/8	CLINOMETER MOUNT
D	F-PHM-04C24	2	PHMS 1/4-20 X 1-1/2	CONTROLLER TO PVC BOX
D	F-HNF-04C	2	FLHN 1/4-20 SERR.	CONTROLLER TO PVC BOX
E	F-PHM-04C36	2	PHMS 1/4-20 X 2-1/4	GROUNDING PLATE MOUNTING
E	F-HNF-04C	2	FLHN 1/4-20 SERR.	GROUNDING PLATE MOUNTING
F	F-PHM-#10C12	2	PHMS 10-24 X 3/4	GROUNDING PLATE GROUND
F	F-HNF-#10C	2	HN5 10-24, FLNG SERR	GROUNDING PLATE GROUND
F	F-HN-#10C	2	HN 10-24	GROUNDING PLATE GROUND
<b>CAB CONTROL MONITOR DISPLAY</b>				
<b>REF.</b>	<b>PART NO.</b>	<b>QTY.</b>	<b>PART NAME</b>	<b>NOTES</b>
ASM	LA-273971	1	EM ASM, CAB CONTROL MONITOR	
..	LM-268281X	1	EM MOUNT, DISPLAY	
..	EC-146461	1	GRAPHICAL TERMINAL, S-D DP200	COMES WITH MOUNTING BRACKET, GASKET, & SCREWS
..	LA-268301	1	EM CABLE ASM, CAB TO BOX	SEE PAGE 5-3
..	EC-146531	1	Y-CONNECTOR, BLACK	
..	EC-146541	1	PLUG, GRAY, W/120 OHM RESISTOR	
..	EC-138781	2	STRAIN RELIEF, NYLON, BLK, 1/2 NPT	
..	EC-142121	2	STRAIN RELIEF NUT, 1/2" NYLON, BLK	
<b>FASTENERS</b>				
..	F-PHM-#10C08	1	PHMS 10-24 X 1/2	Y-CONNECTOR MOUNTING
..	F-HN-#10C	1	HN5 10-24	Y-CONNECTOR MOUNTING

**Electrical Connectors and Cables**



#1 LA-268261  
EM CABLE ASM, LIMIT SWITCH



#2 LA-268311  
EM CABLE ASM, BOX TO VALVE



#3 LA-261191  
EM ASM, CLINOMETER



#4 LA-268351  
EM CABLE ASM, MANIFOLD



#5 LA-268301  
EM CABLE ASM, CAB TO BOX



#6 LA-268291  
EM CABLE ASM, POWER & GROUND



#7 LA-289201  
EM CABLE ASM, REMOTE SWITCH

Model 3700S Hillco Leveling System  
For Serial Numbers 3700S-1601 thru 3700S-1699

<b>CABLE ASSEMBLIES</b>				
<b>REF.</b>	<b>PART NO.</b>	<b>QTY.</b>	<b>PART NAME</b>	<b>NOTES</b>
1	LA-268261	2	EM CABLE ASM, LIMIT SWITCH	26" 2W
2	LA-268311	1	EM CABLE ASM, BOX TO VALVE	106" 6W
3	LA-261191	1	EM ASM, CLINOMETER	
4	LA-268351	1	EM CABLE ASM, MANIFOLD	
..	LA-276661	1	EM CABLE ASM, LEVELING MANIFOLD	INCLUDED IN LA-268351, 12" 4w
5	LA-268301	1	EM CABLE ASM, CAB TO BOX	176" 6W
6	LA-268291	1	EM CABLE ASM, POWER & GROUND	128" 2W
7	LA-289201	1	EM CABLE ASM, REMOTE SWITCH	
<b>ELECTRICAL CONNECTORS</b>				
<b>REF.</b>	<b>PART NO.</b>	<b>QTY.</b>	<b>PART NAME</b>	<b>NOTES</b>
NS	EC-141741	4	DTM SERIES, 12-SOCKET WEDGE	
NS	EC-141751	3	DTM SERIES, 12-SOCKET PLUG W/ A-KEY	
NS	EC-141761	1	DTM SERIES, 12-SOCKET PLUG W/ B-KEY	
NS	EC-143261	1	DTM SERIES, 12- PIN RECEPTACLE	
NS	EC-143271	1	DTM SERIES, 12-SOCKET WEDGE	
NS	EC-145671	18	DTM SERIES, PLUG, SEALING	
NS	EC-146521	2	DTM SERIES, 2-SOCKET WEDGE W/B KEY, BLACK	
NS	EC-146581	31	DTM SERIES, SOCKET CONTACT, STAMPED	
NS	EC-141781	4	DTM SERIES, PIN CONTACT, STAMPED	
NS	EC-139641	2	CONNECTOR, PARALLEL, 16-14 GA	
NS	ET-ST-20#10	6	TERMINAL, TERMINAL, #10, 20 GA., NON-INSULATED	
NS	ET-ST-2004	1	TERMINAL, RING, NON-INS, 1/4, 20 GA	
NS	ET-ST-1406	1	TERMINAL, RING, 3/8, 14 GA, NON-INSULATED	
NS	EC-146511	2	PLUG, GRAY, 2-SOCKET	
NS	EC-146881	1	MINI FUSE HOLDER, ATM	
NS	EC-146891	1	MINI BLADE FUSE, ATM, 5AMP	

Model 3700S Hillco Leveling System  
For Serial Numbers 3700S-1601 thru 3700S-1699

**Hydraulics**

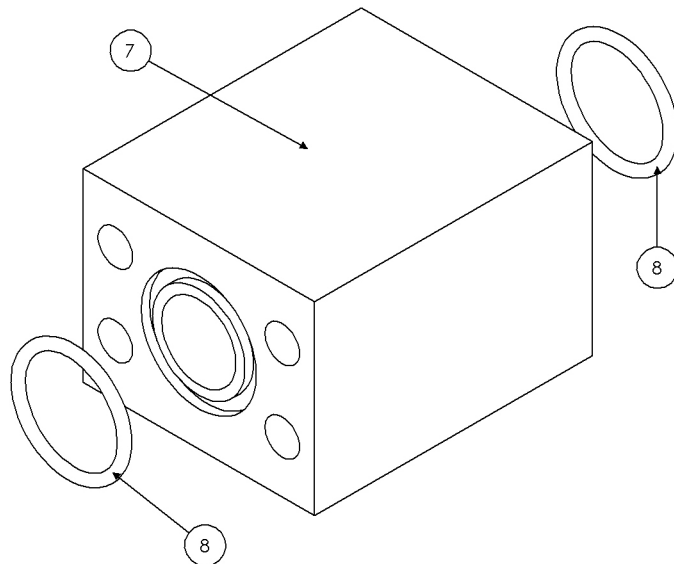
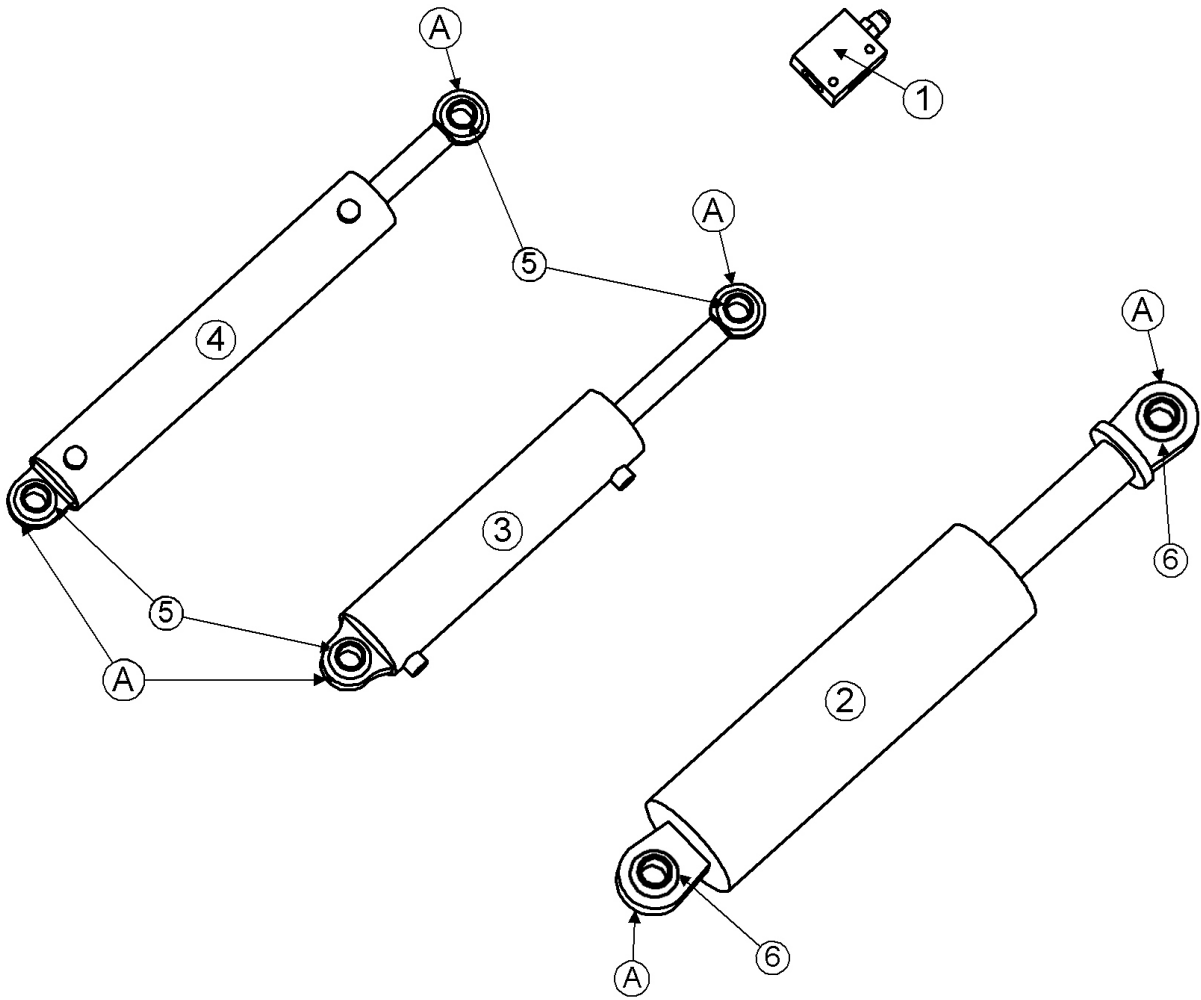

Model 3700S Hillco Leveling System  
For Serial Numbers 3700S-1601 thru 3700S-1699

<b>COUNTERBALANCE VALVE AND CYLINDERS</b>				
<b>REF.</b>	<b>PART NO.</b>	<b>QTY.</b>	<b>PART NAME</b>	<b>NOTES</b>
1	HC-138901	2	VALVE, 3-PORT COUNTERBALANCE	MAIN LEVELING CYLINDERS BASE END
..	HC-139171	2	BODY, COUNTERBALANCE VALVE	
..	HC-139161	2	CARTRIDGE, COUNTERBALANCE VALVE	
NS	HC-140361	2	SEAL KIT, COUNTERBALANCE VALVE	
2	HC-140313	2	CYLINDER, MAIN LEVELING	
3	HC-140342	1	CYLINDER, MASTER LEVELING	
4	HC-138582	1	CYLINDER, SLAVE	
5	MC-150871	4	1" BEARING, SEALED SPHERICAL	
6	MC-150881	4	1 3/8" BEARING, SEALED SPHERICAL	
HYDRO HOSE EXTENSION FOR COMBINES WITH REAR WHEEL ASSIST				
ASM	LA-272701	1	HYDRO HOSE EXTENSION FOR COMBINES WITH RWA	
7	HC-140011	1	HM EXTENSION, FORWARD PROPULSION	FLT 1018 CD 2-1/2 X 3-1/2
NS	F-HC8-07C88	4	HC8 7/16-14 X 5-1/2	
NS	F-LWH-07	4	LW 7/16 HD	
8	HC-147551	2	O-RING, CODE 62, 1"	
HYDRO HOSE EXTENSIONS FOR COMBINES WITHOUT REAR WHEEL ASSIST				
ASM	LA-272831	1	HYDRO HOSE EXTENSION FOR COMBINES WITHOUT RWA	
7	HC-140011	2	HM EXTENSION, FORWARD PROPULSION	FLT 1018 CD 2-1/2 X 3-1/2
NS	F-HC8-07C88	8	HC8 7/16-14 X 5-1/2	
NS	F-LWH-07	8	LW 7/16 HD	
8	HC-147551	4	O-RING, CODE 62, 1"	
<b>HYDRAULIC FASTENERS</b>				
<b>REF.</b>	<b>PART NO.</b>	<b>QTY.</b>	<b>PART NAME</b>	<b>WHERE USED</b>
A	F-SSS-04F04	6	SET SCREW, 1/4-28 X 1/4	CYLINDERS

Model 3700S Hillco Leveling System  
For Serial Numbers 3700S-1601 thru 3700S-1699

**Hydraulic Manifold**

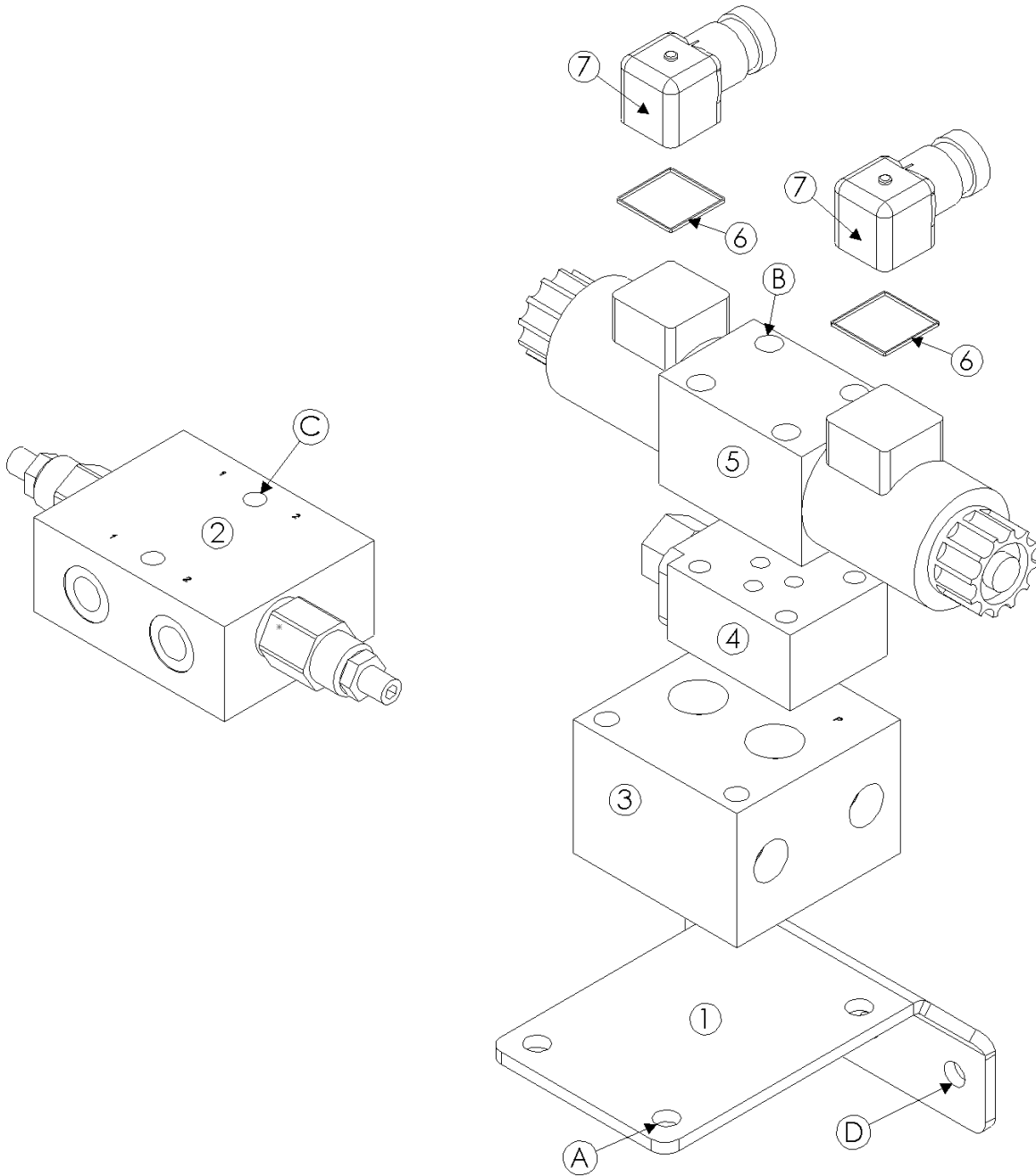

Model 3700S Hillco Leveling System  
For Serial Numbers 3700S-1601 thru 3700S-1699

<b>MANIFOLD COMPONENTS</b>				
<b>REF.</b>	<b>PART NO.</b>	<b>QTY.</b>	<b>PART NAME</b>	<b>NOTES</b>
ASM	LA-276671	1	LEVELING MANIFOLD ASM	
1	LP-268121	1	HM PLATE, MANIFOLD MOUNT	
2	HC-138691	1	MANIFOLD, RELIEF VALVE	HEADER TRIM CIRCUIT
..	HC-141351	2	CARTRIDGE, RELIEF VALVE	
NS	HC-141361	2	SEAL KIT, RELIEF VALVE	
3	HC-138861	1	MANIFOLD, SINGLE STATION	
4	HC-101264	1	LOAD SENSE SHUTTLE ASM	
..	HC-101021	1	CARTRIDGE, LOAD SENSE VALVE	
..	HC-101022	1	BODY, LOAD SENSE VALVE	
NS	HC-102082	1	SEAL KIT, LOAD SENSE SHUTTLE ASM	
5	HC-140411	1	DIRECTIONAL CONTROL VALVE	
NS	LM-250111	1	ORIFICE, .128	DIRECTIONAL CONTROL VALVE
NS	HC-142731	1	SEAL KIT, DIRECTIONAL CONTROL VALVE	
6	HC-142971	2	GASKET, DIN CONNECTOR	COILS ON DIR CONTROL VALVES
7	HC-140291	2	PLUG, DIN, LIGHTED	COILS ON DIRECTIONAL CONTROL VALVES

<b>MANIFOLD FASTENERS</b>				
<b>REF.</b>	<b>PART NO.</b>	<b>QTY.</b>	<b>PART NAME</b>	<b>WHERE USED</b>
A	F-HCF-08M020E	4	FLHC-10.9 M8 X 1.25 X 20 PLT	SECURES MANIFOLD TO MOUNTING PLATE
A	F-HNF-08ME	4	FLHN-10.9 M8 X 1.25 PLT	SECURES MANIFOLD TO MOUNTING PLATE
B	F-SHC-#10C52	4	SHCS 10-24 X 3-1/4	MANIFOLD ASM
B	F-LW-#10	4	LW #10	MANIFOLD ASM
C	F-HCF-08M050E	2	FLHC-10.9 M8 X 1.25 X 50	RELIEF VALVE TO COMBINE
C	F-HNF-08ME	2	FLHN-10.9 M8 X 1.25 PLT	RELIEF VALVE TO COMBINE
D	F-HCF-08M020E	2	FLHC-10.9 M8 X 1.25 X 20 PLT	MANIFOLD ASM TO COMBINE
D	F-HNF-08ME	2	FLHN-10.9 M8 X 1.25 PLT	MANIFOLD ASM TO COMBINE



Model 3700S Hillco Leveling System  
For Serial Numbers 3700S-1601 thru 3700S-1699

### Hydraulic Hoses

LEVELING AND TRIM				
REF.	PART NO.	QTY.	PART NAME	WHERE USED
NS	LA-272641	1	3/8" 100R2 HOSE 45" #6 FORS X #6 FORS 90°	COUNTERBALANCE VALVE PORT #2 RIGHT TO COUNTERBALANCE VALVE PORT #3 LEFT
NS	LA-272651	1	3/8" 100R2 HOSE 49" #6 FORS X #6 FORS 90°	COUNTERBALANCE VALVE PORT #3 RIGHT TO COUNTERBALANCE VALVE PORT #2 LEFT
NS	LA-272661	2	3/8" 100R2 HOSE 5-5/8" #6 FORS X #6 FORS 90°	MAIN ROD TO COUNTERBALANCE VALVE PORT #3 (LEFT & RIGHT)
NS	LA-146991	1	3/8" 100R2 HOSE 86" #6 FORS 90° X #6 FORS STR.	LEVELING PORT "B" TO COUNTERBALANCE VALVE PORT #2 LEFT
NS	LA-146991	1	3/8" 100R2 HOSE 86" #6 FORS 90° X #6 FORS STR.	LEVELING PORT "A" TO COUNTERBALANCE VALVE PORT #3 LEFT
NS	LA-147271	1	1/4" 100R2 HOSE 98" #6 FORS X #6 FORS 90°	MASTER CYLINDER BASE TO SLAVE CYLINDER BASE
NS	LA-139801	1	1/4" 100R2 HOSE 102" #6 FORS X #6 FORS	MASTER CYL ROD TO SLAVE CYL ROD
NS	LA-146851	1	1/4" 100R2 HOSE 30" #6 FORS X #4 FORS	LOAD SENSE LINE
NS	LA-146861	1	5/8" 100R2 HOSE 37" #10 FORS X #10 FORS 90°	LEVELING VALVE PRESSURE HOSE
NS	LA-146871	1	5/8" 100R2 HOSE 36" #10 FORS X #10 FORS	LEVELING VALVE RETURN HOSE
NS	HC-143581	1	ABRASION SLEEVE, NYLON -- 1.22 ID X 24"	HOSES TO SLAVE CYLINDER
NS	LA-147161	2	1/4" 100R2 HOSE 20" #6 FORS X #6 FORS	"FTR" & "FTP" PORTS ON FIELD TRACKER VALVE TO #1 & #2 PORTS ON CROSS PORT RELIEF
NS	LA-147021	1	1/4" 100R2 HOSE 93" #6 FORS X #6 FORS	CROSS PORT RELIEF #2 TO MASTER ROD
NS	LA-140591	1	1/4" 100R2 HOSE 104" #6 FORS X #6 FORS	CROSS PORT RELIEF #1 TO MASTER BASE
<b>HEADER LIFT CYLINDER HOSES</b>				
NS	LA-147031	2	1/2" 100R2 HOSE 46" #8 FORS 45° X #8 FORS	HEADER LIFT HOSES
NS	HC-143581	2	ABRASION SLEEVE, NYLON -- 1.22 ID X 24 IN	HEADER LIFT HOSES
<b>DROP AXLE</b>				
NS	LA-133331	1	3/16 R1 12" GREASE HOSE 1/8 MPT X 1/8 MPT	REAR AXLE ZERK
<b>GREASE</b>				
NS	LA-133331	3	3/16" R1 12" GREASE HOSE 1/8 MPT X 1/8 MPT	L & R MAIN LEVELING CYLINDER BASE TO LEFT AND RIGHT BULKHEADS
NS	LA-140101	2	3/16" R1 48" GREASE HOSE 1/8 MPT X 1/8 MPT	MASTER ROD TO RH BULKHEAD & MAIN PIVOT PIN TO LH BULKHEAD
<b>BRAKE HOSES</b>				
NS	LA-146951	1	3/8" 100R2 HOSE 106" #6 FORS 90° X #6 FORS	RIGHT BRAKE HOSE TO HOSE W/ 90° END
NS	LA-146961	1	3/8" 100R2 HOSE 106" #6 FORS X #6 FORS	LEFT BRAKE HOSE TO HOSE W/ STR. END
NS	LA-142141	1	3/8" 100R2 HOSE 36" #6 FORS 90° X #6 FORS 90°	REPLACES STEEL BRAKE LINE LOOP
NS	HC-143581	2	ABRASION SLEEVE, NYLON -- 1.22 ID X 24"	BRAKE HOSES
<b>HYDRO HOSES</b>				
NS	HC-133541	3	ABRASION SLEEVE, NYLON -- 2.19 ID X 32"	HYDRO HOSES
<b>STEERING HOSES</b>				
NS	LA-146971	1	3/8" 100R2 HOSE 39" #8 FORS 90° X #8 FORS	BOTTOM STEERING LINE
NS	LA-146981	1	3/8" 100R2 HOSE 36" #8 FORS 90° X #8 MORS	TOP STEERING LINE
<b>FEEDERHOUSE ENGAGE HOSES</b>				
NS	LA-147001	1	3/8" 100R2 HOSE 80" #6 FORS X #8 FORS	C2 PORT ON BRAKE VALVE TO ENGAGE CYLINDER ROD
NS	LA-147011	1	3/8" 100R2 HOSE 80" #6 FORS 90° X #6 FORS	C1 PORT ON BRAKE VALVE TO ENGAGE CYLINDER BASE
NS	HC-142151	2	ABRASION SLEEVE, NYLON -- 1.66 ID X 12"	FEEDER ENGAGE HOSES
<b>FOR COMBINES WITH REAR WHEEL ASSIST</b>				
NS	HC-140011	1	HM EXTENSION, FORWARD PROPULSION	
NS	F-HC8-07C88	4	HC8 7/16-14 X 5-1/2	HYDRO FORWARD PROPULSION EXTENSION
NS	F-LWH-07	4	LW 7/16 HD	HYDRO FORWARD PROPULSION EXTENSION
NS	HC-147551	2	O-RING, CODE 62, 1"	HYDRO FORWARD PROPULSION EXTENSION
<b>FOR COMBINES WITHOUT REAR WHEEL ASSIST</b>				
NS	HC-140011	2	HM EXTENSION, FORWARD PROPULSION	
NS	F-HC8-07C88	8	HC8 7/16-14 X 5-1/2	HYDRO FORWARD PROPULSION EXTENSION
NS	F-LWH-07	8	LW 7/16 HD	HYDRO FORWARD PROPULSION EXTENSION
NS	HC-147551	4	O-RING, CODE 62, 1"	HYDRO FORWARD PROPULSION EXTENSION

Model 3700S Hillco Leveling System  
For Serial Numbers 3700S-1601 thru 3700S-1699

### Hydraulic Adapters

REF.	PART NO.	QTY.	PART NAME	WHERE USED
NS	HA-L-8FF8MF	2	#8 FORS X #8 MORS 90°	STEERING CYLINDER PORTS
NS	HA-L-6FF6MF	1	#6 FORS X #6 MORS 90°	LEFT BRAKE PORT ON TRANSMISSION
NS	HA-L-6FF6MF	1	#6 FORS X #6 MORS 90°	FEEDER ENGAGE PORT ON BRAKE VALVE
NS	HA-F-6FF6MF	1	#6 FORS X #6 MORS 45°	BRAKE VALVE PRESSURE PORT
NS	HA-F-16FF16MF	1	#16 FORS X #16 MORS 45°	CASE DRAIN ON HYDRO MOTOR
NS	HA-L-16FF16MF	1	#16 FORS X #16 MORS 90°	CASE DRAIN ON HYDRO PUMP
<b>LEVELING MANIFOLD</b>				
NS	HA-L-6MF4MO	4	#4 MORB X #6 MORS 90°	#1 & #2 PORTS IN RELIEF VALVE
NS	HA-E-10MO	2	#10 MORB SOCKET HEAD PLUG (ZERO-LEAK)	"P" & "T" PORTS
NS	HA-S-10MF10MO	2	#10 MORS X #10 MORB STR.	"P" & "T" PORTS
NS	HA-L-6MF8MO	2	#6 MORS X #8 MORB 90°	"A" & "B" PORTS
NS	HA-L-4MF4MO	1	#4 MORS X #4 MORB 90°	LOAD SENSE SHUTTLE
NS	HA-L-10FF10MF	2	#10 FORS X #10 MORS 90°	"P" & "T" PORTS
NS	HA-M-6FF6MF	1	#6 ORS SWIVEL NUT RUN TEE	"LS" PORT ON COMBINE MANIFOLD
NS	HA-M-10FF10MF	1	#10 ORS SWIVEL NUT RUN TEE	"PX" PORT ON COMBINE MANIFOLD
NS	HA-L-10MF10MO	1	#10 MORS X # 10 MORB 90°	"RX" PORT ON COMBINE MANIFOLD
NS	HA-S-6MF6MO	2	#6 MORS X # 6 MORB STR	"FTR" & "FTP" PORTS ON COMBINE MANIFOLD
<b>MAIN CYLINDER AND COUNTERBALANCE VALVE</b>				
NS	HA-S-6FO8MO	2	#8 MORB X #6 FORB STR	LEFT & RIGHT MAIN CYLINDER BASE
NS	HA-L-6MO6MO	2	#6 MORB X #6 MORB 90°	LEFT AND RIGHT COUNTERBALANCE VALVE PORT #1 TO MAIN CYLINDER BASE
NS	HA-L-6MF6MO	2	#6 MORS X #6 MORB 90°	LEFT & RIGHT MAIN CYLINDER ROD
NS	HA-Q-6MF6MO	2	#6 MORS STRAIGHT THREAD BRANCH TEE	LEFT & RIGHT COUNTERBALANCE VALVE PORT #3 AND COUNTERBALANCE #2 LEFT
NS	HA-M-6FF6MF	1	#6 MORS X #6 FORS SWIVEL NUT RUN TEE	LEFT COUNTERBALANCE VALVE PORT #2
NS	HA-M-6FF6MF	1	#6 MORS X #6 FORS SWIVEL NUT RUN TEE	LEFT COUNTERBALANCE VALVE PORT #3
NS	HA-L-6MF6MO	1	#6 MORS X # 6 MORB 90°	RIGHT COUNTERBALANCE VALVE PORT #2
<b>MASTER AND SLAVE CYLINDERS</b>				
NS	HA-Q-6MF6MO	2	#6 MORS STRAIGHT THREAD BRANCH TEE	MASTER BASE & ROD PORTS
NS	HA-F-6MF6MO	2	#6 MORS X #6 MORB 45°	SLAVE BASE & ROD PORTS
<b>GREASE</b>				
NS	HC-141231	1	ZERK, GREASE 1/8 MPT 45°	
NS	HA-L-2FP2MP	1	1/8 MPT 90 STREET EL	MAIN PIVOT PIN
NS	HC-135771	4	1/4-28 MALE X 1/8 FPT 90°	MASTER & LEVLEING CYLINDER BASE
NS	HA-S-2MN2FP	5	1/8 NPSM X 1/8 FPT BULKHEAD CONNECTOR	GREASE BULKHEAD CONNECTORS
NS	HA-NJ-2FN	5	1/8 NPSM BULKHEAD LOCKNUT	GREASE BULKHEAD CONNECTORS
NS	HC-138011	5	ZERK, GREASE 1/4-28 STRAIGHT	ALL GREASE HOSES
<b>GREASE DROP AXLE</b>				
NS	HA-L-2FP2MP	1	1/8 MPT 90 STREET EL	DROP AXLE MAIN PIVOT PIN
NS	HA-S-2MN2FP	1	1/8 NPSM X 1/8 FPT BULKHEAD CONNECTOR	GREASE BULKHEAD CONNECTORS
NS	HA-NJ-2FN	1	1/8 NPSM BULKHEAD LOCKNUT	GREASE BULKHEAD CONNECTORS
NS	HC-138011	1	ZERK, GREASE 1/4-28 STRAIGHT	ALL GREASE HOSES

**Miscellaneous**



1 - LL-33741



2 - LL-147661

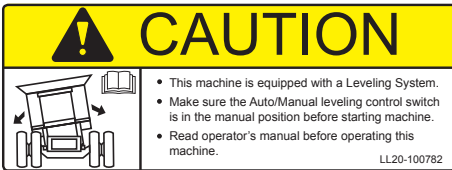

3 - LL20-100782



5 - LL20-100784



4 - LL20-100783



6 - LL20-100787

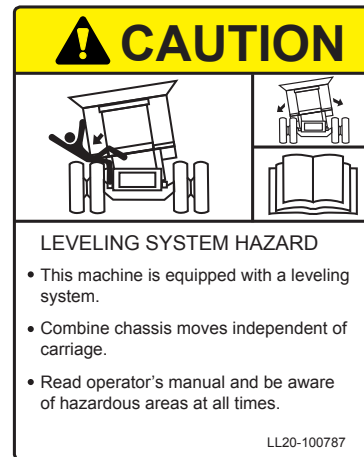

7 - LL20-100787



8 - LL20-100788



9 - LL-150511



10 - LL150521

Model 3700S Hillco Leveling System  
For Serial Numbers 3700S-1601 thru 3700S-1699

<b>DOCUMENTS AND LABELS</b>				
<b>REF.</b>	<b>PART NO.</b>	<b>QTY.</b>	<b>PART NAME</b>	<b>NOTES</b>
NS	D-050611SLR01	1	WARRANTY REG CARD	SENT WITH OPERATOR'S MANUAL
NS	D-090303DJC01	1	3700S OPERATOR'S MANUAL	
NS	D-090310DJC01	1	DEALER PDI CHECKLIST	
NS	D-090329DJC01	1	FI PDI CHECKLIST	
NS	D-100402ADL01	1	3700S PARTS BOOK	
NS	LA-270031	1	TAG, SERIAL NUMBER 3700S	LEFT REAR OF UNDERCARRIAGE
NS	LL-133741	1	LABEL, GREASE 50 HRS	BY BASE END OF SLAVE CYLINDER
NS	LL-133741	2	LABEL, GREASE 50 HRS	
1	LL-133741	2	LABEL, GREASE 50 HRS	MAIN LEV CYL BOTTOM LEFT & RIGHT
1	LL-133741	2	LABEL, GREASE 50 HRS	BULKHEAD MOUNT LEFT & RIGHT
NS	LL-143621	2	DANGER, AVOID CRUSHING INJURY	REAR OF UNDERCARRIAGE NEAR THE SAFETY STOP MOUNTS
2	LL-147661	2	DECAL, CASE SIDEHILL LEVELING SYSTEM	SIDE PANELS ON COMBINE
3	LL20-100782	1	CAUTION LEVELING SYSTEM CAB	WINDOW IN CAB
4	LL20-100783	2	DANGER, CRUSHING HAZARD	FRONT OF UNDERCARRIAGE LEFT & RIGHT
4	LL20-100783	2	DANGER CRUSHING HAZARD	SIDE OF COMBINE ABOVE REAR TIRES
5	LL20-100784	2	DANGER PINCH POINT	UPPER TRANS FACE PLATE LEFT & RIGHT
6	LL20-100786	1	WARNING ELECTRONIC CRUSHING HAZARD	FRONT OF CONTROL BOX
7	LL20-100787	1	CAUTION LEVELING SYSTEM HAZARD	CLEAN GRAIN ELEVATOR-RIGHT; SCREEN- LEFT
8	LL20-100788	1	HYDRAULIC HAZARD DECAL	ABOVE HYDRAULIC MANIFOLD
8	LL20-100788	2	DANGER HYDRAULIC HAZARD	1- EA MAIN CYLINDERS
NS	LL-239412	1	LABEL, STEERING WHEEL	TIED TO STEERING WHEEL DURING INSTALLATION
NS	LL-274401	1	LIMIT SWITCH WARNING LABEL	INSTALLED ON 1 LIMIT SWITCH
9	LL-150511	1	LABEL, LEFT/RIGHT LEVELING	
10	LL-150521	1	LABEL, AUTO/MANUAL	

<b>MISCELLANEOUS COMPONENTS</b>				
<b>REF.</b>	<b>PART NO.</b>	<b>QTY.</b>	<b>PART NAME</b>	<b>NOTES</b>
NS	HC-139431	4	BEHRINGER TWIN CLAMP .750 DIAMETER	BRAKE & HEADER LIFT HOSES ON TOP OF OVERCARRIAGE
NS	HC-139431	2	BEHRINGER TWIN CLAMP .750 DIAMETER	BRAKE & STEERING HOSES AT AUGER BED
NS	HC-139451	2	BEHRINGER TWIN COVER PLATE (FOR .750)	BRAKE HOSES ON TOP OF OVERCARRIAGE
NS	HC-139451	1	BEHRINGER TWIN COVER PLATE (FOR .750)	BRAKE & STEERING HOSES AT AUGER BED
NS	HC-139461	1	BEHRINGER TWIN BOLT (FOR .750)	HEADER LIFT HOSES ON TOP OF OVERCARRIAGE
NS	HC-139471	2	BEHRINGER STACK BOLT (FOR .750)	BRAKE HOSES ON TOP OF OVERCARRIAGE
NS	F-HC-08M100F	1	HC-8.8 M8 X 1.25 X 100	HOSE CLAMPS FOR BRAKE & STEERING HOSES
NS	F-HNF-08ME	1	FLHN-10.9 M8 X 1.25 PLT	HOSE CLAMPS FOR BRAKE & STEERING HOSES
NS	MC-135631	2	CLAMP, HOSE 1-1/2 R/C W/ 3/8" HOLE	CLAMPS FOR TRIM HOSES
NS	F-HNF-08ME	2	FLHN-10.9 M8 X 1.25	CLAMPS FOR TRIM HOSES
NS	F-HCF-08M020E	2	FLHC-10.9 M8 X 1.25 X 20	CLAMPS FOR TRIM HOSES

Model 3700S Hillco Leveling System  
For Serial Numbers 3700S-1601 thru 3700S-1699

Hillco Technologies, Inc.  
107 1st Avenue  
Nezperce, Idaho 83543

Phone	800-937-2461
	208-937-2461
Fax	208-937-2280

[www.hillcotechnologies.com](http://www.hillcotechnologies.com)  
email: [support@hillcotechnologies.com](mailto:support@hillcotechnologies.com)