

Model 2810
Hillside Leveling System
Parts Manual
SN 2810-1301 thru 2810-1399
D-070801ADL01A





2810 Leveling System *for AFX 8010 Combines*

TABLE OF CONTENTS

1 GENERAL INFORMATION	1-3
Serial Number Location	1-3
Text Format and Illustrations	1-3
Abbreviations.....	1-3
Right and Left Identification	1-3
Parts Orders	1-3
2 TRANSITION	2-1
Radial Pin Slip Clutch	2-3
Transition Fasteners.....	2-5
Wheel, Wheel Spacer & Wheel Washer	2-7
3 CARRIAGE	3-1
Carriage Fasteners.....	3-3
4 DROP AXLE	4-1
5 LADDER	5-1
6 ELECTRICAL	6-1
Electrical Connectors and Cables	6-3
7 HYDRAULICS	7-1
Hydraulic Manifold.....	7-3
Hydraulic Hoses	7-5
Hydraulic Adapters	7-6
8 MISCELLANEOUS	8-1
9 PART NUMBER INDEX	9-1
Part Number Index (Continued).....	9-2

Model 2810 Hillco Leveling System
For Serial Numbers 2810-1301 thru 2810-1399

Hillco Technologies, Inc.
107 1st Avenue
Nezperce Id. 83543

Fax	208.937.2280
Phone	208.937.2461
Toll Free	800.937.2461

www.hillcotechnologies.com

1 GENERAL INFORMATION

SERIAL NUMBER LOCATION

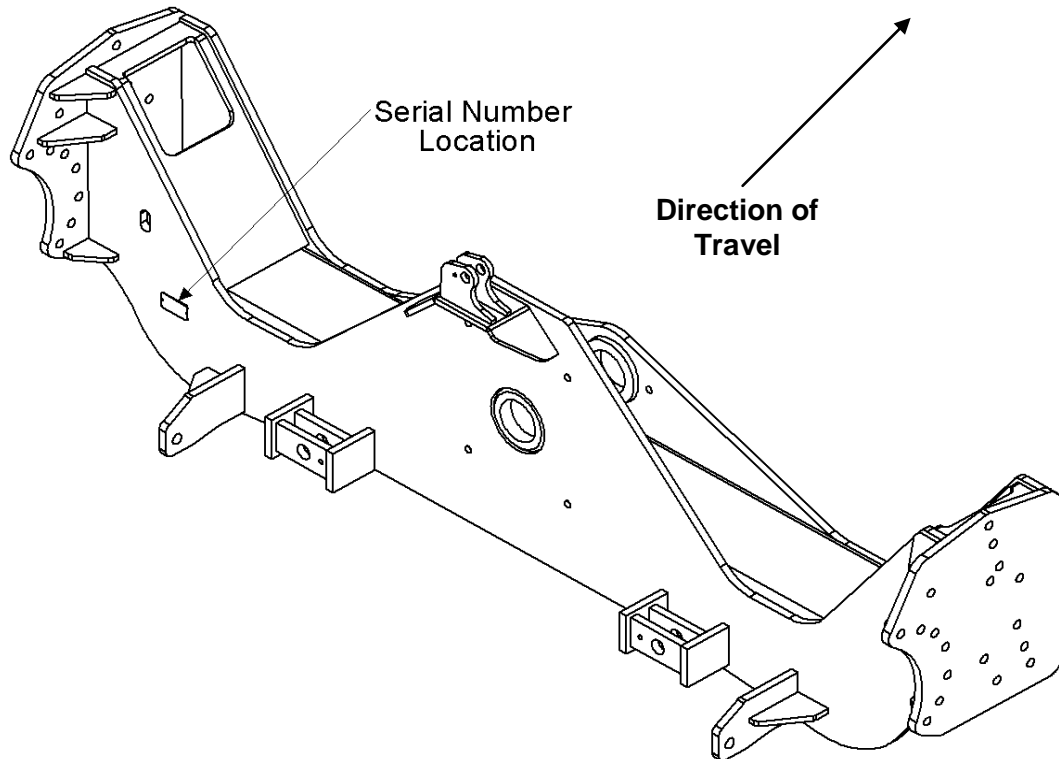

TEXT FORMAT AND ILLUSTRATIONS

The arrangement of this parts catalog is for easy identification of parts. All parts are illustrated in exploded views in proper relation to each other. Some diagrams refer to other pages for further information. Reference numbers used in the illustrations refer to line numbers in the part lists. The part lists appear to the right or below all diagrams and correspond with those diagrams. Included in the part lists, along with the reference numbers are part numbers, part descriptions and the quantity of the part required per leveling system.

ABBREVIATIONS

SN "Serial Number" refers to the serial number given to each leveling system (by Hillco Technologies), as well as the serial number given to the combine (by the specific combine manufacturer) the leveling system is installed. See above for the leveling system's serial number location. This abbreviation is used interchangeably in both instances. Each Model 2810 Leveling System uses the following serial number format: 2810-XXXX (sequential numbers).

ASM "Assembly" refers to a whole grouping of parts (shown in the diagram corresponding with the page where "ASM" is shown unless otherwise noted). Some assemblies have parts that are sold separately, however some must be purchased as a single unit. Hillco Product Specialists will be able to assist you with any questions.

NS "Not Shown" refers to a part that is not depicted in the illustration.

RIGHT AND LEFT IDENTIFICATION

The reference to right-hand and left-hand in this catalog is identified by the operator sitting in the operator's seat, looking toward the front of the machine (in normal forward travel).

PARTS ORDERS

Orders must specify product model, serial number, correct part number, complete description, quantity required, method of shipment, shipping address, and billing address.

2 TRANSITION

SEE PAGE 2-3 FOR
TRANSITION FASTENERS

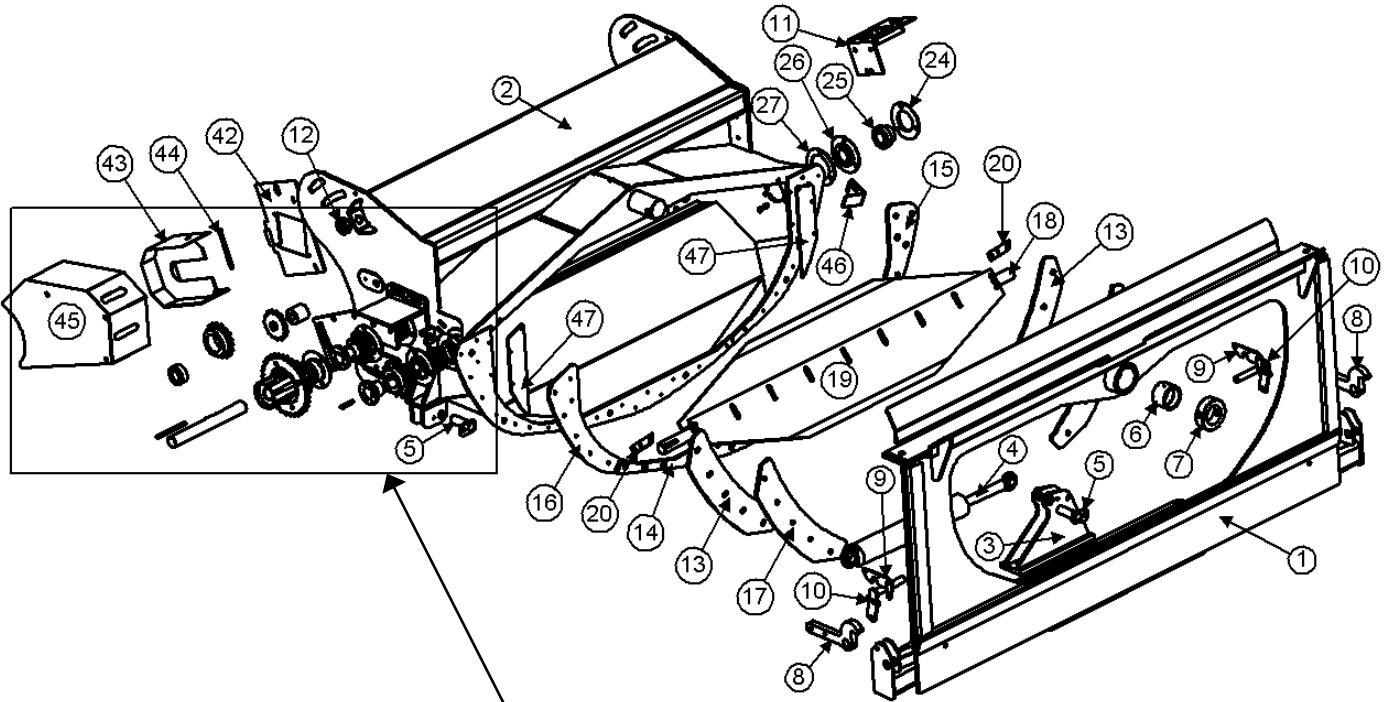

DRIVE COMPONENT DETAIL

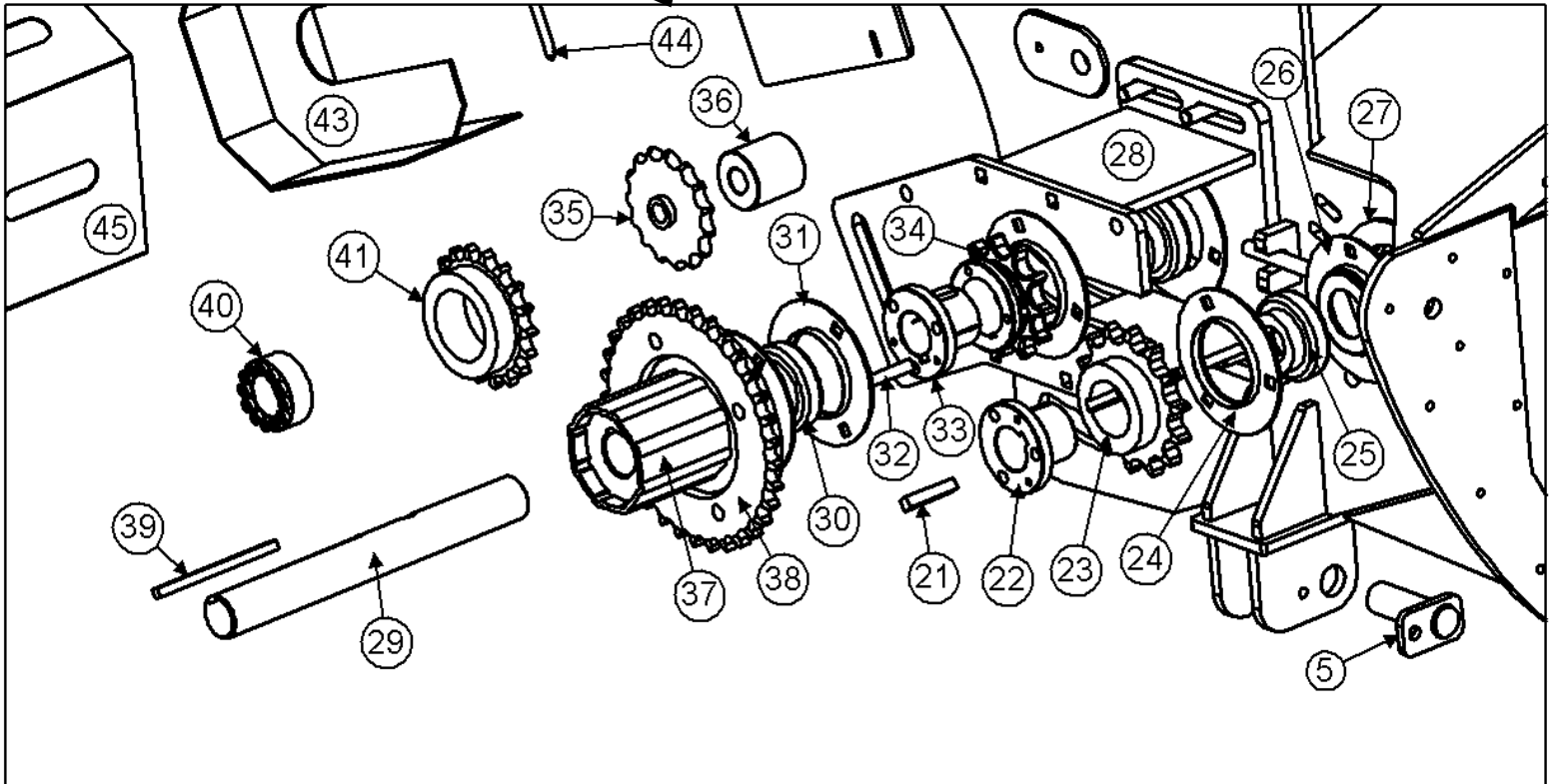

Model 2810 Hillco Leveling System
For Serial Numbers 2810-1301 thru 2810-1399

TRANSITION COMPONENTS				
REF.	PART NO.	QTY.	PART NAME	NOTES
1	LA-251512	1	TA ASM	
2	LA-251624	1	TT ASM	
3	LA-255141	1	TM MOUNT ASM, ROD	
4	HC-100706	1	CYLINDER, SLAVE	SEE HYDRAULIC PAGE 7-1
5	LA-229071	2	TM PIN ASM, TRIM CYLINDER	
6	LTP-241721	1	BUSHING, PIVOT	
7	LM-226841	1	TM COLLAR, PIVOT	
8	LM-250641	2	TM ARM, HEADER LOCK	
9	LM-262951	2	TM PLATE, HEADER LATCH	
10	LA-262981	2	TM ASM, HEADER LOCK	
11	LA-253621	1	TM ASM, HYDRAULIC COUPLER	
12	LM-251791	2	TM SPACER, EYEBOLT	
13	LP-249871	2	TM UHMW, BACKING	
14	LM-255181	1	TM PLATE, WEAR BOTTOM	
15	LM-255191	1	TM PLATE, WEAR LH	
16	LM-255201	1	TM PLATE, WEAR RH	
17	LM-255121	2	TM PLATE, BACKING	
NS	MC-145461	1	SPRING, TORSION, LH WIND	HEADER LOCK LATCH
NS	MC-145471	1	SPRING, TORSION, RH WIND	HEADER LOCK LATCH
BEATER SHAFT				
18	LA-251632	1	TB ASM, SHAFT	MUST BE USED WITH METAL PADDLES
19	LM-251002	2	TB PADDLE, METAL	NOT SUITABLE FOR CORN
20	LM-262811	2	TM STRIPPER, BEATER SHAFT	
21	LS-212701	1	TM KEY, BEATER DRIVE	
22	MC-135511	1	HUB, SPLIT TAPER 1-7/16	
23	MC-136151	1	SPROCKET, 80P, 14T TAPER BORE	
24	MC-101339	1	FLANGETTES, RND BEARING (PAIR)	
25	MC-100548	2	INSERT, BEARING, 1-7/16	
26	LA-243691	2	TM ASM, INNER FLANGETTE	
27	LP-263111	2	TM SPACER, BEATER BEARING	
NS	LM-213243	1	TM CHAIN, 30 PIN 80P	
NS	MC-142871	1	LINK, CONNECTING, 80P	
NS	MC-142881	1	LINK, OFFSET, 80P	
TRANSITION THROAT JACK SHAFT				
28	LA-251322	1	TM ASM, JS MOUNT	
29	LM-251771	1	TT SHAFT, JACK	
30	MC-100548	2	INSERT, BEARING, 1-7/16	
31	MC-101339	2	FLANGETTES, RND BEARING (PAIR)	
32	LS-212701	1	TM KEY, JACK SHAFT	
33	MC-135511	1	HUB, SPLIT TAPER 1-7/16	
34	MC-135491	1	SPROCKET, 80P, 11T TAPER BORE	
35	MC-100237	1	SPROCKET, IDLER, 60P, 15T, 5/8B	
36	LM-251881	1	TM SPACER, 60P IDLER SPROCKET	
37	LA-259821	1	RADIAL PIN SLIP CLUTCH	1050 Nm
38	LM-226532	1	TM SPROCKET, RADIAL SLIP CLUTCH	
39	LM-244471	1	TM KEY, RADIAL SLIP CLUTCH	
40	MC-101838	1	HUB, POWER LOCK, 1-3/8B	
NS	MC-145481	2	DRAW LATCH, RUBBER	
NS	LP-251783	1	TM CHAIN, 70 PIN 60P	
NS	MC-139361	1	LINK, CONNECTING, 60P	
NS	MC-139371	1	LINK, OFFSET, 60P	
FEEDER HOUSE BEATER DRIVE				
41	LM-255211	1	TM SPROCKET, POWERLOCK, 18T 60P	
42	LA-263061	1	TM SHIELD ASM, REAR DRIVE INNER	
43	LA-263071	1	TM SHIELD ASM, REAR DRIVE OUTER	
44	LM-263091	1	TM RND, SHIELD PIVOT	
45	LM-253862	1	TM SHIELD, MAIN DRIVE	
OPTIONAL FOR COMBINES HARVESTING LEGUMES (PEAS, LENTILS, GARBANZO BEANS, FLAX)				
46	LA-259881	2	TM ASM, ANTI-WRAP	
47	LM-259861	2	TM PLATE, NARROWING	
OPTIONAL FOR COMBINES HARVESTING GRASS				
NS	LM-262031	2	TM FLAT, TARP HOLDER	
NS	LP-262041	2	TM COVER, GRASS	

Model 2810 Hillco Leveling System
For Serial Numbers 2810-1301 thru 2810-1399

RADIAL PIN SLIP CLUTCH

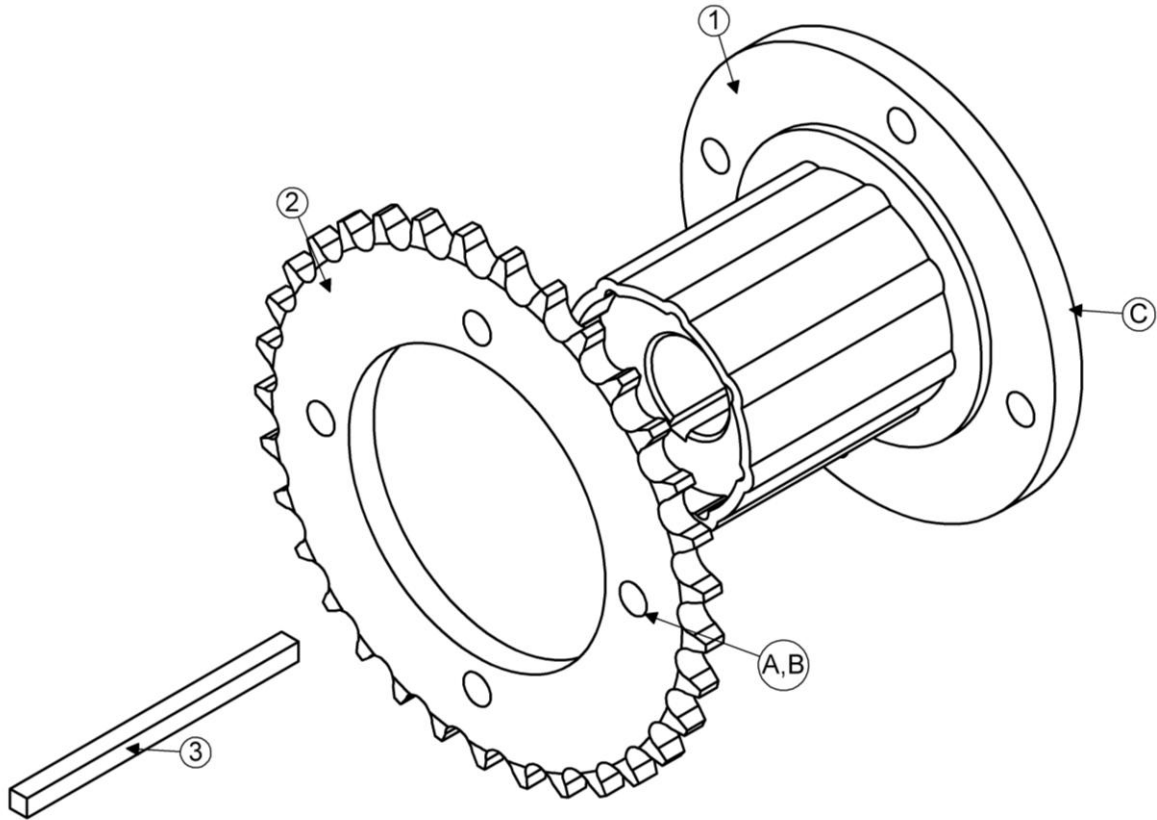

Model 2810 Hillco Leveling System
For Serial Numbers 2810-1301 thru 2810-1399

RADIAL PIN SLIP CLUTCH				
REF.	PART NO.	QTY.	PART NAME	DESCRIPTION
1	LA-259821	1	RADIAL PIN SLIP CLUTCH	1050 Nm
2	LM-226532	1	TM SPROCKET, RADIAL SLIP CLUTCH	
3	LM-244471	1	TM KEY, RADIAL SLIP CLUTCH	
RADIAL PIN SLIP CLUTCH FASTENERS				
REF.	PART NO.	QTY.	PART NAME	WHERE USED
A	F-HC8-08F20	4	HC8 1/2-20 X 1-1/4	
B	F-LWH-08	4	LW 1/2 HD	
C	F-SSS-06C08	2	SCREW, SOCKET SET 3/8-16 X 1/2	

Model 2810 Hillco Leveling System
For Serial Numbers 2810-1301 thru 2810-1399
TRANSITION FASTENERS

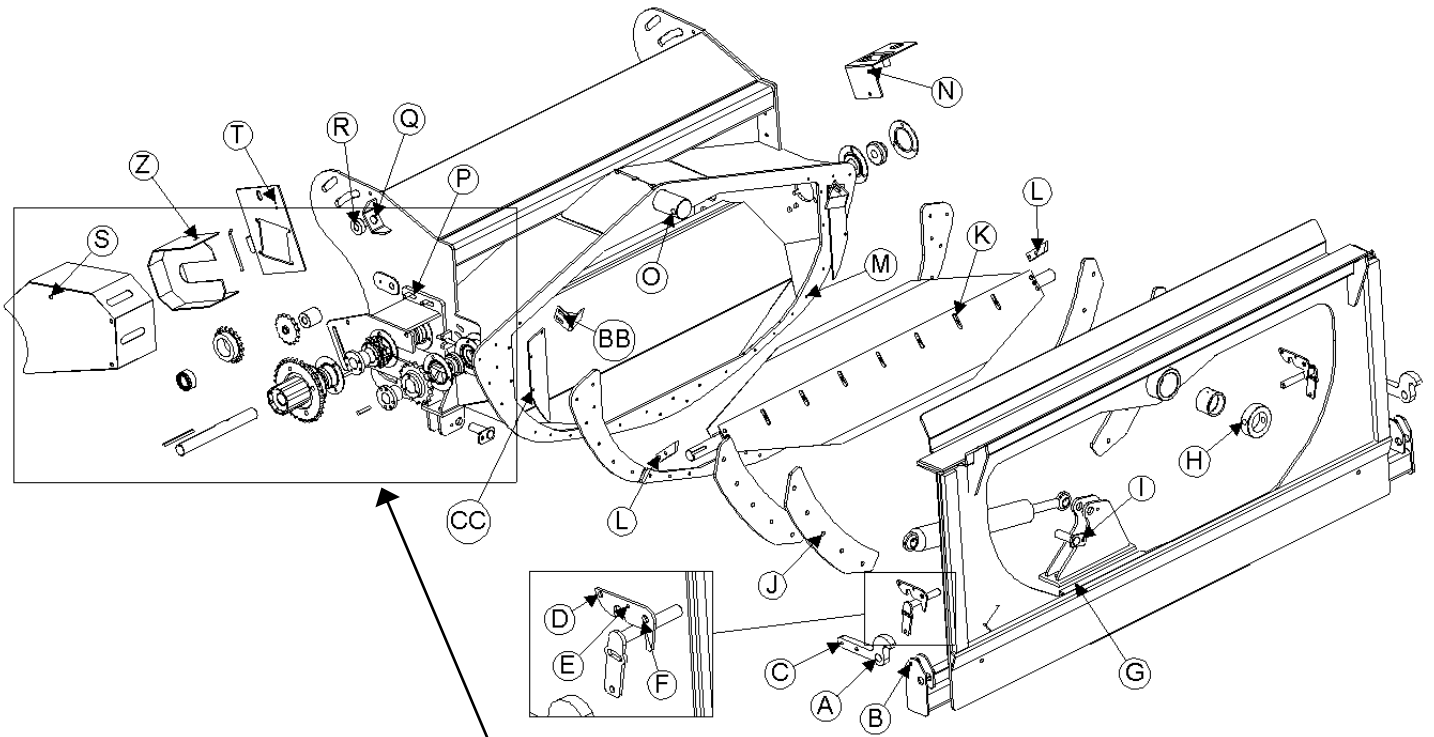

DRIVE COMPONENT FASTENERS DETAIL

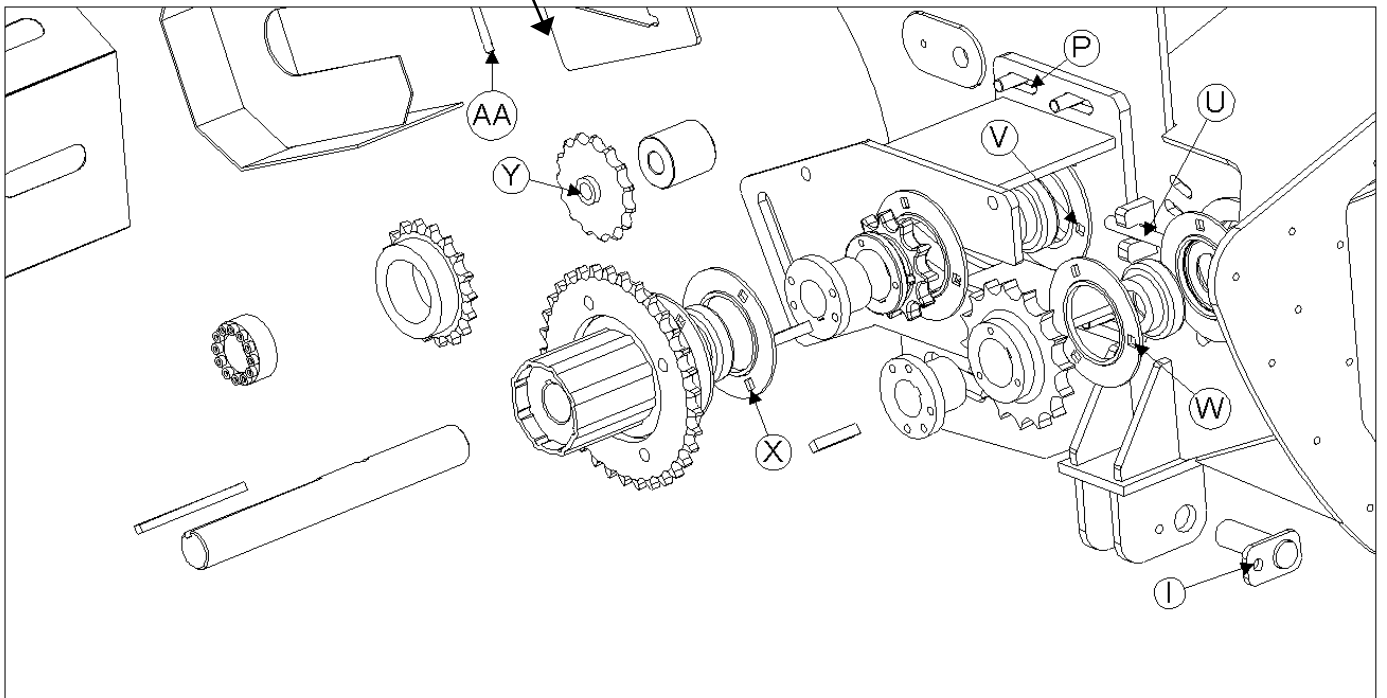

Model 2810 Hillco Leveling System
For Serial Numbers 2810-1301 thru 2810-1399

TRANSITION FASTENERS				
REF.	PART NO.	QTY.	PART NAME	WHERE USED
A	F-PCL-16X32	2	PIN, CLEVIS, 1 X 2	HEADER LOCK ARM
A	F-PCT-03X32	2	PIN, COTTER, 3/16 X 2	HEADER LOCK ARM
B	F-PQR-08X32	2	PIN, QUICK RELEASE	HEADER LOCK ARM
C	F-HCF-10M040E	4	FLHC-10.0 M10 X 1.50 X 40	HEADER LOCK ASM TO ARM
C	F-HNSF-10ME	4	FLHN-10.9 M10 X 1.50 STOVER	HEADER LOCK ASM TO ARM
D	F-PR-06X40	2	PIN, ROLL, 3/8 X 2-1/2 PLT	HEADER LOCK LATCH
E	F-HC-06M020F	2	HC-8.8 M6 X 1.00 X 20	HEADER LOCK LATCH TORSION SPRING
E	F-HNF-06ME	2	FLHN-10.9 M6 X 1.00	HEADER LOCK LATCH TORSION SPRING
F	F-PCT-02X16	2	PIN, COTTER, 1/8 X 1	HEADER LOCK LATCH CLEVIS PIN
F	F-PCL-08X32	2	PIN, CLEVIS, 1/2 X 2 PLT	HEADER LOCK LATCH PIVOT
G	F-HC-16M050E	3	HC-10.9 M16 X 2.00 X 50	ROD MNT
G	F-HNS-16ME	3	HN-10.9 M16 X 2.00 STOVER	ROD MNT
H	F-HC-16M120E	1	HC-10.9 M16 X 2.00 X 120	TT PIVOT PIN COLLAR
H	F-HNS-16ME	1	HN-10.9 M16 X 2.00 STOVER	TT PIVOT PIN COLLAR
I	F-HCF-10M020E	2	FLHC-10.9 M10 X 1.50 X 20	SLAVE CYLINDER MOUNT PIN
J	F-HCF-12M040E	10	FLHC-10.9 M12 X 1.75 X 40	BACKING PLATES
K	F-HNSF-12ME	9	FLHN-10.9 M12 X 1.75 STOVER	STEEL PADDLES
K	F-HCF-12M080E	9	FLHC-10.9 M12 X 1.75 X 80	STEEL PADDLES
L	F-HCF-12M020E	4	FLHC-10.0 M12 X 1.75 X 20	BEATER SHAFT STRIPPERS
M	F-FHS-8M016E	29	FHSC-10.9 M8 X 1.25 X 16	TT FACE PLATE
N	F-HCF-10M025E	2	FLHC-10.9 M10 X 1.50 X 25	HDR HYDRAULIC COUPLER MNT
N	F-HNF-10ME	2	FLHN-10.9 M10 X 1.50	HDR HYDRAULIC COUPLER MNT
O	F-MB-14NR40	3	BUSHING, MACH 14 GA, NR, 2 1/2" ID	TT PIVOT PIN
P	F-HNF-12ME	4	FLHN-10.9 M12 X 1.75	TT 80P CHAIN ADJUSTER
Q	F-EYB-20M150E	2	EYEBOLT M20 X 2.50 X 150	ANGLE ADJUSTMENT
Q	F-HNF-20ME	4	FLHN-10.9 M20 X 2.50	ANGLE ADJUSTMENT
R	F-CB-12C56	2	CARR-GR. 5 3/4-10 X 3-1/2	ANGLE ADJUSTMENT
R	F-HNF-12C	2	FLHN-GR. 5 3/4-10	ANGLE ADJUSTMENT
S	F-HNF-10ME	12	FLHN-10.9 M10 X 1.50 PLT	MAIN BEATER DRIVE SHIELD
S	F-HNJ-10MF	3	HN-8.8 M10 X 1.5 JAM PLT	MAIN BEATER DRIVE SHIELD
S	LM-263021	3	TM ALL THREAD	MAIN DRIVE SHIELD
T	F-HCF-08M025E	4	FLHC-10.9 M8 X 1.25 X 25	REAR TRANSITION DRIVE SHIELD
T	F-HNS-08ME	4	HN-10.9 M8 X 1.25 STOVER	REAR TRANSITION DRIVE SHIELD
U	F-FWH-08	2	FW 1/2 HD YELLOW	TT 80P CHAIN ADJUSTER
U	F-HNJ-12MF	2	HN-8.8 M12 X 1.75 JAM	TT 80P CHAIN ADJUSTER
V	F-HCF-10M016F	3	FLHC-8.8 M10 X 1.50 X 16	INNER JACKSHAFT BEARING
W	F-CB-10M030F	6	CARR-8.8 M10 X 1.50 X 30	TT BEATER BRNG
W	F-HNF-10MF	6	FLHN-8.8 M10 X 1.50	TT BEATER BRNG
X	F-CB-10M030F	3	CARR-8.8 M10 X 1.50 X 30	OUTER JACKSHAFT BEARING
X	F-HNF-10MF	3	FLHN-8.8 M10 X 1.50	OUTER JACKSHAFT BEARING
Y	F-HC-16M110E	1	HC-10.9 M16 X 2.0 X 110	60P IDLER SPROCKET
Y	F-HNS-16ME	1	HN-10.9 M16 X 2.0 STOVER	60P IDLER SPROCKET
Y	F-FWH-10	5	FW 5/8 HD	60P IDLER SPROCKET
Z	F-PHM-#6C08	6	PHMS #6-32 X 1/2	BOLT DRAW LATCH TO SHIELD
Z	F-HNF-#6C	6	FLHN #6-32	BOLT DRAW LATCH TO SHIELD
AA	F-PCT-02X16	1	PIN, COTTER, 1/8 X 1	SHIELD PIVOT PIN
OPTIONAL FOR COMBINES HARVESTING LEGUMES (PEAS, LENTILS, GARBANZO BEANS, FLAX)				
BB	F-HCF-10M025E	4	FLHC-10.9 M10 X 1.50 X 25	ANTI-WRAP ASSEMBLIES
BB	F-HNF-10ME	4	FLHN-10.9 M10 X 1.50	ANTI-WRAP ASSEMBLIES
CC	F-HC-06M020F	6	HC-8.8 M6 X 1.0 X 20	THROAT NARROWING PLATE
CC	F-HNF-06MF	6	FLHN-8.8 M6 X 1.0	THROAT NARROWING PLATE

Model 2810 Hillco Leveling System
For Serial Numbers 2810-1301 thru 2810-1399
WHEEL, WHEEL SPACER & WHEEL WASHER

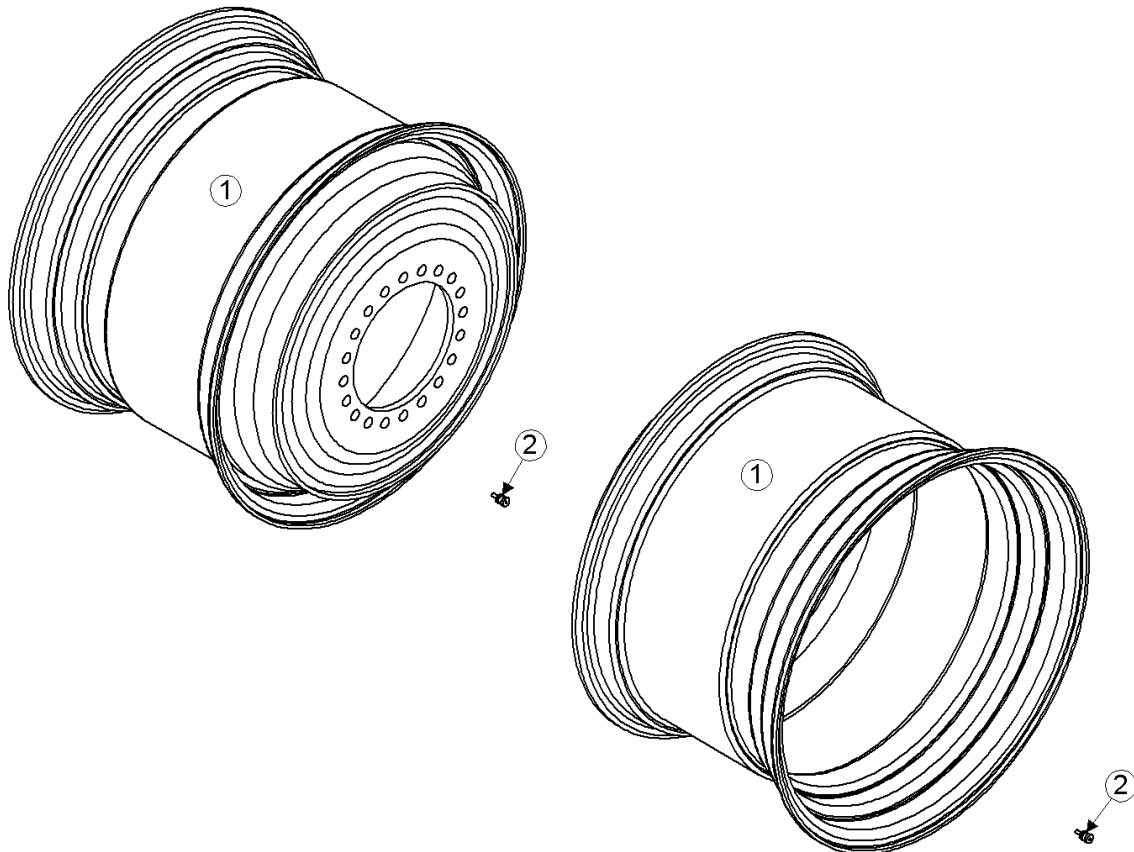

Model 2810 Hillco Leveling System
For Serial Numbers 2810-1301 thru 2810-1399

WHEEL COMPONENTS				
REF.	PART NO.	QTY.	PART NAME	DESCRIPTION
1	MC-143121	4	32 X 21 SINGLE PIECE WHEEL	
2	MC-143921	4	VALVE STEM	
WHEEL FASTENERS				
REF.	PART NO.	QTY.	PART NAME	NOTES
NS	N/A	20	BOLT	CASE PART NUMBER 87283525
NS	N/A	10	SPACER PLATE	CASE PART NUMBER 87253501
NS	N/A	20	NUT	CASE PART NUMBER 336845

3 CARRIAGE

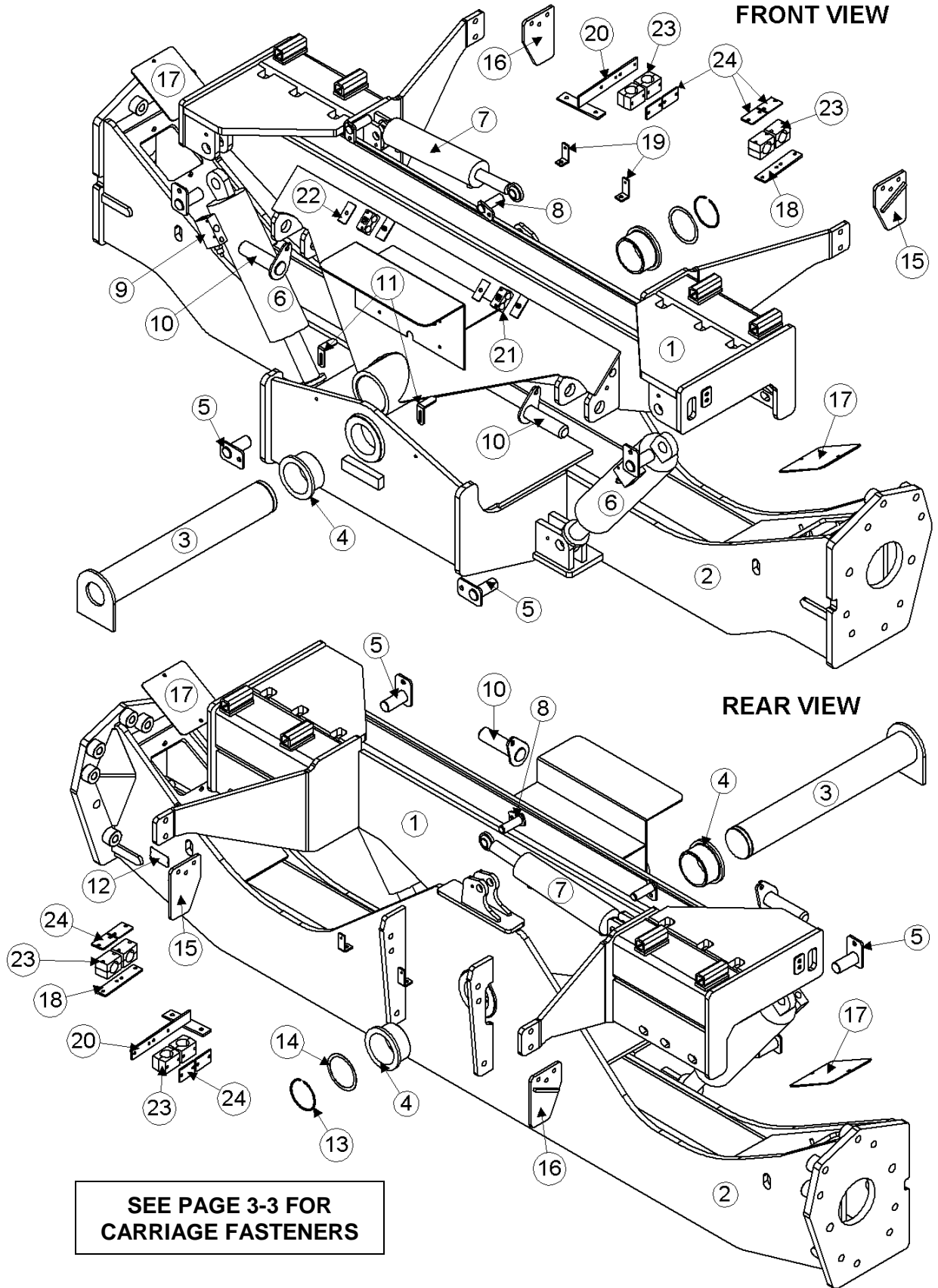

**SEE PAGE 3-3 FOR
CARRIAGE FASTENERS**

Model 2810 Hillco Leveling System
For Serial Numbers 2810-1301 thru 2810-1399

CARRIAGE COMPONENTS				
REF.	PART NO.	QTY.	PART NAME	DESCRIPTION
1	LA-251491	1	CO ASM	
2	LA-251531	1	CU ASM	
3	LA-247481	1	CM ASM, MAIN PVT PIN	
4	LP-251071	2	CO BUSHING, PIVOT	
5	LA-230551	4	CM PIN ASM, MAIN CYLINDER	
6	HC-102218	2	CYLINDER, MAIN	SEE HYDRAULICS PAGE 7-1
7	HC-101842	1	CYLINDER, MASTER	SEE HYDRAULICS PAGE 7-1
8	LA-229071	2	TM PIN ASM, TRIM CYLINDER	
9	HC-139151	2	VALVE, 3-PORT COUNTERBALANCE	SEE HYDRAULICS PAGE 7-1
10	LM-255301	2	CM PIN, HEADER LIFT CYLINDER	
11	LP-251551	2	EM PLATE, LIMIT STOP	
12	LA-255951	1	PLATE, SERIAL NUMBER	
13	MC-138651	1	SNAP RING 4"	
14	MC-138641	1-4	WASHER, 4.016" ID X 4.764" OD X .48	
15	LA-251471	1	CM ASM, LEFT SWING ARM MOUNT	
16	LA-251481	1	CM ASM, RIGHT SWING ARM MOUNT	
17	LP-251461	2	CM PLATE, FINAL BOLT COVER	
NS	MC-137501	?	WASHER, QUICK REPAIR 2"	OPTIONAL -- SAFETY STOP -- QTY. AS NEEDED
NS	MC-137251	?	COLLAR, 2-PIECE CLAMPING 2" BORE	OPTIONAL -- SAFETY STOP -- QTY. AS NEEDED
MISCELLANEOUS CARRIAGE COMPONENTS				
REF.	PART NO.	QTY.	PART NAME	DESCRIPTION
18	LM-251861	1	HM FLAT, HYDRO HOSE BRACKET	
19	LM-251871	2	HM MOUNT, BRAKE LINE	
20	LA-251831	1	HM ASM, HYDRO HOSE BRACKET	
21	HC-140461	2	BEHRINGER TWIN CLAMP .875 DIAMETER	ON OC HOSES BETWEEN CYLINDERS
22	HC-139451	2	BEHRINGER TWIN COVER PLATE (FOR .875)	ON OC HOSES BETWEEN CYLINDERS
23	HC-140641	4	BEHRINGER STD. CLAMP 2" DIAMETER	HYDRO HOSES
24	HC-140651	4	BEHRINGER STD. COVER PLATE	HYDRO HOSES
NS	EC-142101	2	CLAMP, HOSE, R/C, 3/8	BRAKE HOSES

Model 2810 Hillco Leveling System
For Serial Numbers 2810-1301 thru 2810-1399

CARRIAGE FASTENERS

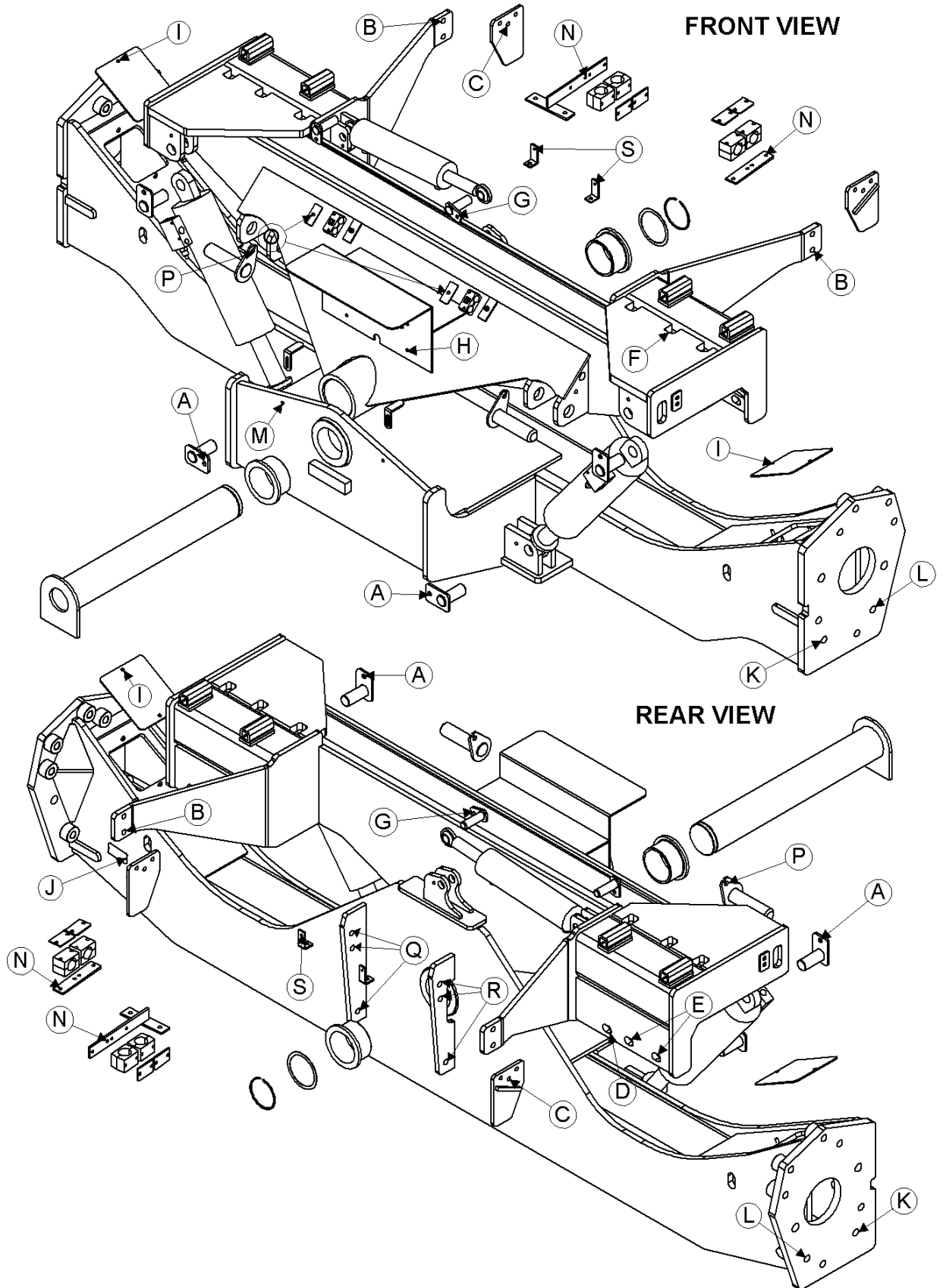

Model 2810 Hillco Leveling System
For Serial Numbers 2810-1301 thru 2810-1399

CARRIAGE FASTENERS				
REF.	PART NO.	QTY.	PART NAME	WHERE USED
A	F-HCF-12M025F	4	FLHC-8.8 M12 X 1.75 X 25	LEVELING CYL MNT PIN
B	F-HC-16M050E	4	HC-10.9 M16 X 2.00 X 50	OC SWING ARM PLATE
B	F-HNS-16ME	4	HN-10.9 M16 X 2.00 STV	OC SWING ARM PLATE
C	F-HCF-12M030E	6	FLHC-10.9 M12 X 1.75 X 30	SWING ARM MOUNTING BRACKET
C	F-HNF-12MF	6	FLHN-8.8 M12 X 1.75	SWING ARM MOUNTING BRACKET
D	F-HC-20M070E	2	HC-10.9 M20 X 2.5 X 70	OC REAR MOUNTING PLATE
E	F-HC-20M120	4	HC-10.9 M20 X 2.5 X 120	OC REAR MOUNTING PLATE
F	F-HC-20M280E	6	HC-10.9 M20 X 2.5 X 280	OC BOTTOM MOUNTING PLATE
G	F-HCF-10M020E	2	FLHC-10.9 M10 X 1.50 X 20	MASTER CYL MNT PIN
H	F-HCF-08M020E	4	FLHC-10.9 M8 X 1.25 X 20	ELECTRICAL ASM TO OC
H	F-HNF-08ME	4	FLHN-10.9 M8 X 1.25	ELECTRICAL ASM TO OC
I	F-HNF-8MF	4	FLHN-10.9 M8 X 1.25	UC FINAL BOLT COVER PLATES
J	F-UDS-#7X06	2	SCREW, U-DRIVE #7 X 3/8	SERIAL NUMBER PLATE
K	F-HC-20M090E	16	HC-10.9 M20 X 2.50 X 90	FINAL DRIVES
L	F-SHC-20M090E	2	SHCS- 10.9 M20 X 25 X 90	FINAL DRIVES
M	F-HC-8M040F	2	HC-8.8 M8 X 1.25 X 40	LIMIT SWITCH STOPS
M	F-HNF-08MF	2	FLHN-8.8 M8 X 1.25	LIMIT SWITCH STOPS
N	F-HC-6M090F	8	HC-8.8 M6 X 1.0 X 90	HYDRO HOSE CLAMPS
N	F-HNF-6MF	8	FLHN-8.8 M6 X 1.0	HYDRO HOSE CLAMPS
O	HC-139461	2	BEHRINGER TWIN BOLT (FOR .875) HC5 5/16-18 X 1-3/4	ON OC HOSES BETWEEN CYLINDERS
P	F-HC-12M040E	2	HC-10.9 M12 X 1.75 X 40	HEADER LIFT CYLINDER PINS
P	F-HNS-12ME	2	HN-10.9 M12 X 1.75 STV	HEADER LIFT CYLINDER PINS
Q	F-HC-16M050E	6	HC-10.9 M16 X 2.00 X 50	TRANSMISSION MOUNTING
R	MC-141961	6	SHIM, ALIGNMENT, 1/16	TRANSMISSION MOUNTING
R	MC-141971	3	SHIM, ALIGNMENT, 1/32	TRANSMISSION MOUNTING
R	MC-141981	3	SHIM, ALIGNMENT, 1/64	TRANSMISSION MOUNTING
S	F-HC-06M020F	2	HC-8.8 M6 X 1.0 X 20	BRAKE HOSES
S	F-HNF-6MF	2	FLHN-8.8 M6 X 1.0	BRAKE HOSES

Model 2810 Hillco Leveling System
For Serial Numbers 2810-1301 thru 2810-1399

4 DROP AXLE

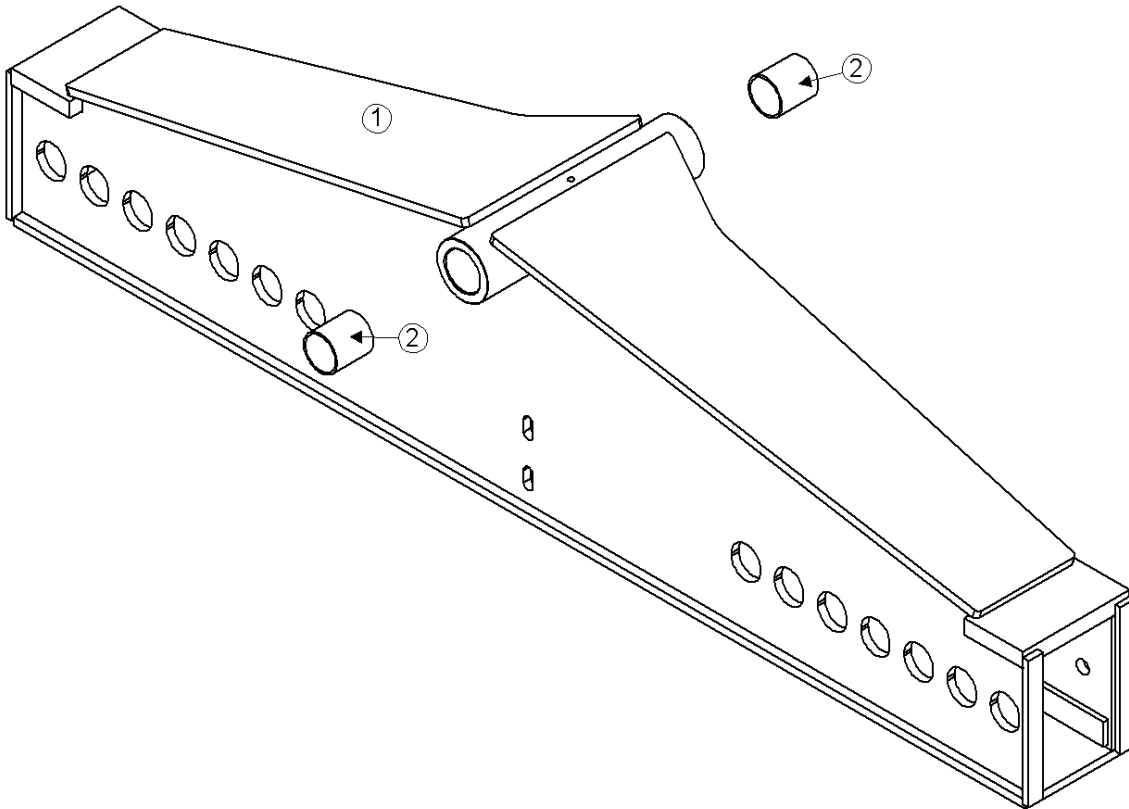

Model 2810 Hillco Leveling System
For Serial Numbers 2810-1301 thru 2810-1399

DROP AXLE COMPONENTS				
REF.	PART NO.	QTY.	PART NAME	DESCRIPTION
1	LA-252161	1	DA ASM	
2	MC-140791	2	REAR AXLE PIVOT SLEEVE	DROP AXLE PIVOT BUSHING
DROP AXLE FASTENERS				
**ALL FASTENERS USED ON THE DROP AXLE ARE ORIGINAL EQUIPMENT				

5 LADDER

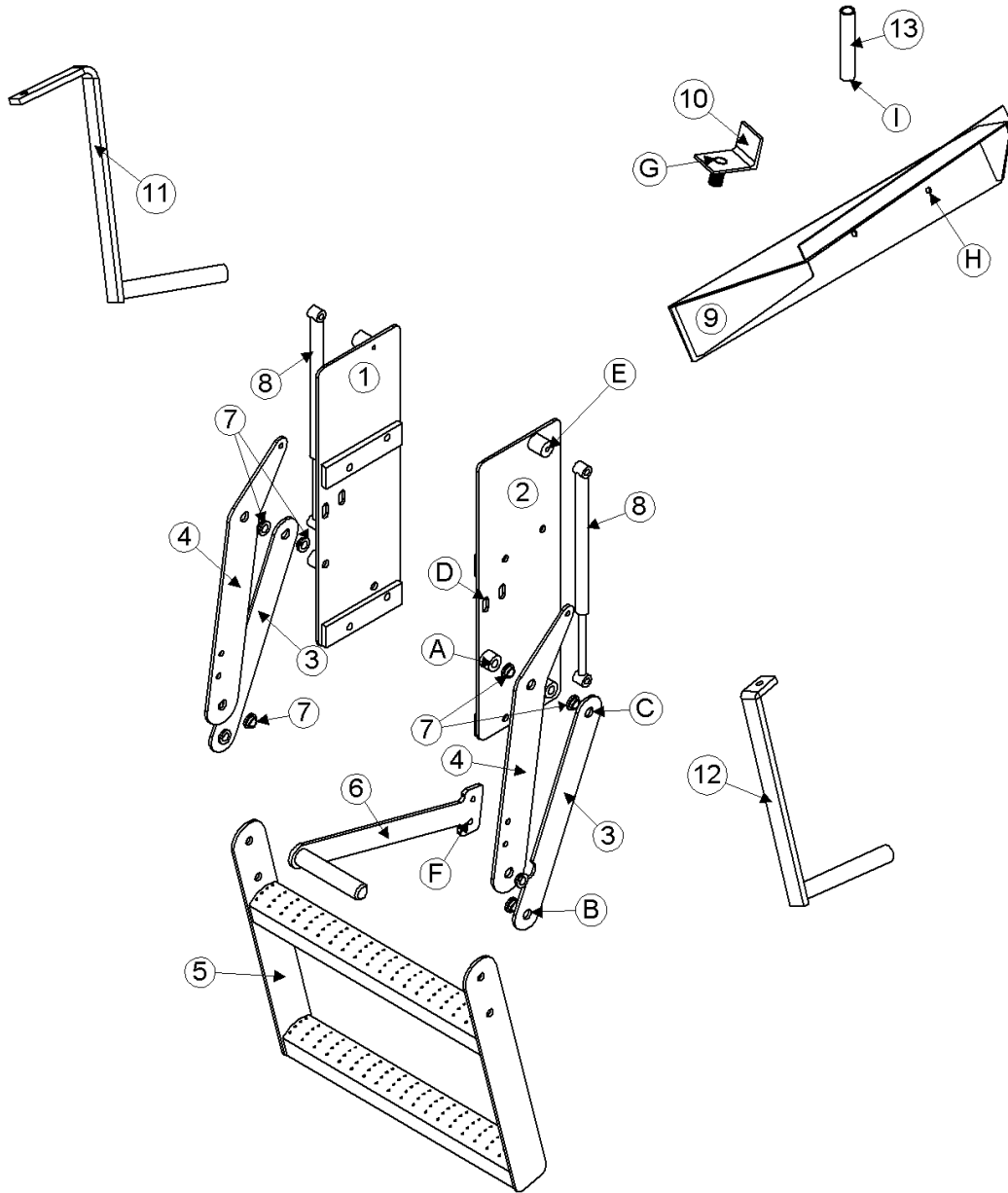

Model 2810 Hillco Leveling System
For Serial Numbers 2810-1301 thru 2810-1399

LADDER COMPONENTS				
REF.	PART NO.	QTY.	PART NAME	DESCRIPTION
1	LA-252332	1	LM ASM, LEFT LADDER MNT	
2	LA-252342	1	LM ASM, RIGHT LADDER MNT	
3	LM-252262	2	LM PLATE, FOLDING LADDER LINK	
4	LM-252272	2	LM PLATE, UPPER ARM	
5	LA-252322	1	LM STEP ASM, FOLDING LADDER	
6	LA-248861	1	LM ASM, LADDER HANDLE	
7	MC-134941	8	FLANGED BUSHING	
8	MC-139251	2	GAS CHARGED LIFT SUPPORT	
NS	MC-134931	2	LIFT SUPPORT BRACKETS (PAIR)	
9	LA-253901	1	LM ASM, LADDER WEDGE	
10	LA-253961	1	LM ASM, LADDER STOP	
11	LA-251801	1	LM ASM, RH SIDE STEP SUPPORT	
12	LA-255841	1	LM ASM, LH SIDE STEP SUPPORT	
13	LS-256381	1	LM SPACER, FLASHING LIGHT	
LADDER FASTENERS				
REF.	PART NO.	QTY.	PART NAME	WHERE USED
A	F-HC-12M050F	2	HC-8.8 M12 X 1.75 X 50	LADDER TOP SIDE PLATE PIVOTS
A	F-HNS-12ME	2	HN- 10.9 M12 X 1.75 STV	LADDER PIVOTS
B	F-HC-12M030F	4	HC-8.8 M12 X 1.75 X 30	LADDER MIDDLE PIVOTS
B	F-HNS-12ME	4	HN- 10.9 M12 X 1.75 STV	LADDER PIVOTS
C	F-HC-12M065F	2	HC-8.8 M12 X 1.75 X 65	LADDER BOTTOM SIDE PLT PIVOTS
C	F-HNS-12ME	2	HN- 10.9 M12 X 1.75 STV	LADDER PIVOTS
D	F-HC-10M040F	8	HC-8.8 M10 X 1.50 X 40	LADDER SIDE PLATE MOUNTS
D	F-HNS-10ME	8	HN-10.9 M10 X 1.50 STV	LADDER SIDE PLATE MOUNTS
E	F-HNJ-05C	2	HN5 5/16-18 JAM NUT	LADDER BALL STUD
E	F-LW-05	4	LW 5/16	LADDER BALL STUD
F	F-HC-08M025F	2	HC-8.8 M8 X 1.25 X 25	LADDER HANDLE
F	F-HNF-08MF	2	FLHN-8.8 M8 X 1.25	LADDER HANDLE
G	F-HN5-12C	1	HN5 3/4-10	LADDER STOP
G	F-LW-12	1	LW 3/4	LADDER STOP
H	F-HCF-8M020E	3	FLHC-10.9 M8 X 1.25 X 20	LADDER WEDGE
H	F-HNF-08ME	3	FLHN-10.9 M8 X 1.25	LADDER WEDGE
I	F-HC-12M280F	1	HC-8.8 M12 X 1.75 X 280	FLASHING LIGHT BRACKET

6 ELECTRICAL

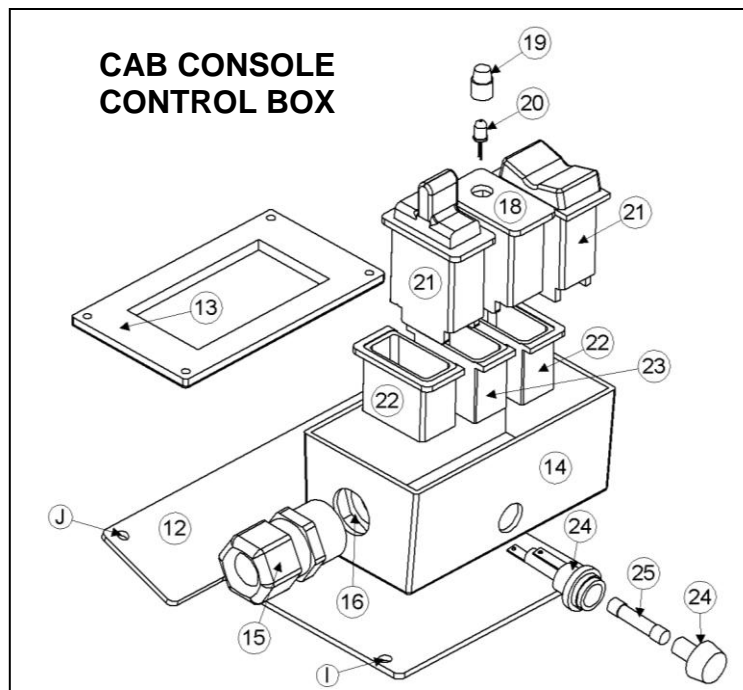
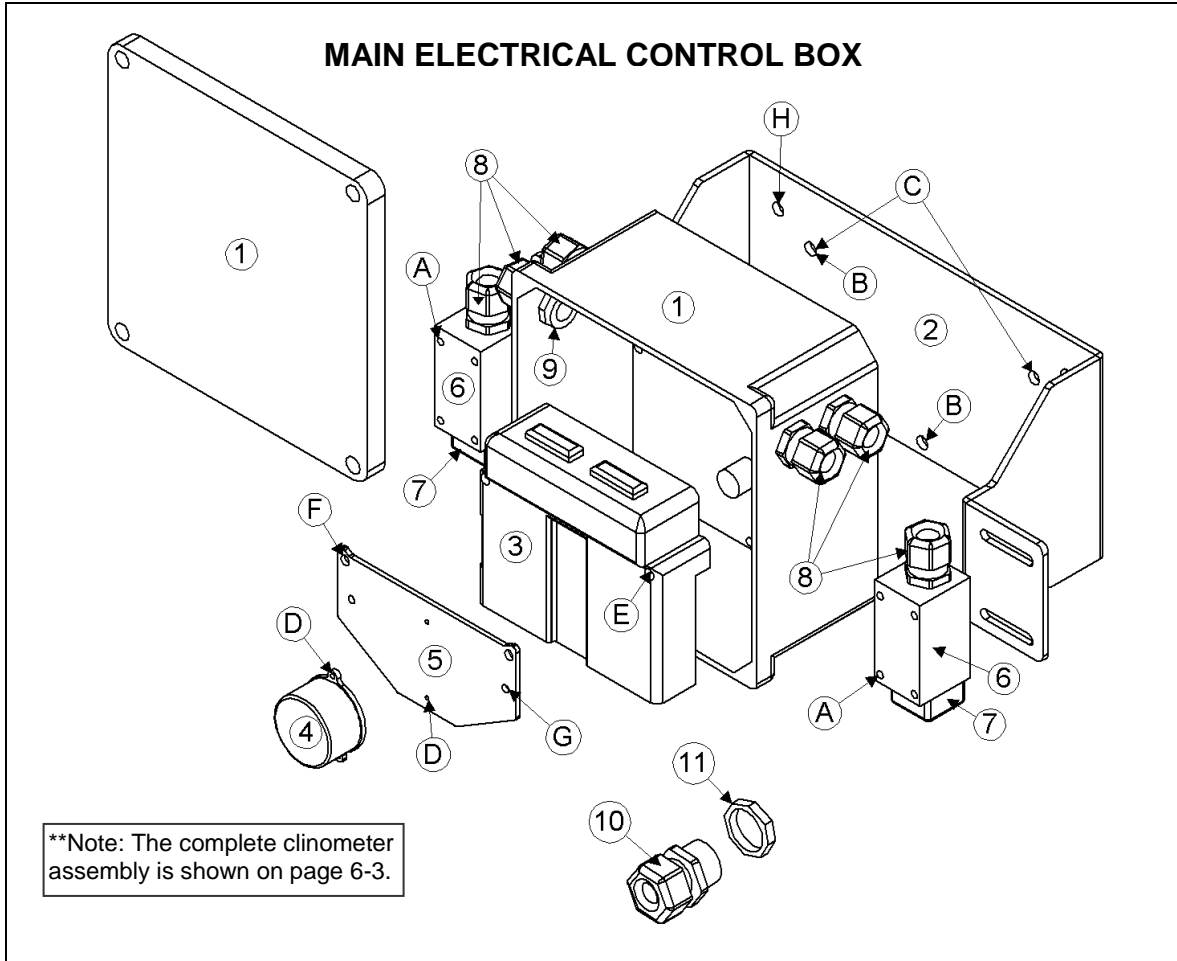

Model 2810 Hillco Leveling System
For Serial Numbers 2810-1301 thru 2810-1399

MAIN ELECTRICAL BOX COMPONENTS				
REF.	PART NO.	QTY.	PART NAME	NOTES
ASM	LA-254472	1	EM ASM, CONTROLLER	
1	LM-255341	1	EM BOX, CONTROLLER MOUNT	
2	LP-251432	1	EM MOUNT, LEVELING BOX	
3	EC-141831	1	CONTROLLER	
4	LA-255821	1	EM ASM, CLINOMETER	SEE NOTE BELOW DIAGRAM
5	LM-255331	1	EM SHT, CLINOMETER MOUNT	
6	EC-100557	2	BODY, LIMIT SWITCH	
7	EC-100692	2	HEAD, LIMIT SWITCH STR PLUNGER	
8	EC-138781	6	STRAIN RELIEF, NYLON, BLK, 1/2 NPT	
9	EC-142121	4	STRAIN RELIEF NUT, 1/2" NYLON, BLK	
10	EC-141891	1	STRAIN RELIEF, NYLON, BLK	BOTTOM OF CAB
11	EC-141901	1	STRAIN RELIEF NUT, NYLON, BLK	BOTTOM OF CAB
ELECTRICAL BOX FASTENERS				
REF.	PART NO.	QTY.	PART NAME	WHERE USED
A	F-PHM-5M050F	8	PHMS M5 X 0.8 X 50	LIMIT SWITCH MNT
A	F-HNF-5MF	8	FLHN-8.8 M5 X 0.8	LIMIT SWITCH MNT
B	F-HC5-04C12	3	HC5 1/4-20 X 3/4	PVC BOX TO BRACKET
B	F-LW-04	3	LW 1/4	PVC BOX TO BRACKET
C	F-HCF-08M020E	4	FLHC-10.9 M8 X 1.25 X 20	ELECTRICAL PLATE TO OC
C	F-HNF-08ME	4	FLHN-10.9 M8 X 1.25	ELECTRICAL PLATE TO OC
D	F-PHM-#6C06	2	PHMS #6-32 X 3/8	CLINOMETER MOUNT
E	F-PHM-04C24	2	PHMS 1/4-20 X 1-1/2	CONTROLLER TO PVC BOX
E	F-HNF-04C	2	FLHN 1/4-20 SERR	CONTROLLER TO PVC BOX
F	F-PHM-04C36	2	PHMS 1/4-20 X 2-1/4	GROUNDING PLATE MOUNTING
F	F-HNF-04C	2	FLHN 1/4-20 SERR	GROUNDING PLATE MOUNTING
G	F-PHM-#10C16	2	PHMS 10-24 X 3/4	GROUNDING PLATE GROUND
G	F-HNF-#10C	2	HN5 10-24, SERR	GROUNDING PLATE GROUND
G	F-HN-#10C	2	HN5 10-24	GROUNDING PLATE GROUND
H	F-LWE-05	1	LW 5/16, EXTERNAL STAR	EXTERNAL GROUND WIRE
CAB CONSOLE CONTROL BOX COMPONENTS				
REF.	PART NO.	QTY.	PART NAME	NOTES
ASM	LA-254452	1	EM ASM, CAB CONTROL BOX	
FOR AFX 8010 COMBINES WITH SN PRIOR TO HAJ200001				
NS	LM-251641	1	EM MOUNT, CAB CONSOLE	
FOR AFX 8010 COMBINES WITH SN HAJ200001 AND AFTER				
12	LM-263201	1	EM MOUNT, CAB CONSOLE	
FOR ALL COMBINES				
13	LM-252611X	1	EM LID, CAB CONTROL BOX	
14	LM-241122X	1	EM, CAB CONTROL BOX	
15	EC-138791	1	STRAIN RELIEF, NYLON, BLK	
16	EC-138801	1	STRAIN RELIEF NUT, NYLON, BLK	
17	LA-259671	1	SWITCH ASM, LEFT-RIGHT	
18	LM-252621	1	EM MOUNT, MAX LEVEL LAMP	
19	EC-140761	1	LENSE, YELLOW	
20	EC-140871	1	LED, WHITE	
21	LA-259661	1	SWITCH ASM, AUTO-OFF-MANUAL	
22	EC-140751	2	GANG MOUNT	
23	EC-140771	1	BEZEL, CENTER	
24	EC-136211	1	3AG FUSE HOLDER	
25	EC-136221	1	AGC-6A FUSE	
CAB CONSOLE CONTROL BOX FASTENERS				
REF.	PART NO.	QTY.	PART NAME	WHERE USED
I	F-PHM-#6C12	2	PHMS 6-32 X 3/4	CONSOLE BOX TO BRACKET
I	F-HNF-#6C	2	FLHN 6-32	CONSOLE BOX TO BRACKET
FOR AFX 8010 COMBINES WITH SN PRIOR TO HAJ200001				
J	F-PHM-4M030F	2	PHMS M4 X 0.7 X 30	CAB CONSOLE BOX BRACKET TO MONITOR
FOR AFX 8010 COMBINES WITH SN HAJ200001 AND AFTER				
J	F-PHM-6M020F	4	PHMS M6 X 1.0 X 20	CAB CONSOLE BOX BRACKET TO LARGE MONITOR
J	F-PHM-6M016F	4	PHMS M6 X 1.0 X 16	CAB CONSOLE BOX BRACKET TO SMALL MONITOR
J	F-FW-04	4	FW 1/4	CAB CONSOLE BOX BRACKET TO MONITOR

Model 2810 Hillco Leveling System
 For Serial Numbers 2810-1301 thru 2810-1399
ELECTRICAL CONNECTORS AND CABLES

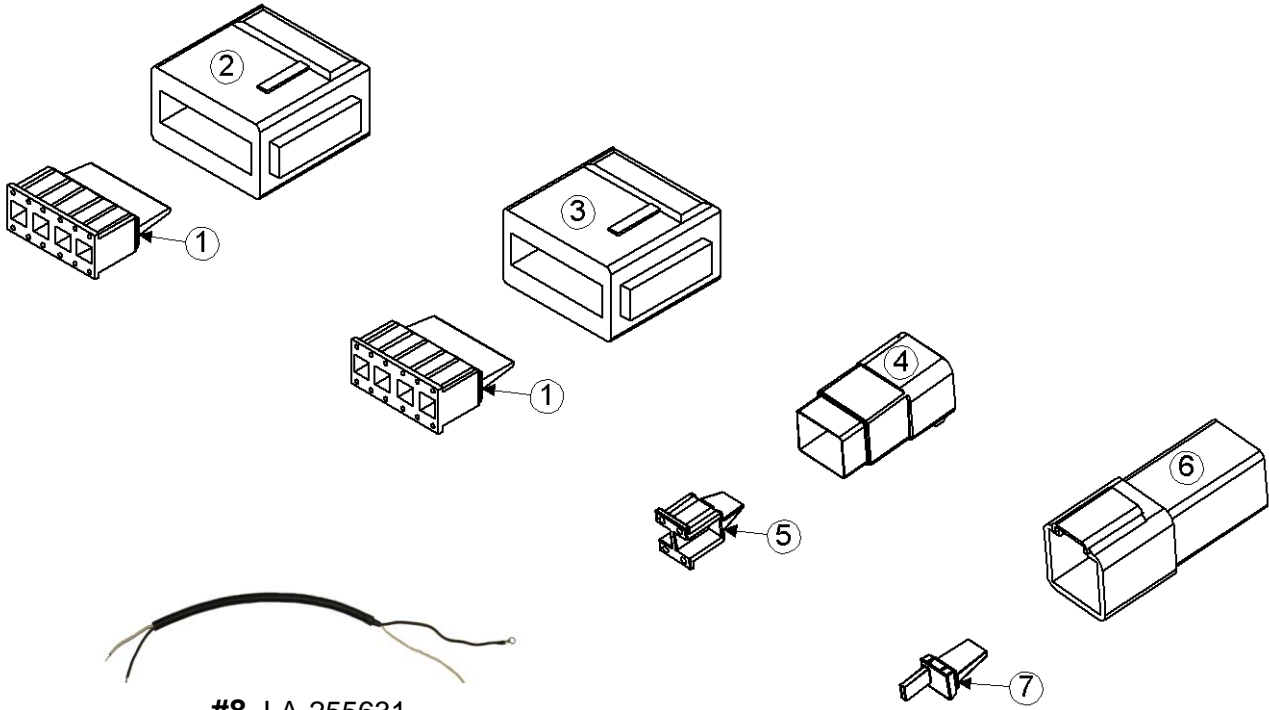

#8 LA-255631
 EM CABLE ASM, LIMIT SWITCH



#9 LA-249102
 EM CABLE ASM, BOX TO VALVE



#11 LA-249062
 EM CABLE ASM, LEVELING CABLE



#10 LA-255821
 EM ASM, CLINOMETER



#12 LA-255751
 EM CABLE ASM, CAB BOX TO VALVE

Model 2810 Hillco Leveling System
For Serial Numbers 2810-1301 thru 2810-1399

ELECTRICAL CONNECTORS				
REF.	PART NO.	QTY.	PART NAME	NOTES
1	EC-141741	2	DTM SERIES 12-SOCKET WEDGE	
2	EC-141751	1	DTM SERIES 12-SOCKET PLUG-GRAY	
3	EC-141761	1	DTM SERIES 12-SOCKET PLUG-BLACK	
4	EC-141791	1	DTM SERIES 4-SOCKET PLUG	
5	EC-141801	1	DTM SERIES 4-SOCKET WEDGE	
NS	EC-141771	17	DTM SERIES SOCKET, CONTACT STAMPED	
6	EC-141811	1	DTM SERIES 4-PIN RECEPTACLE	
7	EC-141821	1	DTM SERIES 4-PIN WEDGE	
NS	EC-141781	4	DTM SERIES PIN, CONTACT STAMPED	
NS	ET-ST-20#10	6	TERMINAL, RING, #10, 20 GA., NON-INSULATED	
NS	ET-ST-2005	1	TERMINAL, RING, NON-INS, 5/16, 20 GA	
NS	EC-140891	16	SPADE, FEMALE, INSULATED, 16-22 GA	
NS	EC-139641	4	CONNECTOR, PARALLEL 16-14 GA.	
NS	ET-SP-20	2	TERMINAL, FEMALE SPADE, NON-INSUL, 20 GA	
NS	EC-100008	1	TERMINAL, RELAY, AUTOMOTIVE	
CABLE ASSEMBLIES				
REF.	PART NO.	QTY.	PART NAME	NOTES
8	LA-255631	2	EM CABLE ASM, LIMIT SWITCH	
9	LA-249102	1	EM CABLE ASM, BOX TO VALVE	
10	LA-255821	1	EM ASM, CLINOMETER	
11	LA-249062	1	EM CABLE ASM, LEVELING CABLE	
12	LA-255751	1	EM CABLE ASM, CAB TO BOX	
NS	LA-265481	1	EM CABLE ASM, SENSOR ADAPTER	

7 HYDRAULICS

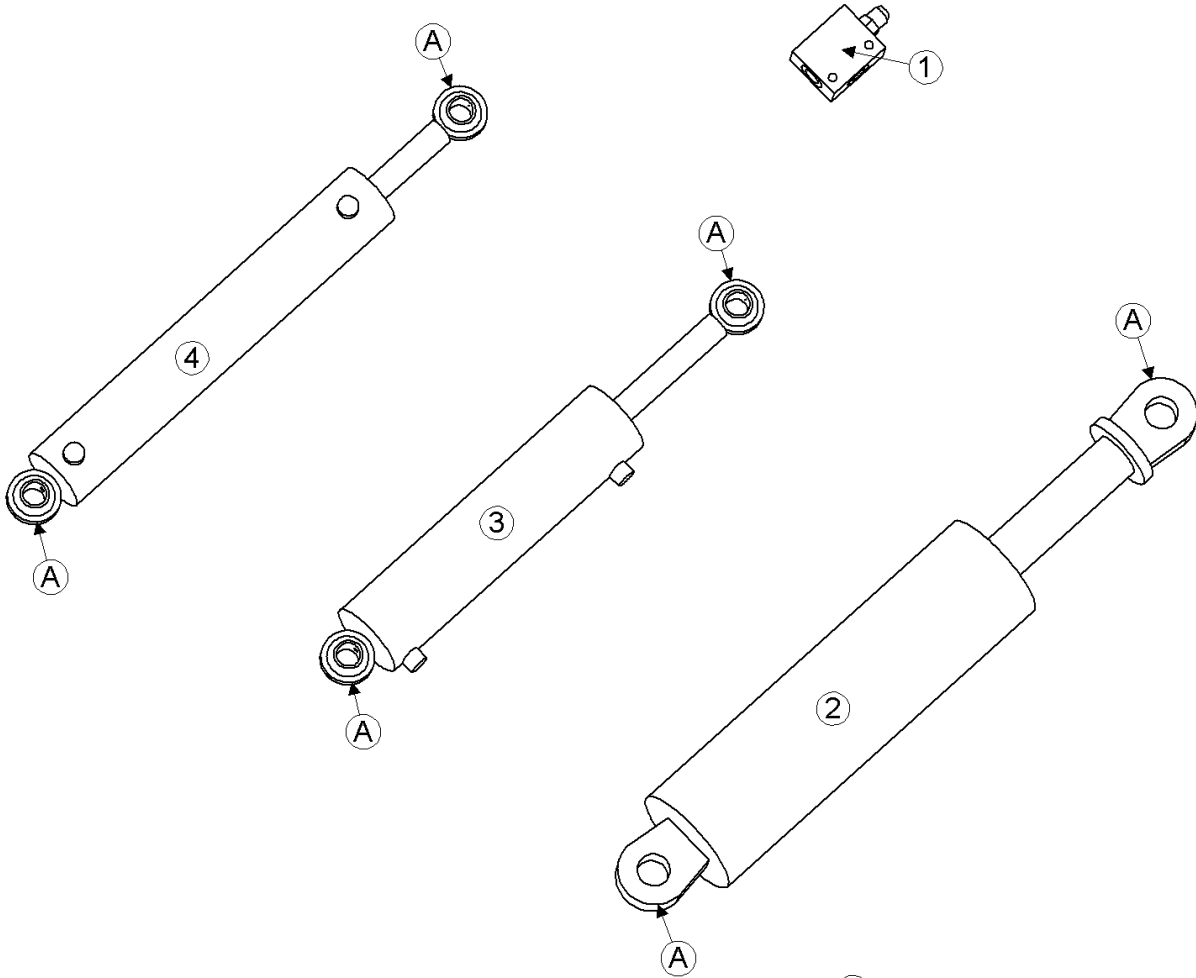

**CODE 62 SPLIT FLANGE
CONNECTOR KIT
ASSEMBLY WITH O-RINGS**

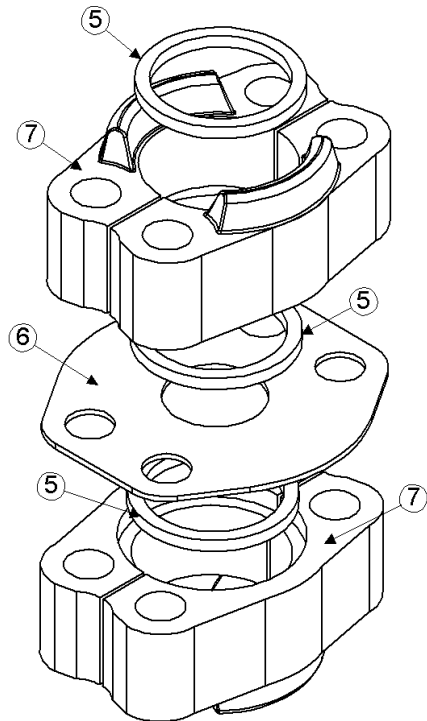

Model 2810 Hillco Leveling System
For Serial Numbers 2810-1301 thru 2810-1399

COUNTERBALANCE VALVE AND CYLINDERS				
REF.	PART NO.	QTY.	PART NAME	DESCRIPTION
1	HC-139151	2	VALVE, 3-PORT COUNTERBALANCE	
..	HC-139181	2	BODY, COUNTERBALANCE VALVE	
..	HC-139161	2	CARTRIDGE, COUNTERBALANCE VALVE	
NS	HC-140361	2	SEAL KIT, COUNTERBALANCE VALVE	
2	HC-102218	2	CYLINDER, MAIN	
NS	HC-135221	2	SEAL KIT, MAIN CYLINDER	
3	HC-101842	1	CYLINDER, MASTER	
NS	HC-134201	1	SEAL KIT, MASTER CYLINDER	
4	HC-100706	1	CYLINDER, SLAVE	
NS	HC-134191	1	SEAL KIT, SLAVE CYLINDER	
HYDRAULIC FASTENERS				
REF.	PART NO.	QTY.	PART NAME	WHERE USED
A	F-SSS-04F04	6	SET SCREW, 1/4-28 X 1/4	ALL CYLINDERS
CODE 62 SPLIT FLANGE CONNECTOR KIT				
ASM	LA-254951	2	KIT, HOSE COUPLER, 1-1/4" CODE 62	
5	HC-140431	6	O-RING, CODE 62 CONNECTOR (SQUARE) #20	
6	HC-140441	2	PLATE, CODE 62,#20	
7	HC-140451	4	CODE 62, #20 SPLIT FLANGE KIT	
NS	F-HC-12M070E	8	HC-10.9 M12 X 1.75 X 70	
NS	F-HNS-12ME	8	HN-10.9 M12 X 1.75 STV	

Model 2810 Hillco Leveling System
For Serial Numbers 2810-1301 thru 2810-1399
HYDRAULIC MANIFOLD

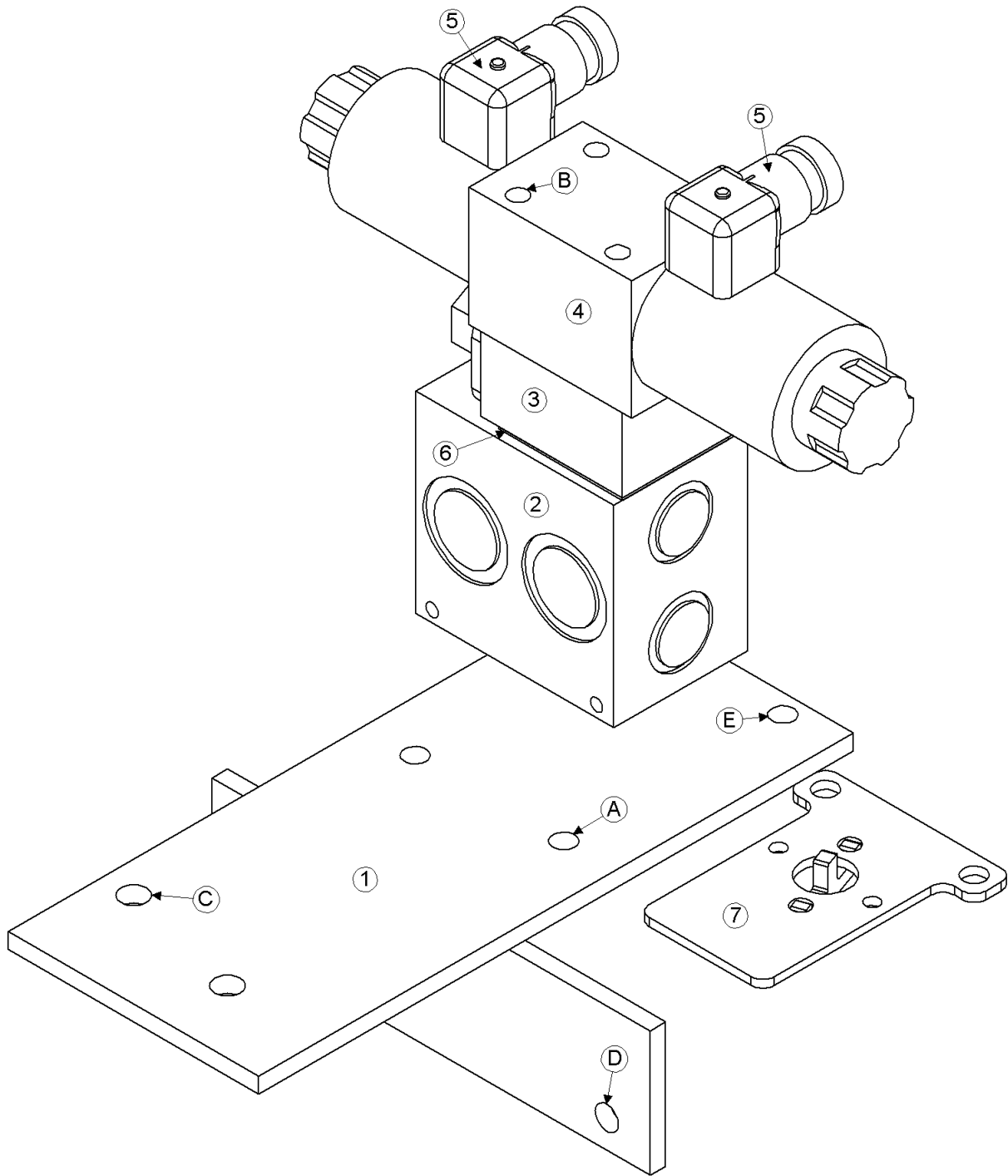

Model 2810 Hillco Leveling System
For Serial Numbers 2810-1301 thru 2810-1399

MANIFOLD COMPONENTS				
REF.	PART NO.	QTY.	PART NAME	DESCRIPTION
1	LA-251611	1	HM PLATE, MANIFOLD MOUNT	
2	HC-138861	1	MANIFOLD, SINGLE STATION	
3	HC-101264	1	SHUTTLE ASM, LOAD SENSE	
..	HC-101021	1	CARTRIDGE, LOAD SENSE VALVE	
..	HC-101022	1	BODY, LOAD SENSE VALVE	
NS	HC-102082	1	SEAL KIT, LOAD SENSE SHUTTLE ASM	
4	HC-140411	1	VALVE, DIRECTIONAL CONTROL, PROPORTIONAL	
NS	LM-250092	1	ORIFICE, .1875, DIRECTIONAL CONTROL VALVE	
NS	HC-142731	1	SEAL KIT, DIRECTIONAL CONTROL VALVE	
5	HC-140291	2	PLUG, DIN, LIGHTED	
6	HC-142761	1	SUBPLATE	
7	LA-259951	1	EM ASM, TILT SENSOR MOUNT	
MANIFOLD FASTENERS				
REF.	PART NO.	QTY.	PART NAME	WHERE USED
A	F-HCF-08M020E	4	FLHC-10.9 M8 X 1.25 X 20	SECURES MANIFOLD TO MOUNTING PLATE
A	F-HNF-08ME	4	FLHN-10.9 M8 X 1.25	SECURES MANIFOLD TO MOUNTING PLATE
B	F-SHC-#10C52	4	SHCS 10-24 X 3-1/4	MANIFOLD ASM
B	F-LW-#10	4	LW #10	MANIFOLD ASM
C	F-HCF-10M025E	2	FLHC-10.9 M10 X 1.50 X 25	MANIFOLD ASM TO COMBINE
C	F-HNF-10ME	2	FLHN-10.9 M10 X 1.50	MANIFOLD ASM TO COMBINE
D	F-HCF-08M025E	2	FLHC-10.9 M8 X 1.25 X 25	MANIFOLD ASM TO COMBINE
D	F-HNF-08ME	2	FLHN-10.9 M8 X 1.25	MANIFOLD ASM TO COMBINE
E	F-PHM-4M030F	2	PHMS M4 X 0.7 X 30	LATERAL TILT SENSOR TO MOUNT
E	F-HNF-4MF	2	FLHN-8.8 M4 X 0.7	LATERAL TILT SENSOR TO MOUNT

Model 2810 Hillco Leveling System
For Serial Numbers 2810-1301 thru 2810-1399

HYDRAULIC HOSES

LEVELING AND TRIM				
REF.	PART NO.	QTY.	PART NAME	WHERE USED
NS	LA-140521	2	1/4" 100R2 HOSE 14" #6 FORS 90 X #6 FORS	INNER MAIN ROD TO COUNTERBALANCE VALVE PORT #3 (LEFT & RIGHT)
NS	LA-140531	1	1/2" 100R2 HOSE 104" #8 FORS 90 X #8 FORS STR	LEVELING PORT "A" TO COUNTERBALANCE VALVE PORT #2 RIGHT
NS	LA-140541	1	1/2" 100R2 HOSE 184-1/2" #8 FORS 90 X #8 FORS STR	LEVELING PORT "B" TO COUNTERBALANCE VALVE PORT #2 RIGHT
NS	LA-133631	2	1/2" 100R2 HOSE 82" #8 FORS X #8 FORS	OUTER MAIN ROD TO COUNTERBALANCE VALVE PORT #2 (LEFT & RIGHT)
NS	LA-140561	1	1/4" 100R2 HOSE 116" #6 FORS X #6 FORS	MASTER CYLINDER BASE TO SLAVE CYLINDER BASE
NS	LA-140571	1	1/4" 100R2 HOSE 138" #6 FORS X #6 FORS	MASTER CYLINDER ROD TO SLAVE CYLINDER ROD
NS	LA-140581	1	1/4" 100R2 HOSE 111" #6 FORS X #6 FORS	FIELD TRACKER "HEAD" PORT TO MASTER BASE
NS	LA-140591	1	1/4" 100R2 HOSE 104" #6 FORS X #6 FORS	FIELD TRACKER "ROD" PORT TO MASTER ROD
NS	HC-133541	2	ABRASION SLEEVE, NYLON -- 2.19" ID X 32"	HOSES TO TRIM VALVE AND SLAVE CYL
NS	LA-140491	1	1/4" 100R2 HOSE 35-1/2" #6 FORS X #4 FORS	LOAD SENSE LINE
NS	LA-140501	1	5/8" 100R2 HOSE 28" #10 FORS X #10 FORS	LEVELING VALVE PRESSURE HOSE
NS	LA-140511	1	5/8" 100R1 HOSE 26" #10 FORS X #10 FORS	LEVELING VALVE RETURN HOSE
GREASE				
NS	LA-140662	1	3/16 R1 GREASE HOSE 47" 1/8 MPT X 1/8 MPT	MAIN PIVOT PIN TO LH BULKHEAD BTM
NS	LA-141911	1	3/16 R1 GREASE HOSE 25" 1/8 MPT X 1/8 MPT	MASTER BASE TO RH BULKHEAD TOP
NS	LA-141921	1	3/16 R1 GREASE HOSE 70" 1/8 MPT X 1/8 MPT	MASTER ROD TO RH BULKHEAD BTM
BRAKE HOSES				
NS	LA-140602	2	1/4" TITEFLEX HOSE 83" #3 MINV X #3 MINV WITH M10-1.0 X #3 FINV ADAPTER ON EACH END	LEFT & RIGHT BRAKE HOSES
HYDRO HOSES				
NS	LA-140551	2	1-1/4" 6000 PSI WP 82" W/ CODE 62 FLANGE STR. X CODE 62 FLANGE 90°	HYDROSTATIC HOSE EXTENSIONS

Model 2810 Hillco Leveling System
For Serial Numbers 2810-1301 thru 2810-1399

HYDRAULIC ADAPTERS

LEVELING MANIFOLD				
REF.	PART NO.	QTY.	PART NAME	WHERE USED
NS	HA-M-6MF6FF	1	#6 ORS SWIVEL NUT RUN TEE	LOAD SENSE LINE ON COMBINE
NS	HA-M-16FF16MF	2	#16 ORS SWIVEL NUT RUN TEE	PRESSURE AND TANK LINES ON COMBINE
NS	HA-S-16FF10MF	2	#16 FORS X # 10 MORS REDUCER W/ NUT	PRESSURE AND TANK LINES ON COMBINE
NS	HA-A-10MO	1	#10 MORB ALLEN HEAD PLUG	"T" PORT
NS	HA-L-10MF10MO	1	#10 MORS X #10 MORB 90°	"T" PORT
NS	HA-S-10MF10MO	1	#10 MORS X #10 MORB STR	"P" PORT
NS	HA-L-10FF10MF	1	#10 FORS X #10 MORS 90°	"P" PORT
NS	HA-L-8MF8MO	1	#8 MORS X #8 MORB 90°	"A" LEVELING PORT
NS	HA-L-8FF8MF	1	#8 MORS X #8 FORS 90°	"B" LEVELING PORT
NS	HA-S-8MF8MO	1	#8 MORS X #8 MORB STR	"B" LEVELING PORT
NS	HA-S-4MF4MO	1	#4 MORS X #4 MORB STR	LOAD SENSE SHUTTLE
CASE FIELD TRACKER VALVE				
NS	HA-L-6FF6MF	2	#6 FORS X # 6 MORS 90 DEG	FIELD TRACKER VALVE
MAIN CYLINDER AND COUNTERBALANCE VALVE				
NS	HA-L-8MO8MO	2	#8 MORB X #8 MORB 90°	LEFT & RIGHT COUNTERBALANCE VALVE PORT #1 TO MAIN CYL BASE
NS	HA-L-8MF8MO	2	#8 MORS X #8 MORB 90°	LEFT & RIGHT OUTER MAIN CYLINDER ROD
NS	HA-L-6MF8MO	2	#6 MORS X #8 MORB 90°	LEFT & RIGHT INNER MAIN CYLINDER ROD
NS	HA-T-8MF8MO	2	#8 MORS X #8 MORB STRTHREAD RUN TEE	LEFT & RIGHT COUNTERBALANCE VALVE PORT #2
NS	HA-L-6MF6MO	2	#6 MORS X # 6 MORB 90°	LEFT & RIGHT COUNTERBALANCE VALVE PORT #3
NS	HC-141931	2	ZERK, GREASE 1/4-28 45°	BASE END OF MAIN LEVELING CYLINDERS
MASTER AND SLAVE CYLINDERS				
NS	HA-Q-6MF6MO	2	#6MORS X #6MORB STR THREAD BRANCH TEE	MASTER BASE AND ROD PORTS
NS	HA-L-6MF6MO	1	#6 MORS X #6 MORB 90°	SLAVE ROD PORT
NS	HA-F-6MF6MO	1	#6 MORS X #6 MORB 45°	SLAVE BASE PORT
NS	HC-135771	1	1/4-28 MALE X 1/8 FPT 90°	BASE END OF MASTER CYLINDER
NS	HC-135881	1	1/4-28 MALE X 1/8 FPT STR	ROD END OF MASTER CYLINDER
GREASE				
NS	HA-S-2FP2MN	3	1/8" NPSM X 1/8" FPT BULKHEAD CONNECTOR	GREASE BULKHEAD MOUNT
NS	HA-NJ-2FN	3	1/8 NPSM BULKHEAD LOCKNUT	BULKHEAD CONNECTORS
NS	HA-L-2FP2MP	1	1/8 MPT 90 STREET EL	MAIN PIVOT PIN
NS	HC-138011	1	ZERK, GREASE 1/4-28 STR	MAIN PIVOT PIN
NS	HC-141231	1	ZERK, GREASE 1/8 MPT, 45°	DROP AXLE PIVOT PIN

Model 2810 Hillco Leveling System
 For Serial Numbers 2810-1301 thru 2810-1399

8 MISCELLANEOUS

DOCUMENTS AND LABELS				
REF.	PART NO.	QTY.	PART NAME	DESCRIPTION
NS	LA-141951	2	DECAL, CASE HILLSIDE LEVELING SYSTEM	SIDE PANELS ON COMBINE
NS	LL20-100782	1	CAUTION LEVELING SYSTEM CAB	WINDOW IN CAB
NS	LL20-100783	6	DANGER, CRUSHING HAZARD	FRONT & REAR OF UC LEFT & RIGHT
NS	LL20-100783	2	DANGER CRUSHING HAZARD	SIDE OF COMBINE ABOVE REAR TIRES
NS	LL20-100784	2	DANGER PINCH POINT	RH & LH UPPER TRANS FACE PLT
NS	LL20-100785	1	CAUTION MOVING STEP	COMBINE LADDER CHANNEL
NS	LL20-100786	1	WARNING, ELECTRONIC CRUSHING HAZARD	FRONT OF CONTROL BOX
NS	LL20-100787	2	CAUTION LEVELING SYSTEM HAZARD	CLEAN GRAIN ELEVATOR (RH); SCREEN (LH)
NS	LL20-100788	3	DANGER HYDRAULIC HAZARD	1- EA MAIN CYLINDER
NS	LL20-100788	1	DANGER HYDRAULIC HAZARD	ABOVE HYDRAULIC MANIFOLD
NS	LL-133741	2	LABEL, GREASE 50 HRS	RH AND LH MAIN LEV CYL BOTTOM
NS	LL-133741	1	LABEL, GREASE 50 HRS	BY BASE END OF SLAVE CYLINDER
NS	LL-133741	2	LABEL, GREASE 50 HRS	REAR FACE 12" ON BOTH SIDES OF PIVOT PIN
NS	LL-133741	2	LABEL, GREASE 50 HRS	RH AND LH BULKHEAD MOUNT
NS	LL-141011	2	DECAL, ROCK TRAP WARNING	BY ROCK TRAP HANDLE AND ON SHIELD ABOVE HANDLE
NS	LA-255951	1	PLATE, SERIAL NUMBER	LEFT REAR OF UNDERCARRIAGE
NS	D-060605ADL01A	1	MANUAL, PARTS	

9 PART NUMBER INDEX

PART NUMBER	PAGE NUMBER	PART NUMBER	PAGE NUMBER	PART NUMBER	PAGE NUMBER
D-090801ADL01A	8-1	F-HC-20M070E	3-4	F-LWH-08	2-6
EC-100008	6-4	F-HC-20M090E	3-4	F-MB-14NR40	2-4
EC-100557	6-2	F-HC-20M120	3-4	F-PCL-08X32	2-6
EC-100692	6-2	F-HC-20M280E	3-4	F-PCL-16X32	2-4
EC-136211	6-2	F-HC-22M150E	2-4	F-PCT-02X16	2-6
EC-136221	6-2	F-HC5-04C12	6-2	F-PCT-03X32	2-4
EC-138781	6-2	F-HC-6M090F	3-4	F-PHM-#10C16	6-2
EC-138791	6-2	F-HC8-08F20	2-6	F-PHM-#6C06	6-2
EC-138801	6-2	F-HC-8M025F	2-4	F-PHM-#6C12	6-2
EC-139641	6-4	F-HC-8M040F	3-4	F-PHM-04C24	6-2
EC-140751	6-2	F-HCF-08M020E	3-4, 6-2, 7-4	F-PHM-04C36	6-2
EC-140761	6-2	F-HCF-08M025E	7-4	F-PHM-4M030F	6-2, 7-4
EC-140771	6-2	F-HCF-10M016F	2-4	F-PHM-5M050F	6-2
EC-140871	6-2	F-HCF-10M020E	2-4, 3-4, 5-2	F-PHM-6M020F	6-2
EC-140891	6-4	F-HCF-10M025E	2-4, 7-4	F-PHM-6M015F	6-2
EC-141741	6-4	F-HCF-12M025F	3-4	F-PQR-08X32	2-4
EC-141751	6-4	F-HCF-12M030E	3-4	F-PR-06X40	2-6
EC-141761	6-4	F-HCF-12M040E	2-4	F-SHC-#10C52	7-4
EC-141771	6-4	F-HCF-12M080E	2-4	F-SHC-20M090E	3-4
EC-141781	6-4	F-HCF-8M020E	5-2	F-SSS-04F04	7-2
EC-141791	6-4	F-HN-#10C	6-2	F-SSS-06C08	2-6
EC-141801	6-4	F-HN5-12C	5-2	F-UDS-#7X06	3-4
EC-141811	6-4	F-HNF-#10C	6-2	HA-A-10MO	7-6
EC-141821	6-4	F-HNF-#6C	6-2	HA-F-6MF6MO	7-6
EC-141831	6-2	F-HNF-04C	6-2	HA-L-10FF10MF	7-6
EC-141891	6-2	F-HNF-06MF	2-4	HA-L-10MF10MO	7-6
EC-141901	6-2	F-HNF-06ME	2-6	HA-L-2FP2MP	7-6
EC-142101	3-2	F-HNF-08ME	3-4, 6-4, 7-4	HA-L-6FF6MF	7-6
EC-142121	6-2	F-HNF-08MF	2-4, 3-4, 5-2	HA-L-6MF6MO	7-6
ET-SP-20	6-4	F-HNF-10ME	2-4, 5-2, 7-4	HA-L-6MF8MO	7-6
ET-ST-20#10	6-4	F-HNF-10MF	2-4	HA-L-8FF8MF	7-6
ET-ST-2005	6-4	F-HNF-12C	2-4	HA-L-8MF8MO	7-6
F-CB-10M030F	2-4	F-HNF-12ME	2-4, 5-2	HA-L-8MO8MO	7-6
F-CB-12C56	2-4	F-HNF-12MF	3-4	HA-M-16FF16MF	7-6
F-EYB-20M150E	2-4	F-HNF-20ME	2-4	HA-M-6MF6FF	7-6
F-FHS-8M016E	2-4	F-HNF-4MF	7-4	HA-NJ-2FN	7-6
F-FW-04	6-2	F-HNF-5MF	6-2	HA-Q-6MF6MO	7-6
F-FWH-08	2-4	F-HNF-6MF	3-4	HA-S-10MF10MO	7-6
F-FWH-10	2-4	F-HNF-8MF	2-4, 3-4	HA-S-16FF10MF	7-6
F-HC-06M020F	2-4	F-HNJ-05C	5-2	HA-S-2FP2MN	7-6
F-HC-06M020F	2-6, 3-4	F-HNJ-12MF	2-4	HA-S-4MF4MO	7-6
F-HC-08M025F	5-2	F-HNS-10ME	5-2	HA-T-8MF8MO	7-6
F-HC-10M040F	5-2	F-HNS-12ME	3-4	HC-100706	2-2, 7-2
F-HC-12M030F	5-2	F-HNS-12ME	7-2	HC-101021	7-4
F-HC-12M040E	3-4	F-HNS-16ME	2-4, 3-4	HC-101022	7-4
F-HC-12M050F	5-2	F-HNS-20ME	3-2	HC-101264	7-4
F-HC-12M065F	5-2	F-HNSF-12ME	2-4	HC-101842	3-2, 7-2
F-HC-12M070E	7-2	F-LW-#10	7-4	HC-102082	7-4
F-HC-12M280F	5-2	F-LW-04	6-2	HC-102218	3-2, 7-2
F-HC-16M050E	2-4, 3-4	F-LW-05	5-2	HC-133541	7-5
F-HC-16M110E	2-4	F-LW-12	5-2	HC-134191	7-2
F-HC-16M120E	2-4	F-LWE-05	6-2	HC-134201	7-2

Model 2810 Hillco Leveling System
For Serial Numbers 2810-1301 thru 2810-1399
PART NUMBER INDEX (CONTINUED)

PART NUMBER	PAGE NUMBER	PART NUMBER	PAGE NUMBER	PART NUMBER	PAGE NUMBER
HC-134221	7-2	LA-251531	3-2	LM-251871	3-2
HC-135771	7-6	LA-251611	7-4	LM-251881	2-2
HC-135881	7-6	LA-251623	2-2	LM-252611X	6-2
HC-138011	7-6	LA-251632	2-2	LM-252621	6-2
HC-138861	7-4	LA-251801	5-2	LM-253862	2-2
HC-139151	3-2, 7-2	LA-251802	5-2	LM-255121	2-2
HC-139161	7-2	LA-251831	3-2	LM-255181	2-2
HC-139181	7-2	LA-252161	4-2	LM-255191	2-2
HC-139451	3-2	LA-253621	2-2	LM-255201	2-2
HC-139461	3-4	LA-254452	6-2	LM-255301	3-2
HC-140291	7-4	LA-254472	6-2	LM-255331	6-2
HC-140361	7-2	LA-254951	7-2	LM-255341	6-2
HC-140411	7-4	LA-255141	2-2	LM-259861	2-2
HC-140431	7-2	LA-255161	2-2	LM-262031	2-2
HC-140441	7-2	LA-255171	2-2	LM-262811X	2-2
HC-140451	7-2	LA-255631	6-4	LM-262951	2-2
HC-140461	3-2	LA-255751	6-4	LM-263091	2-2
HC-140641	3-2	LA-255821	6-2, 6-4	LP-249321	3-2
HC-140651	3-2	LA-255951	3-2, 8-1	LP-249871	2-2
HC-141231	7-6	LA-259661	6-2	LP-251071	3-2
HC-141931	7-6	LA-259671	6-2	LP-251432	6-2
HC-142731	7-4	LA-259821	2-2, 2-6	LP-251461	3-2
HC-142761	7-4	LA-259881	2-2	LP-251551	3-2
HC-143601	8-1	LA-259951	7-4	LP-251783	2-2
LA-133631	7-5	LA-262981	2-2	LP-253851	2-2
LA-140491	7-5	LA-263061	2-2	LP-262041	2-2
LA-140501	7-5	LA-263071	2-2	LP-263211	4-2
LA-140511	7-5	LA-265481	6-4	LP-263221	4-2
LA-140521	7-5	LL-133741	8-1	LS-212701	2-2
LA-140531	7-5	LL-141011	8-1	LTP-241721	2-2
LA-140541	7-5	LL20-100782	8-1	MC-100237	2-2
LA-140551	7-5	LL20-100783	8-1	MC-100548	2-2
LA-140561	7-5	LL20-100784	8-1	MC-101339	2-2
LA-140571	7-5	LL20-100785	8-1	MC-101838	2-2
LA-140581	7-5	LL20-100786	8-1	MC-135491	2-2
LA-140591	7-5	LL20-100787	8-1	MC-135511	2-2
LA-140602	7-5	LL20-100788	8-1	MC-136151	2-2
LA-140662	7-5	LM-212701	2-2	MC-137251	3-2
LA-141911	7-5	LM-213243	2-2	MC-137501	3-2
LA-141921	7-5	LM-219801	2-2	MC-138641	3-2
LA-141951	8-1	LM-226532	2-2, 2-6	MC-138651	3-2
LA-229071	2-2, 3-2	LM-226841	2-2	MC-139361	2-2
LA-230551	3-2	LM-263201	6-2	MC-139371	2-2
LA-243691	2-2	LM-241122X	6-2	MC-140791	4-2
LA-247481	3-2	LM-244471	2-2, 2-6	MC-141961	3-4
LA-249062	6-4	LM-250092	7-4	MC-141971	3-4
LA-249102	6-4	LM-250641	2-2	MC-141981	3-4
LA-251322	2-2	LM-251002	2-2	MC-142871	2-2
LA-251471	3-2	LM-251641	6-2	MC-142881	2-2
LA-251481	3-2	LM-251771	2-2	MC-143121	2-6
LA-251491	3-2	LM-251791	2-2	MC-143921	2-6
LA-251512	2-2	LM-251861	3-2		