

**Model 2800**  
**Hillside Leveling System**  
**Parts Manual**

SN 2800-1157 thru 2800-1180  
D-060609ADL01A







**2800 Leveling System**  
*for 2188, 2377 and 2388 CASE-IH Combines*

**TABLE OF CONTENTS**

<b>1 GENERAL INFORMATION</b> .....	<b>1-3</b>
Serial Number Location .....	1-3
Text Format and Illustrations .....	1-3
Abbreviations.....	1-3
Right and Left Identification .....	1-3
Parts Orders .....	1-3
<b>2 TRANSITION</b> .....	<b>2-1</b>
Radial Pin Slip Clutch and Header Lift Cylinder Extensions .....	2-3
Transition Fasteners.....	2-5
<b>3 CARRIAGE</b> .....	<b>3-1</b>
Carriage Fasteners.....	3-3
<b>4 Y-BRACE</b> .....	<b>4-1</b>
<b>5 DROP AXLE</b> .....	<b>5-1</b>
<b>6 LADDER</b> .....	<b>6-1</b>
<b>7 ELECTRICAL</b> .....	<b>7-1</b>
Electrical Connectors .....	7-3
Electrical Cables.....	7-5
<b>8 HYDRAULICS</b> .....	<b>8-1</b>
Hydraulic Manifold.....	8-3
Hydraulic Hoses .....	8-5
Hydraulic Hoses (Continued).....	8-6
Hydraulic Adapters .....	8-7
Hydraulic Adapters (Continued) .....	8-8
<b>9 MISCELLANEOUS</b> .....	<b>9-1</b>
<b>10 PART NUMBER INDEX</b> .....	<b>10-1</b>
Part Number Index (Continued).....	10-2

Model 2800 Hillco Leveling System  
For Serial Numbers 2800-1157 thru 2800-1180

Hillco Technologies, Inc.  
107 1<sup>st</sup> Avenue  
Nezperce Id. 83543

Fax	208.937.2280
Phone	208.937.2461
Toll Free	800.937.2461

[www.hillcotechnologies.com](http://www.hillcotechnologies.com)

## 1 GENERAL INFORMATION

### SERIAL NUMBER LOCATION

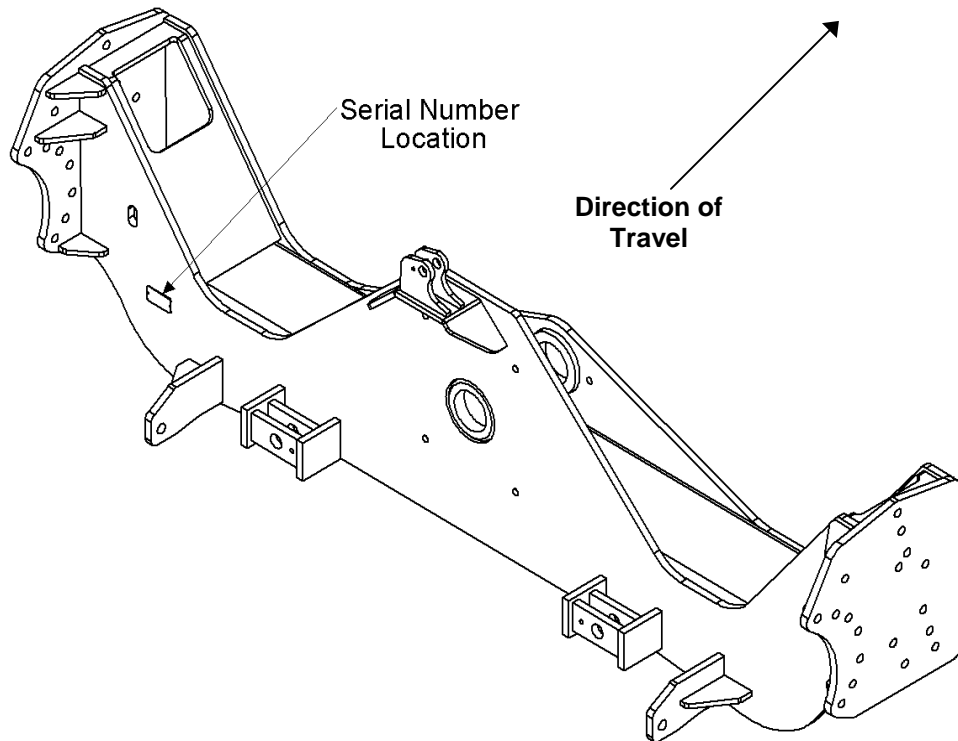

### TEXT FORMAT AND ILLUSTRATIONS

The arrangement of this parts catalog is for easy identification of parts. All parts are illustrated in exploded views in proper relation to each other. Some diagrams refer to other pages for further information. Reference numbers used in the illustrations refer to line numbers in the part lists. The part lists appear to the right of all diagrams and correspond with those diagrams. Included in the part lists, along with the reference numbers are part numbers, part descriptions, and the quantity of the part required per leveling system.

### ABBREVIATIONS

**SN** "Serial Number" The four digits shown in the SN column refer to the last four digits in the Hillco serial number. Each Model 2800 system uses the following format:  
2800-XXXX (sequential numbers).

**ASM** "Assembly" refers to a whole grouping of parts (usually shown in the diagram to corresponding with the page where "ASM" is shown).

**NS** "Not Shown" refers to a part that is not depicted in the illustration.

### RIGHT AND LEFT IDENTIFICATION

The reference to right-hand and left-hand in this catalog is identified by the operator standing at the rear of the machine looking toward the front of the machine (in normal forward travel).

### PARTS ORDERS

Orders must specify product model, serial number, correct part number, complete description, quantity required, method of shipment, shipping address, and billing address.

## 2 TRANSITION

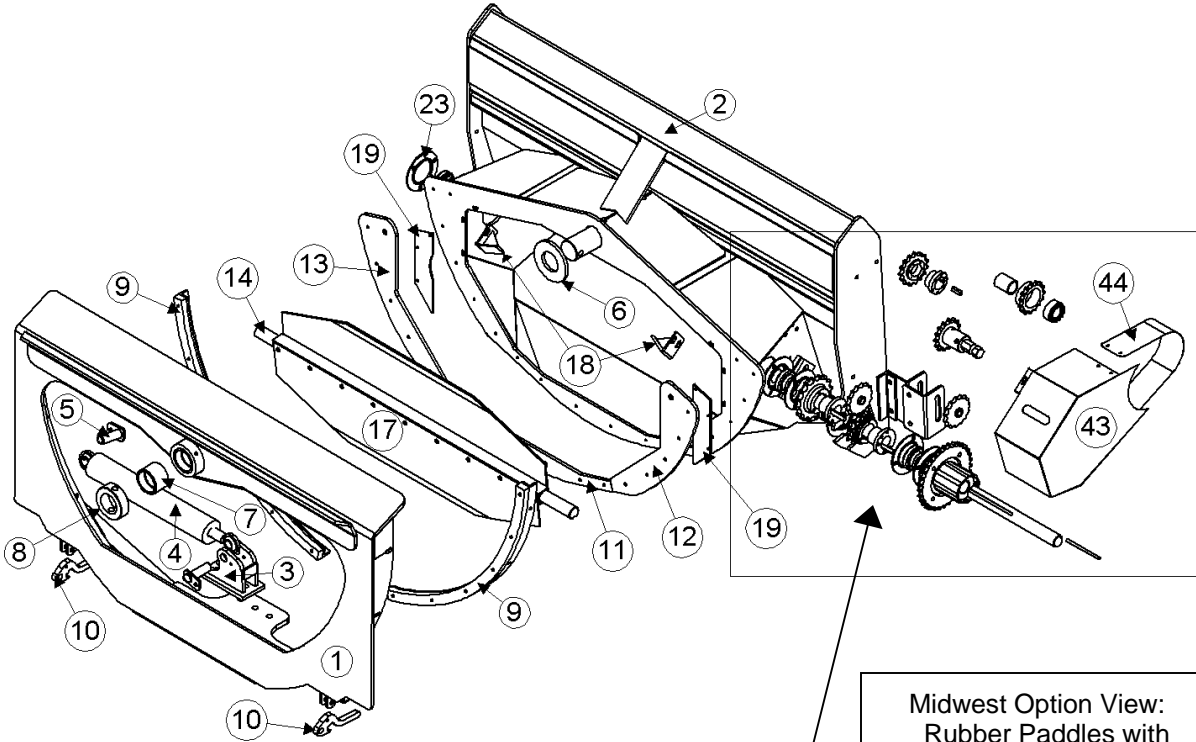

SEE PAGE 2-5 FOR  
TRANSITION FASTENERS

Midwest Option View:  
Rubber Paddles with  
Backing Plates

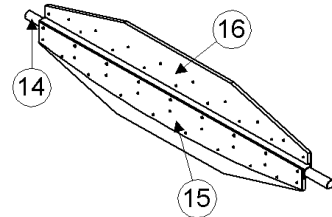

## TRANSITION DRIVE COMPONENT DETAIL

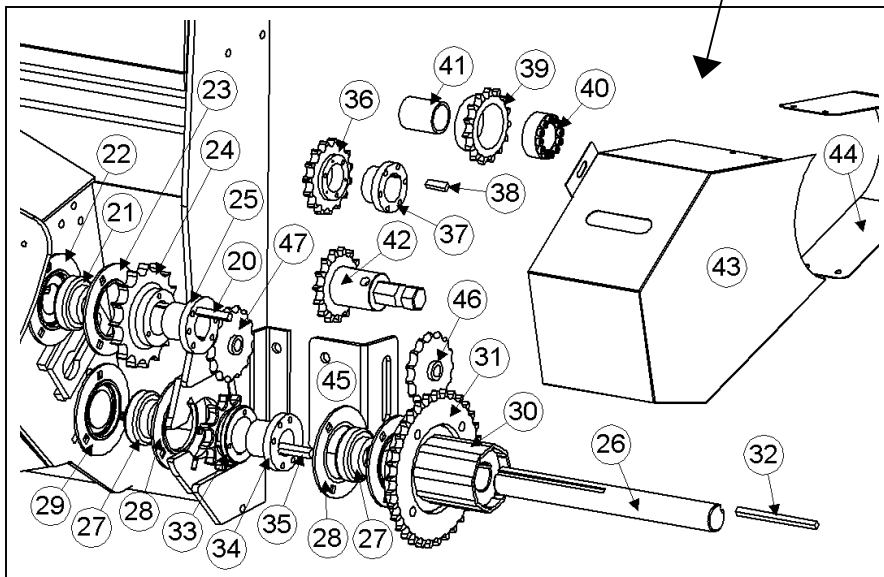

Model 2800 Hillco Leveling System  
For Serial Numbers 2800-1157 thru 2800-1180

<b>TRANSITION</b>				
<b>REF.</b>	<b>PART NO.</b>	<b>QTY.</b>	<b>PART NAME</b>	<b>DESCRIPTION</b>
1	LA-227101	1	TA ADAPTER ASM	
2	LA-226852	1	TT THROAT ASM	
3	LA-225411	1	TM MOUNT ASM, ROD	
4	HC-100706	1	CYLINDER, SLAVE	SEE HYDRAULIC PAGE 8-2
NS	HC-134191	1	SEAL KIT, SLAVE CYLINDER	
5	LA-229071	2	TM PIN ASM, TRIM CYLINDER	
6	LP-218371	1	TM RING, WEAR	
7	LM-226831	1	TM BUSHING, PIVOT	
8	LM-226841	1	TM COLLAR, PIVOT	
9	LA-243711	2	ANGLE, BACKING ASM 26-2800	
..	LM-225311	1	TM, ANGLE BACKING	NOT SOLD SEPARATELY
..	LS-225321	1	TM PAD, BACKING ANGLE WEAR	NOT SOLD SEPARATELY
..	F-FHS-05F20	8	FHSC 5/16-24 X 1-1/4	NOT SOLD SEPARATELY
..	F-HNS-05F	8	HN 5/16-24 STOVER	NOT SOLD SEPARATELY
10	LM-213291	2	TM ARM, HEADER LOCK	
11	LM-225522	1	TM PLATE, WEAR BOTTOM	
12	LM-225531	1	TM PLATE, WEAR LH	
13	LM-225541	1	TM PLATE, WEAR RH	
<b>BEATER SHAFT</b>				
14	LM-221602	1	TB SHAFT	
15	LM-213202	2	TB PLATE, PADDLE BACKING	MIDWEST COMBINES ONLY
16	LP-104791	2	TB PADDLE, RUBBER	MIDWEST COMBINES ONLY
17	LM-238091	2	TB PADDLE, METAL	NORTHWEST COMBINES ONLY
18	LA-259781	2	TM ASM, ANTI-WRAP	NORTHWEST COMBINES ONLY - OPTIONAL
19	LM-254521	2	TM PLT, NARROWING	NORTHWEST COMBINES ONLY - OPTIONAL
20	LS-212701	1	TM KEY, BEATER DRIVE	
21	MC-100548	2	INSERT, BEARING, 1-7/16	
22	LA-243691	2	TM ASM, INNER FLANGETTE	
23	MC-101339	1	FLANGETTES, RND BEARING (PAIR)	
24	MC-135501	1	SPROCKET, 80P, 16T TAPER BORE	
25	MC-135511	1	HUB, SPLIT TAPER 1-7/16	
NS	LP-213242	1	TM CHAIN, 30 PIN #80	
NS	MC-139341	1	LINK, CONNECTING, 80P	
NS	MC-139351	1	LINK, OFFSET, 80P	
<b>TRANSITION THROAT JACK SHAFT</b>				
26	LM-234152	1	TT SHAFT, JACK	
27	MC-100548	2	INSERT, BEARING, 1-7/16	
28	MC-101339	1.5	FLANGETTES, RND BEARING (PAIR)	
29	LA-245191	1	TM ASM, JS INNER FLANGETTE	
30	MC-136921	1	RADIAL PIN SLIP CLUTCH	SEE PAGE 2-3 FOR DETAIL
31	LM-226532	1	TM SPROCKET, RADIAL SLIP CLUTCH	
32	LS-244471	1	TM KEY, RADIAL SLIP CLUTCH	
33	MC-135491	1	SPROCKET, 80P, 11T TAPER BORE	
34	MC-135511	1	HUB, SPLIT TAPER 1-7/16	
35	LS-212701	1	TM KEY, BEATER DRIVE	
NS	LP-213252	1	TM CHAIN, 62 PIN #60	
NS	MC-139361	1	LINK, CONNECTING, 60P	
NS	MC-139371	1	LINK, OFFSET, 60P	
<b>FEEDER HOUSE BEATER DRIVE</b>				
36	MC-100760	1	SPROCKET, QD, 60P, 15T	BEFORE SN JJCO193725
37	MC-100762	1	HUB, QD, 1-1/2B	BEFORE SN JJCO193725
38	LS-234221	1	TM KEY, FEEDER SHAFT	BEFORE SN JJCO193725
39	MC-101839	1	SPROCKET, POWER LOCK, 60P, 15T	SN JJCO193725 THRU JJCO268799
40	MC-101838	1	HUB, POWER LOCK, 1-3/8B	SN JJCO193725 THRU JJCO268799
41	LS-207011	1	TM SPACER, DRIVE SPROCKET	BEFORE SN JJCO268800
42	LA-234251	1	TM DRIVE ASM, TRANSITION	SN JJCO268800 AND AFTER
43	LM-243821	1	TM SHIELD, BEATER DRIVE	SN JJCO117059 AND AFTER
NS	LM-243841	1	TM SKIRT, BEATER DRIVE SHIELD	BEFORE SN JJCO268800
44	LM-243831	1	TM SKIRT, BEATER DRIVE SHIELD	SN JJCO268800 AND AFTER
NS	LM-243801	1	TM BRACKET, 60P IDLER	BEFORE SN JJCO268800
45	LM-243792	1	TM BRACKET, 60P IDLER	SN JJCO268800 AND AFTER
<b>TENSIONER</b>				
46	MC-100237	1	SPROCKET, IDLER, 60P, 15T, 5/8B	SN JJCO193725 THRU CURRENT
47	MC-137441	1	SPROCKET, IDLER, 80P, 12T, 3/4B	

### **RADIAL PIN SLIP CLUTCH AND HEADER LIFT CYLINDER EXTENSIONS**

#### **RADIAL PIN SLIP CLUTCH DETAIL**

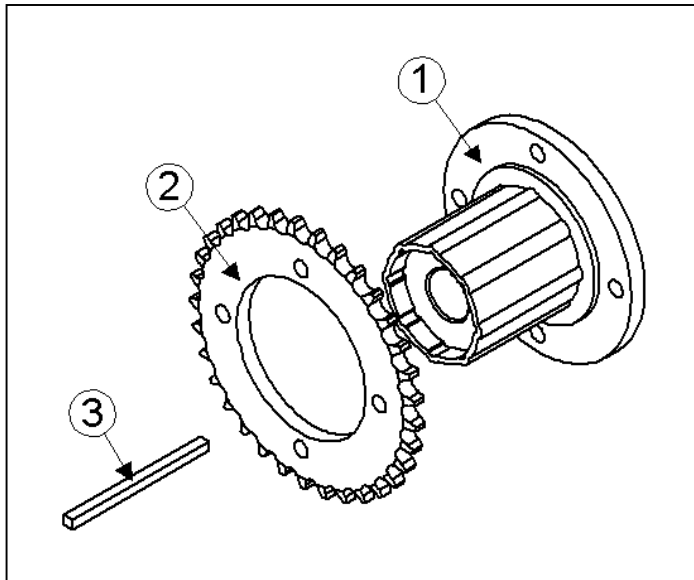

#### **HEADER LIFT CYLINDER EXTENSION DETAIL**

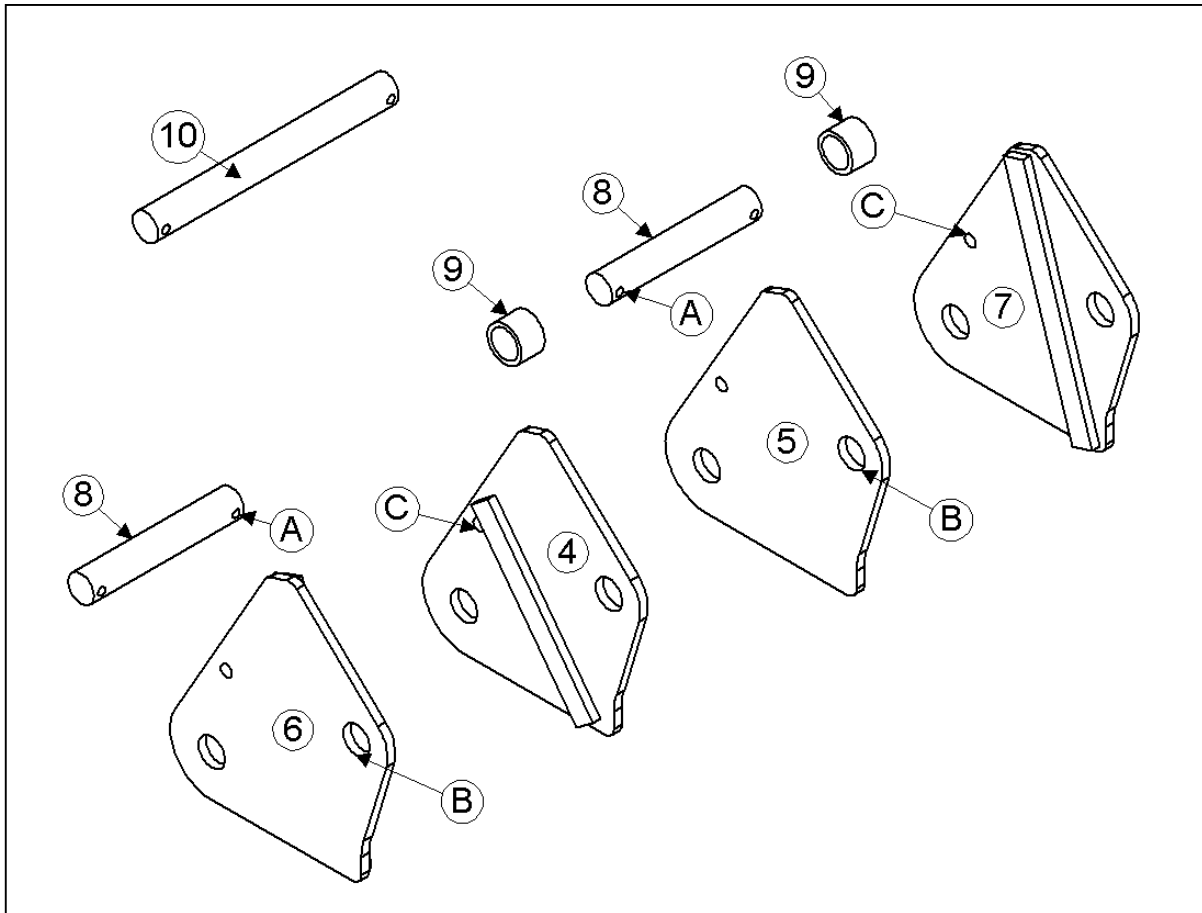



Model 2800 Hillco Leveling System  
For Serial Numbers 2800-1157 thru 2800-1180

<b>RADIAL PIN SLIP CLUTCH ASM</b>				
<b>REF.</b>	<b>PART NO.</b>	<b>QTY.</b>	<b>PART NAME</b>	<b>DESCRIPTION</b>
1	MC-136921	1	RADIAL PIN SLIP CLUTCH	
2	LM-226532	1	TM SPROCKET, RADIAL SLIP CLUTCH	
3	LS-244471	1	TM KEY, RADIAL PIN SLIP CLUTCH	
NS	F-HC8-08F20	4	HC8 1/2-20 X 1-1/4	
NS	F-LWH-08	4	LW 1/2 HD	
NS	F-SSS-06C08	2	SCREW, SOCKET SET 3/8-16 X 1/2	
<b>HEADER LIFT CYLINDER EXTENSIONS</b>				
<b>60 IN. FEEDER HOUSE (NEVER HAS ROCK TRAP)</b>				
4	LA-220631	↓	LM EXTENSION ASM, LIFT CYLINDER INNER LH	
4		1	WITH 2 HEADER LIFT CYLINDERS	
NS		2	WITH 3 HEADER LIFT CYLINDERS	
5	LA-220661	↓	LM EXTENSION ASM, LIFT CYLINDER INNER RH	
6	LA-220641	1	LM EXTENSION ASM, LIFT CYLINDER OUTER LH	
7	LA-220651	1	LM EXTENSION ASM, LIFT CYLINDER OUTER RH	
8	LM-218501	2	LM PIN, HEADER LIFT CYLINDER ROD MOUNT	
9	LS-226961	↓	LM SPACER, HEADER LIFT CYLINDER	
9		2	WITH 2 HEADER LIFT CYLINDERS	
NS		4	WITH 3 HEADER LIFT CYLINDERS	
<b>54 IN. FEEDER HOUSE WITHOUT ROCK TRAP</b>				
NS	LA-240111	2	LM ASM, LEFT LIFT CYL EXT	
NS	LA-240121	↓	LM ASM, RIGHT LIFT CYL EXT	
NS		2	WITH 2 HEADER LIFT CYLINDERS	
NS		3	WITH 3 HEADER LIFT CYLINDERS	
8	LM-218501	2	LM PIN, HEADER LIFT CYLINDER ROD MOUNT	
9	LS-226961	↓	LM SPACER, HEADER LIFT CYLINDER	
9		2	WITH 2 HEADER LIFT CYLINDERS	
NS		4	WITH 3 HEADER LIFT CYLINDERS	
<b>54 IN. FEEDER HOUSE WITHOUT ROCK TRAP AND 3RD HEADER LIFT CYLINDER</b>				
10	LM-235481	1	LM PIN, 3RD HEADER LIFT CYL ROD MNT	
<b>54.5 IN. &amp; 60 IN. FEEDER SPOUTS WITHOUT ROCK TRAP FASTENERS</b>				
A	F-PCT-05X48	4	COTTER PIN 5/16 X 3	
B	F-HC8-20C40	↓	HC8 1-1/4-7 X 2-1/2 ZINC PLT	
B		4	WITH 2 HEADER LIFT CYLINDERS	
NS		5	WITH 3 HEADER LIFT CYLINDERS	
B	F-HNS-20C	↓	HN8 1-1/4-7 STV	
B		4	WITH 2 HEADER LIFT CYLINDERS	
NS		5	WITH 3 HEADER LIFT CYLINDERS	
C	F-HC5-08C104	↓	HC5 1/2-13 X 6-1/2	
C		2	WITH 2 HEADER LIFT CYLINDERS	
NS		1	WITH 3 HEADER LIFT CYLINDERS	
C	F-HNS-08C	2	HN 1/2-13, STV	
NS	F-HC5-08C176	↓	HC5 1/2-13 X 11	
NS		1	WITH 3 HEADER LIFT CYLINDERS	
<b>COMBINES WITH ROCK TRAP</b>				
NS	LS-257951	2	LM SPACER, HEADER LIFT CYLINDER	SN JJCO117059 AND AFTER

**TRANSITION FASTENERS**

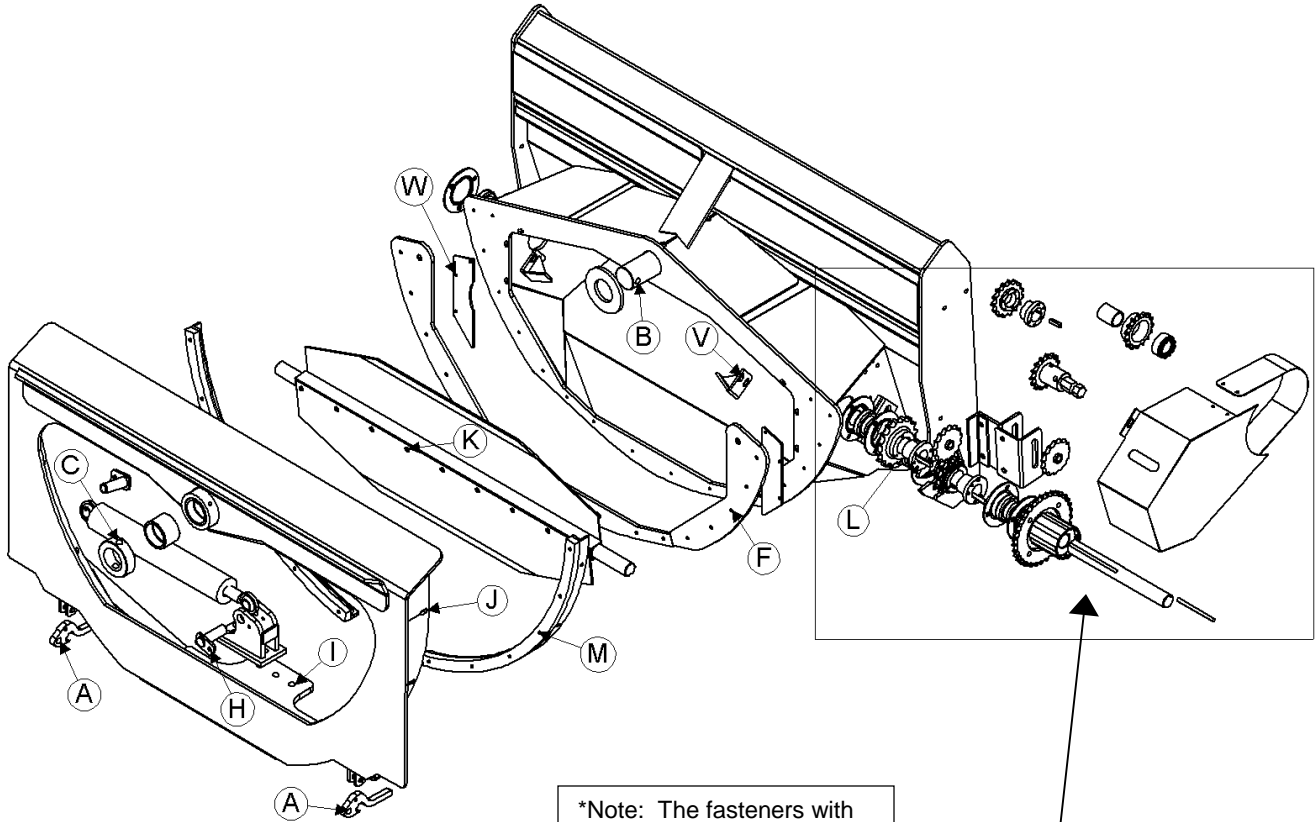

\*Note: The fasteners with reference number "L" attach to the bottom of the Transition for mounting purposes, however they cannot be seen in this view. The leader is pointing to the general area.

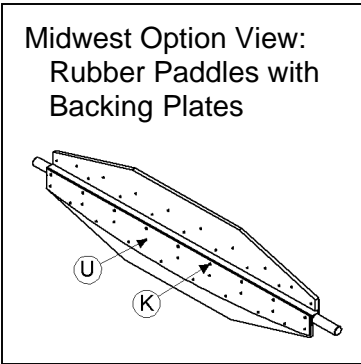

**Drive Component Fasteners Detail**

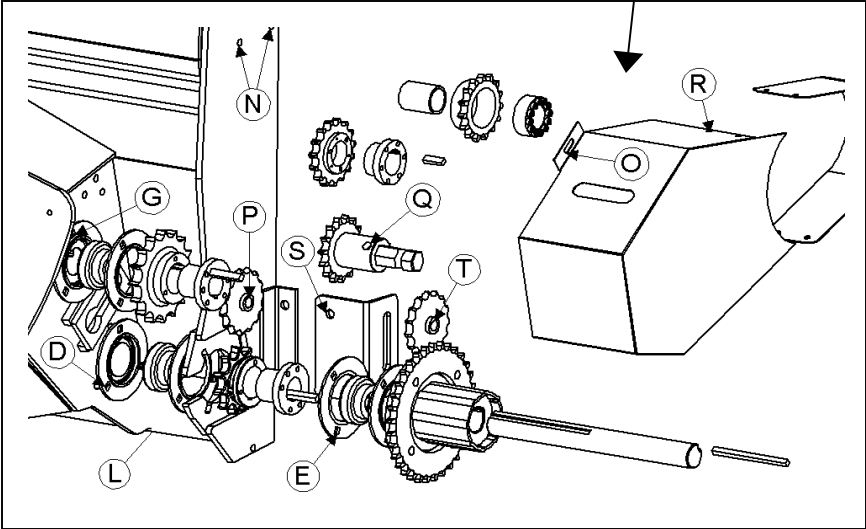

Model 2800 Hillco Leveling System  
For Serial Numbers 2800-1157 thru 2800-1180

<b>TRANSITION FASTENERS</b>				
<b>REF.</b>	<b>PART NO.</b>	<b>QTY.</b>	<b>PART NAME</b>	<b>WHERE USED</b>
A	F-PCL-10X24	2	PIN, CLEVIS, 5/8 X 1-1/2	HEADER LOCK ARM
A	F-PCT-02X16	2	PIN, COTTER, 1/8 X 1	HEADER LOCK ARM
B	F-MB-14NR40	3	BUSHING, MACH 14 GA, NR, 2-1/2 ID	TT PIVOT PIN
C	F-HC8-10C80	1	HC8 5/8-11 X 5	TT PIVOT PIN COLLAR
C	F-HNS-10C	1	HN8 5/8-11, STV	TT PIVOT PIN COLLAR
D	F-CB-06C20	3	BOLT, CARRIAGE, 3/8-16 X 1-1/4	INNER JACKSHAFT BEARING
D	F-HN5-06C	3	HN5 3/8-16	INNER JACKSHAFT BEARING
D	F-LW-06	3	LW 3/8	INNER JACKSHAFT BEARING
E	F-CB-06C20	3	BOLT, CARRIAGE, 3/8-16 X 1-1/4	OUTER JACKSHAFT BEARING
E	F-HN5-06C	3	HN5 3/8-16	OUTER JACKSHAFT BEARING
E	F-LW-06	3	LW 3/8	OUTER JACKSHAFT BEARING
F	F-FHS-05F10	18	FHSC 5/16-24 X 5/8	UHMW WEAR PADS TO FACE PLATE
G	F-LW-06	6	LW 3/8	TT BEATER BRNG
G	F-CB-06C20	6	BOLT, CARRIAGE, 3/8-16 X 1-1/4	TT BEATER BRNG
G	F-HN5-06C	6	HN5 3/8-16	TT BEATER BRNG
H	F-HC5-06C12	2	HC5 3/8-16 X 3/4	SLAVE CYL MNT PIN
H	F-LW-06	2	LW 3/8	SLAVE CYL MNT PIN
I	F-HC8-10C32	3	HC8 5/8-11 X 2	ROD MNT
I	F-HNS-10C	3	HN8 5/8-11 STV	ROD MNT
J	F-HC5-06C20	8	HC5 3/8-16 X 1-1/4	BACKING ANGLE
J	F-HNS-06C	8	HN5 3/8-16 STV	BACKING ANGLE
J	F-FWH-06	8	FW 3/8 HD	BACKING ANGLE
K	F-HC8-08C44	9	HC8 1/2 -13 X 2-3/4	BEATER BACKING PLT MNT OR STEEL PADDLES
K	F-HNSF-08C	9	HN8 1/2-13, STV	BEATER BACKING PLT MNT OR STEEL PADDLES
L	F-HC5-08C32	2	HC5 1/2-13 X 2	TRANSITION MNT
L	F-HN5-08C	2	HN5 1/2-13	TRANSITION MNT
L	F-LW-08	2	LW 1/2	TRANSITION MNT
M	F-FHS-05F20	16	FHSC 5/16-24 X 1-1/4	UHMW BACKING WEAR PAD
M	F-HNS-05F	16	HN 5/16-24, STV	UHMW BACKING WEAR PAD
N	F-THM-06C16	2	THMS 3/8-16 X 1	HEADER HYDRAULIC COUPLER MOUNT
N	F-HNF-06C	2	HN 3/8-16, SERR	HEADER HYDRAULIC COUPLER MOUNT
O	F-THMS-05C16	2	THMS 5/16-18 X 1, SLT SERR	BEATER DRIVE SHIELD
O	F-HNF-05C	2	HN 5/16-18, SERR	BEATER DRIVE SHIELD
P	F-HNN-12C	1	HN 3/4-10 NYLOCK	80P IDLER SPROCKET
P	F-FWH-12	5	FW 3/4 HD	80P IDLER SPROCKET
P	F-MB-12WR18	2	BUSHING, MACH 18 GA, WR, 3/4 ID	80P IDLER SPROCKET
<b>SN JJC0268800 &amp; AFTER (THESE ARE ALL COMBINES WITH HYDRAULIC HEADER REVERSER)</b>				
Q	F-SSS-06C08	2	SET SCREW, SOCKET 3/8-16 X 1/2, GRADE 8	USE #242 LOCTITE
<b>SN JJC0117059 &amp; AFTER</b>				
R	F-THMS-04C08	4	THMS 1/4-20 X 1/2, SLT SERR	BEATER DRIVE SHIELD
R	F-HNF-04C	4	HN 1/4-20, SERR	BEATER DRIVE SHIELD
S	F-HC5-08C20	2	HC5 1/2-13 X 1-1/4	60P IDLER SPROCKET BRACKET
S	F-LW-08	2	LW 1/2	60P IDLER SPROCKET BRACKET
S	F-HN5-08C	2	HN5 1/2-13	60P IDLER SPROCKET BRACKET
T	F-CB-10C40	1	BOLT, CARRIAGE GR 5 5/8-11 X 2-1/2	60P IDLER SPROCKET
T	F-HNN-10C	1	HN 5/8-11, NYLOCK	60P IDLER SPROCKET
T	F-FWH-10	10	FW 5/8 HD	60P IDLER SPROCKET
T	F-FWH-12	1	FW 3/4 HD	60P IDLER SPROCKET
<b>FOR MIDWEST COMBINES</b>				
U	F-EB-04C20	38	BOLT, ELEVATOR, 1/4-20 X 1-1/4	BEATER PADDLES
U	F-HNF-04C	38	FLHN 1/4-20, SERR	BEATER PADDLES
<b>FOR NORTHWEST COMBINES</b>				
V	F-HC8-06C16	4	HC8 3/8-16 X 1	ANTI-WRAP ASSEMBLIES
V	F-HNF-06C	4	FLHN 3/8-16, SERR	ANTI-WRAP ASSEMBLIES
W	F-HC5-04C20	6	HC5 1/4-20 X 1-1/4	THROAT NARROWING PLATES
W	F-HN5-04C	6	HN5 1/4-20	THROAT NARROWING PLATES
W	F-LW-04	6	LW 1/4	THROAT NARROWING PLATES

### 3 CARRIAGE

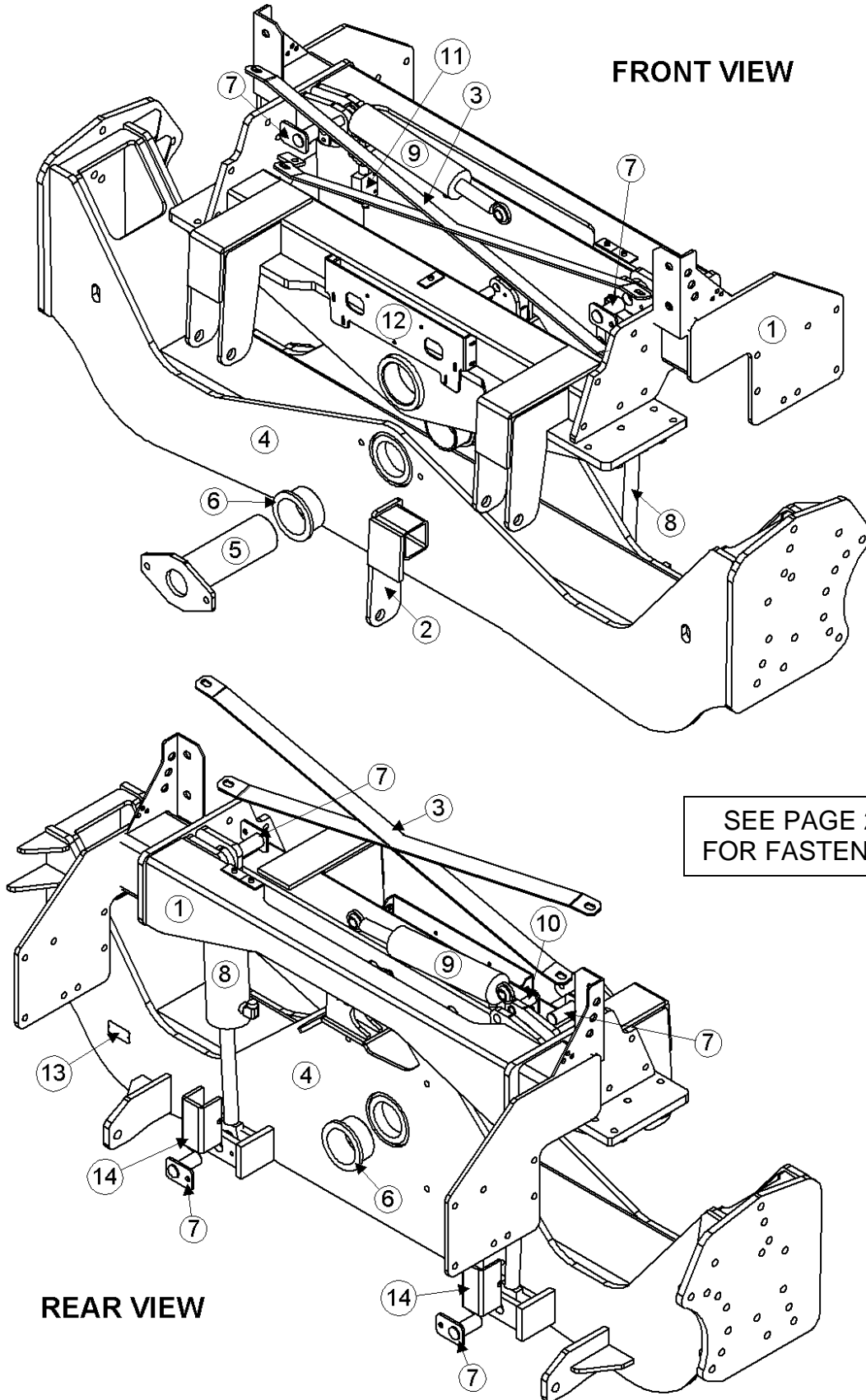

Model 2800 Hillco Leveling System  
For Serial Numbers 2800-1157 thru 2800-1180

<b>CARRIAGE</b>				
<b>REF.</b>	<b>PART NO.</b>	<b>QTY.</b>	<b>PART NAME</b>	<b>DESCRIPTION</b>
1	LA-227243	1	CO ASM, TWO CYLINDER	
NS	LA-227253	1	CO ASM, THREE CYLINDER	
2	LA-241131	1	CO ASM, 3RD HEADER LIFT	FOR COMBINES ADDING 3RD HEADER LIFT CYLINDER
3	LM-226631	2	CO STRAP, X BRACE	
4	LA-227263	1	CU UNDERCARRIAGE ASM	
5	LA-217692	1	CM PIN ASM, MAIN PIVOT	
6	LP-103871	2	CO BUSHING, PIVOT	
7	LA-230551	4	CM PIN ASM, MAIN CYLINDER	
8	HC-103227	2	CYLINDER, MAIN	SEE HYDRAULIC PAGE 8-2
NS	HC-134251	2	SEAL KIT, MAIN CYLINDER	
9	HC-101842	1	CYLINDER, MASTER	SEE HYDRAULIC PAGE 8-2
NS	HC-134201	1	SEAL KIT, MASTER CYLINDER	
10	LA-229071	2	TM PIN ASM, TRIM CYLINDER	
11	HC-138901	2	VALVE, 3-PORT COUNTERBALANCE	SEE HYDRAULIC PAGE 8-2
12	LP-249182	1	EM PLATE, ELECTRICAL MOUNT	
13	LA-255941	1	TAG, SERIAL NUMBER	
14	LP-249321	2	CM SPACER, SHIPPING	
<b>OPTIONAL -- CARRIAGE COMPONENTS</b>				
NS	MC-137251	2	COLLAR, 2-PIECE CLAMPING	SAFETY STOP -- QTY. AS NEEDED
NS	MC-137501	?	WASHER, QUICK REPAIR 2"	SAFETY STOP -- QTY. AS NEEDED
<b>MISCELLANEOUS CARRIAGE COMPONENTS</b>				
NS	HC-139481	1	BEHRINGER TWIN CLAMP .620 DIAMETER	HOSES TO TRIM VALVE
NS	HC-139501	1	BEHRINGER TWIN COVER PLT (FOR .620)	HOSES TO TRIM VALVE
NS	HC-139511	1	BEHRINGER TWIN BOLT (FOR .620)	HOSES TO TRIM VALVE
NS	HC-139431	3	BEHRINGER TWIN CLAMP .750 DIAMETER	HOSES BETWEEN CYLINDERS AND HOSES TO LEVELING VALVE
NS	HC-139451	2	BEHRINGER TWIN COVER PLATE (FOR .750)	HOSES BETWEEN CYLINDERS AND HOSES TO LEVELING VALVE
NS	HC-139461	2	BEHRINGER TWIN BOLT (FOR .750)	HOSES BETWEEN CYLINDERS AND HOSES TO LEVELING VALVE
NS	HC-139471	1	BEHRINGER STACK BOLT (FOR .750)	HOSES BETWEEN CYLINDERS AND HOSES TO LEVELING VALVE
NS	HC-133112	1	ABRASION SLEEVE, NYLON -- 2.19 ID X 44 IN	MANIFOLD TO MASTER AND LEVELING CYLINDERS
NS	HC-133541	4	ABRASION SLEEVE, NYLON -- 2.19 ID X 32 IN	3- HYDRO HOSES 1- REAR STEERING
NS	HC-142151	1	ABRASION SLEEVE, NYLON -- 1.66 ID X 12 IN	CASE DRAIN HOSE BY CODE 62 COUPLER BY HYDRO PUMP

Model 2800 Hillco Leveling System  
For Serial Numbers 2800-1157 thru 2800-1180

### CARRIAGE FASTENERS

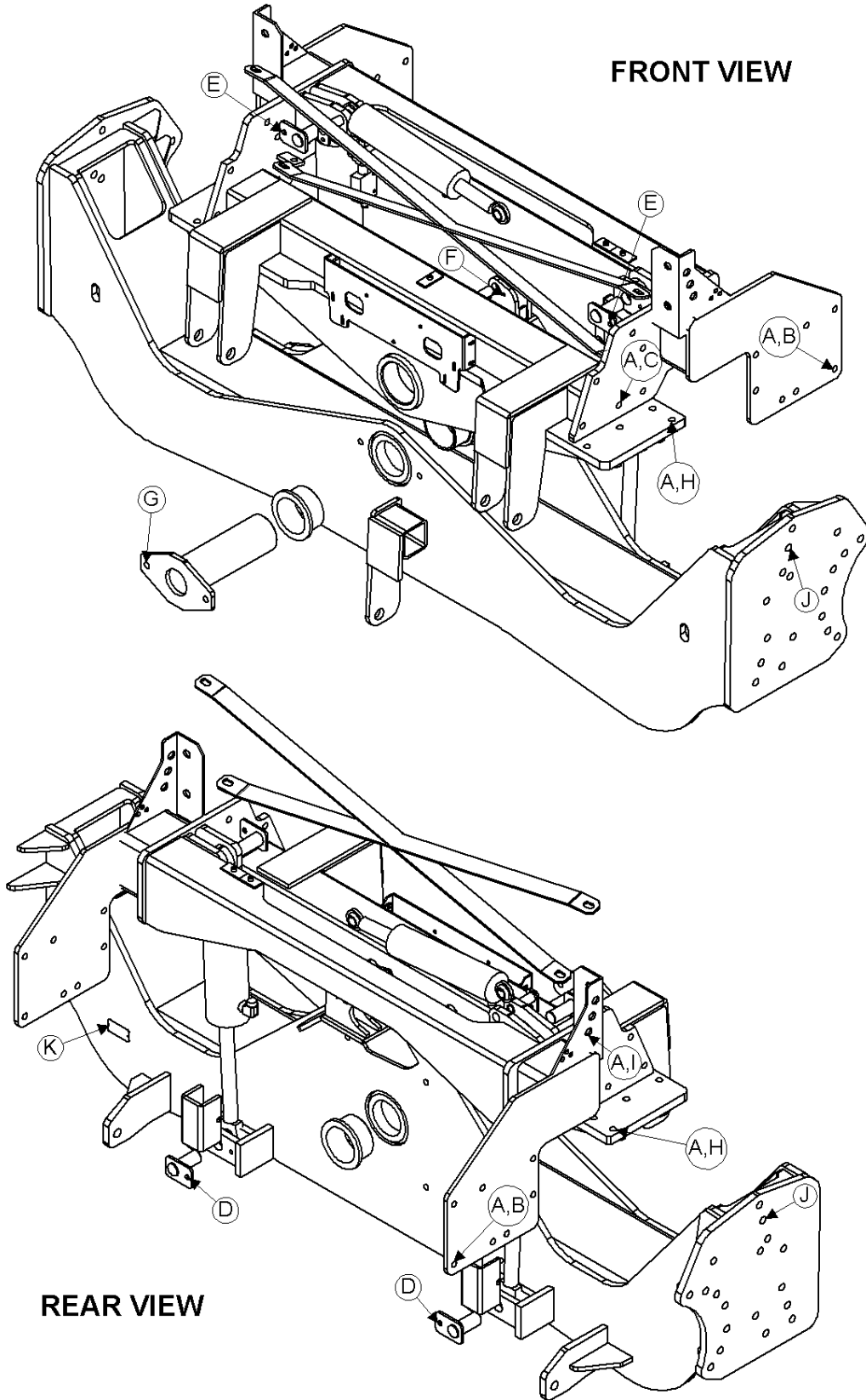

Model 2800 Hillco Leveling System  
For Serial Numbers 2800-1157 thru 2800-1180

<b>CARRIAGE FASTENERS</b>				
<b>REF.</b>	<b>PART NO.</b>	<b>QTY.</b>	<b>PART NAME</b>	<b>WHERE USED</b>
A	F-HNS-10C	34	HN8 5/8-11 STV	OVERCARRIAGE
A	F-FWH-10	44	FW HD 5/8	OVERCARRIAGE
B	F-HC8-10C24	14	HC8 5/8-11 X 1-1/2	OVERCARRIAGE REAR SIDE PLT
C	F-HC8-10C32	12	HC8 5/8-11 X 2	OVERCARRIAGE FRONT SIDE PLT
D	F-HC5-08C16	2	HC5 1/2-13 X 1	LOWER MAIN CYL MNT PIN
D	F-LW-08	2	LW 1/2	LOWER MAIN CYL MNT PIN
E	F-HC5-08C16	2	HC5 1/2-13 X 1	TOP MAIN CYL MNT PIN
E	F-LW-08	2	LW 1/2	TOP MAIN CYL MNT PIN
F	F-HC5-06C14	2	HC5 3/8-16 X 7/8	MASTER CYL MNT PIN
F	F-LW-06	2	LW 3/8	MASTER CYL MNT PIN
G	F-HNS-10C	2	HN8 5/8-11, STV	MAIN PVT PIN
H	F-HC8-10C36	8	HC8 5/8-11 X 2-1/4	OVERCARRIAGE BASE PLT
I	F-HC8-10C32	10	HC8 5/8-11 X 2	OVERCARRIAGE UPPER FRAME SUPPORTS
J	F-SHC-20M065E	6	SHCS 10.9-20 X 2.5 X 65	FINAL DRIVE MOUNTING
J	F-HC-20M065E	22	HC 10.9-20 X 2.5 X 65	FINAL DRIVE MOUNTING
J	F-LWH-20M	28	LW 20 HD	FINAL DRIVE MOUNTING
K	F-UDS-#7X06	2	SCREW, U-DRIVE #7 X 3/8	SERIAL NUMBER PLT

Model 2800 Hillco Leveling System  
For Serial Numbers 2800-1157 thru 2800-1180

### 4 Y-BRACE

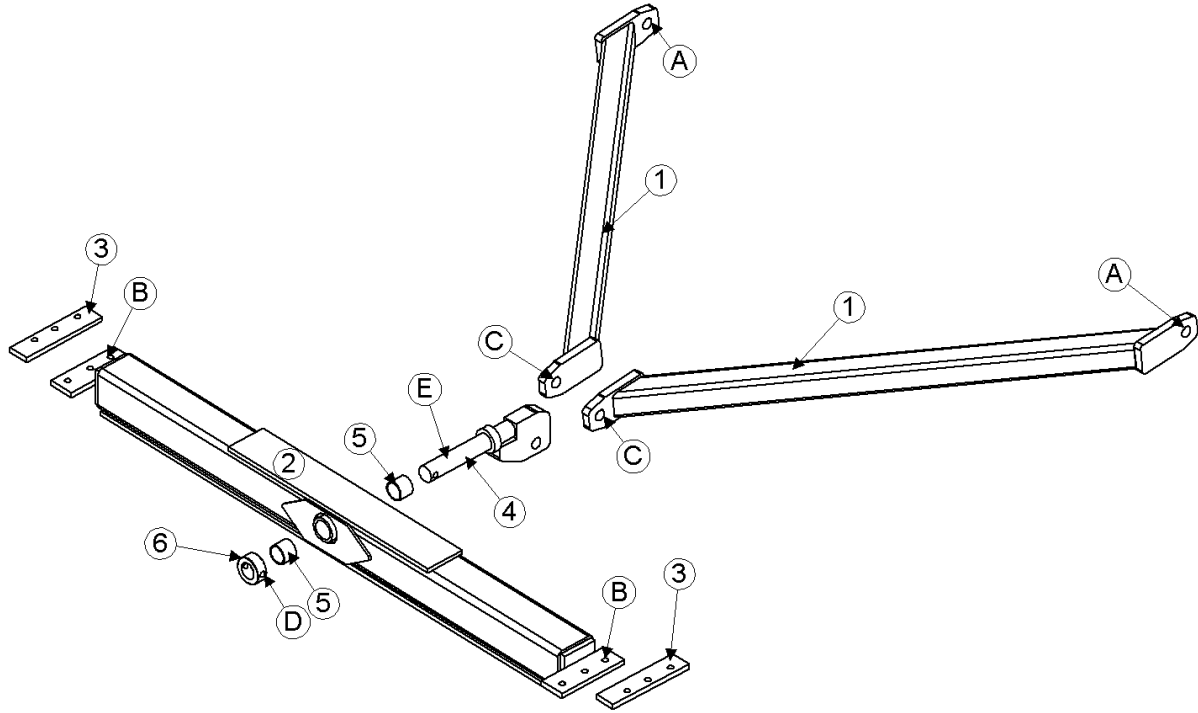



Model 2800 Hillco Leveling System  
For Serial Numbers 2800-1157 thru 2800-1180

<b>Y-BRACE</b>				
<b>REF.</b>	<b>PART NO.</b>	<b>QTY.</b>	<b>PART NAME</b>	<b>DESCRIPTION</b>
1	LA-226991	2	YB ARM ASM	
2	LA-226101	1	YB CROSS SUPPORT ASM	
3	LM-226061	2	YB CLAMP, CROSS SUPPORT	
4	LA-228761	1	YB PIN ASM, PIVOT	
5	LM-245431	2	BUSHING, PLANE	
6	LM-234101	1	YB COLLAR, PIVOT PIN	
<b>Y-BRACE FASTENERS</b>				
<b>REF.</b>	<b>PART NO.</b>	<b>QTY.</b>	<b>PART NAME</b>	<b>WHERE USED</b>
A	F-HC8-16C44	2	HC8 1-8 X 2-3/4	Y-BRACE FRNT MNT
A	F-HNS-16C	2	HN8 1-8, STV	Y-BRACE FRNT MNT
B	F-HC8-08C36	6	HC8 1/2-13 X 2-1/4	Y-BRACE CROSS SUPPORT MNT
B	F-HNS-08C	6	HN8 1/2-13, STV	Y-BRACE CROSS SUPPORT MNT
C	F-HC8-16C72	1	HC8 1-8 X 4-1/2	Y-BRACE REAR MNT
C	F-HNS-16C	1	HN8 1-8, STV	Y-BRACE REAR MNT
D	F-HC8-08C48	1	HC8 1/2-13 X 3	Y-BRACE PVT PIN
D	F-HNS-08C	1	HN8 1/2-13, STV	Y-BRACE PVT PIN
E	F-MB-18NR24	20	BUSHING, MACH 18 GA NR 1-1/2 ID	Y-BRACE PVT PIN

Model 2800 Hillco Leveling System  
For Serial Numbers 2800-1157 thru 2800-1180

### 5 DROP AXLE

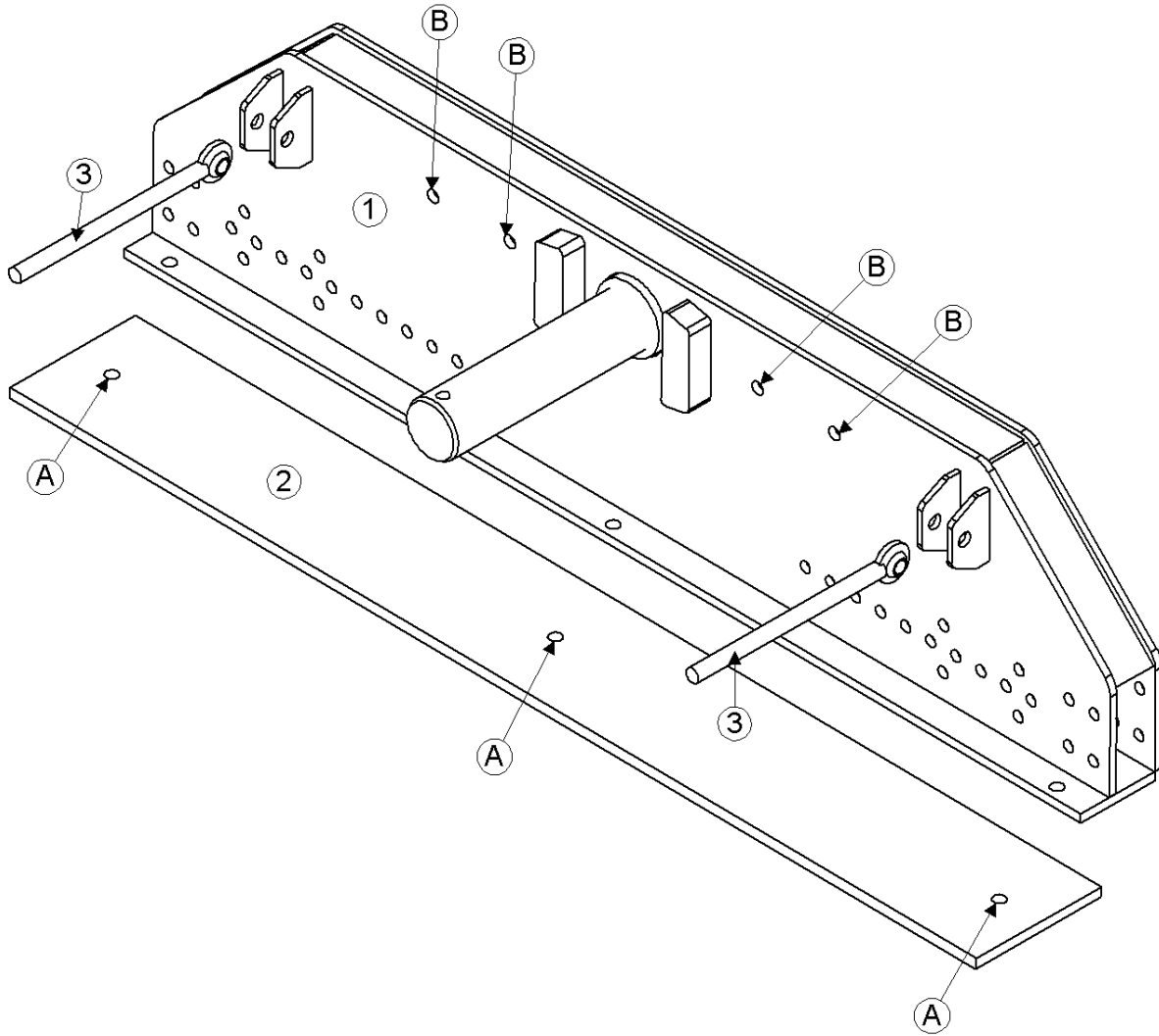

Model 2800 Hillco Leveling System  
For Serial Numbers 2800-1157 thru 2800-1180

<b>DROP AXLE</b>				
<b>REF.</b>	<b>PART NO.</b>	<b>QTY.</b>	<b>PART NAME</b>	<b>DESCRIPTION</b>
1	LA-226901	1	DA ASM	
2	LM-212561	1-10	DA WEIGHT, 160 LB.	1600 LBS. MAX
3	MC-133711	2	LINK, BALL JOINT DRAG	
<b>DROP AXLE FASTENERS</b>				
<b>REF.</b>	<b>PART NO.</b>	<b>QTY.</b>	<b>PART NAME</b>	<b>WHERE USED</b>
NS	F-HC8-12C96	4	HC8 3/4-10 X 6	STEERING CYL MNT
A	F-HC8-12C56	3	HC8 3/4-10 X 3-1/2	1 WEIGHT BOLT PACKAGE
A	F-HC8-12C56	3	HC8 3/4-10 X 3-1/2	2 WEIGHT BOLT PACKAGE
A	F-HC8-12C72	3	HC8 3/4-10 X 4-1/2	3 WEIGHT BOLT PACKAGE
A	F-HC8-12C88	3	HC8 3/4-10 X 5-1/2	4 WEIGHT BOLT PACKAGE
A	F-HC8-12C96	3	HC8 3/4-10 X 6	5 WEIGHT BOLT PACKAGE
A	F-HC8-12C112	3	HC8 3/4-10 X 7	6 WEIGHT BOLT PACKAGE
A	F-HC8-12C120	3	HC8 3/4-10 X 7-1/2	7 WEIGHT BOLT PACKAGE
A	F-HC8-12C136	3	HC8 3/4-10 X 8-1/2	8 WEIGHT BOLT PACKAGE
A	F-HC8-12C144	3	HC8 3/4-10 X 9	9 WEIGHT BOLT PACKAGE
A	F-HC8-12C160	3	HC8 3/4-10 X 10	10 WEIGHT BOLT PACKAGE
A	F-HN8-12C	3	HN8 3/4-10	ALL WEIGHT BOLT PACKAGE
A	F-LW-12A	3	LW 3/4 HD	ALL WEIGHT BOLT PACKAGE
A	F-FWH-12	3	FW 3/4 HD	ALL WEIGHT BOLT PACKAGE
<b>COMBINES WITH 4WD</b>				
B	F-HC5-12C88	4	HC5 3/4-10 X 5-1/2	4WD ASM MNT
B	F-FW-12	4	FW 3/4	4WD ASM MNT
B	F-HNF-12C	4	HN 3/4-10, SERR	4WD ASM MNT
NS	F-HC8-12C96	6	HC8 3/4-10 X 6	STEERING CYLINDER MOUNTS



Model 2800 Hillco Leveling System  
For Serial Numbers 2800-1157 thru 2800-1180

<b>LADDER</b>				
<b>REF.</b>	<b>PART NO.</b>	<b>QTY.</b>	<b>PART NAME</b>	<b>DESCRIPTION</b>
1	LA-248871	1	LM ASM, LEFT LADDER MNT	
2	LA-248881	1	LM ASM, RIGHT LADDER MNT	
3	LA-259751	1	LM ASM, LADDER HANDLE	
4	LA-248851	1	LM STEP ASM, FOLDING LDR	
5	LM-248821	2	LM PLATE, UPPER ARM	
6	LM-248831	2	LM PLATE, FOLDING LADDER LINK	
7	LA-238131	1	LM STEP ASM, REAR SERVICE LDR	
8	MC-139251	2	GAS CHARGED LIFT SUPPORT	
NS	MC-134931	2	LIFT SUPPORT BRACKETS (PAIR)	
9	MC-134941	8	FLANGED BUSHING, OILITE, 1/2 ID X 5/8 OD X 5/16	
<b>LADDER FASTENERS</b>				
<b>REF.</b>	<b>PART NO.</b>	<b>QTY.</b>	<b>PART NAME</b>	<b>WHERE USED</b>
A	F-HC5-08C32	2	HC5 1/2-13 X 2	TOP SIDE PLATE PIVOT
A	F-HNS-08C	2	HN 1/2-13 STV	TOP SIDE PLATE PIVOT
B	F-HC5-08C20	4	HC5 1/2-13 X 1-1/4	MIDDLE PIVOTS
B	F-HNS-08C	4	HN 1/2-13 STV	MIDDLE PIVOTS
C	F-HC5-08C48	2	HC5 1/2-13 X 3	BOTTOM SIDE PLT PIVOTS
C	F-HNS-08C	2	HN 1/2-13 STV	BOTTOM SIDE PLT PIVOTS
D	F-HC5-06C20	6	HC5 3/8-16 X 1-1/4	SIDE PLATE MOUNTS
D	F-HNF-06C	6	FLHN 3/8-16, SERR	SIDE PLATE MOUNTS
E	F-LW-05	4	LW 5/16	BALL STUD
F	F-HNJ-05C	2	HN 5/16-18 JAM	BALL STUD
G	F-HC5-05C12	2	HC5 5/16-18 X 3/4	HANDLE
G	F-HNF-05C	2	FLHN 5/16-18, SERR	HANDLE
H	F-PHMS-06C32	2	PHMS 3/8-16 X 2, SLT	RIGHT REAR SERVICE LADDER EXT STEP
H	F-HNF-06C	2	HN 3/8-16, SERR	RIGHT REAR SERVICE LADDER EXT STEP

Model 2800 Hillco Leveling System  
For Serial Numbers 2800-1157 thru 2800-1180

**7 ELECTRICAL**

\*Note: The fasteners with reference number "D" attach from the bottom of the controller to the box for mounting purposes, however they cannot be seen in this view. The leader is pointing to the general area.

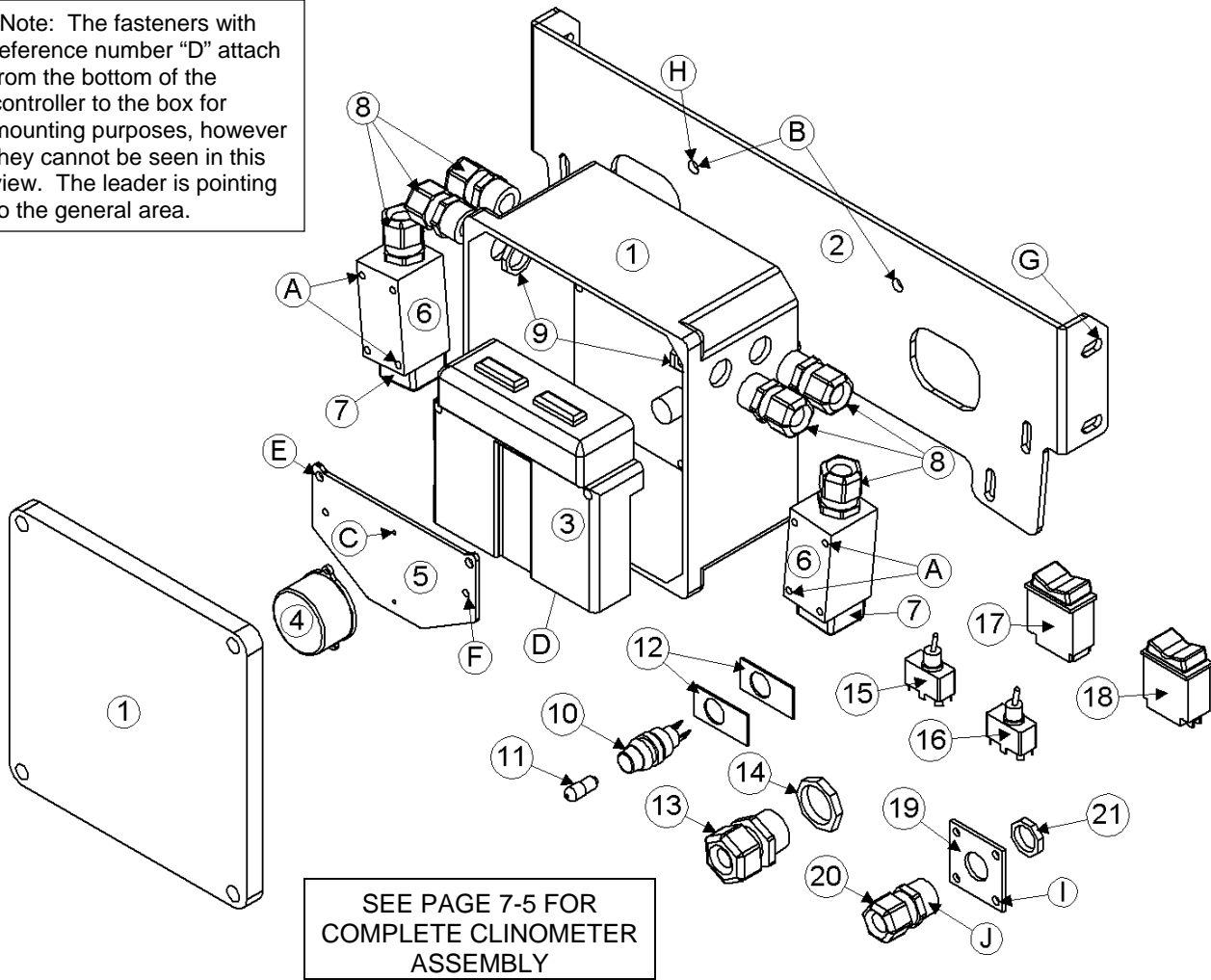

SEE PAGE 7-5 FOR COMPLETE CLINOMETER ASSEMBLY

ELECTRICAL FASTENERS				
REF.	PART NO.	QTY.	PART NAME	WHERE USED
A	F-PHM-#10C28	4	PHMS 10-24 X 1-3/4	LIMIT SWITCH MNT
A	F-HNF-#10C	4	HN 10-24, FLNG SERR	LIMIT SWITCH MNT
B	F-HC5-04C12	3	HC5 1/4-20 X 3/4	PVC BOX TO BRACKET
B	F-LW-04	3	LW 1/4	PVC BOX TO BRACKET
C	F-PHM-#6C06	2	PHMS #6-32 X 3/8	CLINOMETER MOUNT
D	F-PHM-04C24	2	PHMS 1/4-20 X 1-1/2	CONTROLLER TO PVC BOX
D	F-HNF-04C	2	FLHN 1/4-20 SERR.	CONTROLLER TO PVC BOX
E	F-PHM-04C36	2	PHMS 1/4-20 X 2-1/4	GROUNDING PLATE MOUNTING
E	F-HNF-04C	2	FLHN 1/4-20 SERR.	GROUNDING PLATE MOUNTING
F	F-PHM-#10C16	2	PHMS 10-24 X 3/4	GROUNDING PLATE GROUND
F	F-HNF-#10C	2	HN5 10-24, FLNG SERR	GROUNDING PLATE GROUND
F	F-HN-#10C	2	HN5 10-24	GROUNDING PLATE GROUND
G	F-HC5-05C12	4	HC5 5/16-18 X 3/4	EM PLATE ELECTRICAL MNT
G	F-HNF-05C	4	FLHN 5/16-18	EM PLATE ELECTRICAL MNT
H	F-LWE-04	1	LW 1/4, EXTERNAL STAR	MAIN GROUND WIRE
I	F-THC-#10C08	4	THC HWH 10-24 X 1/2	STRAIN RELIEF MOUNT
J	F-MB-18NR18	2	BUSHING, MACH 18 GA, NR, 1-1/8 ID	STRAIN RELIEF ON SIDE OF CAB

Model 2800 Hillco Leveling System  
For Serial Numbers 2800-1157 thru 2800-1180

<b>ELECTRICAL COMPONENTS</b>				
REF.	PART NO.	QTY.	PART NAME	DESCRIPTION
<b>FOR ALL COMBINES</b>				
ASM	LA-249112	1	EM ASM, CONTROLLER	
1	LM-255341	1	EM BOX, CONTROLLER MOUNT	
2	LP-249182	1	EM PLATE, ELECTRICAL MOUNT	
3	EC-141831	1	CONTROLLER	
4	LA-255821	1	EM ASM, CLINOMETER	SEE PAGE 7-5 FOR DETAIL
5	LM-255331	1	EM SHT, CLINOMETER MOUNT	
6	EC-100557	2	BODY, LIMIT SWITCH	
7	EC-100692	2	HEAD, LIMIT SWITCH STRAIGHT PLUNGER	
8	EC-138781	6	STRAIN RELIEF, NYLON, BLK, 1/2 NPT	
9	EC-142121	4	STRAIN RELIEF NUT, 1/2" NYLON, BLK	
10	EC-101876	1	LAMP, INDICATOR	IN CAB CONSOLE
11	EC-101877	1	BULB, INDICATOR LAMP	IN CAB CONSOLE
12	LM-219501	2	EM MOUNT, OUT OF LEVEL LAMP	IN CAB CONSOLE
NS	LL20-101869	1	PLATE, MAXIMUM LEVEL	IN CAB CONSOLE
13	EC-141891	1	STRAIN RELIEF, NYLON, BLK	RIGHT SIDE OF CAB
14	EC-141901	1	STRAIN RELIEF NUT, NYLON, BLK	RIGHT SIDE OF CAB
<b>FOR COMBINES MANUFACTURED PRIOR TO 2006</b>				
15	EC-101874	1	SWITCH, TOGGLE, DP ON-OFF-ON, 3-POS.	AUTO/OFF/MANUAL SWITCH
16	EC-138731	1	SWITCH, TOGGLE, DP MO-OFF-MO, 3-POS.	LEFT/RIGHT LEVELING SWITCH
NS	LL20-101868	1	PLATE, CONSOLE SWITCH	IN CAB CONSOLE
<b>FOR COMBINES MANUFACTURED IN 2006</b>				
17	EC-143401	1	SWITCH, TOGGLE, DP (ON)-OFF-(ON), 3 POS.	LEFT/RIGHT LEVELING SWITCH
18	EC-143411	1	SWITCH, TOGGLE, SP ON-OFF-ON 3 POS.	AUTO/OFF/MANUAL SWITCH
NS	LA-143381	1	LABEL, LEVELING SWITCH	
NS	LA-143391	1	LABEL, AUTO/OFF/MANUAL SWITCH	
<b>FOR COMBINES WITH FIELD TRACKER</b>				
NS	LA-236731	1	AUTO CENTER DISABLE RELAY KIT	
<b>FOR COMBINES WITH FIELD TRACKER ELECTRONICS, BUT NO VALVE</b>				
NS	EC-138781	1	STRAIN RELIEF, NYLON, BLK, 1/2 NPT	MOUNTED TO TRIM VALVE
<b>FOR COMBINES WITHOUT FIELD TRACKER</b>				
19	LM-207631	1	LM MOUNT, CAB STRAIN RELIEF	
20	EC-138781	1	STRAIN RELIEF, NYLON, BLK, 1/2 NPT	RIGHT SIDE OF CAB
21	EC-142121	1	STRAIN RELIEF NUT, 1/2" NYLON, BLK	RIGHT SIDE OF CAB
NS	EC-138781	1	STRAIN RELIEF, NYLON, BLK, 1/2 NPT	MOUNTED ON TRIM VALVE
NS	LA-235472	1	LATERAL TILT RELAY KIT	
NS	EC-100009	2	BASE, RELAY, AUTOMOTIVE	
NS	EC-100010	2	RELAY, AUTOMOTIVE	

Model 2800 Hillco Leveling System  
For Serial Numbers 2800-1157 thru 2800-1180  
**ELECTRICAL CONNECTORS**

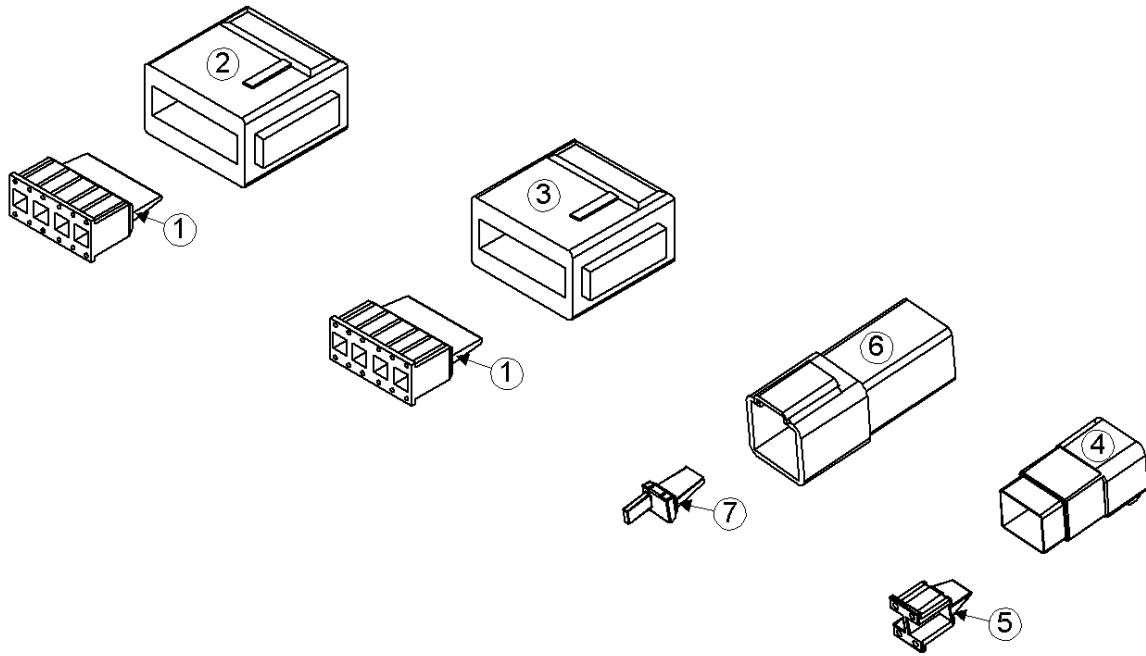



Model 2800 Hillco Leveling System  
For Serial Numbers 2800-1157 thru 2800-1180

<b>ELECTRICAL CONNECTORS</b>				
<b>REF.</b>	<b>PART NO.</b>	<b>QTY.</b>	<b>PART NAME</b>	<b>DESCRIPTION</b>
NS	EC-100008	8	TERMINAL, RELAY, AUTOMOTIVE	
NS	EC-100164	2	PIN, ELECTRICAL	
NS	EC-100165	2	SOCKET, SIZE 16 DEUTSCH	
NS	EC-100693	2	NUT, DRESS, 13/32-32	
NS	EC-139301	4	SPADE, FIFO FEMALE .187	
NS	EC-139311	1	SPADE, FIFO FEMALE .250	
NS	EC-139321	1	SPADE, MALE .187, NON-INSUL, 14-16 GA	
NS	EC-139331	1	RELAY, BOSCH	
1	EC-141741	2	DTM SERIES, 12-SOCKET WEDGE	
2	EC-141751	1	DTM SERIES, 12-SOCKET PLUG - GRAY	
3	EC-141761	1	DTM SERIES, 12-SOCKET PLUG - BLACK	
NS	EC-141771	30	DTM SERIES, SOCKET CONTACT, STAMPED	
NS	EC-141781	4	DTM SERIES, PIN CONTACT, STAMPED	
4	EC-141791	3	DTM SERIES, 4-SOCKET PLUG	
5	EC-141801	3	DTM SERIES, 4-SOCKET WEDGE	
6	EC-141811	1	DTM SERIES, 4-PIN RECEPTACLE	
7	EC-141821	1	DTM SERIES, 4-PIN WEDGE	
NS	ET-QC-20	3	QUICK-CONNECT, BLUE	
NS	ET-SP-16	7	TERMINAL, FEMALE SPADE, NON-INSUL, 16 GA	
NS	ET-SP-20	4	TERMINAL, FEMALE SPADE, NON-INSUL, 20 GA	
NS	ET-ST-20#10	11	TERMINAL, RING, NON-INSUL, #10, 20 GA	
NS	ET-ST-20#6	25	TERMINAL, RING, NON-INSUL, #6, 20 GA	
NS	ET-ST-2004	2	TERMINAL, RING, NON-INS, 1/4, 20 GA	

**ELECTRICAL CABLES**



**#1** LA-249062  
EM CABLE ASM, LEVELING VALVE



**#5** LA-249052  
EM CABLE ASM, FT JUMPER



**#2** LA-255631  
EM CABLE ASM, LIMIT SWITCH



**#6** LA-49072  
EM CABLE ASM, SWITCH TO VALVE



**#3** LA-249102  
EM CABLE ASM, BOX TO VALVE



**#7** LA-249092  
EM ALL CABLE ASM, CAB TO BOX



**#4** LA-255821  
EM CABLE ASM, CLINOMETER



**#8** LA-261721  
EM CABLE ASM, CAB TO BOX

Model 2800 Hillco Leveling System  
 For Serial Numbers 2800-1157 thru 2800-1180

<b>CABLE ASSEMBLIES</b>			
<b>REF.</b>	<b>PART NO.</b>	<b>QTY.</b>	<b>PART NAME AND DESCRIPTION</b>
<b>FOR ALL COMBINES</b>			
1	LA-249062	1	EM CABLE ASM, LEVELING VALVE
2	LA-255631	2	EM CABLE ASM, LIMIT SWITCH
3	LA-249102	1	EM CABLE ASM, BOX TO VALVE
4	LA-255821	1	EM ASM, CLINOMETER
<b>FOR COMBINES WITH FIELD TRACKER ELECTRONICS</b>			
NS	LA-236731	1	RELAY KIT, AUTO CENTER DISABLE
<b>FOR COMBINES WITH FIELD TRACKER ELECTRONICS BUT NO VALVE</b>			
5	LA-249052	1	EM CABLE ASM, FT JUMPER
<b>FOR COMBINES WITHOUT FIELD TRACKER ELECTRONICS</b>			
6	LA-249072	1	EM CABLE ASM, SWITCH TO VALVE
NS	LA-235472	1	RELAY KIT, LATERAL TILT
..	F-PHM-#10C08	2	PHMS 10-24 x 1/2
..	F-HNF-#10C	2	HN 10-24, FLNG., SERR.
<b>FOR COMBINES MANUFACTURED PRIOR TO 2006</b>			
7	LA-249092	1	EM CABLE ASM, CAB TO BOX
<b>FOR COMBINES MANUFACTURED IN 2006</b>			
8	LA-261721	1	EM CABLE ASM, CAB TO BOX

### 8 HYDRAULICS

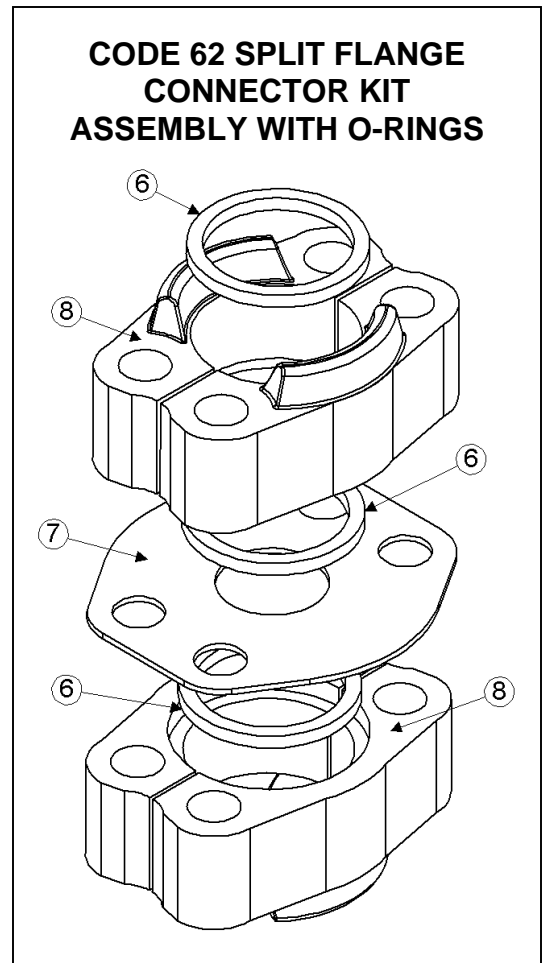
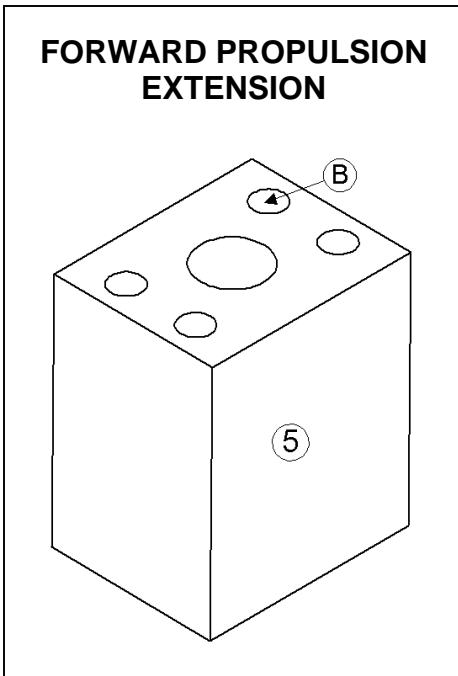
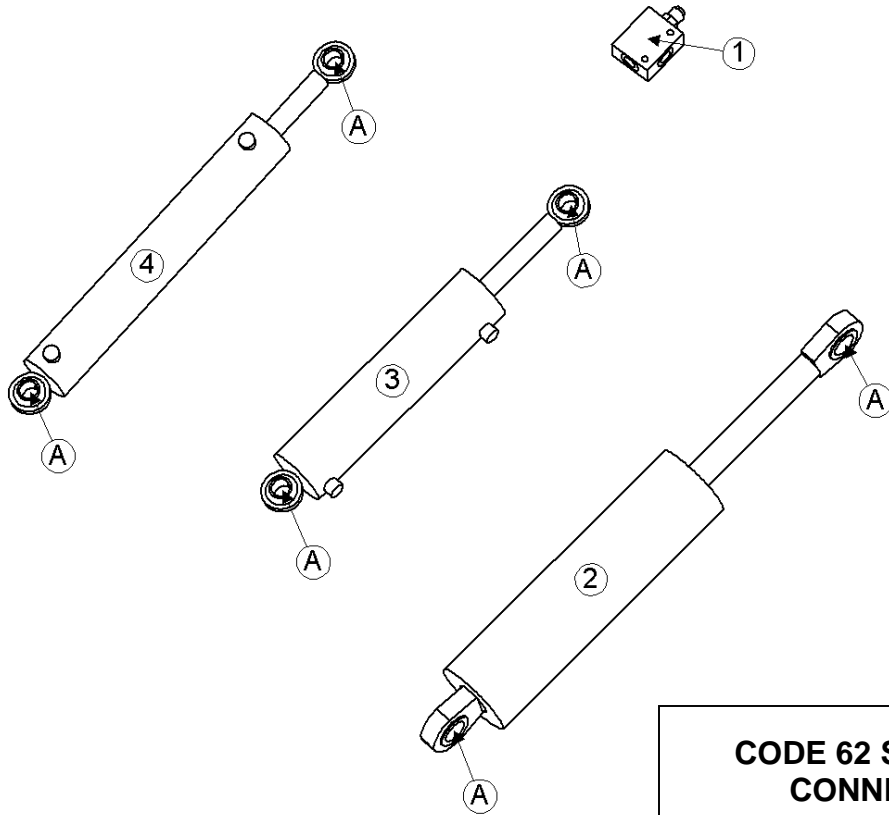

Model 2800 Hillco Leveling System  
For Serial Numbers 2800-1157 thru 2800-1180

<b>COUNTERBALANCE VALVE AND CYLINDERS</b>				
<b>REF.</b>	<b>PART NO.</b>	<b>QTY.</b>	<b>PART NAME</b>	<b>DESCRIPTION</b>
1	HC-138901	2	VALVE, 3-PORT COUNTERBALANCE	
..	HC-139171	2	BODY, COUNTERBALANCE VALVE	
..	HC-139161	2	CARTRIDGE, COUNTERBALANCE VALVE	
NS	HC-140361	2	SEAL KIT, COUNTERBALANCE VALVE	
2	HC-103227	2	CYLINDER, MAIN	
NS	HC-134251	2	SEAL KIT, MAIN CYLINDER	
3	HC-101842	1	CYLINDER, MASTER	
NS	HC-134201	1	SEAL KIT, MASTER CYLINDER	
4	HC-100706	1	CYLINDER, SLAVE	
NS	HC-134191	1	SEAL KIT, SLAVE CYLINDER	
5	HC-140011	1	HM EXTENSION, FORWARD PROPULSION	
<b>CODE 62 SPLIT FLANGE CONNECTOR KIT ASSEMBLY</b>				
ASM	HC-101843	2	CODE 62 SLT FLNG CONNECTOR KIT WITH O-RINGS	FWD AND REVERSE PROPULSION HOSE
6	HC-134911	6	O-RING, CODE 62 CONNECTOR	
7	HC-137891	2	PLATE, CODE 62	
8	HC-137901	4	CODE 62, #16 SPLIT FLANGE KIT	
NS	F-HC8-07C44	8	HC8 7/16 X 2-3/4	
NS	F-HN8-07C	8	HN8 7/16-14	
NS	F-LW-07	4	LW 7/16	
<b>HYDRAULIC FASTENERS</b>				
<b>REF.</b>	<b>PART NO.</b>	<b>QTY.</b>	<b>PART NAME</b>	<b>WHERE USED</b>
A	F-SSS-04F04	8	SET SCREW, SOCKET 1/4-28 X 1/4, GRADE 8	ALL CYLINDERS
B	F-HC8-07C88	4	HC8 7/16-14 X 5-1/2	HYDRO FWD PROPULSION EXTENSION
B	F-LWH-07	4	LW 7/16 HD	HYDRO FWD PROPULSION EXTENSION

**HYDRAULIC MANIFOLD**

**MANIFOLD ASSEMBLY FOR  
 COMBINES WITH FIELD  
 TRACKER VALVE**

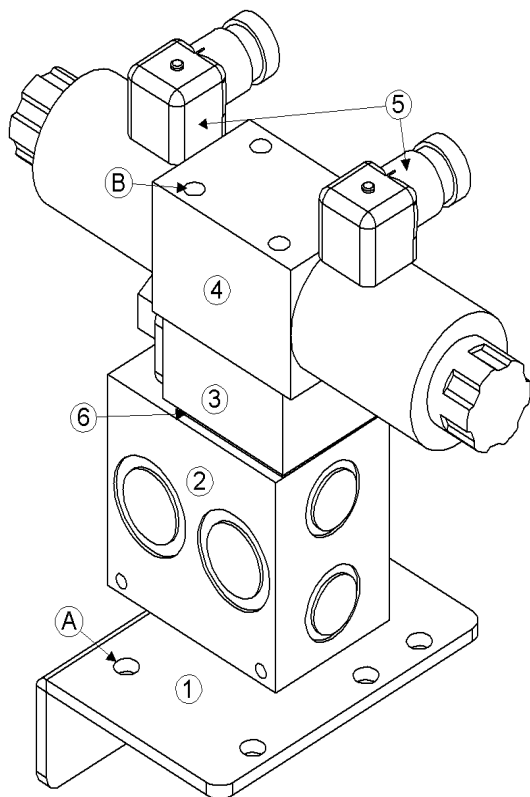

**MANIFOLD ASSEMBLY FOR  
 COMBINES WITHOUT FIELD  
 TRACKER VALVE**

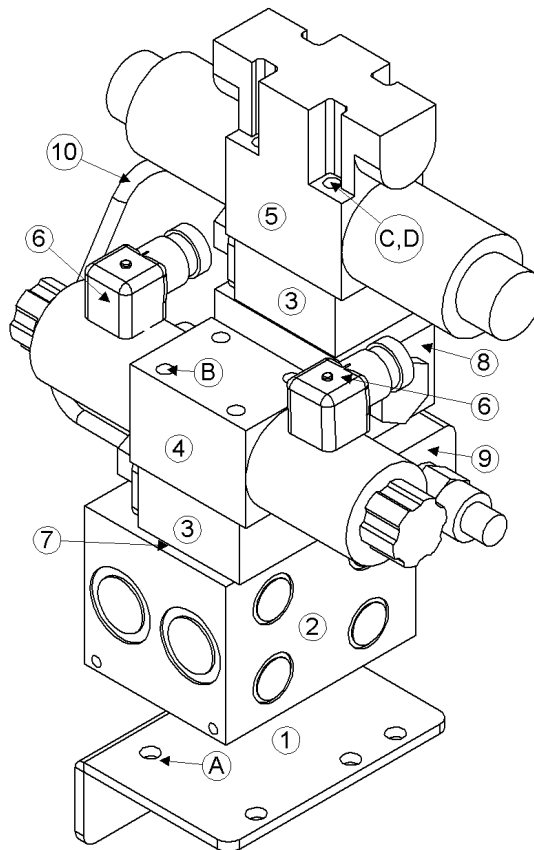

**\*\*Note:** Be sure to look under the correct headings in both the drawings and the lists to the right, as the components for the two manifold assemblies are different.

<b>MANIFOLD FASTENERS</b>				
<b>REF.</b>	<b>PART NO.</b>	<b>QTY.</b>	<b>PART NAME</b>	<b>WHERE USED</b>
<b>FOR ALL COMBINES</b>				
A	F-HNF-05C	4	FLHN 5/16-18 SERR.	SECURES MANIFOLD TO MNT PLT
B	F-SHC-#10C52	4	SHCS 10-24 X 3-1/4	LEVELING SECTION OF MANIFOLD
B	F-LW-#10	4	LW #10	LEVELING SECTION OF MANIFOLD
<b>FOR COMBINES WITHOUT FIELD TRACKER VALVE</b>				
C	LM-249701	4	HM STUD, MANIFOLD TRIM	TRIM SECTION OF MANIFOLD
D	HC-139871	4	NUT, STUD, 10-24	TRIM SECTION OF MANIFOLD

Model 2800 Hillco Leveling System  
For Serial Numbers 2800-1157 thru 2800-1180

<b>MANIFOLD COMPONENTS</b>				
REF.	PART NO.	QTY.	PART NAME	DESCRIPTION
<b>FOR COMBINES WITH FIELD TRACKER VALVE</b>				
1	LM-249041	1	HM PLATE, MANIFOLD MOUNT	
2	HC-138861	1	MANIFOLD, SINGLE STATION	
3	HC-101264	1	SHUTTLE ASM, LOAD SENSE	
..	HC-101021	1	CARTRIDGE, LOAD SENSE VALVE	
..	HC-101022	1	BODY, LOAD SENSE VALVE	
NS	HC-102082	1	SEAL KIT, LOAD SENSE SHUTTLE ASM	
4	HC-140411	1	VALVE, DIRECTIONAL CONTROL, PROPORTIONAL	
NS	LM-250111	1	ORIFICE, .128, "P" PORT ON DIRECTIONAL CONTROL VALVE	
NS	HC-142731	1	SEAL KIT, DIRECTIONAL CONTROL VALVE	
5	HC-140291	2	PLUG, DIN, LIGHTED	
6	HC-142761	1	SUBPLATE	
<b>FOR COMBINES WITHOUT FIELD TRACKER VALVE</b>				
1	LM-249041	1	HM PLATE, MANIFOLD MOUNT	
2	HC-138851	1	MANIFOLD, 2 STATION	
3	HC-101264	2	SHUTTLE ASM, LOAD SENSE	
..	HC-101021	2	CARTRIDGE, LOAD SENSE VALVE	
..	HC-101022	2	BODY, LOAD SENSE VALVE	
NS	HC-102082	2	SEAL KIT, LOAD SENSE SHUTTLE ASM	
4	HC-140411	1	VALVE, DIRECTIONAL CONTROL, LEVELING PROPORTIONAL	
NS	LM-250111	1	ORIFICE, .128, "P" PORT IN DIRECTIONAL CONTROL VALVE	
NS	HC-142731	1	SEAL KIT, DIRECTIONAL CONTROL VALVE	
5	HC-139881	1	VALVE, HEADER TRIM DIRECTIONAL CONTROL	
NS	LM-250121	1	ORIFICE, .55, "P" PORT IN DIRECTIONAL CONTROL VALVE	
NS	HC-142731	1	SEAL KIT, DIRECTIONAL CONTROL VALVE	
6	HC-140291	2	PLUG, DIN, LIGHTED	
7	HC-142761	1	SUBPLATE	
8	HC-138881	1	VALVE, PILOT OPERATED CHECK	
9	HC-138891	1	RELIEF, DUAL	
NS	HC-143951	1	CARTRIDGE, PILOT OPERATED CHECK VALVE	
NS	HC-143961	1	SEAL KIT, PILOT OPERATED CHECK VALVE	
NS	HC-143971	4	O-RINGS, PILOT OPERATED CHECK VALVE	
10	LM-250131	1	HM TUBE, LOAD SENSE	

Model 2800 Hillco Leveling System  
For Serial Numbers 2800-1157 thru 2800-1180

**HYDRAULIC HOSES**

<b>LEVELING MANIFOLD</b>				
<b>REF.</b>	<b>PART NO.</b>	<b>QTY.</b>	<b>PART NAME</b>	<b>WHERE USED</b>
<b>FOR ALL COMBINES</b>				
NS	LA-139571	1	5/8" 100R2 HOSE 47" #10 FORS X #10 FORS 90°	LEVELING VALVE PRESSURE HOSE
NS	LA-140031	1	5/8" 100R2 HOSE 47" #10 FORS 90 X #12 FORS	LEVELING VALVE PRESSURE HOSE
NS	LA-139581	1	5/8" 100R1 HOSE 35" #12 FORS X #10 FORS 90°	LEVELING VALVE RETURN HOSE
NS	LA-140021	1	5/8" 100R2 HOSE 36" #12 FORS X #12 FORS 90°	PRESSURE HOSE TO CASE MANIFOLD
NS	LA-133102	1	1/4" 100R2 HOSE 54" #6 FORS 90 X #4 FORS	LOAD SENSE LINE
<b>LEVELING CIRCUIT</b>				
<b>FOR ALL COMBINES</b>				
NS	LA-139591	1	3/8" 100R2 HOSE 158-1/2" #6 FORS 90 X #6 FORS STR.	LEVELING PORT "A" TO COUNTERBALANCE VALVE PORT #2 RIGHT
NS	LA-139591	1	3/8" 100R2 HOSE 158-1/2" #6 FORS 90 X #6 FORS STR.	LEVELING PORT "B" TO COUNTERBALANCE VALVE PORT #3 RIGHT
NS	LA-139401	1	3/8" 100R2 HOSE 36-3/4" #6 FORS X #6 FORS 90	COUNTERBALANCE VALVE PORT #2 RIGHT TO COUNTERBALANCE VALVE PORT #3 LEFT
NS	LA-139411	1	3/8" 100R2 HOSE 34-1/2" #6 FORS X #6 FORS 90	COUNTERBALANCE VALVE PORT #3 RIGHT TO COUNTERBALANCE VALVE PORT #2 LEFT
NS	LA-139421	2	3/8" 100R2 HOSE 15-1/4" #6 FORS X #6 FORS 90	MAIN ROD TO COUNTERBALANCE VALVE PORT #3 (LEFT & RIGHT)
NS	LA-139401	1	3/8" 100R2 HOSE 36-3/4" #6 FORS X #6 FORS 90	COUNTERBALANCE VALVE PORT #2 LEFT TO COUNTERBALANCE VALVE PORT #3 RIGHT
NS	LA-139411	1	3/8" 100R2 HOSE 34-1/2" #6 FORS X #6 FORS 90	COUNTERBALANCE VALVE PORT #3 LEFT TO COUNTERBALANCE VALVE PORT #2 RIGHT
<b>HEADER TRIM CIRCUIT</b>				
<b>FOR ALL COMBINES</b>				
NS	LA-133423	1	1/4" 100R2 HOSE 111" #6 FORS X #6 FORS	MASTER CYLINDER BASE TO SLAVE CYLINDER BASE
NS	LA-133433	1	1/4" 100R2 HOSE 133" #6 FORS X #6 FORS	MASTER CYLINDER ROD TO SLAVE CYLINDER ROD
<b>FOR COMBINES WITHOUT FIELD TRACKER VALVE</b>				
NS	LA-139601	1	1/4" 100R2 HOSE 145-1/4" #6 FORS STR. BOTH ENDS	TRIM PORT "A" TO MASTER BASE
NS	LA-139611	1	1/4" 100R2 HOSE 135-1/2" #6 FORS STR. BOTH ENDS	TRIM PORT "B" TO MASTER ROD
<b>FOR COMBINES WITH FIELD TRACKER VALVE</b>				
NS	LA-139381	1	1/4" 100R2 HOSE 116-1/4" #6 FORS STR BOTH ENDS	FIELD TRACKER CW PORT TO MASTER BASE
NS	LA-139391	1	1/4" 100R2 HOSE 106-1/2" #6 FORS STR BOTH ENDS	FIELD TRACKER CCW PORT TO MASTER ROD



Model 2800 Hillco Leveling System  
 For Serial Numbers 2800-1157 thru 2800-1180  
**HYDRAULIC HOSES (CONTINUED)**

<b>BRAKE</b>				
REF.	PART NO.	QTY.	PART NAME	WHERE USED
<b>FOR ALL COMBINES</b>				
NS	LA-133471	1	1/4" HTB HOSE (7000 PSI) 56" #4 FORS X #4 FORS	FOOT-N-INCH VALVE (ATTENUATOR)
NS	LA-133481	1	3/8" 100R2 HOSE 39" #6 FORS 90 X #8 FORS	RIGHT BRAKE HOSE
NS	LA-133461	1	3/8" 100R2 HOSE 58" #6 FORS 90 X #6 FORS	LEFT BRAKE HOSE
NS	LA-142141	1	3/8" 100R2 HOSE 36" #6 FORS 90 X #6 FORS 90	REPLACES STEEL BRAKE LINE LOOP ABOVE TRANSMISSION
<b>HYDROSTAT</b>				
<b>FOR ALL COMBINES</b>				
NS	LA-101809	1	1" 6000 PSI WP 18 IN W/1 IN CODE 62 FLANGE ENDS STR.	HYDROSTATIC FORWARD PROPULSION HOSE EXTENSION
<b>FOR SN JJCO047918 THRU JJCO193725</b>				
NS	LA-102097	1	1" 100R15 HOSE 44" W/ 1" CODE 62 FLANGE ENDS	HYDROSTAT FORWARD PROPULSION
NS	LA-102098	1	1" 100R1 HOSE 46" #16 FORS X #16 FORS	CASE DRAIN HOSE
<b>GREASE</b>				
<b>FOR ALL COMBINES</b>				
NS	LA-133322	1	3/16 R1 55 IN GREASE HOSE 1/8 MPT X 1/8 MPT	REMOTE GREASE LINE FROM MASTER ROD
NS	LA-133331	1	3/16 R1 12 IN GREASE HOSE 1/8 MPT X 1/8 MPT	REMOTE GREASE LINE FROM MASTER BASE
NS	LA-133341	1	3/16 R1 9-1/2 IN GREASE HOSE 1/8 MPT X 1/8 MPT	REMOTE GREASE LINE FROM RIGHT LEVELING CYLINDER BASE TO SIDE
NS	LA-133341	1	3/16 R1 9-1/2 IN GREASE HOSE 1/8 MPT X 1/8 MPT	REMOTE GREASE LINE FROM LEFT LEVELING CYLINDER BASE TO SIDE
NS	LA-133351	1	3/16 R1 31-1/2 IN GREASE HOSE 1/8 MPT X 1/8 MPT	REMOTE GREASE LINE FROM MAIN PIVOT PIN TO SIDE

Model 2800 Hillco Leveling System  
For Serial Numbers 2800-1157 thru 2800-1180

**HYDRAULIC ADAPTERS**

<b>LEVELING MANIFOLD</b>				
<b>REF.</b>	<b>PART NO.</b>	<b>QTY.</b>	<b>PART NAME</b>	<b>WHERE USED</b>
<b>FOR ALL COMBINES</b>				
NS	HA-M-6FF6MF	1	#6 ORS SWIVEL NUT RUN TEE	LOAD SENSE LINE AT STEERING PRIORITY VALVE
NS	HA-M-10FF10MF	1	#10 ORS SWIVEL NUT RUN TEE	PRESSURE HOSE AT STEERING PRIORITY VALVE
NS	HA-M-12FF12MF	2	#12 ORS SWIVEL NUT RUN TEE	RETURN HOSE AT RETURN BLOCK & PRESSURE HOSE AT PRIORITY VALVE
NS	HA-A-10MO	2	#10 MORB ALLEN HEAD PLUG	"P" & "T" PORTS
NS	HA-L-10MF10MO	2	#10 MORS X #10 MORB 90°	"P" & "T" PORTS
NS	HA-S-6MF8MO	2	#6 MORS X #8 MORB STRAIGHT	"A" & "B" LEVELING PORTS
NS	HA-L-16MF12MO	1	#16 MORS X #12 MORB 90°	CASE DRAIN ON HYDRO MOTOR
<b>FOR COMBINES WITHOUT FIELD TRACKER VALVE</b>				
NS	HA-S-6MF8MO	2	#6 MORS X #8 MORB STRAIGHT	"A" & "B" TRIM PORTS
NS	HA-T-4MF4MO	1	#4 MORB X #4 MORS STRAIGHT THREAD RUN TEE	LOAD SENSE SHUTTLE
NS	HA-S-4MF4MO	1	#4 MORB X #4 MORS STRAIGHT	LOAD SENSE SHUTTLE
NS	HC-139901	2	#4 ORS-TF NUT	STEEL LOAD SENSE LINE
NS	HC-139911	2	#4 ORS-TF FERRULE	STEEL LOAD SENSE LINE
NS	HC-139921	2	#4 ORS-TF SLEEVE	STEEL LOAD SENSE LINE
<b>FOR COMBINES WITH FIELD TRACKER ELECTRONICS BUT NO VALVE</b>				
NS	HA-T-4MF4MO	1	#4 MORB X #4 MORS STRAIGHT THREAD RUN TEE	LOAD SENSE SHUTTLE
NS	HA-S-4MF4MO	1	#4 MORB X #4 MORS STRAIGHT	LOAD SENSE SHUTTLE
NS	HC-139901	2	#4 ORS-TF NUT	STEEL LOAD SENSE LINE
NS	HC-139911	2	#4 ORS-TF FERRULE	STEEL LOAD SENSE LINE
NS	HC-139921	2	#4 ORS-TF SLEEVE	STEEL LOAD SENSE LINE
<b>FOR COMBINES WITH FIELD TRACKER VALVE</b>				
NS	HA-L-4MF4MO	1	#4 MORS X #4 MORB 90°	LOAD SENSE SHUTTLE
NS	HA-L-6MF6MO	2	#6 MORS X #6 MORB 90°	FIELD TRACKER CW AND CCW PORTS
<b>MAIN CYLINDERS AND COUNTERBALANCE VALVE</b>				
NS	HA-Q-6MF6MO	3	#6 MORS X #6 MORB STRAIGHT THREAD BRANCH TEE	LEFT & RIGHT COUNTERBALANCE VALVE PORT #3 AND COUNTERBALANCE #2 RIGHT
NS	HA-K-6MF6FF	1	#6 MORS X #6 FORS SWIVEL NUT BRANCH TEE	RIGHT COUNTERBALANCE VAVLE PORT #3
NS	HA-L-6MF6MO	1	#6 MORS X # 6 MORB 90°	LEFT COUNTERBALANCE VALVE PORT #2
NS	HA-S-6FO8MO	2	#6 FORB X #8 MORB STR	LEFT & RIGHT MAIN CYLINDER BASE
NS	HA-L-6MF8MO	2	#6 MORS X #8 MORB 90°	LEFT & RIGHT MAIN CYLINDER ROD
NS	HA-L-6MO6MO	2	#6 MORB X #6 MORB 90°	LEFT & RIGHT COUNTERBALANCE VALVE PORT #1 TO MAIN CYL BASE
<b>MASTER AND SLAVE CYLINDERS</b>				
NS	HA-Q-6MF6MO	2	#6MORS X #6MORB STRAIGHT THREAD BRANCH TEE	MASTER BASE AND ROD PORTS
NS	HA-L-6MF6MO	2	#6 MORS X #6 MORB 90°	SLAVE BASE AND ROD PORTS

Model 2800 Hillco Leveling System  
 For Serial Numbers 2800-1157 thru 2800-1180  
**HYDRAULIC ADAPTERS (CONTINUED)**

<b>GREASE</b>				
<b>REF.</b>	<b>PART NO.</b>	<b>QTY.</b>	<b>PART NAME</b>	<b>WHERE USED</b>
NS	HC-133891	1	ZERK, GREASE 1/8 MPT STRAIGHT	TRANSITION MAIN PIVOT PIN
NS	HC-135771	1	1/4-28 MALE X 1/8 FPT 90°	MASTER CYLINDER BASE
NS	HC-135761	2	1/4-28 MALE X 1/8 FPT 45°	LEVELING CYLINDERS BASE
NS	HC-138011	5	ZERK, GREASE 1/4-28 STRAIGHT	ALL GREASE HOSES
NS	HA-NJ-2FN	5	1/8 NPSM BULKHEAD LOCKNUT	BULKHEAD CONNECTORS
NS	HA-S-2FP2MN	5	1/8 NPSM X 1/8 FPT BULKHEAD CONNECTOR	BULKHEAD CONNECTORS
NS	HC-135881	1	1/4-28 MALE X 1/8 FPT STR	MASTER CYLINDER ROD
NS	HA-L-2FP2MP	1	1/8 MPT 90 STREET EL	MAIN PIVOT PIN

Model 2800 Hillco Leveling System  
For Serial Numbers 2800-1157 thru 2800-1180

**9 MISCELLANEOUS**

<b>DOCUMENTS AND LABELS</b>				
<b>REF.</b>	<b>PART NO.</b>	<b>QTY.</b>	<b>PART NAME</b>	<b>DESCRIPTION</b>
NS	LA-141951	2	DECAL, CASE HILLSIDE	HILCO TECHNOLOGIES HILLSIDE
NS	LL20-100782	1	CAUTION LEVELING SYSTEM CAB	
NS	LL20-100783	6	DANGER CRUSHING HAZARD	
NS	LL20-100784	2	DANGER PINCH POINT	
NS	LL20-100785	1	CAUTION MOVING STEP	
NS	LL20-100786	1	WARNING ELECTRONIC CRUSHING HAZARD	FRONT OF CONTROL BOX
NS	LL20-100787	2	CAUTION LEVELING SYSTEM HAZARD	
NS	LL20-101868	1	PLATE, CONSOLE SWITCH	
NS	LL20-101869	1	PLATE, MAXIMUM LEVEL	
NS	LL20-100788	3	DANGER HYDRAULIC HAZARD	
NS	LL-133731	1	LABEL, GREASE 10 HRS	REAR AXLE
NS	LL-133731	1	LABEL, GREASE 10 HRS	RH OVERCARRIAGE
NS	LL-133731	1	LABEL, GREASE 10 HRS	LH OVERCARRIAGE
NS	LL-133731	1	LABEL, GREASE 10 HRS	TT PVT PIN
NS	LL-133731	1	LABEL, GREASE 10 HRS	RH TRANS SIDE PLT
NS	LL-133731	1	LABEL, GREASE 10 HRS	HDR LIFT CYL MNT (MAIN PVT PIN)
NS	LL-133731	2	LABEL, GREASE 10 HRS	MAIN LEV CYL BOTTOM (RH & LH)
NS	LL-143381	1	LABEL, LEVELING SWITCH	
NS	LL-143391	1	LABEL, AUTO-OFF-MANUAL SWITCH	
NS	LA-255941	1	TAG, SERIAL NUMBER 2800	<i>SEE PAGE 1-3 FOR PLACEMENT</i>
NS	D-010223DJC01	1	MANUAL, OPERATOR'S	
NS	D-010310DJC08	1	MANUAL, DEALER INSTALLATION	
NS	D-060609ADL01A	1	MANUAL, PARTS	
<b>HOSE CLAMPS AND FASTENERS</b>				
<b>REF.</b>	<b>PART NO.</b>	<b>QTY.</b>	<b>PART NAME</b>	<b>WHERE USED</b>
NS	MC-101342	2	CLAMP R/C 1/4H 1-1/2T	AXLE FRONT CORNER GUSSET
NS	MC-101343	1	CLAMP R/C 1/4H 2-7/16T	LEFT SIDE OVERCARRIAGE
NS	F-HC5-04C12	3	HC5 1/4-20 X 3/4	HOSE CLAMPS
NS	F-HNF-04C	3	HN 1/4-20, FLNG SERR	HOSE CLAMPS
NS	F-FW-04	3	FW 1/4	HOSE CLAMPS
NS	MC-101342	1	CLAMP R/C 1/4H 1-1/2T	TRANSITION RIGHT UP-RIGHT
NS	F-HNF-04C	1	HN 1/4-20, FLNG SERR	HOSE CLAMP NUT
NS	F-HC5-04C16	1	HC5 1/4-20 X 1	HOSE CLAMP BOLT

Model 2800 Hillco Leveling System  
For Serial Numbers 2800-1157 thru 2800-1180

**10 PART NUMBER INDEX**

PART NUMBER	PAGE NUMBER	PART NUMBER	PAGE NUMBER	PART NUMBER	PAGE NUMBER	PART NUMBER	PAGE NUMBER
D-010223DJC01	9-1	F-HC5-08C176	2-4	F-MB-14NR40	2-6	HC-138011	8-8
D-010310DJC08	9-1	F-HC5-08C20	2-6, 6-2	F-MB-18NR18	7-1	HC-138851	8-4
D-060609ADL01A	9-1	F-HC5-08C32	2-6, 6-2	F-MB-18NR24	4-2	HC-138861	8-4
EC-100008	7-4	F-HC5-08C48	6-2	F-PCL-10X24	2-6	HC-138881	8-4
EC-100009	7-2	F-HC5-12C88	5-2	F-PCT-02X16	2-6	HC-138891	8-4
EC-100010	7-2	F-HC8-06C16	2-6	F-PCT-05X48	2-4	HC-138901	3-2, 8-2
EC-100164	7-4	F-HC8-07C44	8-2	F-PHM-#10C08	7-6	HC-139161	8-2
EC-100165	7-4	F-HC8-07C88	8-2	F-PHM-#10C16	7-1	HC-139171	8-2
EC-100557	7-2	F-HC8-08C36	4-2	F-PHM-#10C28	7-1	HC-139431	3-2
EC-100692	7-2	F-HC8-08C44	2-6	F-PHM-#6C06	7-1	HC-139451	3-2
EC-100693	7-4	F-HC8-08C48	4-2	F-PHM-04C24	7-1	HC-139461	3-2
EC-101874	7-2	F-HC8-08F20	2-4	F-PHM-04C36	7-1	HC-139471	3-2
EC-101876	7-2	F-HC8-10C24	3-4	F-PHMS-06C32	6-2	HC-139481	3-2
EC-101877	7-2	F-HC8-10C32	2-6, 3-4	F-SHC-#10C52	8-3	HC-139501	3-2
EC-138731	7-2	F-HC8-10C36	3-4	F-SHC-20M065E	3-4	HC-139511	3-2
EC-138781	7-2	F-HC8-10C80	2-6	F-SSS-04F04	8-2	HC-139871	8-3
EC-139301	7-4	F-HC8-12C112	5-2	F-SSS-06C08	2-4, 2-6	HC-139881	8-4
EC-139311	7-4	F-HC8-12C120	5-2	F-THC-#10C08	7-1	HC-139901	8-7
EC-139321	7-4	F-HC8-12C136	5-2	F-THM-06C16	2-6	HC-139911	8-7
EC-139331	7-4	F-HC8-12C144	5-2	F-THMS-04C08	2-6	HC-139921	8-7
EC-141741	7-4	F-HC8-12C160	5-2	F-THMS-05C16	2-6	HC-140011	8-2
EC-141751	7-4	F-HC8-12C56	5-2	F-UDS-#7X06	3-4	HC-140291	8-4
EC-141761	7-4	F-HC8-12C72	5-2	HA-A-10MO	8-7	HC-140361	8-2
EC-141771	7-4	F-HC8-12C88	5-2	HA-K-6MF6FF	8-7	HC-140411	8-4
EC-141781	7-4	F-HC8-12C96	5-2	HA-L-10MF10MO	8-7	HC-142151	3-2
EC-141791	7-4	F-HC8-16C44	4-2	HA-L-16MF12MO	8-7	HC-142731	8-4
EC-141801	7-4	F-HC8-16C72	4-2	HA-L-2FP2MP	8-8	HC-142761	8-4
EC-141811	7-4	F-HC8-20C40	2-4	HA-L-4MF4MO	8-7	HC-143951	8-4
EC-141821	7-4	F-HN-#10C	7-1	HA-L-6MF6MO	8-7	HC-143961	8-4
EC-141831	7-2	F-HN5-04C	2-6	HA-L-6MF8MO	8-7	HC-143971	8-4
EC-141891	7-2	F-HN5-06C	2-6	HA-L-6MO6MO	8-7	LA-101809	8-6
EC-141901	7-2	F-HN5-08C	2-6	HA-M-10FF10MF	8-7	LA-102097	8-6
EC-142121	7-2	F-HN8-07C	8-2	HA-M-12FF12MF	8-7	LA-102098	8-6
EC-143401	7-2	F-HN8-12C	5-2	HA-M-6FF6MF	8-7	LA-133102	8-5
EC-143411	7-2	F-HNF-#10C	7-1, 7-6	HA-NJ-2FN	8-8	LA-133322	8-6
ET-QC-20	7-4	F-HNF-04C	2-6, 7-1, 9-1	HA-Q-6MF6MO	8-7	LA-133331	8-6
ET-SP-16	7-4	F-HNF-05C	2-6, 6-2, 7-1, 8-3	HA-S-2FP2MN	8-8	LA-133341	8-6
ET-SP-20	7-4	F-HNF-06C	2-6, 6-2	HA-S-4MF4MO	8-7	LA-133351	8-6
ET-ST-20#10	7-4	F-HNF-12C	5-2	HA-S-6FO8MO	8-7	LA-133423	8-5
ET-ST-20#6	7-4	F-HNJ-05C	6-2	HA-S-6MF8MO	8-7	LA-133433	8-5
ET-ST-2004	7-4	F-HNN-10C	2-6	HA-T-4MF4MO	8-7	LA-133461	8-6
F-CB-06C20	2-6	F-HNN-12C	2-6	HC-100706	2-2, 8-2	LA-133471	8-6
F-CB-10C40	2-6	F-HNS-05F	2-2, 2-6	HC-101021	8-4	LA-133481	8-6
F-EB-04C20	2-6	F-HNS-06C	2-6	HC-101022	8-4	LA-139381	8-5
F-FHS-05F10	2-6	F-HNS-08C	2-4, 4-2, 6-2	HC-101264	8-4	LA-139391	8-5
F-FHS-05F20	2-2, 2-6	F-HNS-10C	2-6, 3-4	HC-101842	3-2, 8-2	LA-139401	8-5
F-FW-04	9-1	F-HNS-16C	4-2	HC-101843	8-2	LA-139411	8-5
F-FW-12	5-2	F-HNS-20C	2-4	HC-102082	8-4	LA-139421	8-5
F-FWH-06	2-6	F-HNSF-08C	2-6	HC-103227	3-2, 8-2	LA-139571	8-5
F-FWH-10	2-6, 3-4	F-LW-#10	8-3	HC-133112	3-2	LA-139581	8-5
F-FWH-12	2-6, 5-2	F-LW-04	2-6, 7-1	HC-133541	3-2	LA-139591	8-5
F-HC-20M065E	3-4	F-LW-05	6-2	HC-133891	8-8	LA-139601	8-5
F-HC5-04C12	7-1, 9-1	F-LW-06	2-6, 3-4	HC-134191	2-2, 8-2	LA-139611	8-5
F-HC5-04C16	9-1	F-LW-07	8-2	HC-134201	3-2, 8-2	LA-140021	8-5
F-HC5-04C20	2-6	F-LW-08	2-6, 3-4	HC-134251	3-2, 8-2	LA-140031	8-5
F-HC5-05C12	6-2, 7-1	F-LW-12A	5-2	HC-134911	8-2	LA-141951	9-1
F-HC5-06C12	2-6	F-LWE-04	7-1	HC-135761	8-8	LA-142141	8-6
F-HC5-06C14	3-4	F-LWH-07	8-2	HC-135771	8-8	LA-143381	7-2
F-HC5-06C20	2-6, 6-2	F-LWH-08	2-4	HC-135881	8-8	LA-143391	7-2
F-HC5-08C104	2-4	F-LWH-20M	3-4	HC-137891	8-2	LA-217692	3-2
F-HC5-08C16	3-4	F-MB-12WR18	2-6	HC-137901	8-2	LA-220631	2-4

Model 2800 Hillco Leveling System  
 For Serial Numbers 2800-1157 thru 2800-1180  
**PART NUMBER INDEX (CONTINUED)**

PART NUMBER	PAGE NUMBER		PART NUMBER	PAGE NUMBER		PART NUMBER	PAGE NUMBER
LA-220641	2-4		LL-143391	9-1		LM-250131	8-4
LA-220651	2-4		LL20-100782	9-1		LM-254521	2-2
LA-220661	2-4		LL20-100783	9-1		LM-255331	7-2
LA-225411	2-2		LL20-100784	9-1		LM-255341	7-2
LA-226101	4-2		LL20-100785	9-1		LP-103871	3-2
LA-226852	2-2		LL20-100786	9-1		LP-104791	2-2
LA-226901	5-2		LL20-100787	9-1		LP-213242	2-2
LA-226991	4-2		LL20-100788	9-1		LP-213252	2-2
LA-227101	2-2		LL20-101868	7-2, 9-1		LP-218371	2-2
LA-227243	3-2		LL20-101869	7-2, 9-1		LP-249182	3-2, 7-2
LA-227253	3-2		LM-207631	7-2		LP-249321	3-2
LA-227263	3-2		LM-212561	5-2		LS-207011	2-2
LA-228761	4-2		LM-213202	2-2		LS-212701	2-2
LA-229071	2-2, 3-2		LM-213291	2-2		LS-225321	2-2
LA-230551	3-2		LM-218501	2-4		LS-226961	2-4
LA-234251	2-2		LM-219501	7-2		LS-234221	2-2
LA-235472	7-2, 7-6		LM-221602	2-2		LS-244471	2-2, 2-4
LA-236731	7-2, 7-6		LM-225311	2-2		LS-257951	2-4
LA-238131	6-2		LM-225522	2-2		MC-100237	2-2
LA-240111	2-4		LM-225531	2-2		MC-100548	2-2
LA-240121	2-4		LM-225541	2-2		MC-100760	2-2
LA-241131	3-2		LM-226061	4-2		MC-100762	2-2
LA-243691	2-2		LM-226532	2-2, 2-4		MC-101339	2-2
LA-243711	2-2		LM-226631	3-2		MC-101342	9-1
LA-245191	2-2		LM-226831	2-2		MC-101343	9-1
LA-248851	6-2		LM-226841	2-2		MC-101838	2-2
LA-248871	6-2		LM-234101	4-2		MC-101839	2-2
LA-248881	6-2		LM-234152	2-2		MC-133711	5-2
LA-249052	7-6		LM-235481	2-4		MC-134931	6-2
LA-249062	7-6		LM-238091	2-2		MC-134941	6-2
LA-249072	7-6		LM-243792	2-2		MC-135491	2-2
LA-249092	7-6		LM-243801	2-2		MC-135501	2-2
LA-249102	7-6		LM-243821	2-2		MC-135511	2-2
LA-249112	7-2		LM-243831	2-2		MC-136921	2-2, 2-4
LA-255631	7-6		LM-243841	2-2		MC-137251	3-2
LA-255821	7-2, 7-6		LM-245431	4-2		MC-137441	2-2
LA-255941	3-2, 9-1		LM-248821	6-2		MC-137501	3-2
LA-259751	6-2		LM-248831	6-2		MC-139251	6-2
LA-259781	2-2		LM-249041	8-4		MC-139341	2-2
LA-261721	7-6		LM-249701	8-3, 8-4		MC-139351	2-2
LL-133731	9-1		LM-250111	8-4		MC-139361	2-2
LL-143381	9-1		LM-250121	8-4		MC-139371	2-2